

Panel Study of Income Dynamics

Wave 40
2017

The Panel Study of Income Dynamics
The Institute for Social Research
426 Thompson Street
Ann Arbor, MI 48104

Last updated: 03/23/2017

Table of Contents

| | |
|---|-----|
| Interview Start | 3 |
| Family Listing | 4 |
| Section A: Housing, Utilities, Computer Use | 17 |
| Section BC: Employment | 29 |
| Section F: Expenditures | 54 |
| Section G: Income; OFUM Education | 71 |
| Section W: Wealth and Active Savings | 123 |
| Section P: Pensions | 138 |
| Section H: Health | 155 |
| Section J: Marriages and Children | 184 |
| Section KL: New Head/SP Background; Returning Head/SP Education | 214 |
| Section IMMIG: New Immigrant..... | 238 |
| Section M: Philanthropy | 252 |
| Interview End..... | 256 |
| Address Updates and Payment | 257 |
| Interview Complete | 288 |

Interview Start

[TOC](#)

RECORDEDIW Rule: Whether IW Flagged For Recording

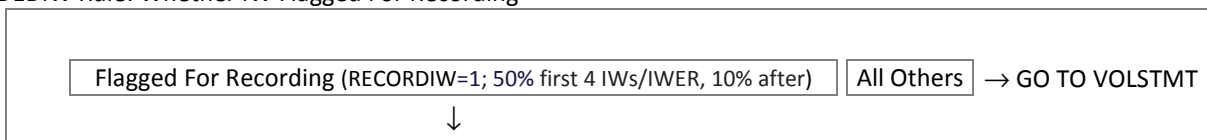

RECORDEDIW_CONSENT. We sometimes record interviews to help us maintain quality. Your interview may be recorded for quality control purposes. Do you agree for this interview to be recorded?

- If R consents to the RECORDING of this interview, ENTER [1]
- If R does not consent to the RECORDING of this interview, ENTER [5]
- If resuming a suspended interview, RE-READ the consent and ENTER [1] if R consents to recording or [5] if R does not consent to recording

1. Yes, consent given 5. No, consent not given

VOLSTMT. **VOLUNTARY STATEMENT: READ to Respondent before the interview begins.**

- [SPANUSED=YES: USE Ctrl-L to switch between English and Spanish at any point during the interview.]

Before I begin, I want you to know that this interview is completely voluntary and confidential. In addition, if we come to any question which you don't want to answer, just let me know and we will go on to the next question. The answers that you give will be kept confidential to the maximum extent allowable under federal and state law.

- ENTER [1] to continue
- If resuming a suspended interview, RE-READ the voluntary statement and ENTER [1] to continue.

1. Continue

Family Listing

[TOC](#)

COVERSCREEN.CYPERSINFO.CYPINFO[1-24] [1-24]=AQS of FU member

AQSN. Sequential ID assigned to each FU member

1 – 24

CYFUHU. *REINT & PRELISTED FU MEMBER*: [In [P2YEAR], we had (you / [CYNAMF CYNAML (CYAQRTH)]) listed as living in this household. (Are you / Is [CYNAMF]) living in this household now? / (In [P2YEAR], we had (you / [CYNAMF]) listed as living in this household.) How about (you / [CYNAMF])? ((Are you/ Is [CYNAMF]) living in this household now?)]

RECON & PRELISTED FU MEMBER: [Next, I'd like to know who lives in this household. (Are you/ Is [CYNAMF CYNAML]) living in this household now? / (Next, I'd like to know who lives in this household.) How about (you / [CYNAMF])? ((Are you / Is [CYNAMF]) living in this household now?)]

- IF NO, change CYFUHU status as follows:
 - 'Mover Out' for a person who moved out to another household;
 - 'Died' if person has died;
 - *Institution* type listed below if person moved to an [institution](#)
- Ctrl-D and Ctrl-R not allowed

1. FU member 6. Mover Out 7. Died 8. Jail 9. Military 10. Education 11. Health 12. Other Inst

Codes 8-12 are for FS=Yes only; FS=No INST are coded Mover Out

REINT, RECON & PRELISTED INST: Is [CYNAMF CYNAML] still [incarcerated / in a military facility / in an educational facility / in a health facility / in an institutional facility]?

SO, RECON-SO, IMMIG16 & PRELISTED FU/FUMI: [Next, I'd like to know who lives in this household. (Are you/ Is [CYNAMF CYNAML]) living in this household now? / (Next, I'd like to know who lives in this household.) How about (you / [CYNAMF])? ((Are you / Is [CYNAMF]) living in this household now?)]

- IF NO, change CYFUHU status as follows:
 - [*PRELISTED INST*: 'FU-Mover In' if person has moved back into the Family Unit;]
 - 'Mover Out' for a person who moved out to another household;
 - 'Died' if person has died;
 - *Institution* type listed below if person moved to an [institution](#)
- Ctrl-D and Ctrl-R not allowed

1. FU member 6. Mover Out 7. Died 8. Jail 9. Military 10. Education 11. Health 12. Other Inst

Codes 8-12 are for FS=Yes only; FS=No INST are coded Mover Out

NEW: [Is anyone else living there now who I did not mention, including any newborn children? / Is anyone else living there (who I did not mention,) (including any newborn children)?]

- IF YES, select and enter CYFUHU status as follows:
 - 'HU Member w/ Own CS' - HU member listed on their own Reinterview CS
 - 'HU Member' - Living in HU, but not a member of this FU
 - 'FU - Mover In' for a new FU Member moved into or born into the Family Unit
- PRESS [Enter] if finished adding family members
- Ctrl-D and Ctrl-R not allowed

2. HU Member w/Own CS 3. HU Member 4. FU Mover In

- CYAQRTH. [CYFUHU=PYFUHU: VERIFY or update 'CYAQRTH' if you have a new Head or change in marital status of Head]
 • [CYFUHU=HUCS, HU, FUMI: ENTER relationship to current Head / CYFUHU=MO, DIED, INST: DO NOT change 'CYAQRTH' if person moved out, died, or moved to some type of institution]
 • Ctrl-D and Ctrl-R not allowed

| | | | | |
|-----------------------------------|------------------|---------------------------------|--------------------|-------------------|
| 101. Male Head | 102. Female Head | 201. Male Spouse | 202. Female Spouse | 221. Male Partner |
| 222. Female Partner | 223 - 882. OFUMs | 901. Uncooperative Male Spouse | | |
| 902. Uncooperative Female Spouse | | 921. Uncooperative Male Partner | | |
| 922. Uncooperative Female Partner | | 951 - 982. OFUMs | | |

- CYNAMF. [CYFUHU=PYFUHU: FOR pre-listed persons, make any name changes indicated by the Respondent / CYFUHU=HUCS, HU, FUMI: FOR newly listed persons, enter and verify spelling of name]
 • Ctrl-D and Ctrl-R not allowed; For DK/RF, type [DK] or [RF]

String 20

- CYNAMM. [CYFUHU=PYFUHU: FOR pre-listed persons, make any name changes indicated by the Respondent / CYFUHU=HUCS, HU, FUMI: FOR newly listed persons, enter and verify spelling of name]

- Ask for Middle Name but do not probe DK or RF
- Ctrl-D and Ctrl-R not allowed; For DK/RF, PRESS [Enter] to continue

String 10

- CYNAML. [CYFUHU=PYFUHU: FOR pre-listed persons, make any name changes indicated by the Respondent / CYFUHU=HUCS, HU, FUMI: FOR newly listed persons, enter and verify spelling of name]

- [LOOPS 2-24: Not necessary to confirm spelling of last name if it's evident that it's the same as a previous family member]
- If needed, include SUFFIX here (e.g. SR, JR)
- Ctrl-D and Ctrl-R not allowed; For DK/RF, type [DK] or [RF]

String 20

GO TO CYFUHU For Next FU Member; Then GO TO FAMLISTCONFIRM

- FAMLISTCONFIRM. Is the Family Listing Table complete?

- SELECT "YES" and continue OR go back to Family Listing Table

1. Yes

END CYPINFO

COVERSCREEN.MOVEIN[1-24] [1-24]=AQS of FU member

MOVEIN Rule: Whether FU Member Moved In Since 1/1/P2YEAR

| | | |
|---|--------------|--|
| Moved-In (REINT/RECON & CYFUHU=FUMI & PYFUHU<>FUMI) | Not Moved-In | → GO TO Next FU Member; Then GO TO MOVER-OUT RULE |
| ↓ | | |

- MOVEINMO. When did [CYNAMF CYNAML] move in?

- SELECT month moved in
- PROBE DK month: Do you know what season it was?

| | | | | | |
|------------|-------------|--------------|-------------|--------------|--------------|
| 1. January | 2. February | 3. March | 4. April | 5. May | 6. June |
| 7. July | 8. August | 9. September | 10. October | 11. November | 12. December |
| 21. Winter | 22. Spring | 23. Summer | 24. Fall | | |

MOVEINYR. (When did [CYNAMF CYNAML] move in?)

- ENTER year moved in
- PROBE /RR/ Move-In years prior to [P2YEAR]

1901 – [CYEAR]

GO TO MOVEIN RULE For Next FU Member; Then GO TO MOVEOUT RULE

END MOVEIN

COVERSCREEN.MOVEOUT[1-24] [1-24]=AQSN of FU member

MOVEOUT Rule: Whether FU Member Moved Out Since 1/1/P2YEAR

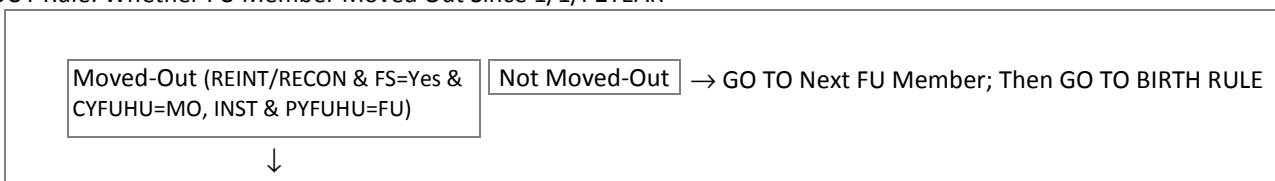

MOVEOUTMO. When did [CYNAMF CYNAML] move out?

- SELECT month moved out
- PROBE DK month: Do you know what season it was?

| | | | | | |
|------------|-------------|--------------|-------------|--------------|--------------|
| 1. January | 2. February | 3. March | 4. April | 5. May | 6. June |
| 7. July | 8. August | 9. September | 10. October | 11. November | 12. December |
| 21. Winter | 22. Spring | 23. Summer | 24. Fall | | |

MOVEOUTYR. (When did [CYNAMF CYNAML] move out?)

- ENTER year moved out
- PROBE /RR/ Move-Out years prior to [P2YEAR]

1901 – [CYEAR]

GO TO MOVEOUT RULE For Next FU Member; Then GO TO BIRTH RULE

END MOVEOUT

COVERSCREEN.CYBIRTHINFO.CYBINFO[1-24] [1-24]=AQSN of FU member

BIRTH Rule: Whether FU Member is Living

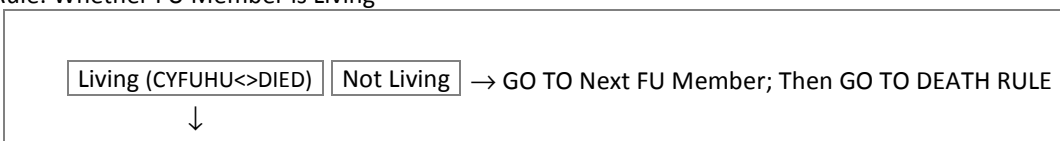

CYMOBRN. Now, I would like to check some birthdate information.

[PRELOADED DOB=RESPONSE: VERIFY: We have (your / [CYNAMF CYNAML]'s) birthdate as [CYMOBRN / CYDYBRN / CYRBRN]. Is that correct? / PRELOADED DOB=NA & CYFUHU=FU, INST: What is (your / [CYNAMF CYNAML]'s) complete birthdate? / PRELOADED DOB=NA & CYFUHU=HUCS, HU, FUMI: And what is (your / [CYNAMF CYNAML]'s) complete birthdate?]

- UPDATE or ENTER month

| | | | | | |
|------------|-------------|--------------|-------------|--------------|--------------|
| 1. January | 2. February | 3. March | 4. April | 5. May | 6. June |
| 7. July | 8. August | 9. September | 10. October | 11. November | 12. December |

CYDYBRN. ([PRELOADED DOB=RESPONSE: VERIFY: We have (your / [CYNAMF CYNAML]'s) birthdate as [CYMOBRN / CYDYBRN / CYRBRN]. Is that correct? / PRELOADED DOB=NA & CYFUHU=FU, INST: What is (your / [CYNAMF CYNAML]'s) complete birthdate? / PRELOADED DOB=NA & CYFUHU=HUCS, HU, FUMI: And what is (your / [CYNAMF CYNAML]'s) complete birthdate?])

- UPDATE or ENTER day

1 – 31

CYRBRN. ([PRELOADED DOB=RESPONSE: VERIFY: We have (your / [CYNAMF CYNAML's]) birthdate as [CYMOBRN / CYDYBRN / CYRBRN]. Is that correct? / PRELOADED DOB=NA & CYFUHU=FU, INST: What is (your / [CYNAMF CYNAML's]) complete birthdate? / PRELOADED DOB=NA & CYFUHU=HUCS, HU, FUMI: And what is (your / [CYNAMF CYNAML's]) complete birthdate?])

- UPDATE or ENTER year

1880 – [CYEAR]

BIRTH2 Rule: Whether Any Part of Birth Date is Non-Response

| | | |
|--------------------------|------------|---|
| CY(MO, DY, YR)BRN=DK, RF | All Others | → GO TO BIRTH RULE For Next FU Member; Then GO TO DEATH RULE |
| ↓ | | |

CYESTAGE. Could you tell me how old (you are/he is/she is)?

- IF necessary: What is your best estimate?

1 – 120 → GO TO DEATH RULE DK/RF

↓

AGEGE16. VERIFY or ASK:

Can you tell me if [CYNAMF CYNAML] is age 16 or older?

1. Yes 5. No DK/RF NOT ALLOWED

GO TO BIRTH RULE For Next FU Member ; Then GO TO DEATH RULE

END CYBINFO

COVERSCREEN.CYDEATHINFO.CYDINFO[1-24] [1-24]=AQS of FU member

DEATH Rule: Whether FU Member Has Died

| | | |
|------------------------|--------------|---|
| Deceased (CYFUHU=DIED) | Not Deceased | → GO TO Next FU Member; Then GO TO MARITAL RULE |
| ↓ | | |

CYMOBRN. [You mentioned that [CYNAMF CYNAML] has died. (We are sorry for your loss.) If I may, I have a few questions about (him/her) at this time. / And you mentioned that [CYNAMF CYNAML] has also died.]

[PRELOADED DOB=RESPONSE: VERIFY: We have [CYNAMF CYNAML's] birthdate as [CYMOBRN / CYDYBRN / CYRBRN]. Is that correct? / PRELOADED DOB=NA: What is [CYNAMF CYNAML's] complete birthdate?]

- UPDATE or ENTER month

| | | | | | |
|------------|-------------|--------------|-------------|--------------|--------------|
| 1. January | 2. February | 3. March | 4. April | 5. May | 6. June |
| 7. July | 8. August | 9. September | 10. October | 11. November | 12. December |

CYDYBRN. ([PRELOADED DOB=RESPONSE: VERIFY: We have [CYNAMF CYNAML's] birthdate as [CYMOBRN / CYDYBRN / CYRBRN]. Is that correct? / PRELOADED DOB=NA: What is [CYNAMF CYNAML's] complete birthdate?])

- UPDATE or ENTER day

1 – 31

CYRBRN. ([PRELOADED DOB=RESPONSE: VERIFY: We have [CYNAMF CYNAML's] birthdate as [CYMOBRN / CYDYBRN / CYRBRN]. Is that correct? / PRELOADED DOB=NA: What is [CYNAMF CYNAML's] complete birthdate?])

- UPDATE or ENTER year

1880 – [CYEAR]

DEATH2 Rule: Whether Any Part of Birth Date is Non-Response

| | | |
|----------------------------|------------|-----------------|
| CY(MO, DY, YR)BRN = DK, RF | All Others | → GO TO BIRTHST |
| ↓ | | |

CYESTAGE. Could you tell me how old (he was/she was)?

- **IF necessary:** What is your best estimate?

1 – 120

BIRTHST. What state was [CYNAMF CYNAML] born in?

- Start typing the name of the State to bring up the look-up list
- If foreign country, ENTER [FOR] to select “Foreign Country” (Note: Specific Country will not be asked)

String 25; State

CYMODTH. And what was (his/her) date of death?

- ENTER month

| | | | | | |
|------------|-------------|--------------|-------------|--------------|--------------|
| 1. January | 2. February | 3. March | 4. April | 5. May | 6. June |
| 7. July | 8. August | 9. September | 10. October | 11. November | 12. December |

CYDYDTH. (And what was (his/her) date of death?)

- ENTER day

1 – 31

CYYRDTH. (And what was (his/her) date of death?)

- ENTER year

1901 – [CYEAR]

DEATHST. What state was [CYNAMF CYNAML] residing in at the time of (his/her) death?

- Start typing the name of the State to bring up the look-up list
- If foreign country, ENTER [FOR] to select “Foreign Country” (Note: Specific Country will not be asked)

String 25; State

END CYDINFO

COVERSCREEN.MARRSTAT.MSTAT[1-24] [1-24]=AQS of FU member

MARITAL Rule: Whether FU Member is 15+ Years Old

| | | |
|--|-----------------------|---|
| 15+ Years Old (AGEIWDATE=15-120 & CYFUHU=FU, FUMI, MO, INST) | Younger than 15 Years | → GO TO Next FU Member; Then GO TO MSCONFIRM |
| ↓ | | |

MARITAL. What is (your/[CYNAMF CYNAML's]) current marital status?

(Are you/[Is he / Is she]) married, widowed, divorced, separated, or (have you/[has he / has she]) never been married?

- If R says Single, **PROBE:** Does that mean (you are/[he is / she is]) widowed, divorced, separated, or (have you/[has he / has she]) never been married?

| | | | | |
|------------|------------------|------------|-------------|--------------|
| 1. Married | 2. Never married | 3. Widowed | 4. Divorced | 5. Separated |
|------------|------------------|------------|-------------|--------------|

↓

GO TO MARITAL RULE For Next FU Member; Then GO TO MSCONFIRM

SPOUNAM. [HEAD/SP LOOP: VERIFY spouse name - Ask R only if you are unclear about the answer: What is (your/[CYNAMF CYNAML]'s) spouse's name? / ALL OTHERS: What is (your/[CYNAMF CYNAML's]) spouse's name?]

String 20

GO TO MARITAL RULE For Next FU Member; Then GO TO MSCONFIRM

MSCONFIRM. Is the Marital Status Information Table complete?

- SELECT "YES" and continue OR go back to Marital Status Information Table

1. Yes

END MSTAT

COVERSCREEN.HUNOTFU[1-24] [1-24]=AQSN of FU member

HUREASON Rule: Whether HU/CS or HU

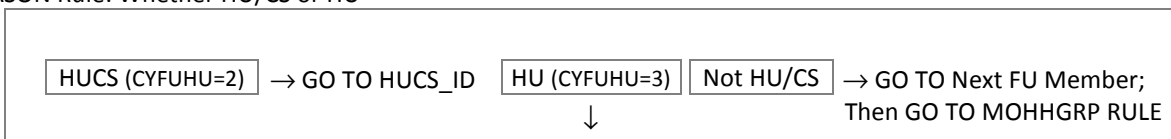

HUREASON. SELECT reason(s) why [CYNAMF CYNAML] is not included in this FU.

- ENTER all that apply

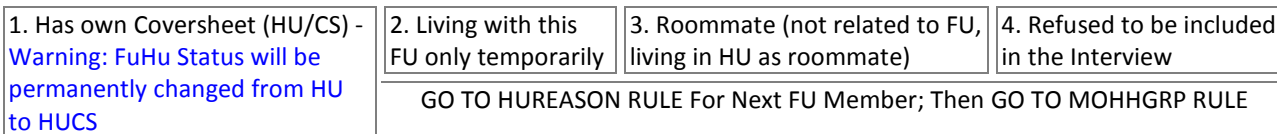

END HUNOTFU

COVERSCREEN.HUCSSAMPID.SIDHUCS[1-24] [1-24]=AQSN of FU member

HUCS_ID. REFER to the Family Listing sheet for this 68ID

- ENTER the Sample IDs of all other FU(s) living in this household

String 7

GO TO HU/CS RULE For Next FU Member; Then GO TO MOHHGRP RULE

END HUNOTFU

MOHHGRP Rule: Whether Any FU Members Moved Out since 1/1/P2YEAR

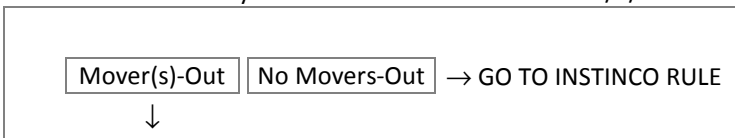

MOHHGRP1. Mover-Out Household Grouping 1

1 MOVER-OUT: Only one person with 'Follow Status = Yes' has moved out of the FU.

- SELECT that person as "MOHHGrp1" and [ENTER] to continue

2 MOVERS-OUT: The following people moved out or are no longer living with (you/the family):

- READ first and last names from answer list below.
- Do these two people now live together in the same household? (Which of these people now live together?)
- IF YES: Select these two people into the first grouping (MOHHGrp1), then [ENTER] to continue
- IF NO: Select each person into their own individual groupings (MOHHGrp1, MOHHGrp2)]

3+ MOVERS-OUT: The following people moved out or are no longer living with (you/the family):

- READ first and last names from answer list below.
- Do any of these [X] people live together in the same household? (Which of these people now live together?)
- IF YES: Select all persons mentioned into the first grouping (MOHHGrp1), then [ENTER] to continue
- IF NO: Select each person into their own individual groupings (MOHHGrp1, MOHHGrp2, etc.)

1 – 24. [CYNAMF CYNAML] [(FS=Yes)] AQSN list of FU Members w/FUHU=MO

MOHHGRP(2-8). Mover-Out Household Grouping [2 - 8]

1 MOVER-OUT LEFT: Only one Mover-Out remains

- SELECT that person as "MOHHGrp[2 - 8]" and [ENTER] to continue

2+ MOVERS-OUT LEFT: Do (any of) the other people who moved out now live together?

- IF NECESSARY: READ first and last names from answer list below.
- IF YES: Select all persons mentioned into "MOHHGrp[2 - 8]", then [ENTER] to continue
- IF NO: Select each person into their own individual groupings (MOHHGrp2, MOHHGrp3, etc.)

1 – 24. [CYNAMF CYNAML] [(FS=Yes)] AQSN list of FU members w/FUHU=MO

MOHHGRP2 Rule: Whether Only One Mover-Out Selected For This MOHHGRP

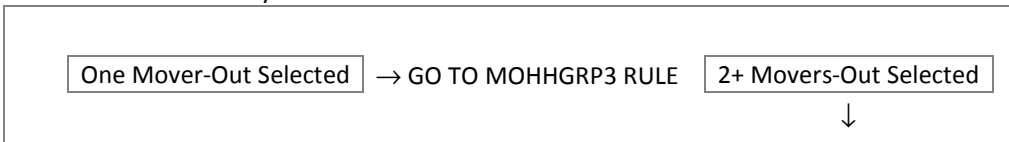

SPLITOFFR(1–8). SELECT one adult as probable Respondent for this household.

- IF there are no adults listed, SELECT oldest child with "FS = YES"

1 – 24. [CYNAMF CYNAML], Age [AGEIWDATE] [(FS=Yes)] AQSN list of FU Members selected at MOHHGRP

MOHHGRP3 Rule: Whether There Are More Movers-Out To Be Assigned To A MOHHGRP



COVERSCREEN.SOCHLIVE[1-8] [1-8]=Which Mover-Out group

SOCHLIVE Rule: Whether Selected Respondent, or Only Sample FU Member in MOHHGRP, is 16+ Years Old

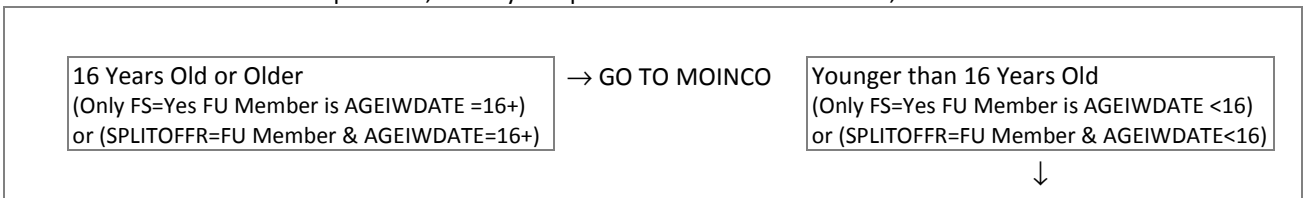

PERSNAMF. Who is [CYNAMF CYNAML] living with now?

String 10

PERSNAML. (Who is [CYNAMF CYNAML] living with now?)

String 15

PERSRTCH. What is (his/her) relationship to [CYNAMF CYNAML]?

String 100

END SOCHLIVE

COVERSCREEN.MOADDRESS[1-8] [1-8]=Which Mover-Out group

MOINCO. Address Update for * Mover Out *

[MO/SPLITOFFR<16 YRS: SplitOff Child, [CYNAMF CYNAML], is living with [PERSNAMF PERSNAML]]

[MO/SPLITOFFR<16 YRS: Can you give me [CYNAMF CYNAML]'s new address, I mean the address of the person with whom (he/she) is now living? Is there an "in care of" for the address? / ALL OTHERS: Can you give me [CYNAMF CYNAML's] new address? Is there an "in care of" for the address?]

- ATTACH comment to any item using [F2]
- If none, PRESS [Enter] to continue
- Ctrl-D and Ctrl-R not allowed; For DK/RF, PRESS [Enter] to continue

String 40

MOADDR1. Address Update for * Mover Out *

[MO/SPLITOFFR<16 YRS: SplitOff Child, [CYNAMF CYNAML], is living with [PERSNAMF PERSNAML]]

What is the street address?

- ATTACH comment to any item using [F2]
- If there is a street address and a PO Box, ENTER PO Box here (ENTER street address in the Address 2 field)
- Ctrl-D and Ctrl-R not allowed; For DK/RF, type [DK] or [RF]

String 40

MOAPTSTE. Address Update for * Mover Out *

[MO/SPLITOFFR<16 YRS: SplitOff Child, [CYNAMF CYNAML], is living with [PERSNAMF PERSNAML]]

(Is there an apartment or suite number?)

- ATTACH comment to any item using [F2]
- If none, PRESS [Enter] to continue
- Ctrl-D and Ctrl-R not allowed; For DK/RF, PRESS [Enter] to continue

String 10

MOADDR2. Address Update for * Mover Out *

[MO/SPLITOFFR<16 YRS: SplitOff Child, [CYNAMF CYNAML], is living with [PERSNAMF PERSNAML]]

(What is the street address?)

- ATTACH comment to any item using [F2]
- If there is a street address and a PO Box, ENTER street address here (ENTER PO Box in Address1 field)
- If none, PRESS [Enter] to continue
- Ctrl-D and Ctrl-R not allowed; For DK/RF, PRESS [Enter] to continue

String 40

MOCITY. Address Update for * Mover Out *

[MO/SPLITOFFR<16 YRS: SplitOff Child, [CYNAMF CYNAML], is living with [PERSNAMF PERSNAML]]

What is the City?

- ATTACH comment to any item using [F2]
- Ctrl-D and Ctrl-R not allowed; For DK/RF, type [DK] or [RF]

String 40

MOSTATE. Address Update for * Mover Out *

[MO/SPLITOFFR<16 YRS: SplitOff Child, [CYNAMF CYNAML], is living with [PERSNAMF PERSNAML]]

What is the State?

- ATTACH comment to any item using [F2]
- Start typing the name of the State to bring up the look-up list
- If foreign country, ENTER [FOR] to select "Foreign Country"

String 20; U.S. State

Foreign Country | DK/RF → GO TO MOPHONE

MOZIP. Address Update for * Mover Out *

[MO/SPLITOFFR<16 YRS: SplitOff Child, [CYNAMF CYNAML], is living with [PERSNAMF PERSNAML]]

What is the Zip code?

- ATTACH comment to any item using [F2]
- If foreign country, ENTER all [0]'s
- Ctrl-D and Ctrl-R not allowed; For DK/RF, ENTER all [0]'s

_____ - _____

MOCOUNTRY. Address Update for * Mover Out *

[MO/SPLITOFFR<16 YRS: SplitOff Child, [CYNAMF CYNAML], is living with [PERSNAMF PERSNAML]]

IF other than USA: What is the Country?

- ATTACH comment to any item using [F2]
- Start typing the name of the Foreign Country to bring up the look-up list

String 30; Country

MOPHONE. Address Update for * Mover Out *

[MO/SPLITOFFR<16 YRS: SplitOff Child, [CYNAMF CYNAML], is living with [PERSNAMF PERSNAML]]

What is the area code and telephone number?

- ATTACH comment to any item using [F2]
- If foreign phone, ENTER all [0]'s and put foreign number in next field
- Ctrl-D and Ctrl-R not allowed; For DK/RF ENTER all [0]'s

(____) _____ - _____

MOPHEXT. Address Update for * Mover Out *

[MO/SPLITOFFR<16 YRS: SplitOff Child, [CYNAMF CYNAML], is living with [PERSNAMF PERSNAML]]

(What is the area code and telephone number) with any extension?

- ATTACH comment to any item using [F2]
- Enter foreign phone number in this field
- If none, PRESS [Enter] to continue
- Ctrl-D and Ctrl-R not allowed; For DK/RF, PRESS [Enter] to continue

String 20

MOPHTYPE. Address Update for * Mover Out *

[MO/SPLITOFFR<16 YRS: SplitOff Child, [CYNAMF CYNAML], is living with [PERSNAMF PERSNAML]]

Is this a home phone, work phone, cell phone, or what?

1. Home phone or residence | 2. Work phone | 3. Cell phone | 4. Pager | 5. Fax | 6. VoIP

7. Other-specify (MOPHTYPESPEC. Specify (String 50))

MOEMAIL Rule: Whether Selected Respondent, or Only Sample FU Member in MOHHGRP, is 16+ Years Old

| | | |
|--|--|-------------------|
| 16 Years Old or Older (Only FS=Yes FU Member is AGEIWDATE =16+) or (SPLITOFFR=FU Member & AGEIWDATE=16+) | Younger than 16 Years Old (Only FS=Yes FU Member is AGEIWDATE <16) or (SPLITOFFR=FU Member & AGEIWDATE<16) | → GO TO DIFFPANFU |
| ↓ | | |

MOEMAIL. Address Update for * Mover Out *

Is there an e-mail address where we can contact [CYNAMF CYNAML]?

1. Yes 5. No → GO TO SOMARSTAT.SOMARST

**MOEMAILADDR. Address Update for * Mover Out ***

(What is that e-mail address?)

- ENTER email address, then READ BACK and VERIFY with Respondent
- Ctrl-D and Ctrl-R not allowed; For DK/RF go back and ENTER [Ctrl-D, Ctrl-R] at previous question

String 50

END MOADDRESS**COVERSCREEN.SOMARSTAT[1-8] [1-8]=Which Mover-Out group**

SOMARST. Is [he / she] married, widowed, divorced, separated, or never married?

1. Married 2. Never married 3. Widowed 4. Divorced 5. Separated DK/RF



GO TOLIVOWNHH

SPOUNAMF. [*MO=HEAD/SP: VERIFY spouse name - Ask R only if you are unclear about the answer:*] What is [CYNAMF CYNAML]'s spouse's name?

String 20

SPOUNAML. [*MO=HEAD/SP: VERIFY spouse name - Ask R only if you are unclear about the answer:*] What is [CYNAMF CYNAML]'s spouse's name?

String 25

LIVOWNHH. Have they set up their own household, have they moved in with another FES (Family Economics Study) family, or have they moved in with a family not in FES?

- BY 'Set up their own household', we mean they are financially independent.
- IF R says "Living with someone else", PROBE: Is that with another FES (Family Economics Study) family, a family not in FES, or have they set up their own household?

| | | | |
|--|---|--|---|
| 1. Yes, set-up own household GO TO SOCHLIVE RULE For Next MOHHGRP; Then GO TO INSTINCO RULE | 2. Moved to a household not in study GO TO PERSNAMF | 3. Moved to an institution (military, education, health, other institution) ↓ | 4. Moved to a household in study GO TO PERSNAMF |
|--|---|--|---|

CHECK FOR LIVOWNHH=3 AND CYFUHU=MOVER-OUT:

You have selected "Moved to an institution" which is not valid for a FU Member who has been coded as Mover-Out in the family listing.

If this FU Member is not a Mover-out, select GOTO to go back to the family listing and enter the correct FU/HU code.

PERSNAMF. Who is [CYNAMF CYNAML] living with now?

String 10

PERSNAML. (Who is [CYNAMF CYNAML] living with now?)

String 15

PERSRTCH. What is (his/her) relationship to [CYNAMF CYNAML]?

String 100

END SOMARSTAT

COVERSCREEN.SOCHOTHFU[1-8] [1-8]=Which Mover-Out group

SIDMOVE Rule: Whether MOHHGRP Moved in with a PSID Family

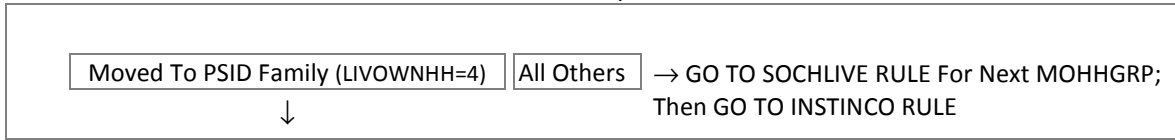

SIDMOVE. ENTER Sample ID of the family unit into which [CYNAMF CYNAML] has moved.

String 7

GO TO SPLITOFF RULE FOR NEXT MOHHGRP; THEN GO TO INST RULE

DIFPANFU. Has SplitOff moved to another household in the Family Economics Panel Study?

- CHECK Family Listing Sheets for this 68ID

| | |
|--------------------------------------|---|
| 1. Yes, moved to another FU in study | 5. No, moved to a household <u>not</u> in the study |
|--------------------------------------|---|

↓

GO TO SOCHLIVE RULE For Next MOHHGRP; Then GO TO INSTINCO RULE

SIDMOVE. ENTER Sample ID of the family unit into which [CYNAMF CYNAML] has moved.

String 7

GO TO SOCHLIVE RULE For Next MOHHGRP; Then GO TO INSTINCO RULE

END SOCHOTHFU**COVERSCREEN.INSTADDRESS[1-24]** [1-24]=AQSN of FU member

INSTINCO Rule: Whether Any FU Member Moved to Institution

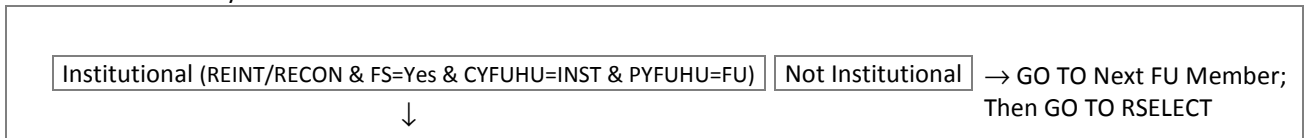

INSTINCO. Address Update for Institutional *[Military / Education / Health / Other]*

Can you give me [CYNAMF CYNAML]'s address and phone number? Is there an "in care of" for the address?

- If none, PRESS [Enter] to continue
- Ctrl-D and Ctrl-R not allowed; For DK/RF, PRESS [Enter] to continue

String 40

INSTADDR1. Address Update for Institutional *[Military / Education / Health / Other]*

(What is the street address?)

- ATTACH comment to any item using [F2]
- If there is a street address and a PO Box, ENTER PO Box here (ENTER street address in the Address 2 field)
- Ctrl-D and Ctrl-R not allowed; For DK/RF, type [DK] or [RF]

String 40

INSTAPTSTE. Address Update for Institutional *[Military / Education / Health / Other]*

(Is there an apartment or suite number?)

- ATTACH comment to any item using [F2]
- If none, PRESS [Enter] to continue
- Ctrl-D and Ctrl-R not allowed; For DK/RF, PRESS [Enter] to continue

String 10

INSTADDR2. Address Update for Institutional *[Military / Education / Health / Other]*

(What is the street address?)

- ATTACH comment to any item using [F2]
- If there is a street address and a PO Box, ENTER street address here (ENTER PO Box in Address1 field)
- If none, PRESS [Enter] to continue
- Ctrl-D and Ctrl-R not allowed; For DK/RF, PRESS [Enter] to continue

String 40

INSTCITY. Address Update for Institutional *[Military / Education / Health / Other]*

What is the City?

- ATTACH comment to any item using [F2]
- Ctrl-D and Ctrl-R not allowed; For DK/RF, type [DK] or [RF]

String 40

INSTSTATE. Address Update for Institutional *[Military / Education / Health / Other]*

What is the State?

- ATTACH comment to any item using [F2]
- Start typing the name of the State to bring up the look-up list
- If foreign country, ENTER [FOR] to select "Foreign Country"

String 20; U.S. State



INSTZIP. Address Update for Institutional *[Military / Education / Health / Other]*
 What is the Zip code?

- ATTACH comment to any item using [F2]
- If foreign country, ENTER all [0]'s
- Ctrl-D and Ctrl-R not allowed; For DK/RF, ENTER all [0]'s

_____-____

Foreign Country DK/RF → GO TO INSTPHONE



INSTCOUNTRY. Address Update for Institutional *[Military / Education / Health / Other]*
 IF other than USA: What is the Country?

- ATTACH comment to any item using [F2]
- Start typing the name of the Foreign Country to bring up the look-up list

String 30; Country

INSTPHONE. Address Update for Institutional *[Military / Education / Health / Other]*

What is the area code and telephone number?

- ATTACH comment to any item using [F2]
- If foreign phone, ENTER all [0]'s and put foreign number in next field
- Ctrl-D and Ctrl-R not allowed; For DK/RF ENTER all [0]'s

(____)____-____

INSTPHEXT. Address Update for Institutional *[Military / Education / Health / Other]*

(What is the area code and telephone number) with any extension?

- ATTACH comment to any item using [F2]
- Enter foreign phone number in this field
- If none, PRESS [Enter] to continue
- Ctrl-D and Ctrl-R not allowed; For DK/RF, PRESS [Enter] to continue

String 20

INSTPHTYPE. Address Update for Institutional *[Military / Education / Health / Other]*

Is this a home phone, work phone, cell phone, or what?

- ATTACH comment to any item using [F2]

1. Home phone or residence 2. Work phone 3. Cell phone 4. Pager 5. Fax 6. VoIP

7. Other-specify (INSTPHTYPESPEC. Specify (String 50))

INSTEMAIL Rule: Whether Institutional Is 16+ Years Old

| | | |
|--|-----------------------|--|
| 16 Years Old or Older (AGEIWDATE=16-120) | Younger than 16 Years | → GO TO INSTINCO RULE For Next FU Member; Then GO TO RSELECT |
| ↓ | | |

INSTEMAIL. [Address Update for Institutional *\[Military / Education / Health / Other\]*](#)

Is there an e-mail address where we can contact [CYNAMF CYNAML]?

1. Yes 5. No → GO TO INST RULE For Next FU Member; Then GO TO RSELECT

↓

INSTEMAILADDR. [Address Update for Institutional *\[Military / Education / Health / Other\]*](#)

(What is that e-mail address?)

- ENTER email address, then READ BACK and VERIFY with Respondent
- Ctrl-D and Ctrl-R not allowed; For DK/RF go back and ENTER [Ctrl-D, Ctrl-R] at previous question

String 50

END INSTADDRESS

RSELECT. [SELECT Respondent from list of FU Members below or enter Code 97 for Proxy Respondent](#)

- NOTE: Proxy Respondent is any person who is not a member of this FU

1 – 24. [CYNAMF CYNAML], [CYAQRTH], [CYFUHU]

AQSN list of FU Members w/FUHU=FU, FUMI and AGE=16+

97. Proxy Respondent-Specify (RSELECTSPEC. Please specify relationship to Head and the Proxy's name (String 100))

FUFINALCONFIRM. [Review the family listing with Respondent.](#) If necessary, go back to make changes. Once past this screen, [you will not be able to go back to the Family Listing](#)

Respondent: [FNAME LNAME]

RTH: [CYAQRTH]

FuHu: [CYFUHU]

1 – 24. [CYNAMF CYNAML], [CYAQRTH], [CYFUHU], [MARITAL], Birthdate: [DOB], Age: [AGEIWDATE]

AQSN list of FU Members w/FUHU=FU, FUMI, INST

- ENTER [1] to confirm family listing and continue

1. Confirm

END COVERSCREEN

Section A: Housing, Utilities, Computer Use

[TOC](#)

SECTION_A

A3CKPT. CAI Checkpoint: Respondent

| | | |
|--|------------------------------------|------------|
| 1. R=Head, Spouse/Partner (RESPONDENT=1, 2, 3) | 5. R=OFUM, Proxy (RESPONDENT=4, 7) | → GO TO A4 |
| ↓ | | |

A3. Please think about your life-as-a-whole. How satisfied are you with it? Are you completely satisfied, very satisfied, somewhat satisfied, not very satisfied, or not at all satisfied?

| | | | | |
|-------------------------|-------------------|-----------------------|-----------------------|-------------------------|
| 1. Completely satisfied | 2. Very satisfied | 3. Somewhat satisfied | 4. Not very satisfied | 5. Not at all satisfied |
|-------------------------|-------------------|-----------------------|-----------------------|-------------------------|

A4. Do you live in a one-family house, a two-family house, an apartment, a mobile home, or what?

- IF R answers "condo," PROBE for the physical structure of the condo: We are looking for the physical structure of your condo. Is it a free standing home, attached to others, or part of a multi-unit building?

| | | |
|---------------------------|-------------------------------|---|
| 1. One-family house | 2. Two-family house or duplex | 3. Apartment in a multi-unit building; project |
| 4. Mobile home or trailer | 6. Row or town house | 7. Other-specify (A4SPEC. Please specify. (String 100)) |

A5CKPT. CAI Checkpoint: Whether Head or Spouse/Partner is Age 55+

| | | |
|--|---------------|------------|
| 1. Head, Spouse/Partner is Age 55+ (AGEIWDAT=55-120) | 5. All Others | → GO TO A8 |
| ↓ | | |

A6A. Some places require at least one family member to be 55 years or older. Is the place you live like that?

| | | |
|--------|-------|------------|
| 1. Yes | 5. No | → GO TO A8 |
|--------|-------|------------|



A7A Rule: Whether FU Lives In Apartment/Project or Other

| | | |
|------------------------------------|------------|------------|
| Apartment/Project, Other (A4=3, 7) | All Others | → GO TO A8 |
| ↓ | | |

A7A. Sometimes places offer services that help with daily activities, such as help with bathing or dressing, group meals, or handling medications. Does the place you live offer services like that?

| | |
|--------|-------|
| 1. Yes | 5. No |
|--------|-------|

A8. For these next questions, when I refer to "family", I mean your family living there with you.

How many rooms do you have [for your family] not counting bathrooms?

- [HU/CS IN FU: Remind R not to include rooms used by HU or HUCS people]
- ENTER [1 -19] for Actual number of rooms;
- ENTER [20] for Twenty or more rooms;
- ENTER [0] if FU shares a one-room HU with non-FU persons

| |
|--------|
| 0 – 20 |
|--------|

A19. Do you [or anyone else in your family living there] own the [A4=APT: apartment / A4=MOBILE: mobile home / ALL OTHERS: home], do you pay rent, or what?

- If R says “coop, cooperative”, PROBE: Are you a shareholder - do you have a purchase agreement - in the cooperative, or do you have a lease agreement?
 - If SHAREHOLDER/PURCHASE agreement or Don't Know, ENTER [1]
 - If LEASE agreement, ENTER [5]

| | | | |
|---|------------------------------|---|-------------------|
| 1. Any FU member owns or is buying (fully or jointly) | 5. FU pays rent GO TO A31 | 8. FU neither owns nor rents GO TO A34 | DK/RF NOT ALLOWED |
|---|------------------------------|---|-------------------|



Owners

A20. Could you tell me what the present value of your [apartment / mobile home / home] is [A4=MOBILE: including the value of the lot if you own the lot] - I mean about how much would it bring if you sold it today?

\$ 0 – 9,999,997 → GO TO A20A1 DK/RF



| | | | |
|---|---|-------------|---------------|
| A20A. Would it amount to \$200,000 or more? | | | |
| 1. Yes | 5. No | DK/RF | → GO TO A20A1 |
| ↓ | ↓ | | |
| A20B. (Would it amount to \$300,000 or more?) | A20D. (Would it amount to \$100,000 or more?) | | |
| 1. Yes 5. No DK/RF | 1. Yes 5. No DK/RF | | |
| ↓ | GO TO A20A1 | GO TO A20A1 | ↓ |
| | | | GO TO A20A1 |
| A20C. (Would it amount to \$500,000 or more?) | A20E. (Would it amount to \$50,000 or more?) | | |
| 1. Yes 5. No DK/RF | 1. Yes 5. No DK/RF | | |

A20A1. If someone were to rent this [apartment/mobile home/home] today, how much do you think it would rent for per month, unfurnished and without utilities?

- ENTER amount here, then SELECT unit of time on next screen (Week, Month, Year)

\$ 1 – 99,997 DK/RF →GO TO A20F RULE



A20A1PER. The rent amount entered is: [A20A1] per ____

- SELECT the unit of time below

3. Week 5. Month 6. Year 7. Other-specify (A20A1PERSPEC. Specify. (String 100))

A20F Rule: Whether FU Lives In Mobile Home

| | | |
|--------------------|------------|-------------|
| Mobile Home (A4=4) | All Others | → GO TO A21 |
|--------------------|------------|-------------|

↓

A20F. Do you rent the lot (where your mobile home is located)?

1. Yes 5. No → GO TO A21



A20G. How much do you pay to rent the lot?

- ENTER amount here, then SELECT unit of time on next screen (Week, Two weeks, Month, Year)

→ GO TO A20H



A20GPER. The amount entered is: [A20G] per ____

- SELECT the unit of time below

A20H. Does [A20G=DK/RF: the lot rent / ALL OTHERS: this amount] include water and sewer?

1. Yes 5. No

A21. About how much are your total yearly property taxes, including city, county, and school taxes?

A22. How much is your total yearly homeowner's insurance premium?

SECTION_A.MGTE[1-2] [1]=1st mortgage, [2]=2nd mortgage

A23. Do you have a mortgage or loan on this property?

→ GO TO A37A



A23A. [1ST MTGE: Is that a mortgage, a land contract, a home equity loan, or what? / 2nd MTGE: For the second mortgage, what type of loan is that?]



GO TO A24

A23B. Is that the original loan and terms, or have you refinanced?

A24. About how much is the remaining principal on this loan?

A25. How much are your monthly loan payments?

A25A1. Does this amount include property taxes?

1. Yes 5. No

A25A2. Does it (this mortgage or loan payment) include insurance premiums?

1. Yes 5. No

A25A3. Is the interest rate on that mortgage or loan fixed or variable?

1. Fixed 2. Variable

A25A4. What is the current interest rate on that loan?

- ENTER the whole number portion and then ENTER the fraction portion at the next screen.

0 – 65 DK/RF → GO TO A26

↓

SIGNAL FOR A25A4 = 25+:

You have entered interest rate = [A25A4] %

- If this is not correct, go back to A25A4 and enter correct amount.
- If this is correct, click [SUPPRESS] to continue.

A25B. (What is the current interest rate on that loan?)

- The whole number amount entered is: [A25A4]. ____ %
- SELECT the fraction portion of the mortgage rate below

| | |
|---|-----------------------------|
| 0. [A25A].0 | 1. [A25A] 1/8 or [A25A].125 |
| 2. [A25A] 1/4 or [A25a].25 | 3. [A25A] 3/8 or [A25A].375 |
| 4. [A25A] 1/2 or [A25A].5 | 5. [A25A] 5/8 or [A25A].625 |
| 6. [A25A] 3/4 or [A25A].75 | 7. [A25A] 7/8 or [A25A].875 |
| 8. Other-specify (A25BSPEC. Please specify. (String 100)) | |

A26. What year did you [A23B=REFINANCED: (last) refinance / ALL OTHERS: obtain that loan?

1901 – [CYEAR]

A27. About how many more years will you have to pay on it?

1 – 97

A27A. [^{1ST} MTGE: Some people have had difficulties recently making their mortgage or loan payments. Are you [or anyone in your family living there], currently behind on your [A23A=MTGE: mortgage / ALL OTHERS: loan] payments? / ^{2ND} MTGE: (Some people have had difficulties recently making their mortgage or loan payments.) Are you [or anyone in your family living there], currently behind on your [A23A=MTGE: mortgage / ALL OTHERS: loan] payments (for this [A23A=MTGE: mortgage / ALL OTHERS: loan])?]

1. Yes 5. No → GO TO A27F

↓

A27B. How many months are you behind?

1 – 97

A27C. Has your bank or lender started the process of foreclosing on your home?

1. Yes 5. No → GO TO A27F

↓

A27D. In what month and year did the foreclosure start?

- SELECT Month and [Enter] to go to next screen for year
- IF NECESSARY: What would be your best estimate?

| | | | |
|--------------|-------------|--------------|--------------|
| 1. January | 2. February | 3. March | 4. April |
| 5. May | 6. June | 7. July | 8. August |
| 9. September | 10. October | 11. November | 12. December |
| 21. Winter | 22. Spring | 23. Summer | 24. Fall |

A27E. (In what month and year did the foreclosure start?)

[A27D], _____

- ENTER Year: [REINT: [P2YEAR] / RECON: [P4YEAR] / ALL OTHERS: 2001] – [CYEAR]

REINTERVIEW [P2YEAR] – [CYEAR]

RECONTACT [P4YEAR] – [CYEAR]

ALL OTHERS 2001 – [CYEAR]

A27F. Have you worked with your bank or lender to restructure or modify your [A23A=MTGE: mortgage / ALL OTHERS: loan] [A27A=YES: because of missed payments]?

1. Yes 5. No

A27G. How likely is it that you [A27A=YES: will continue to be behind / ALL OTHERS: will fall behind] on your [A23A=MTGE: mortgage / ALL OTHERS: loan] payments in the next 12 months? Would you say very likely, somewhat likely, or not likely at all?

1. Very likely 3. Somewhat likely 5. Not likely at all

A28. Do you also have a second mortgage on this property?

1. Yes → Repeat A23A-A27G; MAX=2; 5. No → GO TO A37A
Then GO TO A37A

END MGTE

Renters

A31 Rule: Whether FU Owns, Rents, or Neither Owns Nor Rents

| | | |
|-------------------|------------|------------------|
| Pays Rent (A19=5) | All Others | → GO TO A34 RULE |
| ↓ | | |

A31. About how much rent do you pay a month [A4=MOBILE: , including rent for the lot]?

- [HU/CS IN FU: IF FU lives with non-FU members, PROBE: Is that only for your (FU's) share of the rent?]
- [A4= MOBILE: If FU owns the lot, do not include the value of the lot]
- ENTER amount here, then SELECT unit of time on next screen (Week, Two weeks, Month, Year)

\$ 1 – 99,997 DK/RF → GO TO A31A RULE

↓

A31PER. The rent amount entered is: [A31] per _____

- SELECT the unit of time below

3. Week 4. Two weeks 5. Month 6. Year

7. Other-specify (A31PERSPEC. Specify. (String 100))

A31A Rule: Whether FU Lives In Mobile Home

| | | |
|--------------------|------------|--------------|
| Mobile Home (A4=4) | All Others | → GO TO A31B |
| ↓ | | |

A31A. Does [A31=DK/RF: the rent / ALL OTHERS: this amount] include water and sewer?

| | |
|--------|-------|
| 1. Yes | 5. No |
|--------|-------|

A31B. Is this [apartment / mobile home / home] rented fully furnished?

| | |
|--------|-------|
| 1. Yes | 5. No |
|--------|-------|

A31C. Is heating included in your monthly rent?

| | |
|--------|-------|
| 1. Yes | 5. No |
|--------|-------|

A32. Is this [apartment / mobile home / home] in a public housing project, that is, is it owned by a local housing authority or other public agency?

| | | |
|--------|--------------|-------|
| 1. Yes | → GO TO A37A | 5. No |
|--------|--------------|-------|



A33. Are you paying lower rent because a Federal, State, or local government housing program is paying part of the cost?

(\$[A31] per [A31PER])

- ENTER [5] if R says “does not pay a lower rent”

| | |
|--------|-------|
| 1. Yes | 5. No |
|--------|-------|

Neither Owns nor Rents

A34 Rule: Whether FU Owns, Rents, or Neither Owns Nor Rents

| | | |
|--------------------------------|------------|--------------|
| Neither Owns Nor Rents (A19=8) | All Others | → GO TO A37A |
| ↓ | | |

A34. How is that? (Could you tell me a little more about your situation?)

| |
|------------|
| String 400 |
|------------|

A35. How much would it rent for if it were rented?

- [HU/CS IN FU: IF FU lives with non-FU members, PROBE: Would that be only for your (FU's) share of the rent?]
- ENTER amount here, then SELECT unit of time on next screen (Week, Two weeks, Month, Year)

| | | |
|--------------|-------|-------------|
| \$ 1 – 9,997 | DK/RF | → GO TO A36 |
|--------------|-------|-------------|



A35PER. The rent amount entered is: [A35] per ____

- SELECT the unit of time below

| | | | |
|---------|--------------|----------|---------|
| 3. Week | 4. Two weeks | 5. Month | 6. Year |
|---------|--------------|----------|---------|

| |
|--|
| 7. Other-specify (A35PERSPEC. Specify. (String 100)) |
|--|

A36. Is this [apartment / mobile home / home] in a public housing project, that is, is it owned by a local housing authority or other public agency?

1. Yes → GO TO A37A 5. No



A37. Are you paying no rent because a Federal, State, or local government housing program is paying all of it?

1. Yes 5. No

SECTION_A.A37FOR

A37A. *A27C=FORECLOSURE STARTED*: [REINT: Other than the foreclosure experience we just talked about, since our last interview in [P2YEAR] [PYIWDATE=RESPONSE: ([PYIWDATE])], have you [or anyone in your family living there] had a home on which a foreclosure was started? / RECON: Other than the foreclosure experience we just talked about, since our last interview in [P4YEAR] [PYIWDATE=RESPONSE: ([PYIWDATE])], have you [or anyone in your family living there] had a home on which a foreclosure was started? / ALL OTHERS: Other than the foreclosure experience we just talked about, since January 1, 2001, have you [or anyone in your family living there] had a home on which a foreclosure was started?]

A27C=ALL OTHERS: [REINT: Since our last interview in [P2YEAR] [[[PYIWDATE]]], have you [or anyone in your family living there] had a home on which a foreclosure was started? / RECON: Since our last interview in [P4YEAR] [[[PYIWDATE]]], have you [or anyone in your family living there] had a home on which a foreclosure was started? / ALL OTHERS: Since January 1, 2001, have you [or anyone in your family living there] had a home on which a foreclosure was started?]

1. Yes 5. No → GO TO A42



A37B. In what month and year did the foreclosure start?

- [SELECT Month and \[Enter\] to go to next screen for year](#)
- [IF NECESSARY](#): What would be your best estimate?
- [If R says more than one foreclosure](#): Please tell us about the first of those foreclosures

| | | | | | |
|------------|-------------|--------------|-------------|--------------|--------------|
| 1. January | 2. February | 3. March | 4. April | 5. May | 6. June |
| 7. July | 8. August | 9. September | 10. October | 11. November | 12. December |
| 21. Winter | 22. Spring | 23. Summer | 24. Fall | | |

A37C. (In what month and year did the foreclosure start?)

[A37B], _____

- [ENTER Year](#): [REINT: [P2YEAR] / RECON: [P4YEAR] / ALL OTHERS: 2001] – [CYEAR]
- [If R says more than one foreclosure](#): Please tell us about the first of those foreclosures

REINTERVIEW

RECONTACT

ALL OTHERS

A37D. Was the home foreclosed upon?

- [If R says more than one foreclosure](#): Please tell us about the first of those foreclosures

1. Yes 5. No → GO TO A37F



A37E. Did you lose your home as a result of this foreclosure?

- [If R says more than one foreclosure](#): Please tell us about the first of those foreclosures

1. Yes 5. No

A37F. Was this home your main residence, investment property, a vacation home or what?

- If R says more than one foreclosure: Please tell us about the first of those foreclosures

1. Main residence 2. Investment property 3. Vacation home / condo

7. Other-specify (A37FSPEC. Please specify. (String 255))

A37G. About how much did you still owe on your mortgage or loan when the foreclosure started?

- If R says more than one foreclosure: Please tell us about the first of those foreclosures

\$ 1 – 9,999,997

END A37FOR

A42. The next few questions are about your utilities for your [apartment / mobile home / home].

Do you [and your family living there] get one bill that combines electricity, gas, and other fuel for your home? If

Yes: Would you be able to separate those amounts?

- ENTER [5] for “does not use gas”, “utilities included in rent”

1. Yes, one bill and R can report separate amounts 2. Yes, one bill but R cannot report separate amounts → GO TO A42C 5. No, not on one bill DK/RF

↓

A42A. How much do you [and your family living there] usually pay for gas or other types of fuel (for your [apartment / mobile home / home]) per month on average?

- [HU/CS IN FU: Remind R not to include amounts paid by HU or HUCS people]
- ENTER amount here, then SELECT unit of time on next screen (Month, Year)

\$ 0 → GO TO A42B \$ 1 – 9,997 DK/RF → GO TO A42B

↓

A42APER. The amount entered is: [A42A] per ____

- SELECT the unit of time below

5. Month 6. Year 7. Other-specify (A42APERSPEC. Please specify. (String 100))

A42B. (How much do you [and your family living there] usually pay...)

For electricity per month?

- [HU/CS IN FU: Remind R not to include amounts paid by HU or HUCS people]
- ENTER amount here, then SELECT unit of time on next screen (Month, Year)

\$ 0 → GO TO A43 RULE \$ 1 – 9,997 DK/RF → GO TO A43 RULE

↓

A42BPER. The amount entered is: [A42B] per ____

- SELECT the unit of time below

5. Month 6. Year 7. Other-specify (A42BPERSPEC. Please specify. (String 100))

GO TO A43 RULE

A42C. How much do you [and your family living there] usually pay for these (electricity and gas or other types of fuel) combined?

- [HU/CS IN FU: Remind R not to include amounts paid by HU or HUCS people]
- ENTER amount here, then SELECT unit of time on next screen (Month, Year)

\$ 0 → GO TO A43 RULE \$ 1 – 9,997 DK/RF → GO TO A43 RULE

↓

A42CPER. The amount entered is: [A42C] per ____

- SELECT the unit of time below

5. Month 6. Year 7. Other-specify (A42CPERSPEC. Please specify. (String 100))

A43CKPT. CAI Checkpoint: Whether Sewer/Water Included In Mobile Home Rent

| | | |
|---|--|-------------|
| 1. Not Included; Not Mobile Home (A4<>4 or (A4=4 & (A20H<>Yes & A31A<>Yes))) | 5. Included (A4=4 & (A20H=Yes or A31A=Yes)) | → GO TO A44 |
|---|--|-------------|

↓

A43. (How much do you [and your family living there] usually pay...)

For water and sewer per month?

- [HU/CS IN FU: Remind R not to include amounts paid by HU or HUCS people]
- ENTER amount here, then SELECT unit of time on next screen (Quarter, Month, Year)

→ GO TO A44 → GO TO A44



A43PER. The amount entered is: [A43] per ____

- SELECT the unit of time below

A44. (How much do you [and your family living there] usually pay...)

For telephone, including cell phone, cable or satellite TV, and internet service per month?

- Includes streaming services such as Hulu and Netflix
- [HU/CS IN FU: Remind R not to include amounts paid by HU or HUCS people]
- ENTER amount here, then SELECT unit of time on next screen (Month, Year)

→ GO TO A45 → GO TO A45



A44PER. The amount entered is: [A44] per ____

- SELECT the unit of time below

A45. And do you have any other utility expenses?

→ GO TO A40



A45A. What are those other utility expenses?

A45B. On average, how much are these other utility expenses per month?

- [HU/CS IN FU: Remind R not to include amounts paid by HU or HUCS people]
- ENTER amount here, then SELECT unit of time on next screen (Month, Year)

→ GO TO A40



A45BPER. The amount entered is: [A45B] per ____

- SELECT the unit of time below

A40. How is your [apartment / mobile home / home] heated - with gas, electricity, oil or what?

- ENTER all that apply
- PROBE: Any others?

| | | | | | | | |
|---|----------------|--------|---------|---------|----------|--------------------------|--------------|
| 1. Gas | 2. Electricity | 3. Oil | 4. Wood | 5. Coal | 6. Solar | 10. Bottled gas; propane | 11. Kerosene |
| 97. Other-specify (A40SPEC. Please specify. (String 100)) | | | | | | | |

A46. There are government programs that give money to people to help them pay for heating and cooling their homes. Did you receive help from such a program last year ([PYEAR])?

| | | |
|--------|-------|-----------------|
| 1. Yes | 5. No | → GO TO A57CKPT |
|--------|-------|-----------------|



A46A. About how much did that amount to altogether?

- If R gives a percentage, PROBE: Could you convert that into an amount? If YES, ENTER amount; if NO, PRESS [Enter] to record percentage
- ENTER dollar amount here, then SELECT unit of time on next screen (Month, Year) OR PRESS [Enter] to enter percentage

| | | | | |
|---------|----------------|--------------|-------|-----------------|
| [ENTER] | → GO TO A46PCT | \$ 1 – 9,997 | DK/RF | → GO TO A57CKPT |
|---------|----------------|--------------|-------|-----------------|



A46APER. The amount entered is: [A46A] per ____

- SELECT the unit of time below

| | | |
|----------|---------|--|
| 5. Month | 6. Year | 7. Other-specify (A46APERSPEC. Please specify. (String 100)) |
|----------|---------|--|

GO TO A57CKPT

A46PCT. (What percent did that amount to altogether?)

- ENTER a percentage from 1.0 to 100.0

| |
|---------------|
| 1.0 – 100.0 % |
|---------------|

A57CKPT. CAI Checkpoint: Respondent

| | | |
|---------------------------|--------------------|--|
| 1. R=Proxy (RESPONDENT=7) | → GO TO SECTION BC | 5. R=Head, Spouse/Partner, OFUM (RESPONDENT=1-4) |
|---------------------------|--------------------|--|



SECTION_A.A57[1-2] [1]=Current Head, [2]=Current Spouse/Partner

AQSN. AQSN of Current Head (Spouse/Partner)

A57A. [CYNAMF CYNAML], [CYAQRTH, [CYFUHU], AGE [AGEIWDATE] [(Respondent)]

[Do you / Does [HEAD / SP]] have a computer, laptop, or tablet that [you / he / she] can use at home?

- If needed: Include devices that [you / he / she] might bring home to do work related to [your / his / her] job.
- If needed: A tablet is used by touching the screen, like the iPad, Samsung Galaxy, Motorola Xoom, or Kindle Fire.

| | | |
|--------|-------|--------------|
| 1. Yes | 5. No | → GO TO A57D |
|--------|-------|--------------|



A57B. [CYNAMF CYNAML], [CYAQRTH, [CYFUHU], AGE [AGEIWDATE] [(Respondent)]

In the past month, how often [have you / has [he / she]] gone on the Internet using a computer, laptop, or tablet at home?

Would you say every day, a few times a week, once a week, less than once a week, or never?

| | | | | | |
|--------------|-----------------------|----------------|--------------------------|----------|-------|
| 1. Every day | 2. A few times a week | 3. Once a week | 4. Less than once a week | 5. Never | DK/RF |
|--------------|-----------------------|----------------|--------------------------|----------|-------|

GO TO A57E



A57C. [CYNAMF CYNAML], [CYAQRTH, [CYFUHU], AGE [AGEIWDATE] [(Respondent)]

In the past year, [have you / has [he / she]] gone on the Internet using a computer, laptop, or tablet at home?

1. Yes → GO TO A57E 5. No



A57D. [CYNAMF CYNAML], [CYAQRTH, [CYFUHU], AGE [AGEIWDATE] [(Respondent)]

In the past year, [have you / has [he / she]] gone on the Internet using a computer, laptop, or tablet somewhere other than [your / his / her] home?

1. Yes 5. No

A57E. [CYNAMF CYNAML], [CYAQRTH, [CYFUHU], AGE [AGEIWDATE] [(Respondent)]

[Do you / Does [HEAD / SP]] have a smart phone that [you / he / she] can use to go on the Internet?

1. Yes 5. No → GO TO A57J



A57F. [CYNAMF CYNAML], [CYAQRTH, [CYFUHU], AGE [AGEIWDATE] [(Respondent)]

In the past month, how often [have you / has [he / she]] sent or received text messages on [your / his / her] smart phone?

Would you say every day, a few times a week, once a week, less than once a week, or never?

1. Every day 2. A few times a week 3. Once a week 4. Less than once a week 5. Never

A57G. [CYNAMF CYNAML], [CYAQRTH, [CYFUHU], AGE [AGEIWDATE] [(Respondent)]

In the past month, how often [have you / has [he / she]] used [your / his / her] smart phone to access email or other websites on the Internet?

(Would you say every day, a few times a week, once a week, less than once a week, or never?)

1. Every day 2. A few times a week 3. Once a week 4. Less than once a week 5. Never DK/RF

GO TO A57LCKPT



A57H. [CYNAMF CYNAML], [CYAQRTH, [CYFUHU], AGE [AGEIWDATE] [(Respondent)]

In the past year, [have you / has [he / she]] used [your / his / her] smart phone to access email or other websites on the Internet?

1. Yes 5. No

GO TO A57LCKPT

A57J. [CYNAMF CYNAML], [CYAQRTH, [CYFUHU], AGE [AGEIWDATE] [(Respondent)]

[Do you / Does [HEAD / SP]] have a cell phone?

1. Yes 5. No → GO TO A57LCKPT



A57K. [CYNAMF CYNAML], [CYAQRTH, [CYFUHU], AGE [AGEIWDATE] [(Respondent)]

In the past month, how often [have you / has [he / she]] sent or received text messages on [your / his / her] cell phone?

(Would you say every day, a few times a week, once a week, less than once a week, or never?)

1. Every day 2. A few times a week 3. Once a week 4. Less than once a week 5. Never

A57LCKPT. CAI Checkpoint: Whether Head (Spouse/Partner) Has Not Used Internet in Past Year

| | | |
|---|-------------------------|--------------------|
| 1. Has Not Used Internet (A57A=No, DK/RF or (A57C=No, DK/RF & A57D=No, DK/RF)) & (A57E=No, DK/RF or (A57G=Never, DK/RF & A57H=No, DK/RF)) | → GO TO A57 END RULE | 5. All Others ↓ |
|---|-------------------------|--------------------|

A57L. [CYNAMF CYNAML], [CYAQRTH, [CYFUHU], AGE [AGEIWDATE] [(Respondent)]

In the past month, how often [have you / has [he / she]] used email?

(Would you say every day, a few times a week, once a week, less than once a week, or never?)

| | | | | | |
|--------------------|-----------------------|----------------|--------------------------|----------|-------|
| 1. Every day | 2. A few times a week | 3. Once a week | 4. Less than once a week | 5. Never | DK/RF |
| GO TO A57 END RULE | | | | | ↓ |

A57M. [CYNAMF CYNAML], [CYAQRTH, [CYFUHU], AGE [AGEIWDATE] [(RESPONDENT)]

In the past year, [have you / has [he / she]] used email?

| | |
|--------|-------|
| 1. Yes | 5. No |
|--------|-------|

A57 END Rule: Whether Spouse/Partner in FU

| | | |
|---|--|------------------------|
| Spouse/Partner (CYAQRTH=201-222, CYFUHU=FU, FUMI) | → Repeat A57A-A57M; Then GO TO SECTION BC | No Spouse/Partner ↓ |
|---|--|------------------------|

END A57

END SECTION_A

Section BC: Employment

[TOC](#)

EMPLOYEEHC1[1-2] ([1]Current Head, [2]Current Spouse/Partner)

BCDE1. [CYNAMF CYNAML]: [CYAQRTH], [CYFUHU], Age [AGEIWDATE] [(Respondent)]

We would like to know about what [you do / [HEAD / SP] does] - [are you / is [HEAD / SP]] working now, looking for work, retired, keeping house, a student, or what?

- If R says “Unemployed/Not working”, PROBE: [Are you / Is [HEAD / SP]] looking for work?
 - If unemployed/not working and looking for work, ENTER [3]
 - If unemployed/not working and not looking for work, ENTER [6]
- ENTER all that apply
- PROBE: Anything else?

| | | | |
|----------------|---|--|--|
| 1. Working now | 2. Only temporarily laid off, sick or maternity leave | 3. Looking for work, unemployed | 4. Retired |
| | | 5. Disabled, permanently or temporarily | ↓ |
| | | 6. Keeping house | 7. Student |
| GO TO EHCINTRO | | 8. Other-specify (BCDE1SPEC. Please tell me what [you are / [HEAD / SP] is] doing now. (String 100)) | BCDE2. [CYNAMF CYNAML]: [CYAQRTH], [CYFUHU], Age [AGEIWDATE] [(Respondent)] In what year did [you / [HEAD / SP]] (last) retire? |
| | | DK/RF | 1901 – [CYEAR] |

↓

BCDE3. [CYNAMF CYNAML]: [CYAQRTH], [CYFUHU], Age [AGEIWDATE] [(Respondent)]

[Are you / Is [he / she]] doing any work for money now?

1. Yes → GO TO EHCINTRO 5. No

↓

BCDE3A. [CYNAMF CYNAML]: [CYAQRTH], [CYFUHU], Age [AGEIWDATE] [(Respondent)]

[Have you / Has [HEAD / SP]] done any work for money since January 1, [P2YEAR]? Please include any type of work, no matter how small.

1. Yes 5. No

EHCINTRO. [CYNAMF CYNAML]: [CYAQRTH], [CYFUHU], Age [AGEIWDATE] [(Respondent)]

Next, I will be asking you about [BCDE1=WORKING, LAID OFF or BCDE3=WORKING NOW or BCDE3A=HAS WORKED: jobs [you / [HEAD / SP]] had / ALL OTHERS: what [you have / [HEAD / SP] has] done] and places [you have / [HEAD / SP] has] lived during the past two years.

- ENTER [1] to go into [CYNAMF CYNAML]'s employment EHC

1. Continue

Residence Domain

[CYNAMF CYNAML]: [CYAQRTH], [CYFUHU], Age [AGEIWDATE] [(Respondent)] End date of calendar is [IWSTARTDATE]
 Max 6 timelines; Asked on Head EHC only; Dependent Interviewing for REINTERVIEW - timeline #1 preloaded with last wave
 Address/Start Date IF preload is Response **and** Head is same Head as last wave.

[SP LOOP: IWER: Residence domain is disabled because this is the Spouse/Partner EHC]

- [PRELOADED RESIDENCE: IWER: Residence timeline #1 has been preloaded with [HEAD]'s [P2YEAR] residence. CLICK on address label (left-column) and PROBE whether this is still [his / her] current residence. VERIFY and EDIT Start Date and Address as needed. / ALL OTHERS: What is the street address and move-in date of [your / [HEAD]'s] current residence?]
- [PRELOADED RESIDENCE: If needed:] [Have you / Has [he / she]] lived anywhere else since January [P2YEAR]? IF YES: Please tell me the address of each of those residences and the dates [you / he / she] lived there.
 PROBE for full address
 If R says "Homeless", ENTER [Homeless] in the Address field for that timeline
 IWER: By "Winter" we mean Dec, Jan and Feb in that order and overlapping 2 calendar years. If R says "Winter", PROBE whether that is late in the year (Dec) or early in the following year (Jan, Feb).

LANDMARKRESIDENCESECTION.RESECTION[1-6] [1-6]=Which residence

sADDRESS. ISCURRENT. Current residence SAMERES. Preload residence current (Reint)

sCITY.

sSTATE.

sZIP.

sCOUNTRY.

SMONTHSEASON; EMONTHSEASON. Starting and Ending Month/Season

| | | | | |
|---|---|--|---|---------------------------------|
| <input type="text" value="21. Winter"/> | <input type="text" value="12. December"/> | <input type="text" value="1. January"/> | <input type="text" value="2. February"/> | <input type="text" value="DK"/> |
| <input type="text" value="22. Spring"/> | <input type="text" value="3. March"/> | <input type="text" value="4. April"/> | <input type="text" value="5. May"/> | |
| <input type="text" value="23. Summer"/> | <input type="text" value="6. June"/> | <input type="text" value="7. July"/> | <input type="text" value="8. August"/> | |
| <input type="text" value="24. Fall"/> | <input type="text" value="9. September"/> | <input type="text" value="10. October"/> | <input type="text" value="11. November"/> | |

SDAY; EDAY. Starting and Ending Day/3rd of Month

| | | | | | | | | | | | |
|---|---------------------------------|---------------------------------|---------------------------------|---------------------------------|---------------------------------|---------------------------------|---------------------------------|---------------------------------|---------------------------------|---------------------------------|---------------------------------|
| <input type="text" value="41. First third"/> | <input type="text" value="1"/> | <input type="text" value="2"/> | <input type="text" value="3"/> | <input type="text" value="4"/> | <input type="text" value="5"/> | <input type="text" value="6"/> | <input type="text" value="7"/> | <input type="text" value="8"/> | <input type="text" value="9"/> | <input type="text" value="10"/> | <input type="text" value="DK"/> |
| <input type="text" value="42. Middle third"/> | <input type="text" value="11"/> | <input type="text" value="12"/> | <input type="text" value="13"/> | <input type="text" value="14"/> | <input type="text" value="15"/> | <input type="text" value="16"/> | <input type="text" value="17"/> | <input type="text" value="18"/> | <input type="text" value="19"/> | <input type="text" value="20"/> | |
| <input type="text" value="43. Last third"/> | <input type="text" value="21"/> | <input type="text" value="22"/> | <input type="text" value="23"/> | <input type="text" value="24"/> | <input type="text" value="25"/> | <input type="text" value="26"/> | <input type="text" value="27"/> | <input type="text" value="28"/> | <input type="text" value="29"/> | <input type="text" value="30"/> | |

SYEAR; EYEAR. Starting and Ending Year

1901- [P3YEAR]. Before [P2YEAR] → Enter Year 1901-[P3YEAR]

Past Residence(s)

A50. Why did [you / he / she] move?

- If "Homeless", DO NOT READ question-SELECT[9]
- ENTER all that apply
- PROBE: Any other reasons?

| | | |
|--|---|-------------------------------------|
| <input type="text" value="1. Take a job; stopped school"/> | <input type="text" value="2. Nearer to work"/> | |
| <input type="text" value="3. More space; better place"/> | <input type="text" value="4. Smaller; less expensive"/> | |
| <input type="text" value="5. Get own home/place; got married"/> | | |
| <input type="text" value="6. Better area; close to family"/> | | |
| <input type="text" value="7. Evicted; divorced; job transfer; foreclosed"/> | | |
| <input type="text" value="8. Other-specify (A50OTHER. Specify (String 200))"/> | | |
| <input type="text" value="9. Homeless"/> | <input type="text" value="10. DK"/> | <input type="text" value="11. RF"/> |

Current Residence

A51. Do you think [you / he / she] might move in the next couple of years?

→ EXIT



A52. Would you say [you / he / she] definitely will move, probably will move, or are you more uncertain?

A53. Why [will/might] [you/ he / she] move?

For Don't Know type [DK]; For Refusal, type [RF]

END RESECTION

Employment Domain

[CYNAMF CYNAML]: [CYAQRTH], [CYFUHU], Age [AGEIWDAT] [(Respondent)] End date of calendar is [IWSTARTDATE] Max 10 timelines; Disabled if BCDE3=No, DK/RF and BCDE3A=No, DK/RF; Dependent Interviewing for REINTERVIEW - timeline#1 preloaded with last wave CMJ IF preload is Response **and** Head (Spouse/Partner) is same Head (Spouse/Partner) as last wave.

I'd like to know about all of the work for money that [you have / [HEAD / SP has]] done since January 1, [P2YEAR]. Please include self-employment and any other kind of work that [you have / [he / she] has] done for pay. [PRELOADED TIMELINE: IWER: Employment timeline #1 has been preloaded with [HEAD / SP]'s [P2YEAR] current main job. CLICK on employer name (left-column) and PROBE whether this is still a current job. VERIFY and EDIT Start Date and Employer as needed. / ALL OTHERS: Start with any job that [you / [HEAD / SP]] had during this time.]

1. [PRELOADED CMJ: If needed:] What (is / was) the name of this employer?
2. [PRELOADED CMJ: If needed:] When did [you / [HEAD / SP]] start and when did [you / he / she] stop working for this employer? Please give me all of [your / his / her] start and stop dates if [you have / [he / she] has] worked for (yourself / himself / herself / this employer) more than once.

Before exiting this domain, probe for any other work for pay, no matter how small.

IF NECESSARY: This information will help us to process employment information you gave us. The name itself will never be released as part of data from the study.

If no employer name is given by R, ask for job title or anything that can help identify the job.

By "Winter" we mean Dec, Jan and Feb in that order and overlapping 2 calendar years. If R says "Winter", PROBE whether that is late in the year (Dec) or early in the following year (Jan, Feb).

EMPLOYEEHC1[1-2].EMPLOYSECTION[1-10] [1-10]=Which employer

AQSN. AQSN of Current Head (Spouse/Partner)

EMPLOYER. Name of employer ISCURRENT. Whether job is current SAMECMJ. Preload CMJ current (Reint)

| | | | |
|------------|-------|----------------|-----------------------------------|
| String 100 | DK/RF | 0. Not checked | 1. IsCurrent=1/ Same as last wave |
| | | 1. Checked | 5. IsCurrent=0/No longer current |

SMONTHSEASON; EMONTHSEASON. Starting and Ending Month/Season

| | | | | |
|------------|--------------|-------------|--------------|----|
| 21. Winter | 12. December | 1. January | 2. February | DK |
| 22. Spring | 3. March | 4. April | 5. May | |
| 23. Summer | 6. June | 7. July | 8. August | |
| 24. Fall | 9. September | 10. October | 11. November | |

SDAY; EDAY. Starting and Ending Day/3rd of Month

| | | | | | | | | | | | |
|------------------|----|----|----|----|----|----|----|----|----|----|----|
| 41. First third | 1 | 2 | 3 | 4 | 5 | 6 | 7 | 8 | 9 | 10 | DK |
| 42. Middle third | 11 | 12 | 13 | 14 | 15 | 16 | 17 | 18 | 19 | 20 | |
| 43. Last third | 21 | 22 | 23 | 24 | 25 | 26 | 27 | 28 | 29 | 30 | |

SYEAR; EYEAR. Starting and Ending Year

| | | | |
|----------------------------|-------------------------------|---------|--|
| [P2YEAR] | [PYEAR] | [CYEAR] | 1901- [P3YEAR]. Before [P2YEAR] → Enter Year 1901-[P3YEAR] |
| 9997. DK (Before [P2YEAR]) | 9998. DK ([P2YEAR] - [CYEAR]) | | |

END EMPLOYSECTION

Time Away Domain

[CYNAMF CYNAML]: [CYAQRTH], [CYFUHU], Age [AGEIWDATE] [(Respondent)]

Max 5 timelines per REASON; Disabled if BCDE3=No, DK/RF and BCDE3A=No, DK/RF.

1. While [you were / [HEAD / SP] was] employed during [PYEAR], did [you / he / she] miss any work because someone else was sick?
2. (Did [you / he / she] miss any work) because [you were / [he / she] was] sick?
3. (Did [you / he / she] miss any work) for a vacation or time off?
4. (Did [you / he / she] miss any work) because [you were / [he / she] was] on strike?
5. (Did [you / he / she] miss any work) because [you were / [he / she] was] temporarily laid off from work?

If Yes: When was that (or how much time was that) (in [PYEAR])?

PROBE each type of Time Away: Any others?

If R can remember dates, ENTER Start and End dates; Otherwise, CHECK "Don't Know When" box and ENTER duration of Months, Weeks, Days

By "Winter" we mean Dec, Jan and Feb in that order and overlapping 2 calendar years. If R says "Winter", PROBE whether that is late in the year (Dec) or early in the following year (Jan, Feb).

EMPLOYEEHC1[1-2].TIMEAWAYSECTION(2, 3, 4, 5)[1-5] [1-5]=Which time away per REASON

AQSN. AQSN of Current Head (Spouse/Partner)

REASON. Time Away Timelines per PYEAR

| | | | | |
|----------------------|-------------|-------------|--------------|---------------------|
| 1. Someone else sick | 2. Own sick | 3. Vacation | 4. On strike | 5. Temporary layoff |
|----------------------|-------------|-------------|--------------|---------------------|

MONTHSEASON; EMONTHSEASON. Starting and Ending Month/Season

| | | | | |
|------------|--------------|-------------|--------------|----|
| 21. Winter | 12. December | 1. January | 2. February | DK |
| 22. Spring | 3. March | 4. April | 5. May | |
| 23. Summer | 6. June | 7. July | 8. August | |
| 24. Fall | 9. September | 10. October | 11. November | |

SDAY; EDAY. Starting and Ending Day/3rd of Month

| | | | | | | | | | | | |
|------------------|----|----|----|----|----|----|----|----|----|----|----|
| 41. First third | 1 | 2 | 3 | 4 | 5 | 6 | 7 | 8 | 9 | 10 | DK |
| 42. Middle third | 11 | 12 | 13 | 14 | 15 | 16 | 17 | 18 | 19 | 20 | |
| 43. Last third | 21 | 22 | 23 | 24 | 25 | 26 | 27 | 28 | 29 | 30 | 31 |

SYEAR; EYEAR. Starting and Ending Year

| |
|---------|
| [PYEAR] |
|---------|

TIME AWAY Rule

| |
|--|
| [DK When] Selected; or SMonth/EMonth=DK; or SMonth=EMonth & SDay/EDay=DK |
| ↓ |

Don't Know When During PYEAR

| | | |
|---------------|--------|----|
| DKWHENMONTHS. | 0 – 12 | DK |
| DKWHENWEEKS. | 0 – 3 | DK |
| DKWHENDAYS. | 0 – 31 | DK |

END TIMEAWAYSECTION

Not Working Domain

[CYNAMF CYNAML]: [CYAQRTH], [CYFUHU], Age [AGEIWDATE] [(Respondent)]

Max 5 timelines per LOOKNOT, per PYEAR and P2YEAR.

1. Were there any times during [P2YEAR] when [you were / [HEAD / SP] was] not employed (not working at all for pay)? **IF YES:**
 [Were you / Was [he / she]] looking for a job, or not looking (for a job)?

PROBE: When was that (or how much time was that) (when [you were / [he / she] was] (looking / not looking) in [P2YEAR])?

2. Were there any times during [PYEAR] when [you were / [HEAD / SP] was] not employed (not working at all for pay)? **IF YES:** [Were you / Was [he / she]] looking for a job, or not looking (for a job)?

PROBE: When was that (or how much time was that) (when [you were / [he / she] was] (looking / not looking) in [PYEAR])?

If R can remember dates, ENTER Start and End dates; Otherwise, CHECK "Don't Know When" box and ENTER duration of Months, Weeks, Days

By "Winter" we mean Dec, Jan and Feb in that order and overlapping 2 calendar years. If R says "Winter", PROBE whether that is late in the year (Dec) or early in the following year (Jan, Feb).

EMPLOYEEHC1[1-2].NOTWORKSECTION(2, 3, 4)[1-5] [1-5]=Which time away per LOOKNOT per P2YEAR/PYEAR
 AQSN. AQSN of Current Head (Spouse/Partner)

LOOKNOT. Not Working Timelines per P2YEAR/PYEAR

| | |
|------------|----------------|
| 1. Looking | 2. Not looking |
|------------|----------------|

SMONTHSEASON; EMONTHSEASON. Starting and Ending Month/Season

| | | | | |
|------------|--------------|-------------|--------------|----|
| 21. Winter | 12. December | 1. January | 2. February | DK |
| 22. Spring | 3. March | 4. April | 5. May | |
| 23. Summer | 6. June | 7. July | 8. August | |
| 24. Fall | 9. September | 10. October | 11. November | |

SDAY; EDAY. Starting and Ending Day/3rd of Month

| | | | | | | | | | | | |
|------------------|----|----|----|----|----|----|----|----|----|----|----|
| 41. First third | 1 | 2 | 3 | 4 | 5 | 6 | 7 | 8 | 9 | 10 | DK |
| 42. Middle third | 11 | 12 | 13 | 14 | 15 | 16 | 17 | 18 | 19 | 20 | |
| 43. Last third | 21 | 22 | 23 | 24 | 25 | 26 | 27 | 28 | 29 | 30 | 31 |

SYEAR; EYEAR. Starting and Ending Year

| |
|----------|
| [P2YEAR] |
| [PYEAR] |

NOT WORKING Rule

| |
|--|
| [DK When] Selected; or SMonth/EMonth=DK; or SMonth=EMonth & SDay/EDay=DK |
| ↓ |

Don't Know When During [PYEAR/P2YEAR] [Looking / Not Looking]

| | | |
|---------------|--------|----|
| DKWHENMONTHS. | 0 – 12 | DK |
| DKWHENWEEKS. | 0 – 3 | DK |
| DKWHENDAYS. | 0 – 31 | DK |

END NOTWORKSECTION

CONFIRMSAMECMJ Rule: Whether Edits Made in EHC to Name or Date of Preloaded CMJ

| | | |
|-------|----------|---------------------|
| Edits | No Edits | → GO TO BCDE14ACKPT |
| ↓ | | |

CONFIRMSAMECMJ. [CYNAMF CYNAML]: [CYAQRTH], [CYFUHU], Age [AGEIWDATE] [(Respondent)]

[EHC CMJ] ([EHC MO/DY/YR])

Interviewer checkpoint:

You made changes to the preloaded current main job (CMJ) in the EHC:

CMJ preloaded from last wave: [PRELOAD CMJ] ([PRELOAD CMJ MO/DY/YR])

CMJ with edits this wave: [EHC CMJ] ([EHC MO/DY/YR])

Is the CMJ for this wave the same job as the CMJ that was preloaded from last wave?

ASK R if needed

| | |
|-------------------------------|--------------------------------|
| 1. Yes, same job as last wave | 5. No, different job this wave |
|-------------------------------|--------------------------------|

BCDE14ACKPT. CAI Checkpoint: Whether Head (Spouse/Partner) Had Job in PYEAR

| | | |
|---|---|---|
| 1. No Jobs PYEAR (BCDEWTRPY=0 For All Jobs) GO TO BCDE14DCKPT | Jobs PYEAR (BCDEWTRPY=1 For Any Job) | |
| | 3. Can't Compute Weeks Worked (BCDEDKJOBSPY=1) | 5. Weeks Worked Computed (BCDEWTRPY=1 Any Job, BCDEDKJOBSPY=0) |
| GO TO BCDE14B | | ↓ |

BCDE14A. [CYNAMF CYNAML]: [CYAQRTH], [CYFUHU], Age [AGEIWDATE] [(Respondent)]

[EMPLOYMENT SUMMARY](#)

[\[List of PYEAR Employers from EHC\]](#)

From the information you have given me on [2 JOBS: both of / >2 JOBS: all of] [your / [HEAD / SP]'s] [1 JOB: job / 2+ JOBS: jobs], [you were / [he / she] was] employed approximately [#WEEKS] out of 52 weeks in [PYEAR]. Does this sound correct?

| | | |
|--------|------------------|-------|
| 1. Yes | → GO TO BCDE14BB | 5. No |
|--------|------------------|-------|

↓

BCDE14B. [CYNAMF CYNAML]: [CYAQRTH], [CYFUHU], Age [AGEIWDATE] [(Respondent)]

[EMPLOYMENT SUMMARY](#)

[\[List of PYEAR Employers from EHC\]](#)

Thinking about [your / [HEAD / SP]'s] work in [PYEAR], how many weeks did [you / he / she] actually work on [all of] [your / his / her] [job / jobs] in [PYEAR], not counting time off for vacations, sick time, unemployment, etc.?

| | | | |
|---|-----------------|--------|-------|
| 0 | → GO TO BCDE14C | 1 - 52 | DK/RF |
|---|-----------------|--------|-------|

↓

BCDE14BB. [CYNAMF CYNAML]: [CYAQRTH], [CYFUHU], Age [AGEIWDATE] [(Respondent)]

[EMPLOYMENT SUMMARY](#)

[\[List of PYEAR Employers from EHC\]](#)

On average, how many hours a week did [you / he / she] work on [all of] [your / his / her] [job / jobs] during [PYEAR]?

- ROUND DOWN for fractions less than ½ (0.5)
- ROUND UP for fractions ½ (0.5) or more

| | | |
|---------|-------|---------------------|
| 1 - 112 | DK/RF | → GO TO BCDE14DCKPT |
|---------|-------|---------------------|

↓

BCDE4B3. [CYNAMF CYNAML]: [CYAQRTH], [CYFUHU], Age [AGEIWDATE] [(Respondent)]
EMPLOYMENT SUMMARY
 [List of PYEAR Employers from EHC]

Did [you / he / she] work any overtime which isn't included in that?

1. Yes 5. No → GO TO BCDE14DCKPT



BCDE14B4. [CYNAMF CYNAML]: [CYAQRTH], [CYFUHU], Age [AGEIWDATE] [(Respondent)]
EMPLOYMENT SUMMARY
 [List of PYEAR Employers from EHC]

How many hours did that overtime amount to (on [all of] [your / his / her] [job / jobs] in [PYEAR])?

- ENTER amount here, then SELECT unit of time on next screen (Week, Two weeks, Month, Year)
- ROUND DOWN for fractions less than ½ (0.5)
- ROUND UP for fractions ½ (0.5) or more

1 – 3760 DK/RF → GO TO BCDE14DCKPT



BCDE14B4PER. The amount entered is: [BCDE14B4] per ____

- SELECT the unit of time below

3. Week 4. Two weeks 5. Month 6. Year

7. Other-specify (BCDE14B4PERSPEC. Please specify. (String 100))

GO TO BCDE14DCKPT

BCDE14C. [CYNAMF CYNAML]: [CYAQRTH], [CYFUHU], Age [AGEIWDATE] [(Respondent)]

IWER: The EHC indicates that [HEAD / SP] had a job in [PYEAR], but BCDE14B is '00' for total weeks worked in [PYEAR]. Please explain why.

EMPLOYMENT SUMMARY
 [List of PYEAR Employers from EHC]

String 500

BCDE14DCKPT. CAI Checkpoint: Whether Head (Spouse/Partner) Had Job inP2YEAR

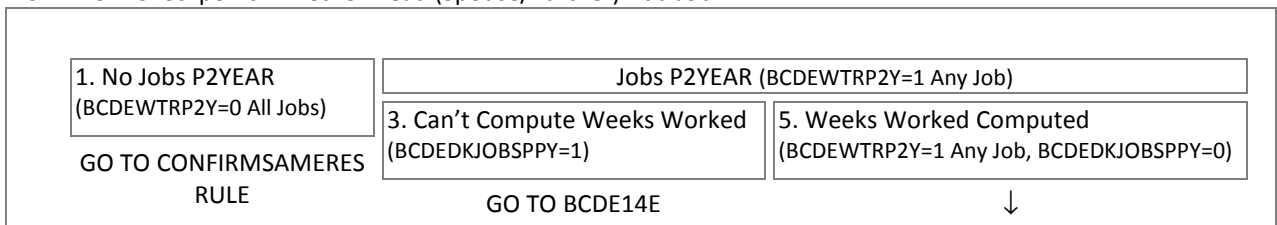

BCDE14D. [CYNAMF CYNAML]: [CYAQRTH], [CYFUHU], Age [AGEIWDATE] [(Respondent)]

EMPLOYMENT SUMMARY
 [List of PY2EAR Employers from EHC]

For the year before last, [P2YEAR], from the information you have given me on [both of / all of] [your / your / [HEAD / SP]'s] [job / jobs], [you were / [he / she] was] employed approximately [#WEEKS] out of 52 weeks in [P2YEAR]. Does this sound correct?

1. Yes → GO TO BCDE14EE 5. No



BCDE14E. [CYNAMF CYNAML]: [CYAQRTH], [CYFUHU], Age [AGEIWDATE] [(Respondent)]

EMPLOYMENT SUMMARY

[List of PY2EAR Employers from EHC]

Thinking about [your / your / [HEAD / SP]'s] work in [P2YEAR], how many weeks did [you / he / she] actually work on [all of] [your / his / her] [job / jobs] in [PYEAR], not counting time off for vacations, sick time, unemployment, etc.?

→ GO TO BCDE14F



BCDE14EE. [CYNAMF CYNAML]: [CYAQRTH], [CYFUHU], Age [AGEIWDATE] [(Respondent)]

EMPLOYMENT SUMMARY

[List of PY2EAR Employers from EHC]

On average, how many hours a week did [you / he / she] work on [all of] [your / his / her] [job / jobs] during [P2YEAR]?

- ROUND DOWN for fractions less than ½ (0.5)
- ROUND UP for fractions ½ (0.5) or more

GO TO SAME RESIDENCE RULE

BCDE14F. [CYNAMF CYNAML]: [CYAQRTH], [CYFUHU], Age [AGEIWDATE] [(Respondent)]

IWER: The EHC indicates that [HEAD / SP] had a job in [P2YEAR], but BCDE14E is '00' for total weeks worked in [P2YEAR]. Please explain why.

EMPLOYMENT SUMMARY

[List of PY2EAR Employers from EHC]

CONFIRMSAMERES Rule: Whether Edits Made in EHC to Name or Date of Preloaded Residence

| | | |
|------------------------------------|---------------------------------------|------------------|
| <input type="text" value="Edits"/> | <input type="text" value="No Edits"/> | → GO TO BC15CKPT |
| ↓ | | |

CONFIRMSAMERES. [CYNAMF CYNAML]: [CYAQRTH], [CYFUHU], Age [AGEIWDATE] [(Respondent)]

Interviewer checkpoint:

You made changes to the preloaded residence in the EHC:

Residence preloaded from last wave: [PRELOAD RES CITY, STATE, ZIP] ([PRELOAD RES MO/DY/YR])

Residence with edits this wave: [EHC RES] ([EHC MO/DY/YR])

Is the address for this wave the same residence as the address that was preloaded from last wave?

ASK R if needed

END EMPLOYEHC1

JOB INDICATORS:

BCWTRWRK WHETHER WORKED SINCE 1/1/P2YEAR (1: BCDE1=1, 2 or BCDE3=YES or BCDE3A=YES; 0: BCDE1<>1, 2 and BCDE3<>YES and BCDE3A<>YES)

BCJOBNUM SEQUENTIAL JOB ID, THE MAX ALLOWED IS 10;

BCEMPNAME EMPLOYER NAME, NEEDED FOR FILL / IWER REFERENCE;

BCWTRP2YEAR WTR WORKED DURING P2YEAR FOR THIS EMPLOYER (1, 0);

BCWTRP1YEAR WTR WORKED DURING PYEAR FOR THIS EMPLOYER (1, 0);

BCWTRCYEAR WTR WORKED DURING CYEAR FOR THIS EMPLOYER (1, 0);

BCCUR WTR CURRENT EMPLOYER (1, 0);

BCMOSTREC WTR MOST RECENT EMPLOYER (1, 0); 0 IF ANY OTHER JOB IS BCCUR=1;

BCACCDATE WTR START (& STOP DATE, IF APPLICABLE) ARE KNOWN TO MONTH LEVEL (1, 0);

PYEAR INDICATORS:

BCDKJobsP1YR=1 CAN'T COMPUTE WEEKS WORKED (BCDE14B=0, DK, RF)

BCEDKHoursP1YR=1 CAN'T COMPUTE HOURS PER WEEK WORKED (BCDE14B=0 OR BCDE14BB=DK, RF)

BCDKOT1YR=1 CAN'T COMPUTE OVERTIME WORKED (BCDE14B=0 OR BCDE14BB=DK, RF OR BCDE14B3=DK, RF OR BCDE14B4=DK, RF)

P2YEAR INDICATORS:

BCDKJobsP2YR=1 CAN'T COMPUTE WEEKS WORKED (BCDE14E=0, DK, RF)

BCDKHoursP2YR=1 CAN'T COMPUTE HOURS PER WEEK WORKED (BCDE14E=0 OR BCDE14EE=DK, RF)

SECTION_BC[1-2] [1]=Current Head, [2]=Current Spouse/Partner

BCAQSN. AQSN of Current Head (Spouse/Partner)

SECTION_BC[1-2].BCJOBS[1-10] [1]=Current Head, [2]=Current Spouse/Partner; [1-10]=Which employer

BC15CKPT. CAI Checkpoint: Number and Type(s) of Job

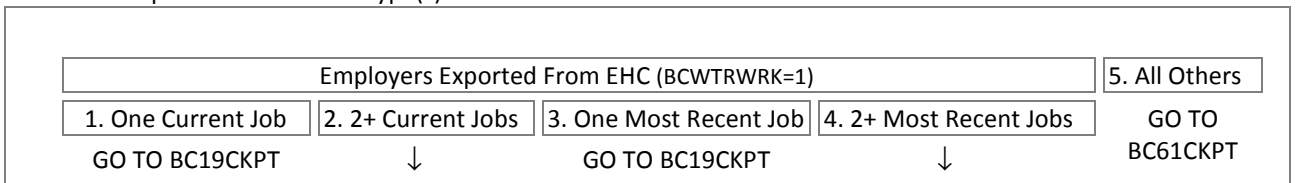

BC16. [CYNAMF CYNAML]: [CYAQRTH], [CYFUHU], Age [AGEIWDAT] [(Respondent)]

You have just told me that [you are / [HEAD / SP] is] working now for more than one employer. Which one of these jobs do you consider to be [your / his / her] main job?

- [READ list of employers/jobs if needed](#)

1 – 10. [EMPNAME] *List of current employers*

DK, RF NOT ALLOWED

ASSIGN BC18.JOBTYPE=CMJ FOR SELECTION

BC17. [CYNAMF CYNAML]: [CYAQRTH], [CYFUHU], Age [AGEIWDAT] [(Respondent)]

You mentioned [#] jobs that ended at the same time. Which one of these jobs do you consider to have been [your / his / her] main job?

- [READ list of employers/jobs if needed](#)

1 – 10. [EMPNAME] *List of non-current employers*

DK, RF NOT ALLOWED

ASSIGN BC18.JOBTYPE=MRMJ FOR SELECTION

BC19CKPT. CAI Checkpoint: Whether Head (Spouse/Partner) Worked This Job in PYEAR-CYEAR

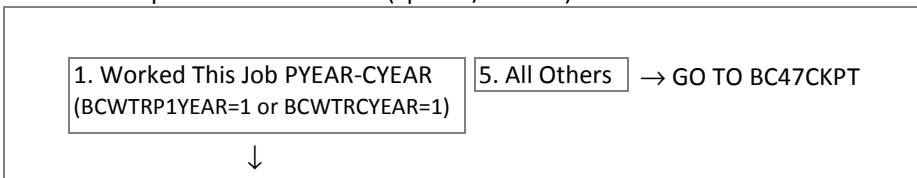

BC19BCKPT. CAI Checkpoint: Whether Same CMJ as Last Wave

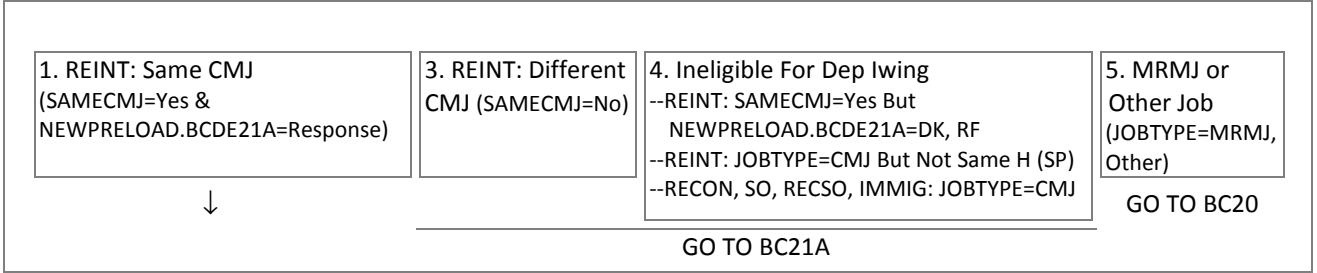

Dependent Interviewing for Reinterviews

REINT: Same CMJ

BC19B. [CYNAMF CYNAML]: [CYAQRTH], [CYFUHU], Age [AGEIWDAT] [(Respondent)]

EMPLOYER: [EMPNAME] [(BEGMO/BEGYR)-[ENDMO/ENDYR])

At our last interview [PYIWDAT=RESPONSE: on [PYIWDAT] / ALL OTHERS: in [P2YEAR]], we recorded [your / [HEAD / SP]'s] job title at [EMPNAME] [(BEGMO/BEGYR)-[ENDMO/ENDYR]) as [PRELOAD BCDE21A].

Is this [your / his / her] current job title?

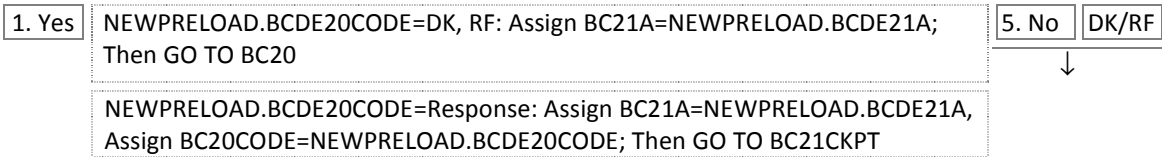

Dependent Interviewing for Reinterviews

REINT: Same CMJ & BC19B=No, DK/RF, or Not Same CMJ, or INEL

RECON, SO, RECSO: CMJ

BC21A. [CYNAMF CYNAML]: [CYAQRTH], [CYFUHU], Age [AGEIWDAT] [(Respondent)]

EMPLOYER: [EMPNAME] [(BEGMO/BEGYR)-[ENDMO/ENDYR])

What is the official title of [your / [HEAD / SP]'s] job? (The title that [your / his / her] employer uses.)

String 200

BC20 RULE: Whether Same CMJ as Last Wave; Whether Same Job Title as Last Wave

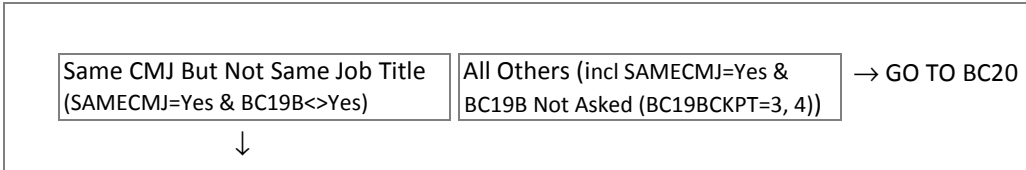

Dependent Interviewing for Reinterviews

REINT: Same CMJ & BC19B=No, DK/RF

BC20CKPT. [CYNAMF CYNAML]: [CYAQRTH], [CYFUHU], Age [AGEIWDAT] [(Respondent)]

EMPLOYER: [EMPNAME] [(BEGMO/BEGYR)-[ENDMO/ENDYR])

Interviewer Checkpoint: You entered that [HEAD / SP]'s job title for this job has changed from [PRELOAD BCDE21A] to [BC21A]. Did R mention that the sort of work [HEAD / SP] does - job duties and activities - are the same even though the job title has changed?

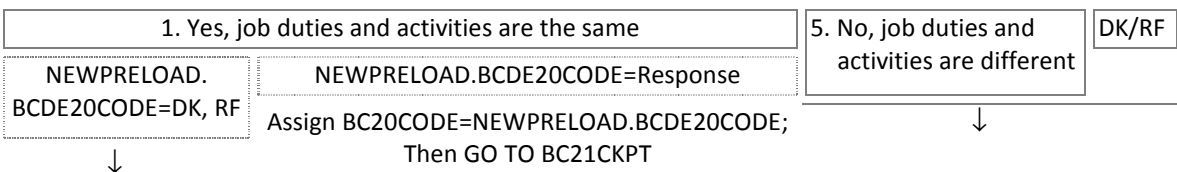

Dependent Interviewing for Reinterviews

REINT: Same CMJ & Title Not Same, or CMJ Not Same, or INEL, or PY-CY MRMJ, or PY-CY OTHER JOB

RECON, SO, RECSO: CMJ, or PY-CY MRMJ, or PY-CY OTHER JOB

BC20. [CYNAMF CYNAML]: [CYAQRTH], [CYFUHU], Age [AGEIWDATE] [(Respondent)]

EMPLOYER: [EMPNAME] ([BEGMO/BEGYR]-[ENDMO/ENDYR])

((And) the job with [EMPNAME] ([BEGMO/BEGYR]-[ENDMO/ENDYR]),...)

In [your / his / her] work for [EMPNAME] ([BEGMO/BEGYR]-[ENDMO/ENDYR]), [CMJ: what is [your / [HEAD / SP]'s] occupation? What sort of work [do you / does [he / she]] do? What are [your / his / her] most important activities or duties? / MRMJ: what was [your / [HEAD / SP]'s] occupation? What sort of work did [you / he / she] do? What were [your / his / her] most important activities or duties? / OTHER JOB: what sort of work [do you do / does [he / she] do] / did [you / he / she] do?]

- [CMJ, MRMJ: PROBE up to 3 times if needed]
- [MRMJ: If needed, PROBE for most recent occupation at this employer]
- [OTHER JOB: DO NOT PROBE]

Open End

BC21CKPT. CAI Checkpoint: Whether Same CMJ as Last Wave

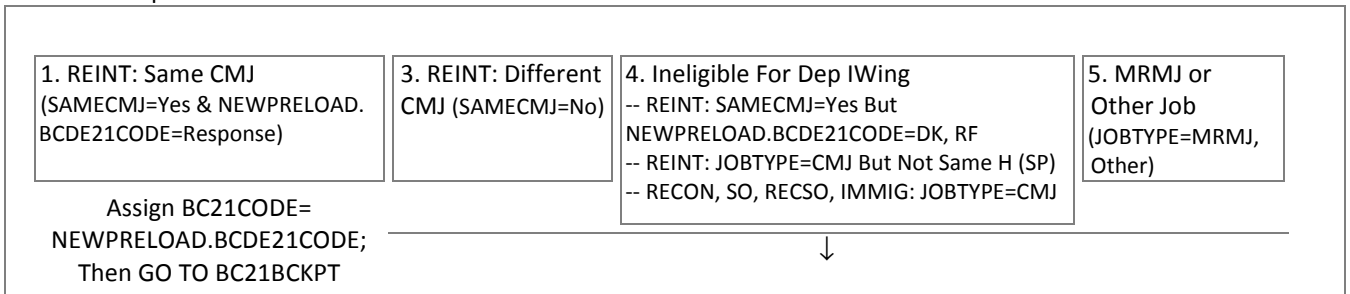

Dependent Interviewing for Reinterviews

REINT: CMJ Not Same, or INEL, or PY-CY MRMJ, or PY-CY OTHER JOB

RECON, SO, RECSO: CMJ, or PY-CY MRMJ, or PY-CY OTHER JOB

BC21. [CYNAMF CYNAML]: [CYAQRTH], [CYFUHU], Age [AGEIWDATE] [(Respondent)]

EMPLOYER: [EMPNAME] ([BEGMO/BEGYR]-[ENDMO/ENDYR])

((And) the job with [EMPNAME] ([BEGMO/BEGYR]-[ENDMO/ENDYR]),...)

What kind of business or industry [is / was] that in?

- [JOBTYP=OTHER: DO NOT PROBE]

Open End

NOTE: BC21A is found before BC20 RULE

BC21BCKPT. CAI Checkpoint: Job Type

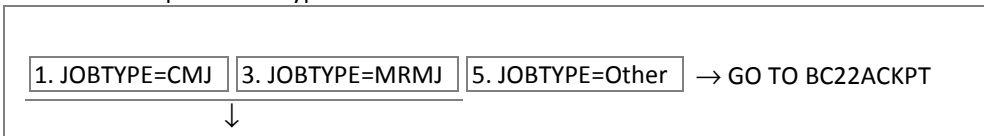

CMJ or PY-CY MRMJ

BC21B. [CYNAMF CYNAML]: [CYAQRTH], [CYFUHU], Age [AGEIWDATE] [(Respondent)]

EMPLOYER: [EMPNAME] ([BEGMO/BEGYR]-[ENDMO/ENDYR])

On a typical day, how many minutes [CMJ: is / MRMJ: was] [your / his / her] round trip commute to and from work?

- If R says "travels from home to temporary lodging near worksite", ENTER [995]
- If R says "it varies", ENTER [996]
- If R says "doesn't commute" (e.g. self-employed, works from home), ENTER [997]

| | | | |
|---------|-------------------------|----------------------|-----------------------|
| 1 – 900 | 995. Temp lodging (VOL) | 996. It varies (VOL) | 997. No commute (VOL) |
|---------|-------------------------|----------------------|-----------------------|

BC22ACKPT. CAI Checkpoint: Whether Same CMJ as Last Wave

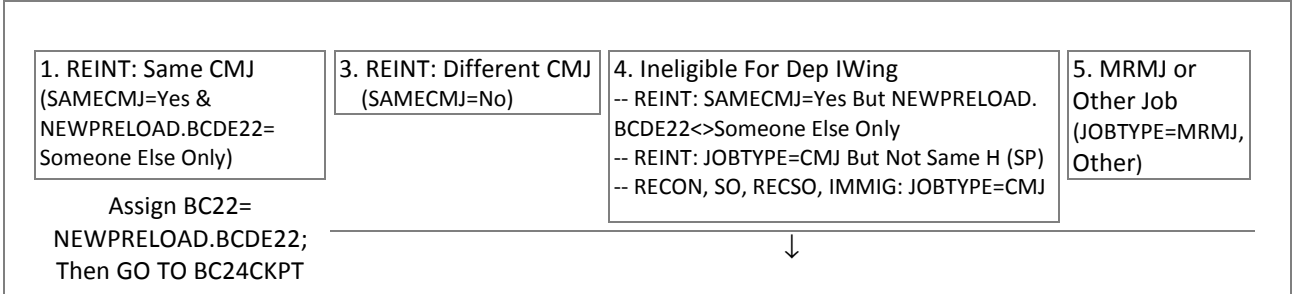

Dependent Interviewing for Reinterviews

REINT: CMJ Not Same, or INEL, or PY-CY MRMJ, or PY-CY OTHER JOB

RECON, SO, RECSO: CMJ, or PY-CY MRMJ, or PY-CY OTHER JOB

BC22. [CYNAMF CYNAML]: [CYAQRTH], [CYFUHU], Age [AGEIWDATE] [(Respondent)]

EMPLOYER: [EMPNAME] [(BEGMO/BEGYR)-[ENDMO/ENDYR)]

[[Are / Were] you] / [Is / Was] [HEAD / SP]] self-employed, [[are / were] you / [is / was] [he / she]] employed by someone else, or what?

- | | | | |
|----------------------|-------------------------------|-----------------------|-------|
| 1. Someone else only | 2. Both someone else and self | 3. Self-employed only | DK/RF |
|----------------------|-------------------------------|-----------------------|-------|

GO TO BC24CKPT



GO TO BC25ACKPT

BC23. [CYNAMF CYNAML]: [CYAQRTH], [CYFUHU], Age [AGEIWDATE] [(Respondent)]

EMPLOYER: [EMPNAME] [(BEGMO/BEGYR)-[ENDMO/ENDYR)]

[Is / Was] that an unincorporated business or a corporation?

- | | |
|-------------------|----------------|
| 1. Unincorporated | 2. Corporation |
|-------------------|----------------|

GO TO BC25ACKPT

BC24CKPT. CAI Checkpoint: Whether Same CMJ as Last Wave; Whether Works for Someone Else Only

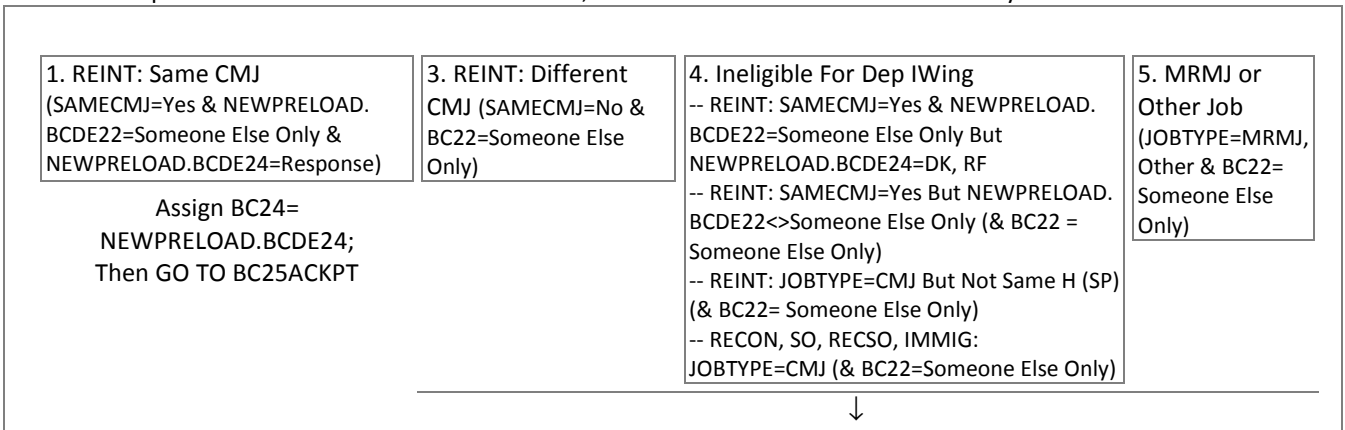

Dependent Interviewing for Reinterviews

REINT: CMJ Not Same, or INEL, or PY-CY MRMJ, or PY-CY OTHER JOB and Works for Someone Else Only

RECON, SO, RECSO: CMJ, or PY-CY MRMJ, or PY-CY OTHER JOB and Works for Someone Else Only

BC24. [CYNAMF CYNAML]: [CYAQRTH], [CYFUHU], Age [AGEIWDATE] [(Respondent)]

EMPLOYER: [EMPNAME] [(BEGMO/BEGYR)-[ENDMO/ENDYR)]

[Do you / Did [HEAD / SP]] work for the federal, state, or local government, a private company, or what?

- | | | | |
|-----------------------|---------------------|---------------------|---------------------------|
| 1. Federal government | 2. State government | 3. Local government | 4. Private non-government |
|-----------------------|---------------------|---------------------|---------------------------|

7. Other-specify (BC24SPEC. Specify. (String 100))

BC25ACKPT. CAI Checkpoint: Whether Same CMJ as Last Wave

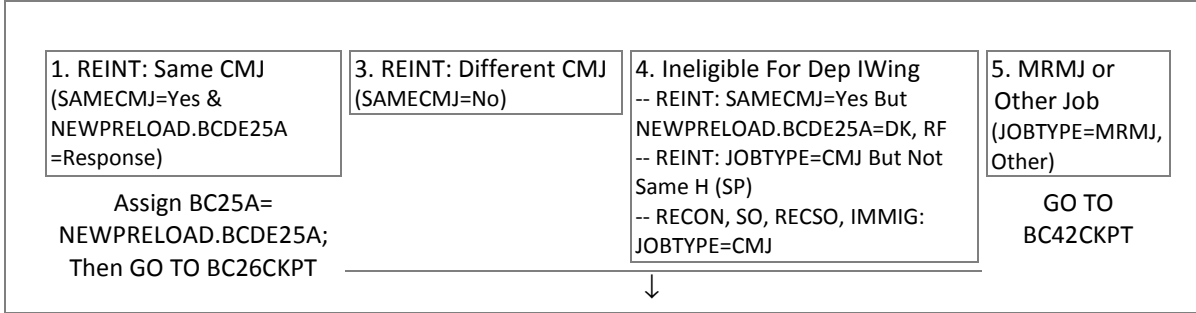

Dependent Interviewing for Reinterviews

REINT: CMJ Not Same, or INEL

RECON, SO, RECSO: CMJ

BC25A. [CYNAMF CYNAML]: [CYAQRTH], [CYFUHU], Age [AGEIWDAT] [(Respondent) EMPLOYER: [EMPNAME] [(BEGMO/BEGYR)-[ENDMO/ENDYR])

Including [yourself / [HEAD / SP]], about how many people are employed [BC22=SOMEONE ELSE ONLY: (by [[EMPNAME] [(BEGMO/BEGYR)-[ENDMO/ENDYR]])] at the location where [you work / [HEAD / SP] works]?

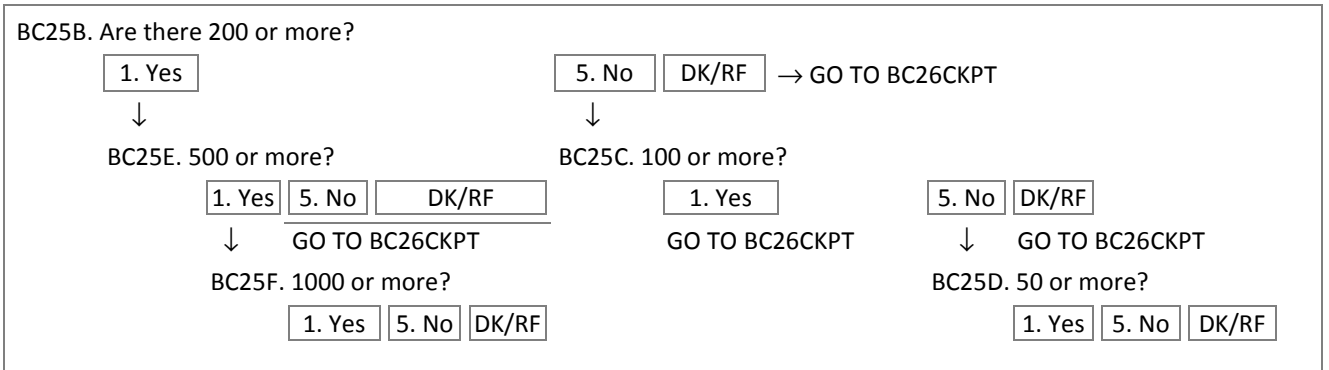
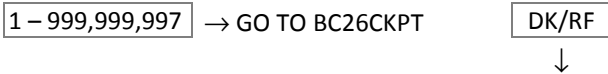

BC26CKPT. CAI Checkpoint: Whether Same CMJ as Last Wave; Whether Same Job Title as Last Wave; Whether Works for Someone Else Only

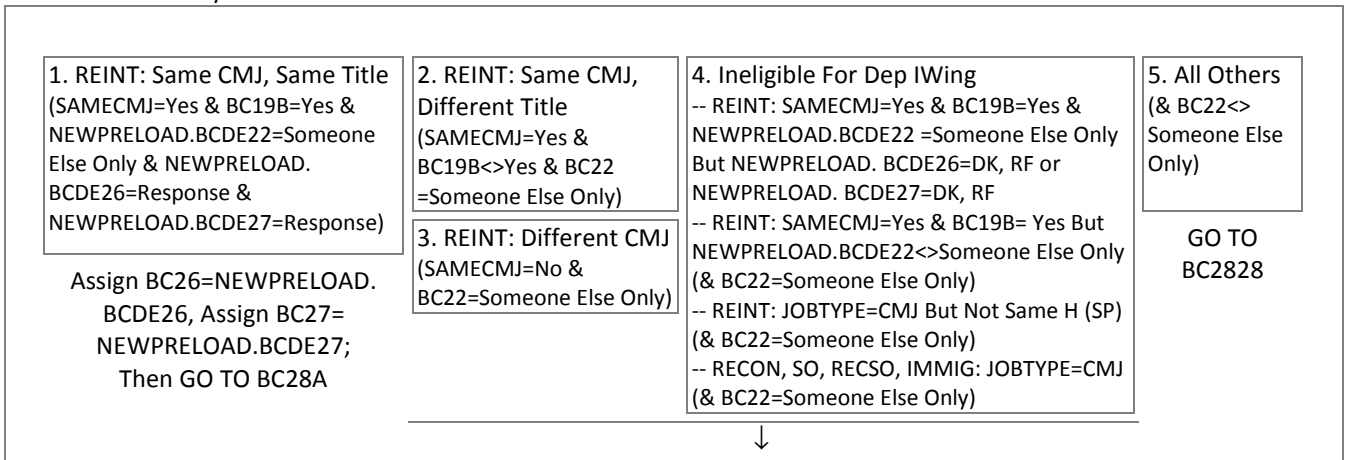

Dependent Interviewing for Reinterviews

REINT: Same CMJ & Title Not Same, or CMJ Not Same, or INEL **and** Works for Someone Else Only

RECON, SO, RECSO: CMJ **and** Works for Someone Else Only

BC26. [CYNAMF CYNAML]: [CYAQRTH], [CYFUHU], Age [AGEIWDATE]

EMPLOYER: [BC EMPNAME] ([BEGMO/BEGYR]-[ENDMO/ENDYR])

Is [your / his / her] current job covered by a union contract?

1. Yes 5. No → GO TO BC28A

↓

BC27. [CYNAMF CYNAML]: [CYAQRTH], [CYFUHU], Age [AGEIWDATE] [(Respondent)]

EMPLOYER: [EMPNAME] ([BEGMO/BEGYR]-[ENDMO/ENDYR])

[Do you / Does [HEAD / SP]] belong to that labor union?

1. Yes 5. No

GO TO BC28A

CMJ **and** Does Not Work for Someone Else Only

BC28. [CYNAMF CYNAML]: [CYAQRTH], [CYFUHU], Age [AGEIWDATE] [(Respondent)]

EMPLOYER: [EMPNAME] ([BEGMO/BEGYR]-[ENDMO/ENDYR])

Interviewer Checkpoint:

Is [HEAD / SP] a farmer or rancher?

- Ask R only if you are unclear about the answer.

1. Yes 5. No

CMJ

BC28A. [CYNAMF CYNAML]: [CYAQRTH], [CYFUHU], Age [AGEIWDATE] [(Respondent)]

EMPLOYER: [EMPNAME] ([BEGMO/BEGYR]-[ENDMO/ENDYR])

And would you say [your / his / her] work requires the use of a computer - All of the time, Most of the time, Some of the time, or None of the time?

1. All of the time 2. Most of the time 3. Some of the time 4. None of the time

BC29. [CYNAMF CYNAML]: [CYAQRTH], [CYFUHU], Age [AGEIWDATE] [(Respondent)]

EMPLOYER: [EMPNAME] ([BEGMO/BEGYR]-[ENDMO/ENDYR])

On [your / his / her] main job for [EMPNAME] ([BEGMO/BEGYR]-[ENDMO/ENDYR]), [are you / is [HEAD / SP]] salaried, paid by the hour, or what?

1. Salaried 2. Salary + commission 3. Paid by hour 4. Hourly + tips 7. Other DK/RF

GO TO BC30

6. Hourly + commission

↓

GO TO BC39A

GO TO BC33

BC38. [CYNAMF CYNAML]: [CYAQRTH], [CYFUHU], Age [AGEIWDATE] [(Respondent)]

EMPLOYER: [EMPNAME] ([BEGMO/BEGYR]-[ENDMO/ENDYR])

How is that?

1. Piecework, hourly + piecework/ production 2. Commission

5. Self-employed, farmer, "profits" - draw on account 6. By the job/day/mile

7. Other-specify (BC38SPEC. Specify (String 500))

BC39. [CYNAMF CYNAML]: [CYAQRTH], [CYFUHU], Age [AGEIWDATE] [(Respondent)]

EMPLOYER: [EMPNAME] ([BEGMO/BEGYR]-[ENDMO/ENDYR])

If [you / he / she] worked an extra hour, how much would [you / he / she] earn for that hour?

- PER hour

GO TO BC39A

CMJ - Salaried or Salary + commission

BC30. [CYNAMF CYNAML]: [CYAQRTH], [CYFUHU], Age [AGEIWDATE] [(Respondent)]

EMPLOYER: [EMPNAME] ([BEGMO/BEGYR]-[ENDMO/ENDYR])

How much is [your / his / her] salary?

- ENTER amount here, then SELECT unit of time on next screen (Week, Two weeks, Month, Year)

 → GO TO BC31

BC30PER. [CYNAMF CYNAML]: [CYAQRTH], [CYFUHU], Age [AGEIWDATE] [(Respondent)]

EMPLOYER: [EMPNAME] ([BEGMO/BEGYR]-[ENDMO/ENDYR])

- The salary amount entered is: [BC30] per ____
- SELECT the unit of time below

BC31. [CYNAMF CYNAML]: [CYAQRTH], [CYFUHU], Age [AGEIWDATE] [(Respondent)]

EMPLOYER: [EMPNAME] ([BEGMO/BEGYR]-[ENDMO/ENDYR])

If [you / he / she] were to work more hours than usual during some week, would [you / he / she] get paid for those extra hours of work?

 → GO TO BC35CKPT

BC32. [CYNAMF CYNAML]: [CYAQRTH], [CYFUHU], Age [AGEIWDATE] [(Respondent)]

EMPLOYER: [EMPNAME] ([BEGMO/BEGYR]-[ENDMO/ENDYR])

About how much would [you / he / she] make per hour for those extra hours?

- If needed: Would that be time and a half, double time, straight time, comp time or an exact amount?

GO TO BC35CKPT



BC32A. [CYNAMF CYNAML]: [CYAQRTH], [CYFUHU], Age [AGEIWDATE] [(Respondent)]

EMPLOYER: [EMPNAME] ([BEGMO/BEGYR]-[ENDMO/ENDYR])

- SPECIFY amount
- ENTER amount here, then SELECT unit of time on next screen (Hour, Day, Week, Two weeks, Month, Year)

 → GO TO BC35CKPT

BC32APER. [CYNAMF CYNAML]: [CYAQRTH], [CYFUHU], Age [AGEIWDATE] [(Respondent)]

EMPLOYER: [EMPNAME] ([BEGMO/BEGYR]-[ENDMO/ENDYR])

- The amount entered is: [BC32A] per ____
- SELECT the unit of time below

GO TO BC35CKPT

CMJ - Paid by hour or Hourly + tips or Hourly + commission

BC33. [CYNAMF CYNAML]: [CYAQRTH], [CYFUHU], Age [AGEIWDATE] [(Respondent)]

EMPLOYER: [EMPNAME] ([BEGMO/BEGYR]-[ENDMO/ENDYR])

What is [your / his / her] hourly wage rate for [your / his / her] regular work time?

- PER hour

BC34. [CYNAMF CYNAML]: [CYAQRTH], [CYFUHU], Age [AGEIWDATE] [(Respondent)]
 EMPLOYER: [EMPNAME] [(BEGMO/BEGYR)-[ENDMO/ENDYR)]

What is [your / his / her] hourly wage rate for overtime?

- ENTER all that apply
- ENTER Refusal [Ctrl-R] for “does not work overtime”, “does not get overtime pay”
- If R says “Straight time”, PROBE: Do you mean [you are / [he / she] is] paid the same rate for overtime as for regular hours?
- If R says “Comp time” or “compensation time”, PROBE: Do you mean [you receive / [he / she] receives] additional time off instead of overtime pay?

| | | | | |
|---|----------------|------------------|--------------|-------------------------|
| 1. Time and a half | 2. Double time | 3. Straight time | 4. Comp time | 5. Exact amount-specify |
| 7. Other-specify (BC34SPEC. Specify other overtime wage rate. (String 100)) | | | | ↓ |

GO TO BC35CKPT

BC34A. [CYNAMF CYNAML]: [CYAQRTH], [CYFUHU], Age [AGEIWDATE] [(Respondent)]
 EMPLOYER: [EMPNAME] [(BEGMO/BEGYR)-[ENDMO/ENDYR)]

- SPECIFY overtime exact amount
- ENTER amount here, then SELECT unit of time on next screen (Hour, Day, Week, Two weeks, Month, Year)

| | | |
|------------------------|-------|------------------|
| \$ 1.00 – 9,999,997.99 | DK/RF | → GO TO BC35CKPT |
|------------------------|-------|------------------|

↓

BC34APER. [CYNAMF CYNAML]: [CYAQRTH], [CYFUHU], Age [AGEIWDATE] [(Respondent)]
 EMPLOYER: [EMPNAME] [(BEGMO/BEGYR)-[ENDMO/ENDYR)]

- The amount entered is: [BC34A] per ____
- SELECT the unit of time below

| | | | | | |
|--|--------|---------|--------------|----------|---------|
| 1. Hour | 2. Day | 3. Week | 4. Two Weeks | 5. Month | 6. Year |
| 7. Other-specify (BC34APERSPEC. Specify. (String 100)) | | | | | |

BC35CKPT. CAI Checkpoint: Whether Receives Tips or Commissions

| | | | |
|------------------|----------------------------|---------------|-------------------|
| 1. Tips (BC29=4) | 2. Commissions (BC29=2, 6) | 5. All Others | → GO TO BC39ACKPT |
| ↓ | ↓ | | |

BC36. [CYNAMF CYNAML]: [CYAQRTH], [CYFUHU], Age [AGEIWDATE] [(Respondent)]
 EMPLOYER: [EMPNAME] [(BEGMO/BEGYR)-[ENDMO/ENDYR)]
 How much are [your / his / her] tips, on average?

- ENTER amount here, then SELECT unit of time on next screen (Hour, Day, Week, Two weeks, Month, Year)

| | | |
|---------------------|-------|-------------------|
| \$ 1.00 – 99,997.99 | DK/RF | → GO TO BC39ACKPT |
|---------------------|-------|-------------------|

↓

BC36PER. [CYNAMF CYNAML]: [CYAQRTH], [CYFUHU], Age [AGEIWDATE] [(Respondent)]
 EMPLOYER: [EMPNAME] [(BEGMO/BEGYR)-[ENDMO/ENDYR)]
 The amount entered is: [BC36] per _

- SELECT the unit of time below

| | | |
|---|----------|---------|
| 1. Hour | 2. Day | 3. Week |
| 4. Two Weeks | 5. Month | 6. Year |
| 7. Other-specify (BC36PERSPEC. Specify. (String 100)) | | |

BC37. [CYNAMF CYNAML]: [CYAQRTH], [CYFUHU], Age [AGEIWDATE] [(Respondent)]
 EMPLOYER: [EMPNAME] [(BEGMO/BEGYR)-[ENDMO/ENDYR)]
 How much is [your / his / her] commission on average?

- ENTER amount here, then SELECT unit of time on next screen (Week, Two weeks, Month, Year)

| | | |
|------------------|-------|-------------------|
| \$ 1 – 9,999,997 | DK/RF | → GO TO BC39ACKPT |
|------------------|-------|-------------------|

↓

BC37PER. [CYNAMF CYNAML]: [CYAQRTH], [CYFUHU], Age [AGEIWDATE] [(Respondent)]
 EMPLOYER: [EMPNAME] [(BEGMO/BEGYR)-[ENDMO/ENDYR)]
 The amount entered is: [BC37] per _

- SELECT the unit of time below

| | | | |
|--|--------------|----------|---------|
| 3. Week | 4. Two Weeks | 5. Month | 6. Year |
| 7. Other-specify (BC37ERSPEC. Specify. (String 100)) | | | |

BC39ACKPT. CAI Checkpoint: Number of Current Jobs

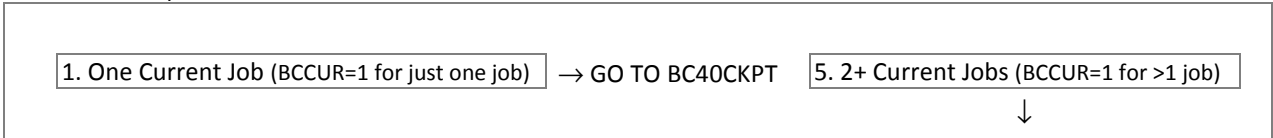

CMJ - Hours Per Week Worked

BC39A. [CYNAMF CYNAML]: [CYAQRTH], [CYFUHU], Age [AGEIWDATE] [(Respondent)]
 EMPLOYER: [EMPNAME] [(BEGMO/BEGYR)-[ENDMO/ENDYR)]

On average, how many hours a week do you / does [HEAD / SP]] currently work on this job?

- ROUND DOWN for fractions less than ½ (0.5)
- ROUND UP for fractions ½ (0.5) or more

1 - 112

BC40CKPT. CAI Checkpoint: Whether Same CMJ as Last Wave; Whether Works for Someone Else Only

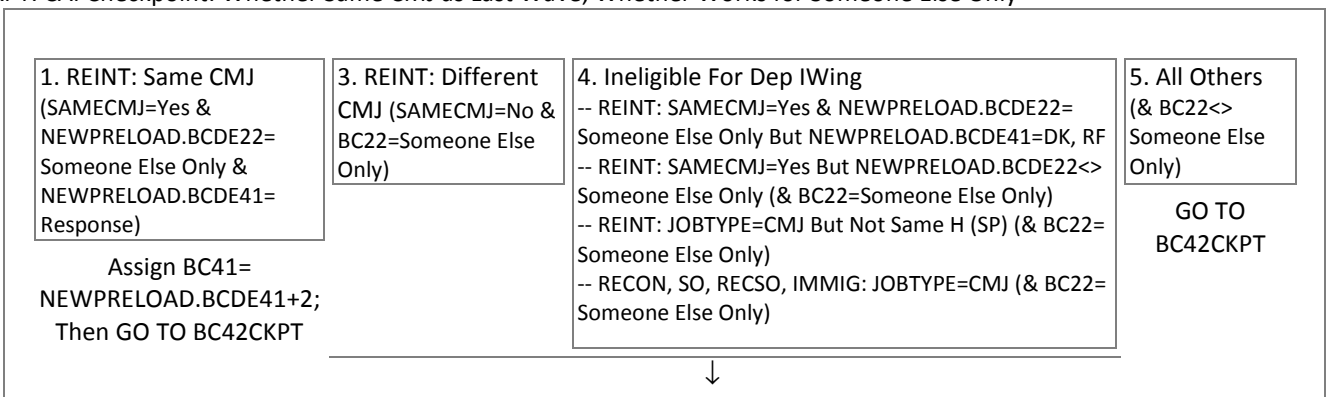

Dependent Interviewing for Reinterviews

REINT: CMJ Not Same, or INEL, **and** Works for Someone Else Only

RECON, SO, RECSO: CMJ **and** Works for Someone Else Only

BC41. [CYNAMF CYNAML]: [CYAQRTH], [CYFUHU], Age [AGEIWDATE] [(Respondent)]
 EMPLOYER: [EMPNAME] [(BEGMO/BEGYR)-[ENDMO/ENDYR)]

How many years' experience [do you / does [HEAD / SP]] have altogether with [your / his / her] present employer?

- USE Years for amounts given in whole years
- USE Months and Weeks for amounts less than one year
- USE 1 week for amounts of one week or less

BC41.YEARS 1 – 65

BC41.MONTHS 1 – 12

BC41.WEEKS 1 – 52

BC42CKPT. CAI Checkpoint: Whether Worked Job in PYEAR; Whether PYEAR Weeks or Hours/Week Can Be Computed

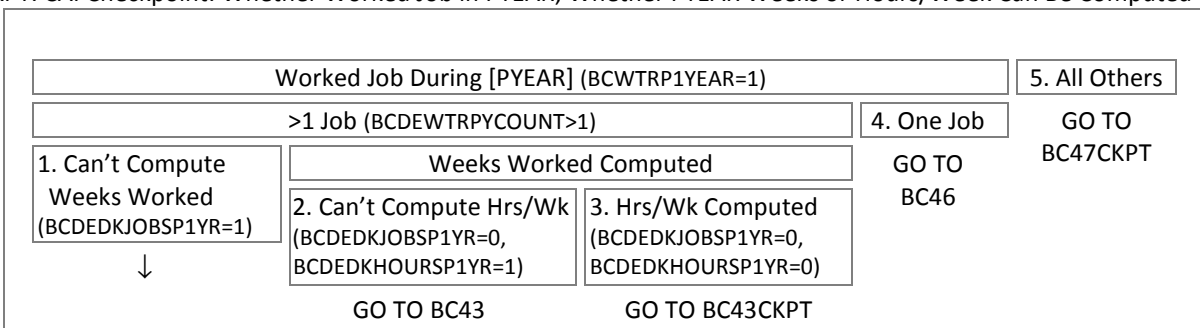

Pyear JOB and EmployEHC1.BCDEDkJobsP1Yr=1

BC42A. [CYNAMF CYNAML]: [CYAQRTH], [CYFUHU], Age [AGEIWDATE] [(Respondent)]
EMPLOYER: [EMPNAME] ([BEGMO/BEGYR]-[ENDMO/ENDYR])

((And) the job with [EMPNAME] ([BEGMO/BEGYR]-[ENDMO/ENDYR]),...)

How many weeks out of the year did [you / [HEAD / SP]] actually work on this job in [PYEAR], not including any time off that you told me about earlier?

- IF R says "Every week except what (I / he / she) took off", ENTER [97]

*BC42A data used to calculate 'total weeks worked' and not included in public use data

BC43CKPT. CAI Checkpoint: Whether PYEAR Hours/Week Can Be Computed

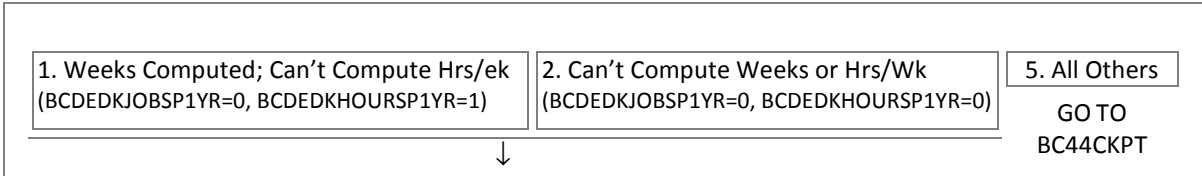

PY JOB and EmployEHC1.BCDEDkJobsP1Yr=1

BC43. [CYNAMF CYNAML]: [CYAQRTH], [CYFUHU], Age [AGEIWDATE] [(Respondent)]
EMPLOYER: [EMPNAME] ([BEGMO/BEGYR]-[ENDMO/ENDYR])

((And) the job with [EMPNAME] ([BEGMO/BEGYR]-[ENDMO/ENDYR]),...)

On average, how many hours a week did [you / he / she] work on this job in [PYEAR]?

- ROUND DOWN for fractions less than ½ (0.5)
- ROUND UP for fractions ½ (0.5) or more

BC44CKPT. CAI Checkpoint: Whether PYEAR Overtime Can Be Computed

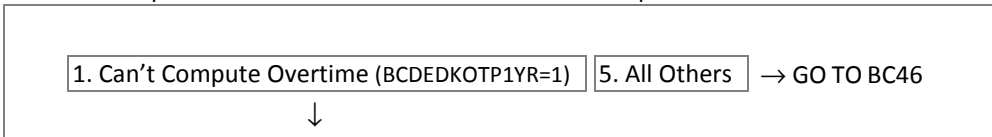

PY JOB and EmployEHC1.BCDEDkJobsP1Yr=1

BC44. [CYNAMF CYNAML]: [CYAQRTH], [CYFUHU], Age [AGEIWDATE] [(Respondent)]
EMPLOYER: [EMPNAME] ([BEGMO/BEGYR]-[ENDMO/ENDYR])

((And) the job with [EMPNAME] ([BEGMO/BEGYR]-[ENDMO/ENDYR]),...)

Did [you / he / she] work any overtime [HRS/WK COMPUTED BUT OT NOT COMPUTED: (on this job in [PYEAR]) / HRS/WK & OT NOT COMPUTED: which isn't included in that]?

→ GO TO BC46

↓

BC45. [CYNAMF CYNAML]: [CYAQRTH], [CYFUHU], Age [AGEIWDATE] [(Respondent)]
EMPLOYER: [EMPNAME] ([BEGMO/BEGYR]-[ENDMO/ENDYR])

How many hours did that overtime amount to in (that period during) [PYEAR]?

- ENTER amount here, then SELECT unit of time on next screen (Week, Two weeks, Month, Year)
- ROUND DOWN for fractions less than ½ (0.5)
- ROUND UP for fractions ½ (0.5) or more

→ GO TO BC46

↓

BC45PER. [CYNAMF CYNAML]: [CYAQRTH], [CYFUHU], Age [AGEIWDTE] [(Respondent)]
 EMPLOYER: [EMPNAME] ([BEGMO/BEGYR]-[ENDMO/ENDYR])

- The amount entered is: [BC45] per ____
- SELECT the unit of time below

| | | | |
|---|--------------|----------|---------|
| 3. Week | 4. Two weeks | 5. Month | 6. Year |
| 7. Other-specify (BC45PERSPEC. Specify. (String 100)) | | | |

PY Job

BC46. [CYNAMF CYNAML]: [CYAQRTH], [CYFUHU], Age [AGEIWDTE] [(Respondent)]
 EMPLOYER: [EMPNAME] ([BEGMO/BEGYR]-[ENDMO/ENDYR])
 ((And) the job with [EMPNAME] ([BEGMO/BEGYR]-[ENDMO/ENDYR]),...)
 About how much did [you / he / she] make at this job in [PYEAR]?

- ENTER amount here, then SELECT unit of time on next screen (Hour, Day, Week, Two weeks, Month, Year)

\$ 1.0 – 9,999,997.99 DK/RF → GO TO BC47CKPT



BC46PER. [CYNAMF CYNAML]: [CYAQRTH], [CYFUHU], Age [AGEIWDTE] [(Respondent)]
 EMPLOYER: [EMPNAME] ([BEGMO/BEGYR]-[ENDMO/ENDYR])

- The amount entered is: [BC46] per ____
- SELECT the unit of time below

| | | | | | |
|---|--------|---------|--------------|----------|---------|
| 1. Hour | 2. Day | 3. Week | 4. Two Weeks | 5. Month | 6. Year |
| 7. Other-specify (BC46PERSPEC. Specify. (String 100)) | | | | | |

BC47CKPT. CAI Checkpoint: Whether Worked Job in P2YEAR; Whether P2YEAR Weeks or Hours/Week Can Be Computed

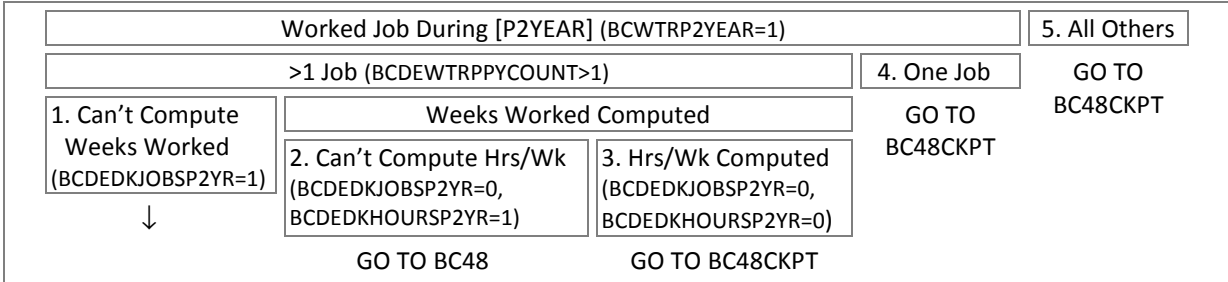

P2Y Job and EmployEHC1.BCDEDkJobsP2Yr=1

BC47A. [CYNAMF CYNAML]: [CYAQRTH], [CYFUHU], Age [AGEIWDTE] [(Respondent)]
 EMPLOYER: [EMPNAME] ([BEGMO/BEGYR]-[ENDMO/ENDYR])
 ((And) the job with [EMPNAME] ([BEGMO/BEGYR]-[ENDMO/ENDYR]),...)
 How many weeks out of the year did [you / [HEAD / SP]] actually work on this job in [P2YEAR]?

- IF R says "Every week except what (I / he / she) took off", ENTER [97]

1.0 – 52.0 97.0

BC48CKPT. CAI Checkpoint: Whether P2YEAR Hours/Week Can Be Computed

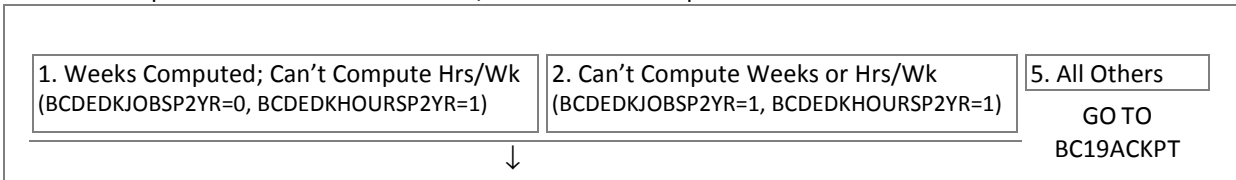

P2Y Job **and** EmployEHC1.BCDEDkJobsP2Yr=1

BC48. [CYNAMF CYNAML]: [CYAQRTH], [CYFUHU], Age [AGEIWDATE] [(Respondent)]
EMPLOYER: [EMPNAME] ([BEGMO/BEGYR]-[ENDMO/ENDYR])

((And) the job with [EMPNAME] ([BEGMO/BEGYR]-[ENDMO/ENDYR]),...)

On average, how many hours a week did [you / he / she] work on this job in [P2YEAR] ?

- ROUND DOWN for fractions less than ½ (0.5)
- ROUND UP for fractions ½ (0.5) or more

1 – 112

BC19ACKPT. CAI Checkpoint: Whether Same CMJ as Last Wave; Whether CMJ, or MRMJ Worked in PYEAR-CYEAR; Whether Works for Someone Else Only

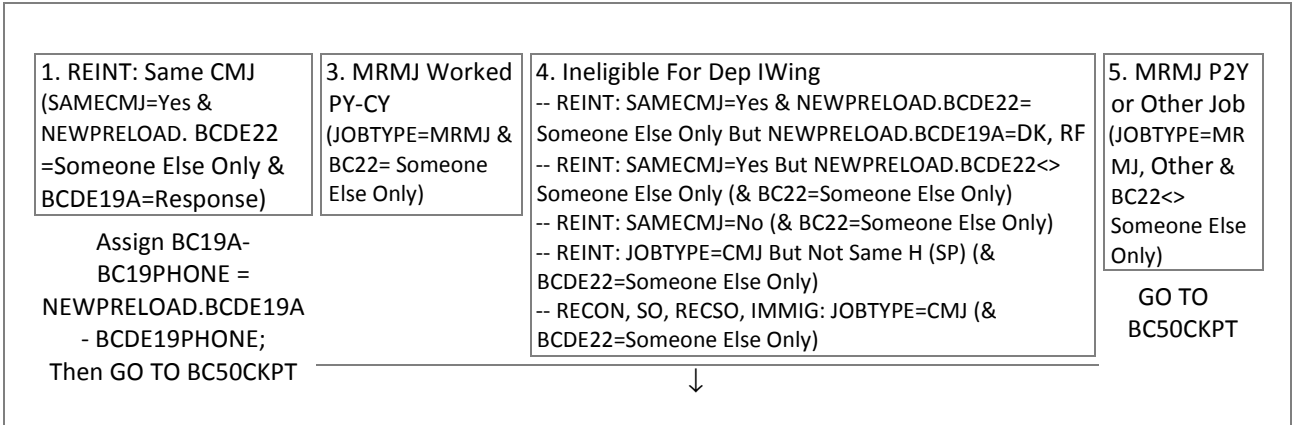

Dependent Interviewing for Reinterviews

REINT: CMJ Not Same, or INEL, **and** Works for Someone Else Only

RECON, SO, RECSO: CMJ, or PY-CY MRMJ, **and** Works for Someone Else Only

BC19A. [CYNAMF CYNAML]: [CYAQRTH], [CYFUHU], Age [AGEIWDATE] [(Respondent)]
EMPLOYER: [EMPNAME] ([BEGMO/BEGYR]-[ENDMO/ENDYR])

[1st ITERATION: We would like to obtain information about characteristics of employers of our study members, such as benefits offered to employees. In order to do this, we need the full address of the place where [you work / [HEAD / SP] works] for [EMPNAME].

As you know, the information we collect is confidential, and that includes maintaining confidentiality in collecting information about employers. / 2nd ITERATION: As we mentioned earlier, we would like to obtain information about employer characteristics, such as benefits offered to employees.

In order to do this, we need the full address of the place where [you work / [SP]] works] for [EMPNAME].

- If needed: We would use the employer address to collect general information about [your / her] employer, such as number of workers or benefits offered to employees.]
- If needed: The information we collect is confidential, and that includes maintaining confidentiality in collecting information about employers.
- If R knows just part of the address, ENTER [1]
- If R knows none of the address, ENTER [Ctrl-D]

1. Continue | DK/RF → GO TO BC50CKPT



BC19ADDR1. [CYNAMF CYNAML]: [CYAQRTH], [CYFUHU], Age [AGEIWDATE] [(Respondent)]
EMPLOYER: [EMPNAME] ([BEGMO/BEGYR]-[ENDMO/ENDYR])

What is the mailing address?

Address 1

- Enter street address here
- Enter PO Box at next screen
- Ctrl-D and Ctrl-R not allowed; For DK/RF, type [DK] or [REF]

String 40

BC19ADDR2. [CYNAMF CYNAML]: [CYAQRTH], [CYFUHU], Age [AGEIWDATE] [(Respondent)]
 EMPLOYER: [EMPNAME] [(BEGMO/BEGYR)-[ENDMO/ENDYR])
 Address 2

- Enter PO Box here
- If none, PRESS [Enter] to continue.
- Ctrl-D and Ctrl-R not allowed; For DK/RF, PRESS [Enter]

String 40

BC19CITY. [CYNAMF CYNAML]: [CYAQRTH], [CYFUHU], Age [AGEIWDATE] [(Respondent)]
 EMPLOYER: [EMPNAME] [(BEGMO/BEGYR)-[ENDMO/ENDYR])
 City

- Ctrl-D and Ctrl-R not allowed; For DK/RF, type [DK] or [REF]

String 40

BC19STATE. [CYNAMF CYNAML]: [CYAQRTH], [CYFUHU], Age [AGEIWDATE] [(Respondent)]
 EMPLOYER: [EmpName] [(BegMo/BegYr)-[EndMo/EndYr])
 State

- Start typing the name of the State to bring up the look-up list
- If foreign country, ENTER [FOR] to select "Foreign Country"

String 30; U.S. State

Foreign Country DK/RF → GO TO BC19PHONE



BC19ZIP. [CYNAMF CYNAML]: [CYAQRTH], [CYFUHU], Age [AGEIWDATE] [(Respondent)]
 EMPLOYER: [EMPNAME] [(BEGMO/BEGYR)-[ENDMO/ENDYR])
 Zip Code

- If foreign country, ENTER all [0]'s
- Ctrl-D and Ctrl-R not allowed; For DK/RF, ENTER all [0]'s

_____ - _____

BC19CNTRY. [CYNAMF CYNAML]: [CYAQRTH], [CYFUHU], Age [AGEIWDATE] [(Respondent)]
 EMPLOYER: [EMPNAME] [(BEGMO/BEGYR)-[ENDMO/ENDYR])
 Country if different from USA

- Start typing the name of the Foreign Country to bring up the look-up list

String 30; Country

BC19PHONE. [CYNAMF CYNAML]: [CYAQRTH], [CYFUHU], Age [AGEIWDATE] [(Respondent)]
 EMPLOYER: [EMPNAME] [(BEGMO/BEGYR)-[ENDMO/ENDYR])
 (And) the area code and phone number?

- Area Code and Telephone Number
- If foreign phone, ENTER all [0]'s
- Ctrl-D and Ctrl-R not allowed; For DK/RF ENTER all [0]'s

(____)____-_____

BC50CKPT. CAI Checkpoint: Whether Job Ended in P2YEAR-CYEAR

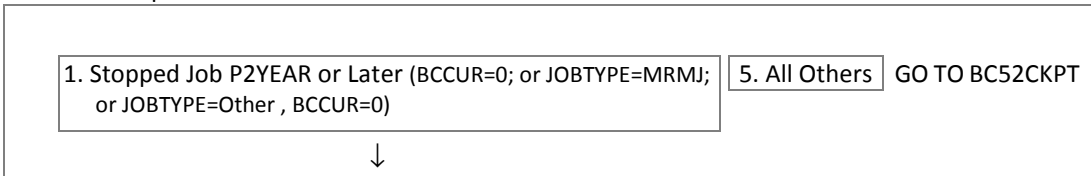

Job Ended P2Y-CY

BC51. [CYNAMF CYNAML]: [CYAQRTH], [CYFUHU], Age [AGEIWDATE] [(Respondent)]

EMPLOYER: [EMPNAME] ([BEGMO/BEGYR]-[ENDMO/ENDYR])

((And) the job with [EMPNAME] ([BEGMO/BEGYR]-[ENDMO/ENDYR]),...)

Why did [you / he / she] stop working for [EMPNAME] ([BEGMO/BEGYR]-[ENDMO/ENDYR])? Did the company go out of business, [were you / was [he / she]] laid off, did [you / he / she] quit, or what?

BC52CKPT. CAI Checkpoint: Whether More Jobs in EHC

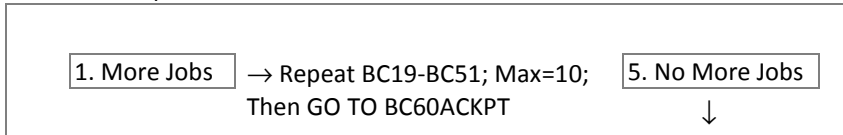
**END BCJOBS**Time Use at Work

BC60ACKPT. CAI Checkpoint: Whether Head (Spouse/Partner) is Currently Working

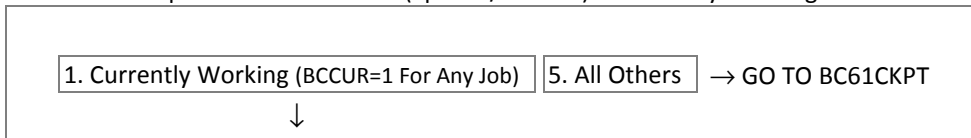

BC60A. [CYNAMF CYNAML]: [CYAQRTH], [CYFUHU], Age [AGEIWDATE] [(Respondent)]

Current Employers:[List of Current Employers]These next questions are about the time [you spend / [HEAD / SP] spends] working in a typical week.

In a typical week, how many hours [do you / does [he /she]] spend working for pay?

- IF R report hours other than weekly, PROBE: About how many hours per week would you say that is?
- IF R reports a range, PROBE: Within that range, what is your best estimate?
- ROUND DOWN for fractions less than ½ (0.5)
- ROUND UP for fractions ½ (0.5) or more

0 None

1-111 Actual hours

112 112 Hours or more

BC60B. [CYNAMF CYNAML]: [CYAQRTH], [CYFUHU], Age [AGEIWDATE] [(Respondent)]

Current Employers:[List of Current Employers]While [you are / he is / she is] working, how often [do you / does [he /she]] interact with other people, including on the phone, in person, and online? Would you say never, rarely, sometimes, often, or almost always?

BC60C. [CYNAMF CYNAML]: [CYAQRTH], [CYFUHU], Age [AGEIWDATE] [(Respondent)]

Current Employers:[List of Current Employers]While [you are / he is / she is] working, how often [do you / does [he /she]] perform physically demanding activities, for example, those that require strength or physical effort for long periods of time? Would you say never, rarely, sometimes, often, or almost always?

BC60D. [CYNAMF CYNAML]: [CYAQRTH], [CYFUHU], Age [AGEIWDATE] [(Respondent)]

Current Employers:

[List of Current Employers]

While [you are / he is / she is] working, how often [do you / does [he /she]] perform mentally demanding activities, for example, analyzing information, learning new material, or solving complex problems? Would you say never, rarely, sometimes, often, or almost always?

1. Never 2. Rarely 3. Sometimes 4. Often 5. Almost always or Always

BC60E. [CYNAMF CYNAML]: [CYAQRTH], [CYFUHU], Age [AGEIWDATE] [(Respondent)]

Current Employers:

[List of Current Employers]

While [you are / he is / she is] working, how often [do you / does [he /she]] feel rushed or pressed for time? Would you say never, rarely, sometimes, often, or almost always?

1. Never 2. Rarely 3. Sometimes 4. Often 5. Almost always or Always

BC61CKPT. CAI Checkpoint: Whether Did Not Work At All since 1/1/P2YEAR

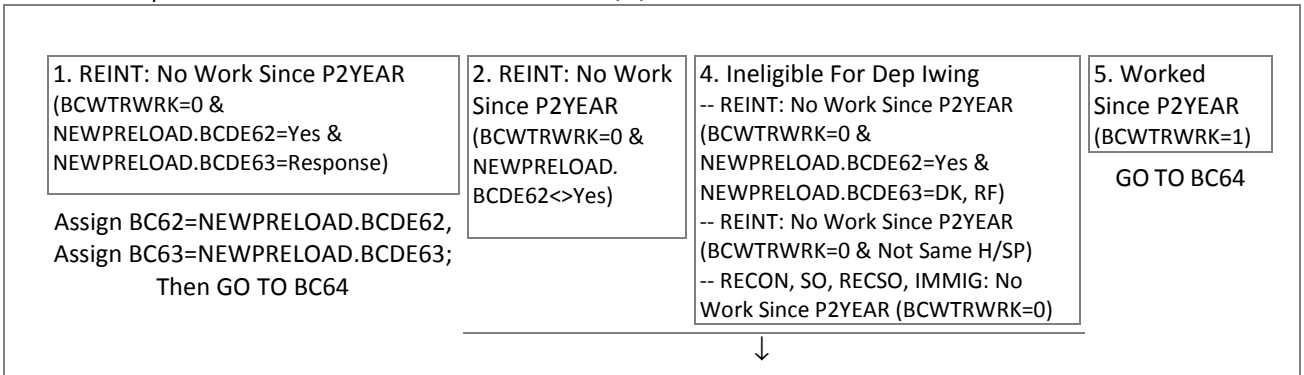

Dependent Interviewing for Reinterviews

BC62. [CYNAMF CYNAML]: [CYAQRTH], [CYFUHU], Age [AGEIWDATE] [(Respondent)]

[Have you / Has [HEAD / SP]] ever done any work for money?

1. Yes 5. No → GO TO BC64



BC63.MONTH. [CYNAMF CYNAML]: [CYAQRTH], [CYFUHU], Age [AGEIWDATE] [(Respondent)]

In what month and year did [you / he / she] last work?

- SELECT Month and [Enter] to go to next screen for year
- IF NECESSARY: What would be your best estimate?

- | | | | | | |
|------------|-------------|--------------|-------------|--------------|--------------|
| 1. January | 2. February | 3. March | 4. April | 5. May | 6. June |
| 7. July | 8. August | 9. September | 10. October | 11. November | 12. December |
| 21. Winter | 22. Spring | 23. Summer | 24. Fall | | |

BC63.YEAR. [CYNAMF CYNAML]: [CYAQRTH], [CYFUHU], Age [AGEIWDATE] [(Respondent)]

(In what month and year did [you / he / she] last work?)

[BC63.MONTH], _____

- ENTER Year
- ENTER [9997] if before [P2YEAR] and DK exact year

- | | |
|-----------------|---------------------------------------|
| 1901 – [P3YEAR] | 9997. Before [P2YEAR] , DK Exact Year |
|-----------------|---------------------------------------|

BC64. [CYNAMF CYNAML]: [CYAQRTH], [CYFUHU], Age [AGEIWDATE] [(Respondent)]

[Have you / Has [HEAD / SP] been looking for [BCDE1=WORKING, LAID OFF or BCDE3=WORKING NOW: another job / ALL OTHERS: work] during the past four weeks?

1. Yes 5. No → GO TO SECTION F



BC65. [CYNAMF CYNAML]: [CYAQRTH], [CYFUHU], Age [AGEIWDATE] [(Respondent)]

What [have you / has [he / she]] been doing the last four weeks to find [another job / work]?

- IF R SAYS "Internet, website, on-line, on the computer" etc., PROBE for specific activity: What did [you / [HEAD / SP]] do - did [you / [HEAD / SP]] contact employers or agencies, check out potential employers without applying, or what?
- ENTER all that apply
- PROBE: Any others?

| | |
|--|---|
| 1. Checked with public employment agency | 2. Checked with private employment agency |
| 3. Checked with current employer directly | 4. Checked with other employer directly |
| 5. Checked with friends or relatives | 6. Placed or answered ads |
| 7. Other-specify (BC65SPEC. Specify. (String 100)) | 8. Nothing |
| 9. Contacted school/university employment center | 10. Checked union/professional registers |
| 11. Sent out resumes/filled out applications | 12. Attended job training programs/courses |
| 13. Went on job interviews | 14. Looked at ads or employers without applying |
| 15. Used social media, e.g. Facebook, LinkedIn | |

BC65ACKPT. CAI Checkpoint: Methods Used to Look for Work

1. Nothing, or Social Media Only, or Non-Response
(BC65=8, 15 ONLY, DK/RF)

→ GO TO BC66CKPT

5. All Others



BC65A. [CYNAMF CYNAML]: [CYAQRTH], [CYFUHU], Age [AGEIWDATE] [(Respondent)]

[Methods Reported](#)

[\[List of BC65 Selections\]](#)

ASK or CONFIRM: When [you / he / she] searched, did [you / he / she] use the Internet (such as sending email or visiting websites)?

- If needed: Did [you / he / she] use the internet for any of the methods you mentioned?
- If needed: We're talking about the last 4 weeks

1. Yes 5. No → GO TO BC66CKPT



BC65B. [CYNAMF CYNAML]: [CYAQRTH], [CYFUHU], Age [AGEIWDATE] [(Respondent)]

[Methods Reported](#)

[\[List of BC65 Selections\]](#)

[Were you / Was [he / she]] required to use the internet, or were other options available (such as visiting, calling, or mailing materials)?

- ENTER [1] if R says the internet was required for some but not others
- If needed: We're talking about the last 4 weeks

1. Yes, required to use the internet 5. No, other options were available

BC66CKPT. CAI Checkpoint: Whether Head (Spouse/Partner) Has a CMJ

| | | |
|------------------------------|---------------|---------------------|
| 1. No CMJ (BC15CKPT=3, 4, 5) | 5. All Others | → GO TO BC END RULE |
| ↓ | | |

BC67. [CYNAMF CYNAML]: [CQAQRTH], [CYFUHU], Age [AGEIWDAT] [(Respondent)]

How long [have you / has [he / she]] been looking for work?

BC67.YEARS

BC67.MONTHS

BC67.WEEKS

BC END Rule. Whether Spouse/Partner in FU

| | | |
|--|--|--|
| <input type="text" value="Spouse/Partner (CQAQRTH=201-222, CYFUHU=FU, FUMI)"/> | → Repeat BCDE1-BC67; Then GO TO SECTION F | <input type="text" value="No Spouse/Partner"/> |
| ↓ | | |

END SECTION_BC

Section F: Expenditures

[TOC](#)

SECTION_F

F1. Now I have a few questions about housework and food costs. [*R=HEAD, SP, OFUM*: For these questions, when I refer to “family”, I mean your family living there with you.]

- ENTER [1] to continue

1. Continue

F1ACKPT. CAI Checkpoint: Whether Single Head or Head and Spouse/Partner in FU

| | |
|---|---|
| 1. Male Head and Spouse/Partner (CYAQRTH=101, CYFUHU=FU, FUMI and CYAQRTH=201-222, CYFUHU=FU, FUMI) | 2. Male Head and No Spouse/Partner (CYAQRTH=101, CYFUHU=FU, FUMI) |
| 3. Female Head and No Spouse/Partner (CYAQRTH=102, CYFUHU=FU, FUMI) | 4. Female Head and Spouse/Partner (CYAQRTH=102, CYFUHU=FU, FUMI and CYAQRTH=201-222, CYFUHU=FU, FUMI) |

SECTION_F.F1A_F1K[1-2] [1]=Current Head, [2]=Current Spouse/Partner

AQSN. AQSN of Current Head (Spouse/Partner)

F1A. (F2, F3) [CYNAMF CYNAML]: [CYAQRTH], [CYFUHU], Age [AGEIWDATE] [(Respondent)]

These next few questions are about how [you spend/ [HEAD] spends / [SP spends]] [your / his / her] time [*CURRENTLY WORKING*: when [you are / he is /she is] not working].

In a typical week, how many hours [do you / does [he / she]] spend doing housework, for example, cooking, cleaning, and other work around the house?

- IF R report hours other than weekly, PROBE: About how many hours per week would you say that is?
- IF R reports a range, PROBE: Within that range, what is your best estimate?
- ROUND DOWN for fractions less than ½ (0.5)
- ROUND UP for fractions ½ (0.5) or more

0 None

1-111 Actual hours

112 112 Hours or more

0-112

F1B. [CYNAMF CYNAML]: [CYAQRTH], [CYFUHU], Age [AGEIWDATE] [(Respondent)]

(In a typical week, how many hours [do you / does [he / she]] spend)

Doing personal care activities, for example, grooming, getting ready for the day, or taking care of [your / his / her] health needs?

- IF R report hours other than weekly, PROBE: About how many hours per week would you say that is?
- IF R reports a range, PROBE: Within that range, what is your best estimate?
- ROUND DOWN for fractions less than ½ (0.5)
- ROUND UP for fractions ½ (0.5) or more

0 None

1-111 Actual hours

112 112 Hours or more

0-112

F1C. [CYNAMF CYNAML]: [CYAQRTH], [CYFUHU], Age [AGEIWDATE] [(Respondent)]

(In a typical week, how many hours [do you / does [he / she]] spend)

Shopping, for example, buying groceries or clothes, or shopping online?

- IF R report hours other than weekly, PROBE: About how many hours per week would you say that is?
- IF R reports a range, PROBE: Within that range, what is your best estimate?
- ROUND DOWN for fractions less than $\frac{1}{2}$ (0.5)
- ROUND UP for fractions $\frac{1}{2}$ (0.5) or more

0 None

1-111 Actual hours

112 112 Hours or more

0-112

F1D. [CYNAMF CYNAML]: [CYAQRTH], [CYFUHU], Age [AGEIWDATE] [(Respondent)]

(In a typical week, how many hours [do you / does [he / she]] spend)

Caring for or looking after children? [*CURRENTLY WORKING*: Exclude hours providing care if this is [your / his / her] job.]

- IF R reports 24/7, ENTER [168]
- IF R report hours other than weekly, PROBE: About how many hours per week would you say that is?
- IF R reports a range, PROBE: Within that range, what is your best estimate?
- ROUND DOWN for fractions less than $\frac{1}{2}$ (0.5)
- ROUND UP for fractions $\frac{1}{2}$ (0.5) or more

0 None

1-168 Actual hours

0-168

F1D2. [CYNAMF CYNAML]: [CYAQRTH], [CYFUHU], Age [AGEIWDATE] [(Respondent)]

(In a typical week, how many hours [do you / does [he / she]] spend)

Caring for or looking after an adult who needs assistance with daily activities? [*CURRENTLY WORKING*: Exclude hours providing care if this is [your / his / her] job.]

- IF R reports 24/7, ENTER [168]
- IF R report hours other than weekly, PROBE: About how many hours per week would you say that is?
- IF R reports a range, PROBE: Within that range, what is your best estimate?
- ROUND DOWN for fractions less than $\frac{1}{2}$ (0.5)
- ROUND UP for fractions $\frac{1}{2}$ (0.5) or more

0 None

1-168 Actual hours

0-168

F1E. [CYNAMF CYNAML]: [CYAQRTH], [CYFUHU], Age [AGEIWDATE] [(Respondent)]

(In a typical week, how many hours [do you / does [he / she]] spend)

Volunteering, for example, at religious organizations, schools, hospitals, charities, or community organizations?

- IF R report hours other than weekly, PROBE: About how many hours per week would you say that is?
- IF R reports a range, PROBE: Within that range, what is your best estimate?
- ROUND DOWN for fractions less than $\frac{1}{2}$ (0.5)
- ROUND UP for fractions $\frac{1}{2}$ (0.5) or more

0 None

1-111 Actual hours

112 112 Hours or more

0-112

F1F. [CYNAMF CYNAML]: [CYAQRTH], [CYFUHU], Age [AGEIWDATE] [(Respondent)]

(In a typical week, how many hours [do you / does [he / she]] spend)

Doing educational activities, for example, taking classes, doing homework, or studying for exams? [*>1 FU MEMBER*: Exclude time spent helping others with homework.]

- IF R report hours other than weekly, PROBE: About how many hours per week would you say that is?
- IF R reports a range, PROBE: Within that range, what is your best estimate?
- ROUND DOWN for fractions less than ½ (0.5)
- ROUND UP for fractions ½ (0.5) or more

0 None

1-111 Actual hours

112 112 Hours or more

0-112

F1G. [CYNAMF CYNAML]: [CYAQRTH], [CYFUHU], Age [AGEIWDATE] [(Respondent)]

(In a typical week, how many hours [do you / does [he / she]] spend)

Doing leisure activities for enjoyment, for example, watching TV, doing physical activities that [you enjoy/ [he / she] enjoys], going online, or spending time with friends?

- IF R report hours other than weekly, PROBE: About how many hours per week would you say that is?
- IF R reports a range, PROBE: Within that range, what is your best estimate?
- ROUND DOWN for fractions less than ½ (0.5)
- ROUND UP for fractions ½ (0.5) or more

0 None

1-111 Actual hours

112 112 Hours or more

0-112

F1H. [CYNAMF CYNAML]: [CYAQRTH], [CYFUHU], Age [AGEIWDATE] [(Respondent)]

Now think about all the activities [you do / [he / she] does] in a typical week [*CURRENTLY WORKING*: outside of work, that is, when [you are / [he / she] is] not working].

[*CURRENTLY WORKING*: Outside of work, how / *ALL OTHERS*: How] often [do you / does [he / she]] interact with other people, including on the phone, in person, and online? Would you say never, rarely, sometimes, often, or almost always?

Never Rarely Sometimes Often Almost Always or Always

F1I. [CYNAMF CYNAML]: [CYAQRTH], [CYFUHU], Age [AGEIWDATE] [(Respondent)]

[*CURRENTLY WORKING*: Outside of work, how / *ALL OTHERS*: How] often [do you / does [he / she]] perform physically demanding activities, for example, those that require strength or physical effort for long periods of time? Would you say never, rarely, sometimes, often, or almost always?

Never Rarely Sometimes Often Almost Always or Always

F1J. [CYNAMF CYNAML]: [CYAQRTH], [CYFUHU], Age [AGEIWDATE] [(Respondent)]

[*CURRENTLY WORKING*: Outside of work, how / *ALL OTHERS*: How] often [do you / does [he / she]] perform mentally demanding activities, for example, analyzing information, learning new material, or solving complex problems? (Would you say never, rarely, sometimes, often, or almost always?)

Never Rarely Sometimes Often Almost Always or Always

F1K. [CYNAMF CYNAML]: [CYAQRTH], [CYFUHU], Age [AGEIWDATE] [(Respondent)]

[*CURRENTLY WORKING*: Outside of work, how / *ALL OTHERS*: How] often [do you / does [he / she]] feel rushed or pressed for time? (Would you say never, rarely, sometimes, often, or almost always?)

Never Rarely Sometimes Often Almost Always or Always

F1K END Rule: Whether Spouse/Partner in FU

| | | |
|---|--|-------------------|
| Spouse/Partner (CYAQRTH=201-222, CYFUHU=FU, FUMI) | → Repeat F1A-F1K; Then GO TO F4CKPT | No Spouse/Partner |
| | | ↓ |

END F1A_F1K

F4CKPT. CAI Checkpoint: Number of Current FU Members

| | | |
|--|---------------|----------------|
| 1. 2+ FU Members (COVERSCREEN.COUNT.FUCOUNT>1) | 5. All Others | → GO TO F7CKPT |
| | | ↓ |

F5. How many days a week does the family sit down and eat the main meal of the day together?

| |
|-------|
| 0 – 7 |
|-------|

F7CKPT. CAI Checkpoint: Whether Children Age 5-18 in FU in PYEAR

| | | |
|---|---------------|----------------|
| 1. Child Age 5-18 (FUP1YEAR.AGEIWDATE=5-18) | 5. All Others | → GO TO F6CKPT |
| | | ↓ |

F6AB. And during [PYEAR], did [1 CHILD IN FU PYEAR: [CYNAMF CYNAML] / ALL OTHERS: any child in your family between 5 and 18 years old] receive free or reduced-cost breakfasts or lunches at school? If "Yes": Was that breakfast, lunch, or both?

| | | | |
|------------------------|--------------------|--------------|----------------|
| 1. Yes, breakfast only | 2. Yes, lunch only | 3. Yes, both | 5. No, neither |
|------------------------|--------------------|--------------|----------------|

F6CKPT. CAI Checkpoint: Whether Children Age 15 or Younger in FU in PYEAR

| | | |
|--|---------------|------------------|
| 1. Child Age <16 (FUP1YEAR.AGEIWDATE<16) | 5. All Others | → GO TO F7B2CHPT |
| | | ↓ |

F7. How much did you [and your family living there] pay for child care in [PYEAR]?

- ENTER amount here, then SELECT unit of time on next screen (Week, Two weeks, Month, Year)

| | | | | |
|------|-------------|----------------|-------|--------------|
| \$ 0 | → GO TO F7A | \$ 1 – 999,997 | DK/RF | → GO TO F7MO |
|------|-------------|----------------|-------|--------------|

↓

F7PER. The amount entered is: [F6D] per ____

- SELECT the unit of time below

| | | | |
|---------|--------------|----------|---------|
| 3. Week | 4. Two weeks | 5. Month | 6. Year |
|---------|--------------|----------|---------|

| |
|---|
| 7. Other-specify (F7PERSPEC. Specify. (String 100)) |
|---|

F7MO. For which months in [PYEAR] was that?

- ENTER all that apply
- PROBE: Any others?

| | | | | | | |
|------------|-------------|--------------|-------------|--------------|--------------|---------|
| 1. January | 2. February | 3. March | 4. April | 5. May | 6. June | |
| 7. July | 8. August | 9. September | 10. October | 11. November | 12. December | 13. All |

F7A. Was any child enrolled in a day care center or family day care home in [PYEAR]?

1. Yes 5. No → GO TO F7B2CHPT



F7B. Were meals or snacks provided in any of these day care arrangements (attended last year)?

1. Yes 5. No → GO TO F7B2CHPT



F7B1. Did that day care center or family day care home participate in any government-sponsored food program, such as the Child and Adult Care Food Program?

1. Yes 5. No

F7B2CHPT. CAI CHECKPOINT: Whether Female Age 16-46 or Children Age 5 or Younger in FU in PYEAR

1. Female Age 16-46 Or Child Age<6 (FUP1YEAR.AGEIWDATE=16-46) (FUP1YEAR.AGEIWDATE<6) 5. All Others



GO TO F7CCKPT

F7B2. And during [PYEAR], did anyone in your family get food through the WIC program?

1. Yes 5. No

F7CCKPT. CAI Checkpoint: Whether FU Member Age 61 or Older in FU in PYEAR

1. FU Member Age>60 (FUP1YEAR.AGEIWDATE>60) 5. All Others → GO TO F8



F7C. During [PYEAR], did you [or anyone in your family] receive free or reduced-cost meals for the elderly?

1. Yes 5. No

F8. Did you [or anyone else in your family] receive food stamp benefits, that is, either food stamps or a food stamp benefit card, at any time in [P2YEAR], two years ago?

- **If needed:** Food stamp benefits are issued by SNAP, the federal Supplemental Nutrition Assistance Program, also called Food Stamp Program.

1. Yes 5. No

F11. Did you [or anyone else in your family] receive food stamp benefits, (that is, either food stamps or a food stamp benefit card,) at any time last year, in [PYEAR]?

- **If needed:** Food stamp benefits are issued by SNAP, the federal Supplemental Nutrition Assistance Program, also called Food Stamp Program.

1. Yes 5. No → GO TO F14



F12. How much did you receive (in food stamp benefits) in [PYEAR]?

- **If needed:** Food stamp benefits are issued by SNAP, the federal Supplemental Nutrition Assistance Program, also called Food Stamp Program.
- **ENTER amount here, then SELECT unit of time on next screen (Week, Two weeks, Month, Year)**

\$ 1 – 999,997 DK/RF → GO TO F13



F12PER. The amount entered is: [F12] per ____

- SELECT the unit of time below

| | | | |
|--|--------------|----------|---------|
| 3. Week | 4. Two weeks | 5. Month | 6. Year |
| 7. Other-specify (F12PERSPEC. Specify. (String 100)) | | | |

F13. During which months was that?

- ENTER all that apply
- PROBE: Any others?

| | | | | | | |
|------------|-------------|--------------|-------------|--------------|--------------|---------|
| 1. January | 2. February | 3. March | 4. April | 5. May | 6. June | |
| 7. July | 8. August | 9. September | 10. October | 11. November | 12. December | 13. All |

F14. Did you [or anyone else now living in your family] use food stamp benefits last month?

- If needed: Food stamp benefits are issued by SNAP, the federal Supplemental Nutrition Assistance Program, also called Food Stamp Program.

| | | |
|--------|-------|----------------|
| 1. Yes | 5. No | → GO TO F18F22 |
|--------|-------|----------------|



F15. How many members of your family were covered (by food stamp benefits)?

- If needed: Food stamp benefits are issued by SNAP, the federal Supplemental Nutrition Assistance Program, also called Food Stamp Program.
- ENTER [7] for seven or more family members

| |
|-------|
| 1 - 7 |
|-------|

F16. How much did you receive (in food stamp benefits) last month?

- If needed: Food stamp benefits are issued by SNAP, the federal Supplemental Nutrition Assistance Program, also called Food Stamp Program.

| |
|----------------|
| \$ 1 - 999,997 |
|----------------|

F17. In addition to what you buy with food stamp benefits, do you [or anyone else in your family] spend any money on food that you use at home?

- If needed: Food stamp benefits are issued by SNAP, the federal Supplemental Nutrition Assistance Program, also called Food Stamp Program.

| | | |
|--------|-------|----------------|
| 1. Yes | 5. No | → GO TO F19F23 |
|--------|-------|----------------|



F18F22. [F14=YES: How much do you spend on that food in an average week? / F14<>YES: How much do you [and everyone else in your family] spend on food that you use at home in an average week?

- [HU/CS IN FU: IF R lives with non-FU members, PROBE: Is that only your (FU's) share of the food?]
- ENTER amount here, then SELECT unit of time on next screen (Week, Two weeks, Month, Year)

| | | | | |
|--------------------------|----------------|---------------------|-------|----------------|
| [F17 NOT ASKED: \$ 0.00] | → GO TO F19F23 | \$ 1.00 - 99,997.99 | DK/RF | → GO TO F19F23 |
|--------------------------|----------------|---------------------|-------|----------------|



F18F22PER. The amount entered is: [F18F22] per ____

- SELECT the unit of time below

| | | | |
|---|--------------|----------|---------|
| 3. Week | 4. Two weeks | 5. Month | 6. Year |
| 7. Other-specify (F18F22PERSPEC. Specify. (String 100)) | | | |

F19F23. Do you have any food delivered to the door which isn't included in that?

1. Yes 5. No → GO TO F21F25



F20F24. How much do you spend on that food?

- [HU/CS IN FU: IF R lives with non-FU members, PROBE: Is that only your (FU's) share of the food?]
- ENTER amount here, then SELECT unit of time on next screen (Week, Two weeks, Month, Year)

\$ 1.00 – 99,997.99 DK/RF → GO TO F21F25



F20F24PER. The amount entered is: [F20F24] per ____

- SELECT the unit of time below

3. Week 4. Two weeks 5. Month 6. Year

7. Other-specify (F20F24PERSPEC. Specify. (String 100))

F21F25. About how much do you [and everyone else in your family] spend eating out?

- [HU/CS IN FU: IF R lives with non-FU members, PROBE: Is that only your (FU's) share of the food?]
- ENTER amount here, then SELECT unit of time on next screen (Week, Two weeks, Month, Year)

\$ 0.00 → GO TO FOOD1 \$ 1.00 – 99,997.99 DK/RF → GO TO FOOD1



F21F25PER. The amount entered is: [F21F25] per ____

- SELECT the unit of time below

3. Week 4. Two weeks 5. Month 6. Year

7. Other-specify (F21F25PERSPEC. Specify. (String 100))

FOOD1CKPT. CAI Checkpoint: Respondent

1. R=Proxy (RESPONDENT=7) → GO TO F47 2. R=Head, Spouse/Partner, OFUM (RESPONDENT=1-4)



SECTION_F.FOOD

Adult Stage 1

FOOD1. Now I'm going to read you several statements that people have made about their food situation. For these statements, please tell me whether the statement was often true, sometimes true, or never true for [you / your household] in the last 12 months - that is, since last [CURRMONTH].

The first statement is "[SINGLE HEAD: I / SP IN FU: We] worried whether [SINGLE HEAD: my / SP IN FU: our] food would run out before [SINGLE HEAD: I / SP IN FU: we] got money to buy more."

Was that often true, sometimes true, or never true for [SINGLE HEAD: you / SP IN FU: your household] in the last 12 months?

1. Often true 2. Sometimes true 3. Never true

FOOD2. "The food that [I / we] bought just didn't last, and [I / we] didn't have money to get more."
(Was that often, sometimes, or never true for [you / your household] in the last 12 months?)

1. Often true 2. Sometimes true 3. Never true

FOOD3. "[I / We] couldn't afford to eat balanced meals."
(Was that often, sometimes, or never true for [you / your household] in the last 12 months?)

1. Often true 2. Sometimes true 3. Never true

Adult Stage 2

FOOD4 Rule: Whether Any Food1-Food3 Endorsed As Often/Sometimes

| |
|---|
| <input type="checkbox"/> One or More FOOD1-FOOD3 = Often/Sometimes <input type="checkbox"/> All Others → GO TO FOOD11CKPT |
| ↓ |

FOOD4. In the last 12 months, since last [CURRMONTH], did [you / you or other adults in your household] ever cut the size of your meals or skip meals because there wasn't enough money for food?

1. Yes 5. No → GO TO FOOD6

↓

FOOD5. How often did this happen - almost every month, some months but not every month, or in only 1 or 2 months?

1. Almost every month 2. Some months but not every month 3. Only 1 or 2 months

FOOD6. In the last 12 months, (since last [CURRMONTH]), did you ever eat less than you felt you should because there wasn't enough money for food?

1. Yes 5. No

FOOD7. In the last 12 months, (since last [CURRMONTH]), were you ever hungry but didn't eat because there wasn't enough money for food?

1. Yes 5. No

FOOD8. In the last 12 months, did you lose weight because there wasn't enough money for food?

1. Yes 5. No

Adult Stage 3

FOOD9 Rule: Whether Any Food6-Food8 Endorsed

| |
|---|
| <input type="checkbox"/> One or More FOOD6-FOOD8 = Yes <input type="checkbox"/> All Others → GO TO FOOD11CKPT |
| ↓ |

FOOD9. In the last 12 months, (since last [CURRMONTH]), did [you / you or other adults in your household] ever not eat for a whole day because there wasn't enough money for food?

1. Yes 5. No → GO TO FOOD11CKPT

↓

FOOD10. How often did this happen - almost every month, some months but not every month, or in only 1 or 2 months?

1. Almost every month 2. Some months but not every month 3. Only 1 or 2 months

Child Stage 1

FOOD11CKPT. CAI Checkpoint: Whether Children Age 1-17 in FU

| | |
|--|--|
| <input type="checkbox"/> 1. One or More Children in FU (CYAQRTH<>101-222,881-882,901-922; CYFUHU=FU, FUMI; AGEIWDAT<18) | <input type="checkbox"/> 5. All Others → GO TO F47 |
| ↓ | |

FOOD11. Now I'm going to read you several statements that people have made about the food situation of their children. For these statements, please tell me whether the statement was often true, sometimes true, or never true in the last 12 months for your [child / children living in the household who are under 18 years old].

"[I / We] relied on only a few kinds of low-cost food to feed [my / our] [*1 CHILD: child / >1 CHILD: children*] because [I was / we were] running out of money to buy food."

Was that often, sometimes, or never true for [you / your household] in the last 12 months, (since last [CURRMONTH])?

1. Often true 2. Sometimes true 3. Never true

FOOD12. "[I / We] couldn't feed [my / our] [child / children] a balanced meal, because [I / we] couldn't afford that." (Was that often, sometimes, or never true for [you / your household] in the last 12 months, (since last [CURRMONTH]))?

1. Often true 2. Sometimes true 3. Never true

FOOD13. "[My / Our] [child was / children were] not eating enough because [I / we] just couldn't afford enough food." (Was that often, sometimes, or never true for [you / your household] in the last 12 months, (since last [CURRMONTH]))?

1. Often true 2. Sometimes true 3. Never true

Child Stage 2

FOOD14 Rule: Whether Any Food11-Food13 Endorsed As Often/Sometimes

| | | |
|--|-------------------------------------|-------------|
| <input type="checkbox"/> One or More FOOD11-FOOD13 = Often/Sometimes | <input type="checkbox"/> All Others | → GO TO F47 |
| ↓ | | |

FOOD14. In the last 12 months, since [CURRMONTH] of last year, did you ever cut the size of [your child's / any of the children's] meals because there wasn't enough money for food?

1. Yes 5. No

FOOD15. In the last 12 months, (since last [CURRMONTH]), did [your child / any of the children] ever skip meals because there wasn't enough money for food?

1. Yes 5. No → GO TO FOOD17

↓

FOOD16. How often did this happen?

(Would you say almost every month, some months but not every month, or in only 1 or 2 months?)

1. Almost every month 2. Some months but not every month 3. Only 1 or 2 months

FOOD17. In the last 12 months, (since last [CURRMONTH]), [was your child / were the children] ever hungry but you just couldn't afford more food?

1. Yes 5. No

FOOD18. In the last 12 months, (since last [CURRMONTH]), did [your child / the children] ever not eat for a whole day because there wasn't enough money for food?

1. Yes 5. No

END FOOD

F47. These next questions are about personal vehicles and transportation. Do you [or anyone else in your family living there] own or lease a car or other vehicle for personal use?

- DO NOT include motorcycles or vehicles used exclusively by institutionals, HU or HUCS people

1. Yes 5. No → GO TO F81A



F48. Altogether, how many vehicles do you [or anyone else in your family living there] own or lease (for your personal use)?

- DO NOT include motorcycles or vehicles used exclusively by institutionals, HU or HUCS people

1 – 10 DK RF → GO TO F81A



SECTION F.F49SERIES.F49[1-3] [1-3]=Which vehicle

F49A. [VEHICLE 1: I would like to ask a few questions about [F48=1: that vehicle / F48>1: those vehicles, starting with the newest]. / ALL OTHERS: For the next vehicle:]

What is the year?

1901 – [C2YEAR]

F49B. What is the make and model of the vehicle?

- PROBE if multiple models are listed with the same name
- PROBE for hybrid or non-hybrid as needed. If R doesn't know, SELECT the non-hybrid model

MAKE & MODEL DK/RF → GO TO F49BCKPT



F49B1. Hybrid Indicator from Car Database (0, 1)

F49C. 8-Digit Vehicle Model ID from Car Database

F49BCKPT. CAI Checkpoint: Whether Vehicle is Hybrid; Whether Vehicle Older Than 1999

| | | |
|---------------------|--------------------------------|---------------------------------|
| 1. Hybrid (F49B1=1) | 2. Older Than 1999 (F49A<1999) | 5. All Others (incl F49A=DK/RF) |
| GO TO F53 RULE | | ↓ |

F49B2. [F49A F49B]

Is this vehicle a hybrid, plug-in hybrid, electric-only, or alternative fuel use vehicle, or none of the above?

- If R says Yes, PROBE: Is it a hybrid, plug-in hybrid, electric, or alternative fuel?

EV: Electric vehicle

BEV: Battery electric vehicle

CNG: Compressed natural gas

LPG: Liquefied petroleum gas

1. Yes, hybrid 2. Yes, plug-in hybrid 3. Yes, electric vehicle or battery electric vehicle (EV, BEV)

4. Yes, alternative fuel vehicle (CNG, LPG) 5. No; None of the above

7. Other-specify (F49B2SPEC. Please specify. (String 100))

F53 Rule: Whether More Vehicles at F48

| | | |
|---------------|---|------------------|
| More Vehicles | → Repeat F49A-F49B2; Max=3; Then GO TO F53 | No More Vehicles |
| | | ↓ |

END F49

SECTION_F.VEHICLE[1-3] [1-3]=Which vehicle

F53. [YEAR MAKE-MODEL]

(And) for your [F49B=DK/RF: [first / second / third] vehicle / ALL OTHERS: [F49B]], did you buy it, lease it, receive it as a gift, or what?

1. Bought 2. Leased 3. Received as a gift

7. Other-specify (F53SPEC. Specify. (String 100)) DK/RF → GO TO F75 RULE



F55. [YEAR MAKE-MODEL]

In what year did you [F53=BOUGHT: buy / F53=LEASED: lease / F53=GIFT: receive / F53=OTHER: acquire] it?

1901 – [CYEAR]

F57. [YEAR MAKE-MODEL]

Not counting routine use to get to and from work, is this vehicle also used for business purposes?

1. Yes 5. No → GO TO F60 RULE



F58. [YEAR MAKE-MODEL]

Is it used primarily for business purposes?

- DEFINITION: more than half of the miles driven per year are for business

1. Yes 5. No

F60 Rule: Whether This Vehicle Bought or Leased in P2YEAR-CYEAR

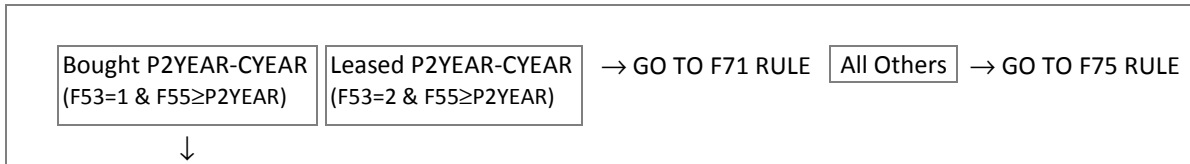

F61. [YEAR MAKE-MODEL]

What was the total price of the [F49B=DK/RF: [first / second / third] vehicle / ALL OTHERS: [F49B]]?

\$ 1 – 999,997

F64. [YEAR MAKE-MODEL]

How much did you pay down in cash?

- IF necessary: Over and above the value of your trade-in or sale.

\$ 0 – 999,997

F65. [YEAR MAKE-MODEL]

Did you borrow or finance part of the total price?

1. Yes 5. No → GO TO F75 RULE



F66. [YEAR MAKE-MODEL]

How much did you borrow, not including financing charges?

\$ 1 – 999,997

F67. [YEAR MAKE-MODEL]

How much are your current payments and how often are they made?

- ENTER [0] if paid off
- ENTER amount here, then SELECT unit of time on next screen (Month, Year)

→ GO TO F75 RULE → GO TO F75 RULE



F67PER. The amount entered is: [F67] per ____

- SELECT the unit of time below

F69. [YEAR MAKE-MODEL]

How many payments did you agree to make altogether?

[Monthly payments conversions](#)

3 years = 36 6 years = 72

4 years = 48 7 years = 84

5 years = 60

F70. [YEAR MAKE-MODEL]

How many payments have you made?

[Monthly payments conversions](#)

3 years = 36 6 years = 72

4 years = 48 7 years = 84

5 years = 60

F71 Rule: Whether This Vehicle Leased in P2YEAR-CYEAR

→ GO TO F75 RULE



F71. [YEAR MAKE-MODEL]

(And for your [F49B=DK/RF: [first / second / third] vehicle / ALL OTHERS: [F49B]],) how much was your initial outlay for that lease - including your down payment and any fees?

F72. [YEAR MAKE-MODEL]

How much are your payments and how often are they made?

- ENTER amount here, then SELECT unit of time on next screen (Month, Year)

→ GO TO F75 RULE



F72PER. The amount entered is: [F72] per ____

- SELECT the unit of time below

F73. [YEAR MAKE-MODEL]

How many payments did you agree to make altogether?

[Monthly payments conversions](#)

3 years = 36 6 years = 72

4 years = 48 7 years = 84

5 years = 60

F74. [YEAR MAKE-MODEL]

How many payments have you made?

[Monthly payments conversions](#)

3 years = 36 6 years = 72

4 years = 48 7 years = 84

5 years = 60

F75 Rule: Whether More Vehicles at F48

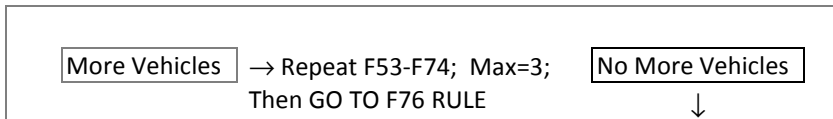

END VEHICLE

F76 Rule: Whether FU Has a Vehicle

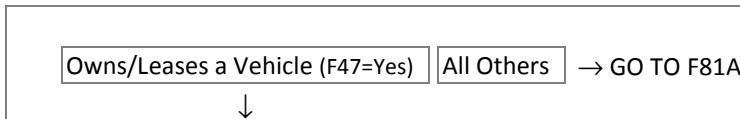

F77. [ALL VEHICLES: YEAR MAKE-MODEL]

How much do you [and your family living there] pay for car insurance [*F48=2+, DK: for all of your vehicles*]?

- **IF necessary:** Please give me your best estimate.
- **ENTER amount here, then SELECT unit of time on next screen (Every 6 months, Month, Year)**

→ GO TO F80D → GO TO F80D

↓

F77PER. The amount entered is: [F77] per ____

- **SELECT the unit of time below**

F80D. How much did you [and your family living there] pay for car repairs and maintenance in the last 12 months?

- **If needed:** We're talking about the last 12 months
- **ENTER to the nearest dollar.**
- **If None, ENTER [0]**

F78 Rule: Whether Any Vehicle Bought or Leased Before P2YEAR

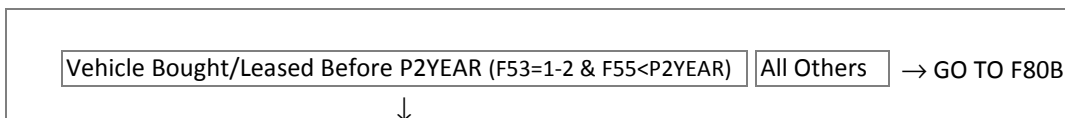

F79. [Vehicles Bought/Leased < [P2YEAR]: YEAR MAKE-MODEL]

[ANY VEHICLE BOUGHT/LEASED [P2YEAR] OR LATER: Other than the car payments you already told me about, how / ALL OTHERS: How] much did you [and your family living there] pay in car payments in [LAST MONTH]?

- If needed: We're talking about last month ([LAST MONTH])
- INCLUDE vehicle purchase and lease payments not already covered

\$ 0 – 999,997

F80B. Altogether for the month of [LAST MONTH], how much did you [and your family living there] pay for each of these transportation related expenses. Do not include costs associated with trips and vacations, which we will ask about later.

Gasoline?

- If needed: We're talking about last month ([LAST MONTH])
- ENTER to the nearest dollar.
- If None, ENTER [0]

\$ 0 – 99,997

F80C. (Altogether for the month of [LAST MONTH], how much did you [and your family living there] pay for each of these transportation related expenses. Do not include costs associated with trips and vacations, which we will ask about later.)

Parking and car pool?

- If needed: We're talking about last month ([LAST MONTH])
- ENTER to the nearest dollar.
- If None, ENTER [0]

\$ 0 – 99,997

F81A. [F47=YES: (Altogether for the month of [LAST MONTH], how much did you [and your family living there] pay for each of these transportation related expenses. (Do not include costs associated with trips and vacations, which we will ask about later.) / F47<>YES: Altogether for the month of [LAST MONTH], how much did you [you and your family living there] pay for each of these transportation related expenses. Do not include costs associated with trips and vacations, which we will ask about later.)

Bus fares and train fares?

- If needed: We're talking about last month ([LAST MONTH])
- ENTER to the nearest dollar.
- If None, ENTER [0]

\$ 0 – 99,997

F81B. (Altogether for the month of [LAST MONTH], how much did you [and your family living there] pay for each of these transportation related expenses. Do not include costs associated with trips and vacations, which we will ask about later.)

Taxicabs?

- Includes Uber, Lyft
- If needed: We're talking about last month ([LAST MONTH])
- ENTER to the nearest dollar.
- If None, ENTER [0]

\$ 0 – 99,997

F81C. (Altogether for the month of [LAST MONTH], how much did you [and your family living there] pay for each of these transportation related expenses. Do not include costs associated with trips and vacations, which we will ask about later.)

Other transportation costs?

- If needed: We're talking about last month ([LAST MONTH])
- ENTER to the nearest dollar.
- If None, ENTER [0]

→ GO TO F82



F81CSPEC. What were those other costs?

F82. In [PYEAR], did you [and your family living there] have any school-related expenses such as:

Tuition or tutoring (not including any amounts already mentioned for day care or nursery school);

Room and board for a family member who is away at school;

Purchase or rental of books, supplies, uniforms, or equipment including computers and software?

→ GO TO F86A



F83. How much in total were these expenses?

F84. In [PYEAR], were there any other school-related expenses not already covered in the previous question?

→ GO TO F86A



F85. What other types of school-related expenses did you have?

F86. Altogether, how much were these other expenses?

F86A. [*F82=YES OR F84=YES*: Not including any amounts already reported, how / *ALL OTHERS*: How] much did you [and your family living there] spend altogether in [PYEAR] on computers, laptops, tablets, cell phones, game players, and software for these devices?

→ GO TO F87



F86A1. Would it amount to \$600 or more?

→ GO TO F87



F86A3. (Would it amount to)
\$900 or more?



F86A2. (Would it amount to)
\$400 or more?

F87. Next, let me ask you about some other household expenses. Please indicate to the best of your ability, the amount spent on each of these items altogether during [PYEAR].

How much did you [and your family living there] spend altogether in [PYEAR] on home repairs and maintenance, including materials plus any costs for hiring a professional?

- ENTER amount here, then SELECT unit of time on next screen (Month, Year)

| | | |
|---|----------------|--|
| \$ 0 → GO TO F88 | \$ 1 – 999,997 | DK/RF |
| ↓ | | ↓ |
| <p>F87PER. The amount entered is: [F87] per __</p> <ul style="list-style-type: none"> • SELECT the unit of time below <p>5. Month 6. Year</p> <p>7. Other-specify (F87PERSPEC. Please specify. (String 100))</p> | | <p>F87A. Would it amount to \$400 or more?</p> <p>1. Yes 5. No DK/RF → GO TO F88</p> <p style="text-align: center;">↓ ↓</p> <p>F87B. \$1000 or more? F87C. \$100 or more?</p> <p>1. Yes 5. No 1. Yes 5. No</p> |

F88. (How much did you [and your family living there] spend altogether in [PYEAR]...)

On household furnishings and equipment, including household textiles, furniture, floor coverings, major appliances, small appliances and miscellaneous housewares?

- ENTER amount here, then SELECT unit of time on next screen (Month, Year)

| | | |
|---|----------------|--|
| \$ 0 → GO TO F89 | \$ 1 – 999,997 | DK/RF |
| ↓ | | ↓ |
| <p>F88PER. The amount entered is: [F88] per __</p> <ul style="list-style-type: none"> • SELECT the unit of time below <p>5. Month 6. Year</p> <p>7. Other-specify (F88PERSPEC. Please specify. (String 100))</p> | | <p>F88A. Would it amount to \$500 or more?</p> <p>1. Yes 5. No DK/RF → GO TO F89</p> <p style="text-align: center;">↓ ↓</p> <p>F88B. \$1500 or more? F88C. \$100 or more?</p> <p>1. Yes 5. No 1. Yes 5. No</p> |

F89. (How much did you [and your family living there] spend altogether in [PYEAR]...)

On clothing and apparel, including footwear, outerwear, and products such as watches or jewelry?

- ENTER amount here, then SELECT unit of time on next screen (Month, Year)

| | | |
|---|----------------|--|
| \$ 0 → GO TO F90 | \$ 1 – 999,997 | DK/RF |
| ↓ | | ↓ |
| <p>F89PER. The amount entered is: [F89] per __</p> <ul style="list-style-type: none"> • SELECT the unit of time below <p>5. Month 6. Year</p> <p>7. Other-specify (F89PERSPEC. Please specify. (String 100))</p> | | <p>F89A. Would it amount to \$700 or more?</p> <p>1. Yes 5. No DK/RF → GO TO F90</p> <p style="text-align: center;">↓ ↓</p> <p>F89B. \$1500 or more? F89C. \$200 or more?</p> <p>1. Yes 5. No 1. Yes 5. No</p> |

F90. (How much did you [and your family living there] spend altogether in [PYEAR]...)

On trips and vacations, including transportation, accommodations, and recreational expenses on trips?

- ENTER amount here, then SELECT unit of time on next screen (Month, Year)

| | | |
|--|--|-------|
| \$ 0 → GO TO F91 | \$ 1 – 999,997 | DK/RF |
| ↓ | | |
| <p>F90PER. The amount entered is: [F90] per __</p> <ul style="list-style-type: none"> • SELECT the unit of time below <div style="border: 1px solid black; padding: 2px; display: inline-block; margin-bottom: 5px;">5. Month</div> <div style="border: 1px solid black; padding: 2px; display: inline-block; margin-left: 10px; margin-bottom: 5px;">6. Year</div> <div style="border: 1px solid black; padding: 2px; display: inline-block; margin-top: 5px;">7. Other-specify (F90PERSPEC. Please specify. (String 100))</div> | <p>F90A. Would it amount to \$500 or more?</p> <div style="display: flex; justify-content: space-between; align-items: center;"> <div style="border: 1px solid black; padding: 2px 10px;">1. Yes</div> <div style="border: 1px solid black; padding: 2px 10px;">5. No</div> <div style="border: 1px solid black; padding: 2px 10px;">DK/RF → GO TO F91</div> </div> <p style="text-align: center;">↓</p> <div style="display: flex; justify-content: space-around;"> <div style="text-align: center;"> <p>F90B. \$1500 or more?</p> <div style="display: flex; justify-content: center; gap: 10px;"> <div style="border: 1px solid black; padding: 2px 10px;">1. Yes</div> <div style="border: 1px solid black; padding: 2px 10px;">5. No</div> </div> </div> <div style="text-align: center;"> <p>F90C. \$200 or more?</p> <div style="display: flex; justify-content: center; gap: 10px;"> <div style="border: 1px solid black; padding: 2px 10px;">1. Yes</div> <div style="border: 1px solid black; padding: 2px 10px;">5. No</div> </div> </div> </div> | |

F91. (How much did you [and your family living there] spend altogether in [PYEAR]...)

On recreation and entertainment, including tickets to movies, sporting events, and performing arts and hobbies including exercise, bicycles, trailers, camping, photography, and reading materials? [F90<>0: Do not include costs associated with the trips and vacations you mentioned previously.]

- ENTER amount here, then SELECT unit of time on next screen (Month, Year)

| | | |
|--|--|-------|
| \$ 0 → GO TO SECTION G | \$ 1 – 999,997 | DK/RF |
| ↓ | | |
| <p>F91PER. The amount entered is: [F91] per __</p> <ul style="list-style-type: none"> • SELECT the unit of time below <div style="border: 1px solid black; padding: 2px; display: inline-block; margin-bottom: 5px;">5. Month</div> <div style="border: 1px solid black; padding: 2px; display: inline-block; margin-left: 10px; margin-bottom: 5px;">6. Year</div> <div style="border: 1px solid black; padding: 2px; display: inline-block; margin-top: 5px;">7. Other-specify (F91PERSPEC. Please specify. (String 100))</div> | <p>F91A. Would it amount to \$500 or more?</p> <div style="display: flex; justify-content: space-between; align-items: center;"> <div style="border: 1px solid black; padding: 2px 10px;">1. Yes</div> <div style="border: 1px solid black; padding: 2px 10px;">5. No</div> <div style="border: 1px solid black; padding: 2px 10px;">DK/RF → GO TO SECTION G</div> </div> <p style="text-align: center;">↓</p> <div style="display: flex; justify-content: space-around;"> <div style="text-align: center;"> <p>F91B. \$1500 or more?</p> <div style="display: flex; justify-content: center; gap: 10px;"> <div style="border: 1px solid black; padding: 2px 10px;">1. Yes</div> <div style="border: 1px solid black; padding: 2px 10px;">5. No</div> </div> </div> <div style="text-align: center;"> <p>F91C. \$200 or more?</p> <div style="display: flex; justify-content: center; gap: 10px;"> <div style="border: 1px solid black; padding: 2px 10px;">1. Yes</div> <div style="border: 1px solid black; padding: 2px 10px;">5. No</div> </div> </div> </div> | |

END SECTION_F

Section G: Income; OFUM Education

[TOC](#)

SECTION_G

G1. We try to understand how people are getting along financially, so now I have some questions about earnings and income.

[ENTER \[1\] to continue](#)

G1A. CAI Checkpoint: Whether Head or Spouse/Partner is a Farmer or Rancher on Current Main Job

| | | |
|---|--|--------------------------------------|
| Farmer/Rancher (JOBTYPE=CMJ & BC28=Yes) | <input type="text" value="5. All Others"/> | → GO TO G5 |
| <input type="text" value="1. Head Only"/> | <input type="text" value="2. SP Only"/> | <input type="text" value="3. Both"/> |
| ↓ | | |

G2. What were [R=HEAD: [your / your (and [SP]'s) / R=SP [your / your (and [HEAD]'s) / R=OFUM, Proxy: [HEAD / SP]'s / [HEAD]'s and [SP]'s] total receipts from farming in [PYEAR], including soil bank payments and commodity credit loans?

G3. What were [[your / your (and [SP]'s) / [your / your (and [HEAD]'s) / [HEAD / SP]'s / [HEAD]'s and [SP]'s] total operating expenses, not counting living expenses?

G4CKPT. CAI Checkpoint: Whether G2 or G3 is Non-Response

| | | |
|--|--|--|
| <input type="text" value="1. G2=DK, RF or G3=DK, RF"/> | <input type="text" value="5. All Others"/> | → Assign G4=G2 minus G3; Then GO TO G5 |
| ↓ | | |

G4. (And) what was the net income from farming?

- [Receipts](#): [Don't Know / Refused / \$[G2]]
- [Expenses](#): [Don't Know / Refused / \$[G3]]

G5. Did [you / [HEAD]] [or anyone else in the family there] own a business at any time in [PYEAR] or have a financial interest in any business enterprise?

→ GO TO G12

↓

G6. How many businesses or financial interests did you have in [PYEAR]?

→ GO TO G7A → GO TO G12

↓

SECTION_G.G7_G11[1-5] [1-5]=Which business

G7. [LOOP 1: I'll be asking this next series of questions about each business separately. We can begin with whichever business you choose. / ALL OTHERS: And now some questions about the next business.]

- [ENTER \[1\] to continue](#)

G7A. Business #[1-5]

What kind of business was that?

String 500

G7B. Business #[1-5]

What was the name of (the/that) business?

- **IF necessary:** This information will help us to process employment information you gave us. The name itself will never be released as part of data from the study.
- **IWER: IF no employer name is given by R, ask for job title or anything that can help identify the job.**

String 25

G8. Business #[1-5]: [G7B]

Who in the family owned that business?

- **ENTER all that apply**
- **PROBE:** Any others?

1 – 24. [CYNAMF CYNAML], [CYAQRTH], [CYFUHU]

AQSN list of FU Members w/CYFUHU = FU, FUMI≤PYEAR, MO≥PYEAR, DECD≥PYEAR, MILIT, EDUC, HLTH, OTHR)

97. Owner not on family list (G8SPEC. Who was that? (String 100))

SECTION_G.G7_G11[1-5].G9_G10[1-2] [1-5]=Which business; [1]=Current Head, [2]=Current Spouse/Partner
G9AQSN. AQSN of Current Head (Spouse/Partner)

G9A. Business #[1-5]: [G7B] - [CYNAMF CYNAML]: [CYAQRTH], [CYFUHU], Age [AGEIWDATE] [(Respondent)]

Did [you / [HEAD / SP]] put in any work time for this business in [PYEAR]?

- **PROBE if inconsistent with employment section**

1. Yes 5. No → GO TO G9BB RULE

↓

G9B. Business #[1-5]: [G7B] - [CYNAMF CYNAML]: [CYAQRTH], [CYFUHU], Age [AGEIWDATE]

[(Respondent)]

Did you tell me about this work earlier?

[READ employers if needed](#)

[\[List of PYEAR Employers from EHC\]](#)

1. Yes, these work hours were reported

→ GO TO G9 RULE

5. No, these work hours were not reported

↓

G9J1H. Business #[1-5]: [G7B] - [CYNAMF CYNAML]: [CYAQRTH], [CYFUHU], Age [AGEIWDATE]

[(Respondent)]

Then I would like to ask you some questions now about this business and [your / [HEAD / SP]'s] work in it.

- **ENTER [1] to continue**

1. Continue

G9J3H. Business #[1-5]: [G7B] - [CYNAMF CYNAML]: [CYAQRTH], [CYFUHU], Age [AGEIWDATE]

[(Respondent)]

What sort of work did [you / he / she] do?

- **DO NOT PROBE**

String 500

G9J3AH. Business #[1-5]: [G7B] - [CYNAMF CYNAML]: [CYAQRTH], [CYFUHU], Age [AGEIWDATE] [(Respondent)]

What was the official title of [your / [HEAD / SP]'s] job? (The title that the business used.)

- DO NOT PROBE

String 200

G9J4H. Business #[1-5]: [G7B] - [CYNAMF CYNAML]: [CYAQRTH], [CYFUHU], Age [AGEIWDATE] [(Respondent)]

And, how many weeks did [you / he / she] work at this business in [PYEAR]?

1 – 52

G9J5H. Business #[1-5]: [G7B] - [CYNAMF CYNAML]: [CYAQRTH], [CYFUHU], Age [AGEIWDATE] [(Respondent)]

On average, how many hours a week did [you / he / she] work at this business?

- ROUND DOWN for fractions less than $\frac{1}{2}$ (0.5)
- ROUND UP for fractions $\frac{1}{2}$ (0.5) or more

1 – 112

G9J6HMO. Business #[1-5]: [G7B] - [CYNAMF CYNAML]: [CYAQRTH], [CYFUHU], Age [AGEIWDATE] [(Respondent)]

In what month and year did [you / he / she] start working at this business?

- SELECT Month and [Enter] to go to next screen for year
- IF NECESSARY: What would be your best estimate?

| | | | | | |
|--------------|--------------|------------|--------------|-------------|----------|
| 1. January | 2. February | 3. March | 4. April | 5. May | |
| 6. June | 7. July | 8. August | 9. September | 10. October | |
| 11. November | 12. December | 21. Winter | 22. Spring | 23. Summer | 24. Fall |

G9J6HYR. Business #[1-5]: [G7B] - [CYNAMF CYNAML]: [CYAQRTH], [CYFUHU], Age [AGEIWDATE] [(Respondent)]

- The month entered is: [9J6HMO]

- ENTER the year below

1901- [PYEAR] Actual year

9997 Before [P2YEAR, DK exact year]

1901 -- [PYEAR] 9997. Before [P2YEAR] , DK Exact Year

G9J7H. Business #[1-5]: [G7B] - [CYNAMF CYNAML]: [CYAQRTH], [CYFUHU], Age [AGEIWDATE] [(Respondent)]

In which months during [PYEAR] [were you / was [he / she]] working at this business?

- ENTER all that apply
- PROBE: Any others?

| | | | | |
|--------------|--------------|-----------|--------------|-------------|
| 1. January | 2. February | 3. March | 4. April | 5. May |
| 6. June | 7. July | 8. August | 9. September | 10. October |
| 11. November | 12. December | 13. All | | |

G9J8H. Business #[1-5]: [G7B] - [CYNAMF CYNAML]: [CYAQRTH], [CYFUHU], Age [AGEIWDATE] [(Respondent)]

[Have you / Has [he / she]] stopped working at this business?

1. Yes 5. No → GO TO G9 RULE

↓

G9J9HMO. Business #[1-5]: [G7B] - [CYNAMF CYNAML]: [CYAQRTH], [CYFUHU], Age [AGEIWDAT] [(Respondent)]

In what month and year was that?

- SELECT Month and [Enter] to go to next screen for year
- IF NECESSARY: What would be your best estimate?

| | | | |
|--------------|-------------|--------------|--------------|
| 1. January | 2. February | 3. March | 4. April |
| 5. May | 6. June | 7. July | 8. August |
| 9. September | 10. October | 11. November | 12. December |
| 21. Winter | 22. Spring | 23. Summer | 24. Fall |

G9J9HYR. Business #[1-5]: [G7B] - [CYNAMF CYNAML]: [CYAQRTH], [CYFUHU], Age [AGEIWDAT] [(Respondent)]

The month entered is: [G9J9HMO]

- ENTER the year below
9996 [PYEAR] or [CYEAR] and DK which

| | | |
|---------|---------|--|
| [PYEAR] | [CYEAR] | 9996. [PYEAR] - [CYEAR], DK Which Year |
|---------|---------|--|

G9J10H. Business #[1-5]: [G7B] - [CYNAMF CYNAML]: [CYAQRTH], [CYFUHU], Age [AGEIWDAT] [(Respondent)]

What happened - did it go out of business, did [you / he / she] quit, or what?

| |
|------------|
| String 500 |
|------------|

G9 RULE: Whether Spouse/Partner in FU

| | | |
|---|---------------------------------------|-------------------|
| Spouse/Partner (CYAQRTH=201-222, CYFUHU=FU, FUMI) | → Repeat G9A-G9J10; Then GO TO G10 | No Spouse/Partner |
| | | ↓ |

END G9_G10

G10. Business #[1-5]: [G7B] - [CYNAMF CYNAML]: [CYAQRTH], [CYFUHU], Age [AGEIWDAT] [(Respondent)]
(Please remind me,) was it a corporation or an unincorporated business?

| | | | |
|----------------|-------------------|--|-------|
| 1. Corporation | 2. Unincorporated | 7. Other-specify (G10SPEC. Specify (String 100)) | DK/RF |
|----------------|-------------------|--|-------|

GO TO G11DCKPT



G11. Business #[1-5]: [G7B] - [CYNAMF CYNAML]: [CYAQRTH], [CYFUHU], Age [AGEIWDAT] [(Respondent)]

What were the total receipts from the business in [PYEAR]?

| |
|------------------|
| \$ 0 – 9,999,997 |
|------------------|

G11A. Business #[1-5]: [G7B] - [CYNAMF CYNAML]: [CYAQRTH], [CYFUHU], Age [AGEIWDAT] [(Respondent)]

What were the total operating expenses, not counting living expenses (in [PYEAR])?

| |
|------------------|
| \$ 0 – 9,999,997 |
|------------------|

G11CKPT. CAI Checkpoint: Whether G11 or G11A is Non-Response

| | | |
|------------------------------|---------------|---|
| 1. G11=DK, RF or G11A=DK, RF | 5. All Others | → Assign G11B=G11 minus G11A; Then GO TO G11F RULE |
| ↓ | | |

G11B. Business #[1-5]: [G7B] - [CYNAMF CYNAML]: [CYAQRTH], [CYFUHU], Age [AGEIWDAT] [(Respondent)]

(And) what was the net income from the business (in [PYEAR])?

- Receipts: [Don't Know / Refused / \$(G11)]
- Expenses: [Don't Know / Refused / \$(G11A)]

\$ -999,999 – 9,999,997

GO TO G11F RULE

SECTION_G.G7_G11[1-5].G11D_G11E[1-2] [1-5]=Which business; [1]=Current Head, [2]=Current Spouse/Partner
G11DAQSN. AQSN of Current Head (Spouse/Partner)

G11DCKPT. CAI Checkpoint: Whether Head (Spouse/Partner) Worked For This Corp But Did Not Report It

1. Worked For Corp But Didn't Report It (G9A=Yes & G9B<>Yes) 5. All Others → GO TO G11E RULE



G11D. Business #[1-5]: [G7B] - [CYNAMF CYNAML]: [CYAQRTH], [CYFUHU], Age [AGEIWDAT] [(Respondent)]

How much did [you / [HEAD / SP]] make at this business in [PYEAR]?

\$ 1 – 9,999,997

G11E RULE: Whether Spouse/Partner in FU

Spouse/Partner (CYAQRTH=201-222, CYFUHU=FU, FUMI) → Repeat G11DCKPT-G11D; Then GO TO G12 RULE

No Spouse/Partner



G12 RULE: Number of Businesses at G6

More Businesses → Repeat G7A-G11E RULE; Max=5; Then GO TO G12

No More Businesses



END G11D_G11E

END G7_G11

SECTION_G.G12_G46G[1-2] [1]=Current Head, [2]=Current Spouse/Partner
G12AQSN. AQSN of Current Head (Spouse/Partner)

Earnings

G12. [CYNAMF CYNAML]: [CYAQRTH], [CYFUHU], Age [AGEIWDAT] [(Respondent)]

Did [you / [HEAD / SP]] earn wages or salaries in [PYEAR] from working on any jobs [G9A=YES & G10 = UNINCORPORATED: besides the unincorporated business we have just talked about]?

(Let me remind you, the jobs we talked about were:)

[READ Employers Head worked for in \[PYEAR\]:](#)

[\[List of PYEAR Employers from EHC\]](#)

- IF necessary, review employment history and add: including wages or salaries from the job(s) we already talked about?

1. Yes → GO TO G13 5. No



G12CKPT2/G12CKPT2S. CAI Checkpoint: Whether Head (Spouse/Partner) Job Reported for PYEAR or No Job Reported but Head (Spouse/Partner) Worked For a Reported Incorporated Business

| | | |
|---|---|----------------------------|
| 1. PYEAR Job (BCWTRP1YEAR=1 Any Job) | 2. No PYEAR Job, Worked PYEAR For Corp (BCWTRP1YEAR=0 All Jobs & G9A=Yes & G10=Corp) | 5. All Others GO TO G16 |
| ↓ | | |

G12 HARD CHECK:

HEAD / SP [HAS A JOB IN EHC] [OR] [WORKED FOR AN INCORPORATED BUSINESS] IN [PYEAR] BUT HAS NO WAGES OR SALARY IN G12.

PROBE: (Were/Was) there any wage(s) or salary(s) from (this job/these jobs)?

If "YES", PRESS [Enter] or SELECT [Go To], to go to G12 & ENTER [Yes].

If "NO", SELECT [Suppress] to go to G12A & record explanation.

Yes → RETURN TO G12 No



G12A. [CYNAMF CYNAML]: [CYAQRTH], [CYFUHU], Age [AGEIWDATE] [(Respondent)]

How is it that [you / [HEAD / SP]] worked in [PYEAR], but did not receive earnings from it?

GO TO G16

G13. [CYNAMF CYNAML]: [CYAQRTH], [CYFUHU], Age [AGEIWDATE] [(Respondent)]

How much did [you / [HEAD / SP]] earn altogether from wages or salaries in [PYEAR], that is, before anything was deducted for taxes or other things?

G14. [CYNAMF CYNAML]: [CYAQRTH], [CYFUHU], Age [AGEIWDATE] [(Respondent)]

In addition to this, did [you / [HEAD / SP]] have any income from bonuses, overtime, tips, or commissions?

1. Yes → GO TO G16A 5. No → GO TO G17F

G16. [CYNAMF CYNAML]: [CYAQRTH], [CYFUHU], Age [AGEIWDATE] [(Respondent)]

Did [you / [HEAD / SP]] have any income from bonuses, overtime, tips, or commissions?

1. Yes 5. No → GO TO G18A



G16A. [CYNAMF CYNAML]: [CYAQRTH], [CYFUHU], Age [AGEIWDATE] [(Respondent)]

Which was that?

- ENTER all that apply
- PROBE: Any others?

| | | | | | |
|------------|-------------|----------|----------------|------------------|------------|
| 1. Bonuses | 2. Overtime | 3. Tips | 4. Commissions | 7. Other-specify | DK/RF |
| ASK G17A | ASK G17B | ASK G17C | ASK G17D | ASK G16B, G17E | GO TO G17F |

G17A. [CYNAMF CYNAML]: [CYAQRTH], [CYFUHU], Age [AGEIWDATE] [(Respondent)]

How much was from bonuses?

G17B. [CYNAMF CYNAML]: [CYAQRTH], [CYFUHU], Age [AGEIWDATE] [(Respondent)]

How much was from overtime?

G17C. [CYNAMF CYNAML]: [CYAQRTH], [CYFUHU], Age [AGEIWDATE] [(Respondent)]

How much was from tips?

\$ 1 – 999,997

G17D. [CYNAMF CYNAML]: [CYAQRTH], [CYFUHU], Age [AGEIWDATE] [(Respondent)]

How much was from commissions?

\$ 1 – 999,997

G16B. [CYNAMF CYNAML]: [CYAQRTH], [CYFUHU], Age [AGEIWDATE] [(Respondent)]

What was that other job-related income from?

String 500

G17E. [CYNAMF CYNAML]: [CYAQRTH], [CYFUHU], Age [AGEIWDATE] [(Respondent)]

How much was from other job related income?

\$ 1 – 999,997

G17F. [CYNAMF CYNAML]: [CYAQRTH], [CYFUHU], Age [AGEIWDATE] [(Respondent)]

Reported Incomes: [Wages/salaries, bonus, overtime, tips, commissions, other job-related income]

Did you tell me earlier about all the jobs that go with (this / these) income(s)?

(Let me remind you, the jobs we talked about were:)

[READ employers if needed](#)

[\[List of PYEAR Employers from EHC\]](#)

1. Yes, R reported all jobs that produced this income

→ GO TO G18A

5. No, R did not report all jobs that produced this income

↓

G17J1. [CYNAMF CYNAML]: [CYAQRTH], [CYFUHU], Age [AGEIWDATE] [(Respondent)]

Then I would like to ask you some questions now about the work [you / [HEAD / SP]] did for this income. Did [you / he / she] work for the federal, state or local government, a private company, or what?

1. Federal government

2. State government

3. Local government

4. Private non-government

5. Self-employed

7. Other-specify (G17J1SPEC. Specify (String 100))

G17J2. [CYNAMF CYNAML]: [CYAQRTH], [CYFUHU], Age [AGEIWDATE] [(Respondent)]

What was the name of that employer?

- **IF necessary:** This information will help us to process employment information you gave us. The name itself will never be released as part of data from the study.
- **IWER:** IF no employer name is given by R, ask for job title or anything that can help identify the job.

String 25

G17J3. [CYNAMF CYNAML]: [CYAQRTH], [CYFUHU], Age [AGEIWDATE] [(Respondent)]

What sort of work did [you / he / she] do?

- **DO NOT PROBE**

String 500

G17J3B. [CYNAMF CYNAML]: [CYAQRTH], [CYFUHU], Age [AGEIWDATE] [(Respondent)]

What kind of business or industry was that in?

- **DO NOT PROBE**

String 500

G17J3C. [CYNAMF CYNAML]: [CYAQRTH], [CYFUHU], Age [AGEIWDATE] [(Respondent)]
 What was the official title of [your / [HEAD / SP]]'s job? (The title that [your / his / her] employer used.)

- DO NOT PROBE

String 200

G17J4. [CYNAMF CYNAML]: [CYAQRTH], [CYFUHU], Age [AGEIWDATE] [(Respondent)]
 And, how many weeks did [you / he / she] work at this in [PYEAR]?

1 – 52

G17J5. [CYNAMF CYNAML]: [CYAQRTH], [CYFUHU], Age [AGEIWDATE] [(Respondent)]
 On average, how many hours a week did [you / he / she] work?

- ROUND DOWN for fractions less than ½ (0.5)
- ROUND UP for fractions ½ (0.5) or more

1 – 112

G17J6MO. [CYNAMF CYNAML]: [CYAQRTH], [CYFUHU], Age [AGEIWDATE] [(Respondent)]
 In what month and year did [you / he / she] start this work?

- SELECT Month and [Enter] to go to next screen for year
- IF NECESSARY: What would be your best estimate?

| | | | | | |
|------------|-------------|--------------|-------------|--------------|--------------|
| 1. January | 2. February | 3. March | 4. April | 5. May | 6. June |
| 7. July | 8. August | 9. September | 10. October | 11. November | 12. December |
| 21. Winter | 22. Spring | 23. Summer | 24. Fall | | |

G17J6YR. [CYNAMF CYNAML]: [CYAQRTH], [CYFUHU], Age [AGEIWDATE] [(Respondent)]
 The month entered is: [G17J6MO]

- ENTER the year below
- 9997 Before [P2YEAR], DK exact year

1901 – [PYEAR] 9997. Before [P2YEAR], DK Exact Year

G17J7. [CYNAMF CYNAML]: [CYAQRTH], [CYFUHU], Age [AGEIWDATE] [(Respondent)]
 In which months during [PYEAR] [were you / was [he / she]] working at it?

- ENTER all that apply
- PROBE: Any others?

| | | | | | |
|------------|-------------|--------------|-------------|--------------|--------------|
| 1. January | 2. February | 3. March | 4. April | 5. May | 6. June |
| 7. July | 8. August | 9. September | 10. October | 11. November | 12. December |
| 13. All | | | | | |

G17J8. [CYNAMF CYNAML]: [CYAQRTH], [CYFUHU], Age [AGEIWDATE] [(Respondent)]
 [Have you / Has [he / she]] stopped this work?

1. Yes 5. No → GO TO G18A

↓

G17J9MO. [CYNAMF CYNAML]: [CYAQRTH], [CYFUHU], Age [AGEIWDATE] [(Respondent)]
 In what month and year was that?

- SELECT Month and [Enter] to go to next screen for year
- IF NECESSARY: What would be your best estimate?

| | | | | |
|--------------|--------------|------------|--------------|-------------|
| 1. January | 2. February | 3. March | 4. April | 5. May |
| 6. June | 7. July | 8. August | 9. September | 10. October |
| 11. November | 12. December | 21. Winter | 22. Spring | 23. Summer |
| | | 24. Fall | | |

G17J9YR. [CYNAMF CYNAML]: [CYAQRTH], [CYFUHU], Age [AGEIWDATE] [(Respondent)]

The month entered is: [G17J9MO]

- ENTER the year below
9996 [PYEAR] or [CYEAR] and DK which

[PYEAR] [CYEAR] 9996. [PYEAR] - [CYEAR], DK Which Year

G17J10. [CYNAMF CYNAML]: [CYAQRTH], [CYFUHU], Age [AGEIWDATE] [(Respondent)]

What happened - did [your / his / her] employer close or go out of business, did [you / he / she] quit, or what?

String 500

Professional Practice or Trade

G18A. [CYNAMF CYNAML]: [CYAQRTH], [CYFUHU], Age [AGEIWDATE] [(Respondent)]

I'm going to read you a list of other sources of income [you / [HEAD / SP]] might have had. Did [you / [HEAD / SP]] receive any other income in [PYEAR] from professional practice or trade?

1. Yes 5. No → GO TO G22CKPT

↓

G19A. [CYNAMF CYNAML]: [CYAQRTH], [CYFUHU], Age [AGEIWDATE] [(Respondent)]

How much was it?

- ENTER amount here, then SELECT unit of time on next screen (Day, Week, Two weeks, Month, Year)

\$ 1 – 9,999,997 DK/RF → GO TO G20A

↓

G19APER. The amount entered is: [G19A] per ___

- SELECT the unit of time below

2. Day 3. Week 4. Two weeks 5. Month 6. Year

7. Other-specify (G19APERSPEC. Specify. (String 100))

G20A. [CYNAMF CYNAML]: [CYAQRTH], [CYFUHU], Age [AGEIWDATE] [(Respondent)]

During which months of [PYEAR] did [you / he / she] get this income?

- ENTER all that apply
- PROBE: Any others?

1. January 2. February 3. March 4. April 5. May 6. June
7. July 8. August 9. September 10. October 11. November 12. December 13. All

G21ACKPT. [CYNAMF CYNAML]: [CYAQRTH], [CYFUHU], Age [AGEIWDATE] [(Respondent)]

Reported Incomes: Professional Practice or Trade

Did you tell me earlier about all the jobs that go with this income?

(Let me remind you, the jobs we talked about were:)

READ employers if needed

[List of PYEAR Employers from EHC]

1. Yes, R reported all jobs that produced this income → GO TO G22CKPT

5. No, R did not report all jobs that produced this income

↓

G18AJ1. [CYNAMF CYNAML]: [CYAQRTH], [CYFUHU], Age [AGEIWDATE] [(Respondent)]

Then I would like to ask you some questions now about the work [you / he / she] did for this income. Did [you / he / she] work for the federal, state or local government, a private company, or what?

1. Federal government 2. State government 3. Local government

4. Private non-government 5. Self-employed 7. Other-specify (G18AJ1SPEC. Specify (String 100))

G18AJ2. [CYNAMF CYNAML]: [CYAQRTH], [CYFUHU], Age [AGEIWDATE] [(Respondent)]

What was the name of that employer?

- **IF NECESSARY:** This information will help us to process employment information you gave us. The name itself will never be released as part of data from the study.
- **IWER:** IF no employer name is given by R, ask for job title or anything that can help identify the job.

String 25

G18AJ3. [CYNAMF CYNAML]: [CYAQRTH], [CYFUHU], Age [AGEIWDATE] [(Respondent)]

What sort of work did [you / he / she] do?

- **DO NOT PROBE**

String 500

G18AJ3B. [CYNAMF CYNAML]: [CYAQRTH], [CYFUHU], Age [AGEIWDATE] [(Respondent)]

What kind of business or industry was that in?

- **DO NOT PROBE**

String 500

G18AJ3C. [CYNAMF CYNAML]: [CYAQRTH], [CYFUHU], Age [AGEIWDATE] [(Respondent)]

What was the official title of [your / [HEAD / SP]'s] job? (The title that [your / his / her] employer used.)

- **DO NOT PROBE**

String 200

G18AJ4. [CYNAMF CYNAML]: [CYAQRTH], [CYFUHU], Age [AGEIWDATE] [(Respondent)]

And, how many weeks did [you / he / she] work at this in [PYEAR]?

1 – 52

G18AJ5. [CYNAMF CYNAML]: [CYAQRTH], [CYFUHU], Age [AGEIWDATE] [(Respondent)]

On average, how many hours a week did [you / he / she] work?

- **ROUND DOWN** for fractions less than $\frac{1}{2}$ (0.5)
- **ROUND UP** for fractions $\frac{1}{2}$ (0.5) or more

1 – 112

G18AJ6MO. [CYNAMF CYNAML]: [CYAQRTH], [CYFUHU], Age [AGEIWDATE] [(Respondent)]

In what month and year did [you / he / she] start this work?

- **SELECT Month and [Enter] to go to next screen for year**
- **IF NECESSARY:** What would be your best estimate?

| | | | | | |
|------------|-------------|--------------|-------------|--------------|--------------|
| 1. January | 2. February | 3. March | 4. April | 5. May | 6. June |
| 7. July | 8. August | 9. September | 10. October | 11. November | 12. December |
| 21. Winter | 22. Spring | 23. Summer | 24. Fall | | |

G18AJ6YR. [CYNAMF CYNAML]: [CYAQRTH], [CYFUHU], Age [AGEIWDATE] [(Respondent)]

The month entered is: [G18AJ6MO]

- **ENTER** the year below
9997 Before [P2YEAR], DK exact year

1901 – [PYEAR] 9997. Before [P2YEAR], DK Exact Year

G18AJ7. [CYNAMF CYNAML]: [CYAQRTH], [CYFUHU], Age [AGEIWDATE] [(Respondent)]

In which months during [PYEAR] [were you / was [he / she]] working at it?

- ENTER all that apply
- PROBE: Any others?

| | | | | | | |
|------------|-------------|--------------|-------------|--------------|--------------|---------|
| 1. January | 2. February | 3. March | 4. April | 5. May | 6. June | |
| 7. July | 8. August | 9. September | 10. October | 11. November | 12. December | 13. All |

G18AJ8. [CYNAMF CYNAML]: [CYAQRTH], [CYFUHU], Age [AGEIWDATE] [(Respondent)]

[Have you / Has [he / she]] stopped this work?

1. Yes 5. No → GO TO G22CKPT



G18AJ9MO. [CYNAMF CYNAML]: [CYAQRTH], [CYFUHU], Age [AGEIWDATE] [(Respondent)]

In what month and year was that?

- SELECT Month and [Enter] to go to next screen for year
- IF NECESSARY: What would be your best estimate?

| | | | | | |
|--------------|--------------|------------|--------------|-------------|----------|
| 1. January | 2. February | 3. March | 4. April | 5. May | |
| 6. June | 7. July | 8. August | 9. September | 10. October | |
| 11. November | 12. December | 21. Winter | 22. Spring | 23. Summer | 24. Fall |

G18AJ9YR. [CYNAMF CYNAML]: [CYAQRTH], [CYFUHU], Age [AGEIWDATE] [(Respondent)]

The month entered is: [G18AJ9MO]

- ENTER the year below
- 9996 [PYEAR] or [CYEAR] and DK which

[PYEAR] [CYEAR] 9996. [PYEAR] - [CYEAR], DK Which Year

G18AJ10. [CYNAMF CYNAML]: [CYAQRTH], [CYFUHU], Age [AGEIWDATE] [(Respondent)]

What happened – did it go out of business, did [you / he / she] quit, or what?

String 500

Other Earnings

G22CKPT. CAI Checkpoint: Number of PYEAR Jobs Reported for Head (Spouse/Partner)

| | | |
|---------------------------------|---------------|--------------|
| 1. More Than One Job in [PYEAR] | 5. All Others | → GO TO G25A |
|---------------------------------|---------------|--------------|

↓

G23. [CYNAMF CYNAML]: [CYAQRTH], [CYFUHU], Age [AGEIWDATE] [(Respondent)]

Did you include [your / [HEAD / SP]'s] earnings from all of [your / his / her] jobs in the amounts we just talked about?

1. Yes → GO TO G25A 5. No



G24. [CYNAMF CYNAML]: [CYAQRTH], [CYFUHU], Age [AGEIWDATE] [(Respondent)]

How much did [you / [HEAD / SP]] earn from (that job/those other jobs) in [PYEAR]?

\$ 1 – 9,999,997

Rent

G25A. [CYNAMF CYNAML]: [CYAQRTH], [CYFUHU], Age [AGEIWDATE] [(Respondent)]

Did [you / [HEAD / SP]] receive any (other) income in [PYEAR] from rent?

1. Yes 5. No → GO TO G25B



G26A. [CYNAMF CYNAML]: [CYAQRTH], [CYFUHU], Age [AGEIWDATE] [(Respondent)]

How much was it?

- ENTER amount here, then SELECT unit of time on next screen (Week, Two weeks, Month, Year)

\$ 1 – 999,997 DK/RF → GO TO G26A1CKPT



G26APER. The amount entered is: [G26A] per ___

- SELECT the unit of time below

3. Week 4. Two weeks 5. Month 6. Year

7. Other-specify (G26APERSPEC. Specify. (String 100))

G26A1CKPT. CAI Checkpoint: Whether Spouse/Partner in FU

| | |
|--|-----------------------------------|
| 1. Spouse/Partner (CYAQRTH=201-222, CYFUHU=FU, FUMI) | 5. No Spouse/Partner → GO TO G27A |
| Head Loop | Spouse/Partner Loop |
| ↓ | |
| GO TO G26A3CKPT | |

G26A2. [CYNAMF CYNAML]: [CYAQRTH], [CYFUHU], Age [AGEIWDATE] [(Respondent)]

Does that include [your / [SP]'s] share?

1. Yes 5. No

G26A3CKPT.CAI Checkpoint: Whether Head Reported Rent

| | | |
|---|--------------|---|
| 1. Spouse/Partner Loop: Head Rent (G25A[1]=Yes) | 2. Head Loop | 3. Spouse/Partner Loop: No Head Rent (G25A[1]<>Yes) |
| ↓ | | GO TO G27A |

G26A3. [CYNAMF CYNAML]: [CYAQRTH], [CYFUHU], Age [AGEIWDATE] [(Respondent)]

Is that in addition to the amount you reported for [[HEAD] / yourself]?

1. Yes 5. No

G27A. [CYNAMF CYNAML]: [CYAQRTH], [CYFUHU], Age [AGEIWDATE] [(Respondent)]

During which months of [PYEAR] did [you / [HEAD / SP]] get this income?

- ENTER all that apply
- PROBE: Any others?

| | | | | | | |
|------------|-------------|--------------|-------------|--------------|--------------|---------|
| 1. January | 2. February | 3. March | 4. April | 5. May | 6. June | |
| 7. July | 8. August | 9. September | 10. October | 11. November | 12. December | 13. All |

Dividends

G25B. [CYNAMF CYNAML]: [CYAQRTH], [CYFUHU], Age [AGEIWDATE] [(Respondent)]

(Did [you / [HEAD / SP]] receive any other income in [PYEAR]...)

From dividends?

1. Yes 5. No → GO TO G25C



G26B. [CYNAMF CYNAML]: [CYAQRTH], [CYFUHU], Age [AGEIWDATE] [(Respondent)]

How much was it?

- ENTER amount here, then SELECT unit of time on next screen (Month, Year)

\$ 1 – 999,997 DK/RF → GO TO G26B1CKPT



G26BPER. The amount entered is: [G26B] per ___

- SELECT the unit of time below

5. Month 6. Year 7. Other-specify (G26BPERSPEC. Specify. (String 100))

G26B1CKPT. CAI Checkpoint: Whether Spouse/Partner in FU

| | |
|--|-----------------------------------|
| 1. Spouse/Partner (CYAQRTH=201-222, CYFUHU=FU, FUMI) | 5. No Spouse/Partner → GO TO G27B |
| Head Loop | Spouse/Partner Loop |
| ↓ | GO TO G26B3CKPT |

G26B2. [CYNAMF CYNAML]: [CYAQRTH], [CYFUHU], Age [AGEIWDATE] [(Respondent)]

Does that include [your / [SP]'s] dividends?

1. Yes 5. No

G26B3CKPT.CAI Checkpoint: Whether Head Reported Dividends

| | | |
|--|--------------|--|
| 1. Spouse/Partner Loop: Head Dividends (G25B[1]=Yes) | 2. Head Loop | 3. Spouse/Partner Loop: No Head Dividends (G25B[1]<>Yes) |
| ↓ | GO TO G27B | |

G26B3. [CYNAMF CYNAML]: [CYAQRTH], [CYFUHU], Age [AGEIWDATE] [(Respondent)]

Is that in addition to the amount you reported for [[HEAD] / yourself]?

1. Yes 5. No

G27B. [CYNAMF CYNAML]: [CYAQRTH], [CYFUHU], Age [AGEIWDATE] [(Respondent)]

During which months of [PYEAR] did [you / [HEAD / SP]] get this income?

- ENTER all that apply

- PROBE: Any others?

1. January 2. February 3. March 4. April 5. May 6. June
7. July 8. August 9. September 10. October 11. November 12. December 13. All

Interest

G25C. [CYNAMF CYNAML]: [CYAQRTH], [CYFUHU], Age [AGEIWDATE] [(Respondent)]

(Did [you / [HEAD / SP]] receive any other income in [PYEAR]...)

From interest?

1. Yes 5. No → GO TO G25D



G26C. [CYNAMF CYNAML]: [CYAQRTH], [CYFUHU], Age [AGEIWDATE] [(Respondent)]

How much was it?

- ENTER amount here, then SELECT unit of time on next screen (Week, Two weeks, Month, Year)

\$ 1 – 999,997 DK/RF → GO TO G26C1CKPT



G26CPER. The amount entered is: [G26C] per __

- SELECT the unit of time below

3. Week 4. Two weeks 5. Month 6. Year

7. Other-specify (G26CPERSPEC. Specify. (String 100))

G26C1CKPT. CAI Checkpoint: Whether Spouse/Partner in FU

| | |
|--|-----------------------------------|
| 1. Spouse/Partner (CYAQRTH=201-222, CYFUHU=FU, FUMI) | 5. No Spouse/Partner → GO TO G27C |
| Head Loop | Spouse/Partner Loop |
| ↓ | GO TO G26C3CKPT |

G26C2. [CYNAMF CYNAML]: [CYAQRTH], [CYFUHU], Age [AGEIWDATE] [(Respondent)]

Does that include [your / [SP]'s] interest?

1. Yes 5. No

G26C3CKPT. CAI Checkpoint: Whether Head Reported Interest

| | | |
|---|--------------|---|
| 1. Spouse/Partner Loop: Head Interest (G25C[1]=Yes) | 2. Head Loop | 3. Spouse/Partner Loop: No Head Interest (G25C[1]<>Yes) |
| ↓ | | GO TO G27C |

G26C3. [CYNAMF CYNAML]: [CYAQRTH], [CYFUHU], Age [AGEIWDATE] [(Respondent)]

Is that in addition to the amount you reported for [[HEAD] / yourself]?

1. Yes 5. No

G27C. [CYNAMF CYNAML]: [CYAQRTH], [CYFUHU], Age [AGEIWDATE] [(Respondent)]

During which months of [PYEAR] did [you / [HEAD / SP]] get this income?

- ENTER all that apply

- PROBE: Any others?

| | | | | | | |
|------------|-------------|--------------|-------------|--------------|--------------|---------|
| 1. January | 2. February | 3. March | 4. April | 5. May | 6. June | |
| 7. July | 8. August | 9. September | 10. October | 11. November | 12. December | 13. All |

Trust Funds and Royalties

G25D. [CYNAMF CYNAML]: [CYAQRTH], [CYFUHU], Age [AGEIWDATE] [(Respondent)]

(Did [you / [HEAD / SP]] receive any other income in [PYEAR]...)

From trust funds and royalties?

1. Yes 5. No → GO TO G25ECKPT



G26D. [CYNAMF CYNAML]: [CYAQRTH], [CYFUHU], Age [AGEIWDATE] [(Respondent)]

How much was it?

- ENTER amount here, then SELECT unit of time on next screen (Month, Year)

\$ 1 – 999,997 DK/RF → GO TO G27D



G26DPER. The amount entered is: [G26D] per __

- SELECT the unit of time below

5. Month 6. Year 7. Other-specify (G26DPERSPEC. Specify. (String 100))

G27D. [CYNAMF CYNAML]: [CYAQRTH], [CYFUHU], Age [AGEIWDATE] [(Respondent)]

During which months of [PYEAR] did [you / [HEAD / SP]] get this income?

- ENTER all that apply
- PROBE: Any others?

| | | | | | | |
|------------|-------------|--------------|-------------|--------------|--------------|---------|
| 1. January | 2. February | 3. March | 4. April | 5. May | 6. June | |
| 7. July | 8. August | 9. September | 10. October | 11. November | 12. December | 13. All |

TANF

G25ECKPT. CAI Checkpoint: Head (Spouse/Partner) PYEAR Wages/Salary

| | | |
|--|---------------|-----------------|
| 1. PYEAR Wages/Salary \$25,000 or Less (G13 ≤ \$25,000, DK/RF) | 5. All Others | → GO TO G31CKPT |
|--|---------------|-----------------|



G25E. [CYNAMF CYNAML]: [CYAQRTH], [CYFUHU], Age [AGEIWDATE] [(Respondent)]

(Did [you / [HEAD / SP]] receive any income in [PYEAR]...)

From TANF (Temporary Assistance for Needy Families) [PYSTATERESIDE<>FC/DK/RF: or [STATEPROG]]?

1. Yes 5. No → GO TO G25F



G26E. [CYNAMF CYNAML]: [CYAQRTH], [CYFUHU], Age [AGEIWDATE] [(Respondent)]

How much was it?

- ENTER amount here, then SELECT unit of time on next screen (Two weeks, Month, Year)

\$ 1 – 999,997 DK/RF → GO TO G27E



G26EPPER. The amount entered is: [G26E] per __

- SELECT the unit of time below

4. Two weeks 5. Month 6. Year 7. Other-specify (G26EPPERPEC. Specify. (String 100))

G27E. [CYNAMF CYNAML]: [CYAQRTH], [CYFUHU], Age [AGEIWDATE] [(Respondent)]

During which months of [PYEAR] did [you / [HEAD / SP]] get this income?

- ENTER all that apply
- PROBE: Any others?

| | | | | | | |
|------------|-------------|--------------|-------------|--------------|--------------|---------|
| 1. January | 2. February | 3. March | 4. April | 5. May | 6. June | |
| 7. July | 8. August | 9. September | 10. October | 11. November | 12. December | 13. All |

G27EE. [CYNAMF CYNAML]: [CYAQRTH], [CYFUHU], Age [AGEIWDATE] [(Respondent)]

Who in the family was covered by this?

- ENTER all that apply
- PROBE: Any others?

1 – 24. [CYNAMF CYNAML], [CYAQRTH], [CYFUHU] *AQSN list of FU Members w/FUHU=FU, FUMI≤PYEAR, MO≥PYEAR, DECD≥PYEAR, MILIT, EDUC, HLTH, OTHR)*

Supplemental Security Income

G25F. [CYNAMF CYNAML]: [CYAQRTH], [CYFUHU], Age [AGEIWDATE] [(Respondent)]

(Did [you / [HEAD / SP]] receive any income in [PYEAR]...)

From Supplemental Security Income?

- SSI (Supplemental Security Income) is **not** Social Security, nor is it Social Security Disability Insurance (SSDI), although the Social Security Administration administers the program and a person can receive both. See F1-Help for more information.

1. Yes 5. No → GO TO G25G



G25FF. [CYNAMF CYNAML]: [CYAQRTH], [CYFUHU], Age [AGEIWDATE] [(Respondent)]

Did [you / [HEAD / SP]] receive it for [yourself / himself / herself], or for someone else?

1. Self → GO TO G26F 2. Someone else 3. Both DK/RF → GO TO G26F



G25FFF. [CYNAMF CYNAML]: [CYAQRTH], [CYFUHU], Age [AGEIWDATE] [(Respondent)]

Let's talk about the other person's Supplemental Security when we talk about their income.

- ENTER [1] to continue

1. Continue

G25F4 Rule: Whether SSI for Someone Else or Both

Someone Else (G25FF=2) → GO TO G25G Both (G25FF=3)



G26F. [CYNAMF CYNAML]: [CYAQRTH], [CYFUHU], Age [AGEIWDATE] [(Respondent)]

How much was [G25FF=SELF: it / ALL OTHERS: the Supplemental Security Income [you / he / she] received for [yourself / himself / herself]]?

- ENTER amount here, then SELECT unit of time on next screen (Month, Year)

\$ 1 – 999,997 DK/RF → GO TO G27F



G26FPER. The amount entered is: [G26F] per __

- SELECT the unit of time below

5. Month 6. Year 7. Other-specify (G26FPERSPEC. Specify. (String 100))

G27F. [CYNAMF CYNAML]: [CYAQRTH], [CYFUHU], Age [AGEIWDATE] [(Respondent)]

During which months of [PYEAR] did [you / [HEAD / SP]] get this income?

- ENTER all that apply
- PROBE: Any others?

| | | | | | | |
|------------|-------------|--------------|-------------|--------------|--------------|---------|
| 1. January | 2. February | 3. March | 4. April | 5. May | 6. June | |
| 7. July | 8. August | 9. September | 10. October | 11. November | 12. December | 13. All |

Other Welfare

G25G. [CYNAMF CYNAML]: [CYAQRTH], [CYFUHU], Age [AGEIWDATE] [(Respondent)]

(Did [you / [HEAD / SP]] receive any income in [PYEAR]...)

From other welfare?

1. Yes 5. No → GO TO G31CKPT

↓

G26G. [CYNAMF CYNAML]: [CYAQRTH], [CYFUHU], Age [AGEIWDATE] [(Respondent)]

How much was it?

- ENTER amount here, then SELECT unit of time on next screen (Week, Two weeks, Month, Year)

\$ 1 – 999,997 DK/RF → GO TO G27G

↓

G26GPER. The amount entered is: [G26G] per __

- SELECT the unit of time below

3. Week 4. Two weeks 5. Month 6. Year

7. Other-specify (G26GPERSPEC. Specify. (String 100))

G27G. [CYNAMF CYNAML]: [CYAQRTH], [CYFUHU], Age [AGEIWDATE] [(Respondent)]

During which months of [PYEAR] did [you / [HEAD / SP]] get this income?

- ENTER all that apply
- PROBE: Any others?

| | | | | | | |
|------------|-------------|--------------|-------------|--------------|--------------|---------|
| 1. January | 2. February | 3. March | 4. April | 5. May | 6. June | |
| 7. July | 8. August | 9. September | 10. October | 11. November | 12. December | 13. All |

Social Security

G31CKPT. CAI Checkpoint: Whether Spouse/Partner's Social Security Reported During Head's Loop

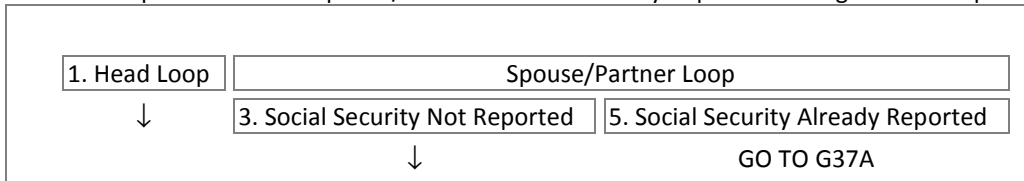

G31. [CYNAMF CYNAML]: [CYAQRTH], [CYFUHU], Age [AGEIWDATE] [(Respondent)]

Did [HEAD LOOP: [you / [HEAD]] [or anyone else in the family there] / SP LOOP: Did [you / [SP]] receive any income in [PYEAR] from Social Security, such as disability, retirement or survivor's benefits?

- [HEAD LOOP: All Social Security received by any FU member must be reported here]

1. Yes 5. No → GO TO G37A

↓

G32 Rule: Number of FU Members

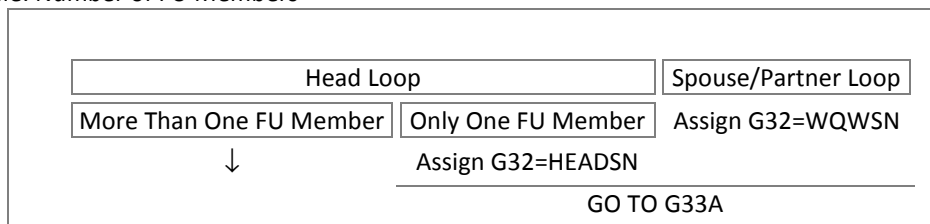

G32. [CYNAMF CYNAML]: [CYAQRTH], [CYFUHU], Age [AGEIWDATE] [(Respondent)]

Who was that?

- ENTER all that apply
- PROBE: Any others?

1 – 24. [CYNAMF CYNAML], [CYAQRTH], [CYFUHU] DK/RF → GO TO G37A

AQSN list of HEAD if FUHU=FU, FUMI; SP if FUHU=FU, FUMI;
OFUM if FUHU=FU, FUMI≤PYEAR, MO≥PYEAR, DECD≥PYEAR



SECTION_G.G12_G46G[1-2].G33_G35[1-24] [1-24]=AQSN of FU Member

G33A. [G32]: [CYAQRTH], [CYFUHU], Age [AGEIWDATE] [(Respondent)]

([First / Next],) let me ask about [your / [G32]'s] Social Security. Was that disability, retirement, survivor's benefits, or what?

- ENTER all that apply
- PROBE: Any others?

1. Disability 2. Retirement 3. Survivor's benefits 5. Dependent of disabled recipient
6. Dependent of retired recipient 7. Other-specify (G33ASPEC. Specify. (String 100))

G34. [G32]: [CYAQRTH], [CYFUHU], Age [AGEIWDATE] [(Respondent)]

How much was the total amount from Social Security? [2+ SOCSEC INCOMES: Please include all amounts from all types of Social Security [you / [G32]] received in [PYEAR].]

- ENTER amount here, then SELECT unit of time on next screen (Month, Year)

\$ 1 – 999,997 DK/RF → GO TO G35



G34PER. The amount entered is: [G34] per ___

- SELECT the unit of time below

5. Month 6. Year 7. Other-specify (G34PERSPEC. Specify. (String 100))

G35. [G32]: [CYAQRTH], [CYFUHU], Age [AGEIWDATE] [(Respondent)]

During which months of [PYEAR] did [you / [G32]] get this income? [(This includes all types of Social Security [you / [G32]] received in [PYEAR].)]

- ENTER all that apply
- PROBE: Any others?

1. January 2. February 3. March 4. April 5. May 6. June
7. July 8. August 9. September 10. October 11. November 12. December 13. All

G35 Rule: Whether More FU Members Reported at G32

More FU Members → Repeat G33A-G35; Max=24;
Then GO TO G37A

No More FU Members



END G33_G35

VA Pensions

G37A. [CYNAMF CYNAML]: [CYAQRTH], [CYFUHU], Age [AGEIWDATE] [(Respondent)]

Did [you / [HEAD / SP]] receive any income in [PYEAR] from the Veterans Administration for a servicemen's, [MALE CYAQRTH=101, 201, 221: (widow's,) / FEMALE CYAQRTH=102, 202, 222: widow's,] or survivor's pension, service disability, or the GI bill?

- ENTER all that apply
- PROBE: Any others?

| | |
|--|---|
| 1. Yes, servicemen's, widow's, or survivor's pension | 2. Yes, service disability |
| 3. Yes, GI bill | 4. Yes, other-specify (G37ASPEC. Specify. (String 100)) |
| 5. No → GO TO G40 | |



G38. [CYNAMF CYNAML]: [CYAQRTH], [CYFUHU], Age [AGEIWDATE] [(Respondent)]

How much was the total amount? [2+ VA INCOMES: Please include all amounts from all types of VA (Veterans Administration) income [you / he / she] received in [PYEAR].]

- ENTER amount here, then SELECT unit of time on next screen (Month, Year)

| | | |
|----------------|-------|-------------|
| \$ 1 – 999,997 | DK/RF | → GO TO G39 |
|----------------|-------|-------------|



G38PER. The amount entered is: [G38] per ___

- SELECT the unit of time below

| | | |
|----------|---------|--|
| 5. Month | 6. Year | 7. Other-specify (G38PERSPEC. Specify. (String 100)) |
|----------|---------|--|

G39. [CYNAMF CYNAML]: [CYAQRTH], [CYFUHU], Age [AGEIWDATE] [(Respondent)]

During which months of [PYEAR] did [you / [HEAD / SP]] get this income? [(This includes all types of VA (Veterans Administration) income [you / he / she] received in [PYEAR].)]

- ENTER all that apply
- PROBE: Any others?

| | | | | | | |
|------------|-------------|--------------|-------------|--------------|--------------|---------|
| 1. January | 2. February | 3. March | 4. April | 5. May | 6. June | |
| 7. July | 8. August | 9. September | 10. October | 11. November | 12. December | 13. All |

Other Retirement

G40. [CYNAMF CYNAML]: [CYAQRTH], [CYFUHU], Age [AGEIWDATE] [(Respondent)]

Did [you / [HEAD / SP]] receive any income in [PYEAR] from other retirement pay, pensions, I.R.A.s (Individual Retirement Account) or annuities?

- ENTER all that apply
- PROBE: Any others?

| | | | | |
|----------------------------------|-------------------|-----------------------|-----------------|-------|
| 1. Yes, retirement pay, pensions | 2. Yes, annuities | 3. Yes, other-specify | 4. Yes, I.R.A.s | 5. No |
|----------------------------------|-------------------|-----------------------|-----------------|-------|

ASK G41A-G42A, G43

ASK G41B-G42B, G43

ASK G41C-G42C, G43

ASK G41D-G42D, G43

GO TO G44A

G40=Retirement Pay, Pensions

G41A. [CYNAMF CYNAML]: [CYAQRTH], [CYFUHU], Age [AGEIWDATE] [(Respondent)]

How much was from retirement pay or pensions?

- ENTER amount here, then SELECT unit of time on next screen (Month, Year)

| | | |
|----------------|-------|--------------|
| \$ 1 – 999,997 | DK/RF | → GO TO G42A |
|----------------|-------|--------------|



G41APER. The amount entered is: [G41A] per ___

- SELECT the unit of time below

| | | |
|----------|---------|---|
| 5. Month | 6. Year | 7. Other-specify (G41APERSPEC. Specify. (String 100)) |
|----------|---------|---|

G42A. [CYNAMF CYNAML]: [CYAQRTH], [CYFUHU], Age [AGEIWDATE] [(Respondent)]

During which months of [PYEAR] did [you / he / she] get this income?

- ENTER all that apply
- PROBE: Any others?

| | | | | | | |
|------------|-------------|--------------|-------------|--------------|--------------|---------|
| 1. January | 2. February | 3. March | 4. April | 5. May | 6. June | |
| 7. July | 8. August | 9. September | 10. October | 11. November | 12. December | 13. All |

G40=Annuities

G41B. [CYNAMF CYNAML]: [CYAQRTH], [CYFUHU], Age [AGEIWDATE] [(Respondent)]

How much was from annuities?

- ENTER amount here, then SELECT unit of time on next screen (Month, Year)

\$ 1 – 999,997 DK/RF → GO TO G42B



G41BPER. The amount entered is: [G41B] per __

- SELECT the unit of time below

| | | |
|----------|---------|---|
| 5. Month | 6. Year | 7. Other-specify (G41BPERSPEC. Specify. (String 100)) |
|----------|---------|---|

G42B. [CYNAMF CYNAML]: [CYAQRTH], [CYFUHU], Age [AGEIWDATE] [(Respondent)]

During which months of [PYEAR] did [you / [HEAD / SP]] get this income?

- ENTER all that apply
- PROBE: Any others?

| | | | | | | |
|------------|-------------|--------------|-------------|--------------|--------------|---------|
| 1. January | 2. February | 3. March | 4. April | 5. May | 6. June | |
| 7. July | 8. August | 9. September | 10. October | 11. November | 12. December | 13. All |

G40=Other

G41C. [CYNAMF CYNAML]: [CYAQRTH], [CYFUHU], Age [AGEIWDATE] [(Respondent)]

How much was the other (retirement) income?

- ENTER amount here, then SELECT unit of time on next screen (Month, Year)

\$ 1 – 999,997 DK/RF → GO TO G41C1



G41CPER. The amount entered is: [G41C] per __

- SELECT the unit of time below

| | | |
|----------|---------|---|
| 5. Month | 6. Year | 7. Other-specify (G41CPERSPEC. Specify. (String 100)) |
|----------|---------|---|

G41C1. [CYNAMF CYNAML]: [CYAQRTH], [CYFUHU], Age [AGEIWDATE] [(Respondent)]

What was that (other retirement income) from?

String 200

G42C. [CYNAMF CYNAML]: [CYAQRTH], [CYFUHU], Age [AGEIWDATE] [(Respondent)]

During which months of [PYEAR] did [you / he / she] get this income?

- ENTER all that apply
- PROBE: Any others?

| | | | | | | |
|------------|-------------|--------------|-------------|--------------|--------------|---------|
| 1. January | 2. February | 3. March | 4. April | 5. May | 6. June | |
| 7. July | 8. August | 9. September | 10. October | 11. November | 12. December | 13. All |

G40=IRA

G41D. [CYNAMF CYNAML]: [CYAQRTH], [CYFUHU], Age [AGEIWDATE] [(Respondent)]

How much was from I.R.A.s (Individual Retirement Account)?

- ENTER amount here, then SELECT unit of time on next screen (Month, Year)

 → GO TO G42D

G41DPER. The amount entered is: [G41D] per ___

- SELECT the unit of time below

G42D. [CYNAMF CYNAML]: [CYAQRTH], [CYFUHU], Age [AGEIWDATE] [(Respondent)]

During which months of [PYEAR] did [you / he / she] get this income?

- ENTER all that apply
- PROBE: Any others?

| | | | | | | |
|------------|-------------|--------------|-------------|--------------|--------------|---------|
| 1. January | 2. February | 3. March | 4. April | 5. May | 6. June | |
| 7. July | 8. August | 9. September | 10. October | 11. November | 12. December | 13. All |

G43. [CYNAMF CYNAML]: [CYAQRTH], [CYFUHU], Age [AGEIWDATE] [(Respondent)]

(Not including Veterans Administration pensions,) how many different pensions, I.R.A.s (Individual Retirement Account) or annuities did [you / [HEAD / SP]] receive income from in [PYEAR]?

- FOR 7 or more, ENTER [7]

Unemployment Compensation

G44A. [CYNAMF CYNAML]: [CYAQRTH], [CYFUHU], Age [AGEIWDATE] [(Respondent)]

Did [you / [HEAD / SP]] receive any income in [PYEAR] from unemployment compensation?

 → GO TO G44B

G45A. [CYNAMF CYNAML]: [CYAQRTH], [CYFUHU], Age [AGEIWDATE] [(Respondent)]

How much was it?

- ENTER amount here, then SELECT unit of time on next screen (Week, Two weeks, Month, Year)

 → GO TO G46A

G45APER. The amount entered is: [G45A] per ___

- SELECT the unit of time below

G46A. [CYNAMF CYNAML]: [CYAQRTH], [CYFUHU], Age [AGEIWDATE] [(Respondent)]

During which months of [PYEAR] did [you / he / she] get this income?

- ENTER all that apply
- PROBE: Any others?

| | | | | | | |
|------------|-------------|--------------|-------------|--------------|--------------|---------|
| 1. January | 2. February | 3. March | 4. April | 5. May | 6. June | |
| 7. July | 8. August | 9. September | 10. October | 11. November | 12. December | 13. All |

Workers Compensation

G44B. [CYNAMF CYNAML]: [CYAQRTH], [CYFUHU], Age [AGEIWDATE] [(Respondent)]

(Did [you / [HEAD / SP]] receive any income in [PYEAR]...)

From workers compensation?

1. Yes 5. No → GO TO G44C



G45B. [CYNAMF CYNAML]: [CYAQRTH], [CYFUHU], Age [AGEIWDATE] [(Respondent)]

How much was it?

- ENTER amount here, then SELECT unit of time on next screen (Month, Year)

\$ 1 – 999,997 DK/RF → GO TO G46B



G45BPER. The amount entered is: [G45B] per __

- SELECT the unit of time below

5. Month 6. Year 7. Other-specify (G45BPERSPEC. Specify. (String 100))

G46B. [CYNAMF CYNAML]: [CYAQRTH], [CYFUHU], Age [AGEIWDATE] [(Respondent)]

During which months of [PYEAR] did [you / he / she] get this income?

- ENTER all that apply
- PROBE: Any others?

| | | | | | | |
|------------|-------------|--------------|-------------|--------------|--------------|---------|
| 1. January | 2. February | 3. March | 4. April | 5. May | 6. June | |
| 7. July | 8. August | 9. September | 10. October | 11. November | 12. December | 13. All |

Child Support

G44C. [CYNAMF CYNAML]: [CYAQRTH], [CYFUHU], Age [AGEIWDATE] [(Respondent)]

(Did [you / [HEAD / SP]] receive any income in [PYEAR]...)

From child support?

1. Yes 5. No → GO TO G44D



G45C. [CYNAMF CYNAML]: [CYAQRTH], [CYFUHU], Age [AGEIWDATE] [(Respondent)]

How much was it?

- ENTER amount here, then SELECT unit of time on next screen (Week, Two weeks, Month, Year)

\$ 1 – 999,997 DK/RF → GO TO G46C



G45CPER. The amount entered is: [G45C] per __

- SELECT the unit of time below

| | | | |
|---|--------------|----------|---------|
| 3. Week | 4. Two weeks | 5. Month | 6. Year |
| 7. Other-specify (G45CPERSPEC. Specify. (String 100)) | | | |

G46C. [CYNAMF CYNAML]: [CYAQRTH], [CYFUHU], Age [AGEIWDATE] [(Respondent)]

During which months of [PYEAR] did [you / he / she] get this income?

- ENTER all that apply
- PROBE: Any others?

| | | | | | | |
|------------|-------------|--------------|-------------|--------------|--------------|---------|
| 1. January | 2. February | 3. March | 4. April | 5. May | 6. June | |
| 7. July | 8. August | 9. September | 10. October | 11. November | 12. December | 13. All |

Alimony or Separate Maintenance

G44D. [CYNAMF CYNAML]: [CYAQRTH], [CYFUHU], Age [AGEIWDATE] [(Respondent)]

(Did [you / [HEAD / SP]] receive any income in [PYEAR]...)

From alimony or separate maintenance?

1. Yes 5. No → GO TO G44E

G45D. [CYNAMF CYNAML]: [CYAQRTH], [CYFUHU], Age [AGEIWDATE] [(Respondent)]

How much was it?

- ENTER amount here, then SELECT unit of time on next screen (Week, Two weeks, Month, Year)

\$ 1 – 999,997 DK/RF → GO TO G46D

G45DPER. The amount entered is: [G45D] per ___

- SELECT the unit of time below

3. Week 4. Two weeks 5. Month 6. Year 7. Other-specify (G45DPERSPEC. Specify. (String 100))

G46D. [CYNAMF CYNAML]: [CYAQRTH], [CYFUHU], Age [AGEIWDATE] [(Respondent)]

During which months of [PYEAR] did [you / he / she] get this income?

- ENTER all that apply
- PROBE: Any others?

| | | | | | | |
|-------------------------------------|--------------------------------------|---------------------------------------|--------------------------------------|---------------------------------------|---------------------------------------|----------------------------------|
| 1. January <input type="checkbox"/> | 2. February <input type="checkbox"/> | 3. March <input type="checkbox"/> | 4. April <input type="checkbox"/> | 5. May <input type="checkbox"/> | 6. June <input type="checkbox"/> | |
| 7. July <input type="checkbox"/> | 8. August <input type="checkbox"/> | 9. September <input type="checkbox"/> | 10. October <input type="checkbox"/> | 11. November <input type="checkbox"/> | 12. December <input type="checkbox"/> | 13. All <input type="checkbox"/> |

Help From Relatives

G44E. [CYNAMF CYNAML]: [CYAQRTH], [CYFUHU], Age [AGEIWDATE] [(Respondent)]

Did [you / [HEAD / SP]] receive any help in [PYEAR] from relatives?

- This must be from non-FU members.

1. Yes 5. No → GO TO G44F

G45E. [CYNAMF CYNAML]: [CYAQRTH], [CYFUHU], Age [AGEIWDATE] [(Respondent)]

How much was it?

- ENTER amount here, then SELECT unit of time on next screen (Week, Two weeks, Month, Year)

\$ 1 – 999,997 DK/RF → GO TO G46E

G45EPPER. The amount entered is: [G45E] per ___

- SELECT the unit of time below

3. Week 4. Two weeks 5. Month 6. Year 7. Other-specify (G45EPPERPEC. Specify. (String 100))

G46E. [CYNAMF CYNAML]: [CYAQRTH], [CYFUHU], Age [AGEIWDATE] [(Respondent)]

During which months of [PYEAR] did [you / he / she] get this income?

- ENTER all that apply
- PROBE: Any others?

| | | | | | | |
|-------------------------------------|--------------------------------------|---------------------------------------|--------------------------------------|---------------------------------------|---------------------------------------|----------------------------------|
| 1. January <input type="checkbox"/> | 2. February <input type="checkbox"/> | 3. March <input type="checkbox"/> | 4. April <input type="checkbox"/> | 5. May <input type="checkbox"/> | 6. June <input type="checkbox"/> | |
| 7. July <input type="checkbox"/> | 8. August <input type="checkbox"/> | 9. September <input type="checkbox"/> | 10. October <input type="checkbox"/> | 11. November <input type="checkbox"/> | 12. December <input type="checkbox"/> | 13. All <input type="checkbox"/> |

Help From Non-Relatives

G44F. [CYNAMF CYNAML]: [CYAQRTH], [CYFUHU], Age [AGEIWDATE] [(Respondent)]

Did [you / [HEAD / SP]] receive any help in [PYEAR] from non-relatives or friends?

- This must be from non-FU members.

1. Yes 5. No → GO TO G44G

G45F. [CYNAMF CYNAML]: [CYAQRTH], [CYFUHU], Age [AGEIWDATE] [(Respondent)]

How much was it?

- ENTER amount here, then SELECT unit of time on next screen (Week, Two weeks, Month, Year)

\$ 1 – 999,997 DK/RF → GO TO G46F

G45FPER. The amount entered is: [G45F] per __

- SELECT the unit of time below

3. Week 4. Two weeks 5. Month 6. Year 7. Other-specify (G45FPERSPEC. Specify. (String 100))

G46F. [CYNAMF CYNAML]: [CYAQRTH], [CYFUHU], Age [AGEIWDATE] [(Respondent)]

During which months of [PYEAR] did [you / he / she] get this income?

- ENTER all that apply
- PROBE: Any others?

| | | | | | | |
|-------------------------------------|--------------------------------------|---------------------------------------|--------------------------------------|---------------------------------------|---------------------------------------|----------------------------------|
| 1. January <input type="checkbox"/> | 2. February <input type="checkbox"/> | 3. March <input type="checkbox"/> | 4. April <input type="checkbox"/> | 5. May <input type="checkbox"/> | 6. June <input type="checkbox"/> | |
| 7. July <input type="checkbox"/> | 8. August <input type="checkbox"/> | 9. September <input type="checkbox"/> | 10. October <input type="checkbox"/> | 11. November <input type="checkbox"/> | 12. December <input type="checkbox"/> | 13. All <input type="checkbox"/> |

Anything Else

G44G. [CYNAMF CYNAML]: [CYAQRTH], [CYFUHU], Age [AGEIWDATE] [(Respondent)]

Did [you / [HEAD / SP]] receive any other income in [PYEAR] from anything else?

1. Yes 5. No → GO TO R1CKPT

G45G1. [CYNAMF CYNAML]: [CYAQRTH], [CYFUHU], Age [AGEIWDATE] [(Respondent)]

What was that from?

- IF R mentions income from a job, probe for these details:
- Occ/Ind: What was [your / his / her] occupation? What sort of work did [you / he / she] do? (DO NOT PROBE)
- Start/End: What month and year did [you / he / she] start that job? End that job?
- Job Title/Commute: What was [your / his / her] official job title? On a typical day, how many minutes was [your / his / her] round trip commute to and from work?
- Work hours: How many weeks did [you / he / she] work at that job in [PYEAR]? On average, how many hours per week did [you / he / she] work in [PYEAR]?

Open End

G45G. [CYNAMF CYNAML]: [CYAQRTH], [CYFUHU], Age [AGEIWDATE] [(Respondent)]

How much was the income from that?

- ENTER amount here, then SELECT unit of time on next screen (Week, Two weeks, Month, Year)

\$ 1 – 999,997 DK/RF → GO TO G46G

G45GPER. The amount entered is: [G45G] per __

- SELECT the unit of time below

3. Week 4. Two weeks 5. Month 6. Year 7. Other-specify (G45GPERSPEC. Specify. (String 100))

G46G. [CYNAMF CYNAML]: [CYAQRTH], [CYFUHU], Age [AGEIWDATE] [(Respondent)]

During which months of [PYEAR] did [you / he / she] get this income?

- ENTER all that apply
- PROBE: Any others?

| | | | | | | |
|------------|-------------|--------------|-------------|--------------|--------------|---------|
| 1. January | 2. February | 3. March | 4. April | 5. May | 6. June | |
| 7. July | 8. August | 9. September | 10. October | 11. November | 12. December | 13. All |

P2Year Work Income

R1CKPT. CAI Checkpoint: Whether Head (Spouse/Partner) Worked in P2YEAR

| | | |
|---|---------------|------------------|
| 1. Worked in P2YEAR (BCWTRP2YEAR=1 for Any Job) | 5. All Others | → GO TO G49 RULE |
|---|---------------|------------------|

↓

R2. [CYNAMF CYNAML]: [CYAQRTH], [CYFUHU], Age [AGEIWDATE] [(Respondent)]

Earlier you reported that [you were / [HEAD / SP] was] working in [P2YEAR]. Thinking now about all the work for money that [you / he / she] did during [P2YEAR], including jobs, businesses, self-employment and part-time work, about how much did [you / he / she] earn altogether in [P2YEAR]? Please include any income from bonuses, overtime, tips or commissions.

- IF necessary: Please give me your best estimate
- ENTER amount here, then SELECT unit of time on next screen (Hour, Week, Two weeks, Month, Year)

| | | |
|---------------------|-------|------------------|
| \$ 1 – 9,999,997.99 | DK/RF | → GO TO G49 RULE |
|---------------------|-------|------------------|

↓

R2PER. The amount entered is: [R2] per __

- SELECT the unit of time below

| | | | | |
|---|---------|--------------|----------|---------|
| 1. Hour | 3. Week | 4. Two weeks | 5. Month | 6. Year |
| 7. Other-specify (R2PERSPEC. Specify. (String 100)) | | | | |

G49 Rule: Whether Spouse/Partner in FU

| | | |
|---|---|-------------------|
| Spouse/Partner (CYAQRTH=201-222, CYFUHU=FU, FUMI) | → Repeat G12-R2PER; Then GO TO G73CKPT | No Spouse/Partner |
|---|---|-------------------|

↓

END G12_G46G

Big OFUM Series

G73CKPT. CAI Checkpoint: Whether FU Members are Eligible 16+ Year Old PYEAR OFUM

1. FUP1YEAR: (AGEIWDATE>15 or CS.AGE16=YES) & AQRTH>222 & FUHU=FU, FUMI
2. FUP1YEAR: (AGEIWDATE>15 or CS.AGE16=YES) & AQRTH>222 & FUHU=MO, DIED, INST
3. FUP1YEAR: (AGEIWDATE>15 or CS.AGE16=YES) & AQRTH<223 & FUHU=MO, DIED, INST

| | | | |
|--|---|--|----------------|
| 16+ Year Old FU Member | | | 5. All Others |
| 1. OFUM was FU last wave or became FUMI before CYEAR | 2. OFUM was FU, FUMI last wave but became MO, DIED, or INST in PYEAR or later | 3. HEAD/SP was FU, FUMI last wave but became MO, DIED, or INST in PYEAR or later | GO TO G90BCKPT |

↓

SECTION_G.G73_G90[1-24] [1-24]=AQS of FU Member

G73. AQS of FU Member

G74 Rule: Whether FU Member is Deceased

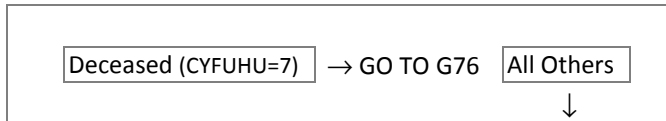

G75. [CYNAMF CYNAML], [CYAQRTH], [AGEIWDATE]

Next we would like to know a little about [CYNAMF CYNAML]. [Are you / Is [he / she]] working now, looking for work, retired, a student, keeping house, or what?

- ENTER all that apply
- PROBE: Any others?

| | | |
|----------------|--|---------------------------------|
| 1. Working now | 2. Only temporarily laid off | 3. Looking for work, unemployed |
| 4. Retired | 5. Disabled, permanently or temporarily | 6. Keeping house |
| 7. Student | 8. Other-specify (G75SPEC. Specify (String 100)) | |

G76. [CYNAMF CYNAML], [CYAQRTH], [AGEIWDATE]

[THIS FU MEMBER DECEASED: Next, we would like to know a little about [CYNAMF CYNAML].]

During [PYEAR], how many full-time or part-time jobs did [you / he / she] have (not counting work around the house)?

| | | | | | |
|-----------------|-------------|---------------|--------------|----------------------|-------|
| 1. Only one job | 2. Two jobs | 3. Three jobs | 4. Four jobs | 5. Didn't have a job | DK/RF |
| ↓ | | | | GO TO G83 | |

SECTION_G.G73_G90[1-24].G77_G81[1-4] [1-24]=AQS of FU Member; [1-4]=Which job

G77. [CYNAMF CYNAML], [CYAQRTH], [AGEIWDATE]

[First / Second / Third / Fourth] Job

[JOBS 2-4: (For the next job...)]

What kind of work did [you / he / she] usually do? What was [your / his / her] occupation?

- [1st JOB AND G76=2-4: R reported multiple jobs -- ask for the main job here]
- DO NOT PROBE

String 500

G77A Rule: Whether First Job Loop (Main Job)

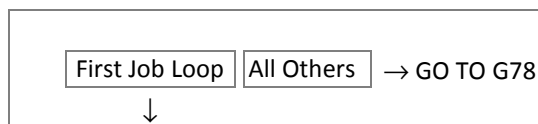

G77A. [CYNAMF CYNAML], [CYAQRTH], [AGEIWDATE]

First Job

What was the official title of [your / his / her] ob? (The title that [your / his / her] employer used.)

- [1st JOB AND G76=2-4: R reported multiple jobs -- ask for the main job here]
- DO NOT PROBE

String 200

G77B. [CYNAMF CYNAML], [CYAQRTH], [AGEIWDATE]

First Job

On a typical day, how many minutes was [your / his / her] round trip commute to and from work?

- [1st JOB AND G76=2-4: R reported multiple jobs -- ask for the main job here]
- If R says "travels from home to temporary lodging near worksite", ENTER [995]
- If R says "it varies", ENTER [996]
- If R says "doesn't commute" (e.g. self-employed, works from home), ENTER [997]

| | | | |
|---------|-------------------------|----------------------|-----------------------|
| 1 – 900 | 995. Temp lodging (VOL) | 996. It varies (VOL) | 997. No commute (VOL) |
|---------|-------------------------|----------------------|-----------------------|

G78. [CYNAMF CYNAML], [CYAQRTH], [AGEIWDAT]E

[First / Second / Third / Fourth] Job

About how much money did [you / he / she] earn from that job last year ([PYEAR])?

- [1st JOB AND G76=2-4: R reported multiple jobs -- ask for the [main job here](#)]
- ENTER amount here, then SELECT unit of time on next screen (Hour, Week, Two weeks, Month, Year)

\$ 1 – 9,999,997.99 DK/RF → GO TO G79

↓

G78PER. The amount entered is: [G78] per __

- SELECT the unit of time below

1. Hour 3. Week 4. Two weeks 5. Month 6. Year

7. Other-specify (G78PERSPEC. Specify. (String 100))

G79. [CYNAMF CYNAML], [CYAQRTH], [AGEIWDAT]E

[First / Second / Third / Fourth] Job

About how many weeks did [you / he / she] work on that job last year ([PYEAR])?

- [1st JOB AND G76=2-4: R reported multiple jobs -- ask for the [main job here](#)]

1 – 52

G80. [CYNAMF CYNAML], [CYAQRTH], [AGEIWDAT]E

[First / Second / Third / Fourth] Job

During which months was that?

- [1st JOB AND G76=2-4: R reported multiple jobs -- ask for the [main job here](#)]
- ENTER all that apply
- PROBE: Any others?

1. January 2. February 3. March 4. April 5. May 6. June
7. July 8. August 9. September 10. October 11. November 12. December 13. All

G81. [CYNAMF CYNAML], [CYAQRTH], [AGEIWDAT]E

[First / Second / Third / Fourth] Job

During the weeks that [you / he / she] worked, about how many hours did [you / he / she] usually work per week?

- [1st JOB AND G76=2-4: R reported multiple jobs -- ask for the [main job here](#)]
- ROUND DOWN for fractions less than ½ (0.5)
- ROUND UP for fractions ½ (0.5) or more

1 – 112

G82 Rule: Whether More Jobs at G76

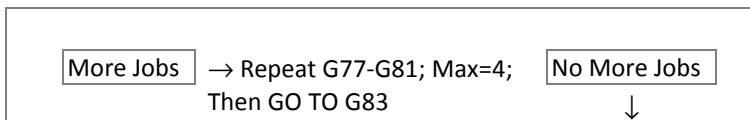

END G77_G81

G83. [CYNAMF CYNAML], [CYAQRTH], [AGEIWDAT]E

Did [you / he / she] have any [other] income, such as pensions, welfare, interest, gifts, or anything else, last year ([PYEAR])?

1. Yes 5. No → GO TO G88CKPT

↓

G84. [CYNAMF CYNAML], [CYAQRTH], [AGEIWDAT]

What was that from?

- ENTER all that apply
- PROBE: Any others?
- SSI (Supplemental Security Income) is **not** Social Security, nor is it Social Security Disability Insurance (SSDI), although the Social Security Administration administers the program and a person can receive both. See F1-Help for more information.

| | | | | |
|------------------------------------|---------------------------------------|------------------------------------|--------------------------------|--|
| 1. Interest G84A-G84AA | 2. TANF/[STATEPROG] G84B-G84BBB | 3. SSI G84C1-G84C5 | 4. Welfare G84D-G84DD | 5. Social Security G84ECKPT, G84E-G84E4 |
| 6. Veterans benefits G84F-G84FF | 7. Pensions, annuities G84G-G84GG | 8. Unemployment comp G84H-G84HH | 9. Worker's comp G84J-G84JJ | |
| 10. Child support G84K-G84KK | 11. Help from relatives G84L-G84LL | 12. Other-specify G84M-G84M3 | | |

G84=Interest

G84A. [CYNAMF CYNAML], [CYAQRTH], [AGEIWDAT]

How much was from interest?

- ENTER amount here, then SELECT unit of time on next screen (Month, Year)

\$ 1 – 999,997 DK/RF → GO TO G84AA



G84APER. The amount entered is: [G84A] per ___

- SELECT the unit of time below

5. Month 6. Year 7. Other-specify (G84APERSPEC. Specify. (String 100))

G84AA. [CYNAMF CYNAML], [CYAQRTH], [AGEIWDAT]

During which months of [PYEAR] did [you / he / she] get this income?

- ENTER all that apply
- PROBE: Any others?

| | | | | | | |
|------------|-------------|--------------|-------------|--------------|--------------|---------|
| 1. January | 2. February | 3. March | 4. April | 5. May | 6. June | |
| 7. July | 8. August | 9. September | 10. October | 11. November | 12. December | 13. All |

G84=TANF

G84B. [CYNAMF CYNAML], [CYAQRTH], [AGEIWDAT]

How much was from TANF (Temporary Assistance for Needy Families) [PYSTATERESIDE<>FC/DK/RF: or [STATEPROG]]?

- ENTER amount here, then SELECT unit of time on next screen (Two weeks, Month, Year)

\$ 1 – 999,997 DK/RF → GO TO G84BB



G84BPER. The amount entered is: [G84B] per ___

- SELECT the unit of time below

4. Two weeks 5. Month 6. Year 7. Other-specify (G84BPERSPEC. Specify. (String 100))

G84BB. [CYNAMF CYNAML], [CYAQRTH], [AGEIWDAT]

During which months of [PYEAR] did [you / he / she] get this income?

- ENTER all that apply
- PROBE: Any others?

| | | | | | | |
|------------|-------------|--------------|-------------|--------------|--------------|---------|
| 1. January | 2. February | 3. March | 4. April | 5. May | 6. June | |
| 7. July | 8. August | 9. September | 10. October | 11. November | 12. December | 13. All |

G84BBB. [CYNAMF CYNAML], [CYAQRTH], [AGEIWDATE]

Who in the family was covered by this?

- ENTER all that apply
- PROBE: Any others?

1 – 24. [CYNAMF CYNAML], [CYAQRTH], [CYFUHU] *AQSN list of FU Members w/FUHU=FU, FUMI≤PYEAR, MO≥PYEAR, DECD≥PYEAR, MILT, EDUC, HLTH, OTHR*

G84=SSI

G84C1. [CYNAMF CYNAML], [CYAQRTH], [AGEIWDATE]

Did [you / he / she] receive the SSI for [yourself / himself / herself], or for someone else?

- SSI (Supplemental Security Income) is **not** Social Security, nor is it Social Security Disability Insurance (SSDI), although the Social Security Administration administers the program and a person can receive both. See F1-Help for more information.

1. Self → GO TO G84C4 2. Someone else 3. Both DK/RF → GO TO G84C4



G84C2. [CYNAMF CYNAML], [CYAQRTH], [AGEIWDATE]

Let's talk about the other person's Supplemental Security when we talk about their income.

- ENTER [1] to continue

1. Continue

G84C3 Rule: Whether SSI for Someone Else or Both

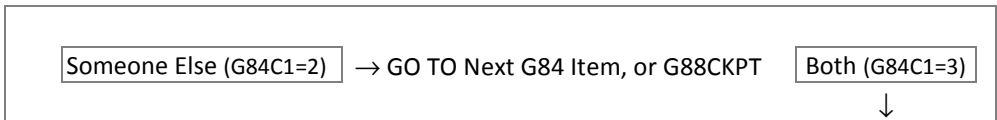

G84C4. [CYNAMF CYNAML], [CYAQRTH], [AGEIWDATE]

How much was [G84C1=SELF: it / ALL OTHERS: the Supplemental Security Income [you / he / she] received for [yourself / himself / herself]]?

- ENTER amount here, then SELECT unit of time on next screen (Month, Year)

\$ 1 – 999,997 DK/RF → GO TO G84C5



G84C4PER. The amount entered is: [G84C4] per ___

- SELECT the unit of time below

5. Month 6. Year 7. Other-specify (G84C4PERSPEC. Specify. (String 100))

G84C5. [CYNAMF CYNAML], [CYAQRTH], [AGEIWDATE]

During which months of [PYEAR] did [you / he / she] get this income?

- ENTER all that apply
- PROBE: Any others?

| | | | | | | |
|------------|-------------|--------------|-------------|--------------|--------------|---------|
| 1. January | 2. February | 3. March | 4. April | 5. May | 6. June | |
| 7. July | 8. August | 9. September | 10. October | 11. November | 12. December | 13. All |

G84=Welfare

G84D. [CYNAMF CYNAML], [CYAQRTH], [AGEIWDATE]

How much was from welfare?

- ENTER amount here, then SELECT unit of time on next screen (Week, Two weeks, Month, Year)

\$ 1 – 999,997 DK/RF → GO TO G84DD



G84DPER. The amount entered is: [G84D] per ___

- SELECT the unit of time below

3. Week 4. Two weeks 5. Month 6. Year 7. Other-specify (G84DPERSPEC. Specify. (String 100))

G84DD. [CYNAMF CYNAML], [CYAQRTH], [AGEIWDATE]

During which months of [PYEAR] did [you / he / she] get this income?

- ENTER all that apply
- PROBE: Any others?

1. January 2. February 3. March 4. April 5. May 6. June
7. July 8. August 9. September 10. October 11. November 12. December 13. All

G84=Social Security

G84ECKPT. CAI Checkpoint: Whether Social Security Already Reported For This OFUM at G32

1. Not Reported 5. Already Reported → GO TO Next G84 Item; or G88CKPT



G84E2A. [CYNAMF CYNAML], [CYAQRTH], [AGEIWDATE]

What was the Social Security? Was that disability, retirement, survivor's benefits or what?

- ENTER all that apply
- PROBE: Any others?

1. Disability 2. Retirement 3. Survivor's benefits 5. Dependent of disabled recipient
6. Dependent of retired recipient 7. Other-specify (G84E2ASPEC. Specify. (String 100))

G84E3. [CYNAMF CYNAML], [CYAQRTH], [AGEIWDATE]

How much was the total amount from Social Security? [*2+ SOCSEC INCOMES*: Please include all amounts from all types of Social Security [you / he / she] received in [PYEAR].]

- ENTER amount here, then SELECT unit of time on next screen (Month, Year)

\$ 1 – 999,997 DK/RF → GO TO G84E4



G84E3PER. The amount entered is: [G84E3] per ___

- SELECT the unit of time below

5. Month 6. Year 7. Other-specify (G84E3PERSPEC. Specify. (String 100))

G84E4. [CYNAMF CYNAML], [CYAQRTH], [AGEIWDATE]

During which months of [PYEAR] did [you / he / she] get this income? [(This includes all types of Social Security [you / he / she] received in [PYEAR].)]

- ENTER all that apply
- PROBE: Any others?

1. January 2. February 3. March 4. April 5. May 6. June
7. July 8. August 9. September 10. October 11. November 12. December 13. All

G84=Veterans benefits

G84F. [CYNAMF CYNAML], [CYAQRTH], [AGEIWDATE]

How much was from veteran's benefits?

- ENTER amount here, then SELECT unit of time on next screen (Month, Year)
- If needed: This includes all types of VA (Veterans Administration) income [you / he / she] received in [PYEAR].

| | | |
|----------------|-------|---------------|
| \$ 1 – 999,997 | DK/RF | → GO TO G84FF |
|----------------|-------|---------------|



G84FPER. The amount entered is: [G84F] per ___

- SELECT the unit of time below

| | | |
|----------|---------|---|
| 5. Month | 6. Year | 7. Other-specify (G84FPERSPEC. Specify. (String 100)) |
|----------|---------|---|

G84FF. [CYNAMF CYNAML], [CYAQRTH], [AGEIWDATE]

During which months of [PYEAR] did [you / he / she] get this income?

- ENTER all that apply
- PROBE: Any others?
- If needed: This includes all types of VA (Veterans Administration) income [you / he / she] received in [PYEAR].

| | | | | | | |
|------------|-------------|--------------|-------------|--------------|--------------|---------|
| 1. January | 2. February | 3. March | 4. April | 5. May | 6. June | |
| 7. July | 8. August | 9. September | 10. October | 11. November | 12. December | 13. All |

G84=Pensions, annuities

G84G. [CYNAMF CYNAML], [CYAQRTH], [AGEIWDATE]

How much was from pensions or annuities?

- ENTER amount here, then SELECT unit of time on next screen (Month, Year)

| | | |
|----------------|-------|---------------|
| \$ 1 – 999,997 | DK/RF | → GO TO G84GG |
|----------------|-------|---------------|



G84GPER. The amount entered is: [G84G] per ___

- SELECT the unit of time below

| | | |
|----------|---------|---|
| 5. Month | 6. Year | 7. Other-specify (G84GPERSPEC. Specify. (String 100)) |
|----------|---------|---|

G84GG. [CYNAMF CYNAML], [CYAQRTH], [AGEIWDATE]

During which months of [PYEAR] did [you / he / she] get this income?

- ENTER all that apply
- PROBE: Any others?

| | | | | | | |
|------------|-------------|--------------|-------------|--------------|--------------|---------|
| 1. January | 2. February | 3. March | 4. April | 5. May | 6. June | |
| 7. July | 8. August | 9. September | 10. October | 11. November | 12. December | 13. All |

G84=Unemployment comp

G84H. [CYNAMF CYNAML], [CYAQRTH], [AGEIWDATE]

How much was from unemployment compensation?

- ENTER amount here, then SELECT unit of time on next screen (Week, Two weeks, Month, Year)

| | | |
|----------------|-------|---------------|
| \$ 1 – 999,997 | DK/RF | → GO TO G84HH |
|----------------|-------|---------------|



G84HPER. The amount entered is: [G84H] per ___

- SELECT the unit of time below

| | | | | |
|---------|--------------|----------|---------|---|
| 3. Week | 4. Two weeks | 5. Month | 6. Year | 7. Other-specify (G84HPERSPEC. Specify. (String 100)) |
|---------|--------------|----------|---------|---|

G84HH. [CYNAMF CYNAML], [CYAQRTH], [AGEIWDATE]

During which months of [PYEAR] did [you / he / she] get this income?

- ENTER all that apply
- PROBE: Any others?

| | | | | | | |
|------------|-------------|--------------|-------------|--------------|--------------|---------|
| 1. January | 2. February | 3. March | 4. April | 5. May | 6. June | |
| 7. July | 8. August | 9. September | 10. October | 11. November | 12. December | 13. All |

G84=Worker's comp

G84J. [CYNAMF CYNAML], [CYAQRTH], [AGEIWDATE]

How much was from worker's compensation?

- ENTER amount here, then SELECT unit of time on next screen (Month, Year)

\$ 1 – 999,997 DK/RF → GO TO G84JJ



G84JPER. The amount entered is: [G84J] per ___

- SELECT the unit of time below

| | | |
|----------|---------|---|
| 5. Month | 6. Year | 7. Other-specify (G84JPERSPEC. Specify. (String 100)) |
|----------|---------|---|

G84JJ. [CYNAMF CYNAML], [CYAQRTH], [AGEIWDATE]

During which months of [PYEAR] did [you / he / she] get this income?

- ENTER all that apply
- PROBE: Any others?

| | | | | | | |
|------------|-------------|--------------|-------------|--------------|--------------|---------|
| 1. January | 2. February | 3. March | 4. April | 5. May | 6. June | |
| 7. July | 8. August | 9. September | 10. October | 11. November | 12. December | 13. All |

G84=Child support

G84K. [CYNAMF CYNAML], [CYAQRTH], [AGEIWDATE]

How much was from child support?

- ENTER amount here, then SELECT unit of time on next screen (Week, Two weeks, Month, Year)

\$ 1 – 999,997 DK/RF → GO TO G84KK



G84KPER. The amount entered is: [G84K] per ___

- SELECT the unit of time below

| | | | |
|---|--------------|----------|---------|
| 3. Week | 4. Two weeks | 5. Month | 6. Year |
| 7. Other-specify (G84KPERSPEC. Specify. (String 100)) | | | |

G84KK. [CYNAMF CYNAML], [CYAQRTH], [AGEIWDATE]

During which months of [PYEAR] did [you / he / she] get this income?

- ENTER all that apply
- PROBE: Any others?

| | | | | | | |
|------------|-------------|--------------|-------------|--------------|--------------|---------|
| 1. January | 2. February | 3. March | 4. April | 5. May | 6. June | |
| 7. July | 8. August | 9. September | 10. October | 11. November | 12. December | 13. All |

G84=Help from relatives

G84L. [CYNAMF CYNAML], [CYAQRTH], [AGEIWDATE]

How much was received from relatives?

- This must be from non-FU members
- ENTER amount here, then SELECT unit of time on next screen (Week, Two weeks, Month, Year)

\$ 1 – 999,997 DK/RF → GO TO G84LL



G84LPER. The amount entered is: [G84L] per __

- SELECT the unit of time below

| | | | |
|---|--------------|----------|---------|
| 3. Week | 4. Two weeks | 5. Month | 6. Year |
| 7. Other-specify (G84LPERSPEC. Specify. (String 100)) | | | |

G84LL. [CYNAMF CYNAML], [CYAQRTH], [AGEIWDATE]

During which months of [PYEAR] did [you / he / she] get this income?

- ENTER all that apply
- PROBE: Any others?

| | | | | | | |
|------------|-------------|--------------|-------------|--------------|--------------|---------|
| 1. January | 2. February | 3. March | 4. April | 5. May | 6. June | |
| 7. July | 8. August | 9. September | 10. October | 11. November | 12. December | 13. All |

G84=Other

G84M. [CYNAMF CYNAML], [CYAQRTH], [AGEIWDATE]

What was that other income from?

- IF R mentions income from a job, PROBE for these details:
- Occ/Ind: What was [your / his / her] occupation? What sort of work did [you / he / she] do? (DO NOT PROBE)
- Start/End: What month and year did [you / he / she] start that job? End that job?
- Job Title/Commute: What was [your / his / her] official job title? On a typical day, how many minutes was [your / his / her] round trip commute to and from work?
- Work Hours: How many weeks did [you / he / she] work at that job in [PYEAR]? On average, how many hours per week did [you / he / she] work in [PYEAR]?

Open End

G84MM. [CYNAMF CYNAML], [CYAQRTH], [AGEIWDATE]

How much was that from that (other income)?

- ENTER amount here, then SELECT unit of time on next screen (Week, Two weeks, Month, Year)

\$ 1 – 999,997 DK/RF → GO TO G84M3



G84MMPER. The amount entered is: [G84MM] per __

- SELECT the unit of time below

| | | | |
|--|--------------|----------|---------|
| 3. Week | 4. Two weeks | 5. Month | 6. Year |
| 7. Other-specify (G84MMPERSPEC. Specify. (String 100)) | | | |

G84M3. [CYNAMF CYNAML], [CYAQRTH], [AGEIWDATE]

During which months of [PYEAR] did [you / he / she] get this income?

- ENTER all that apply
- PROBE: Any others?

| | | | | | | |
|------------|-------------|--------------|-------------|--------------|--------------|---------|
| 1. January | 2. February | 3. March | 4. April | 5. May | 6. June | |
| 7. July | 8. August | 9. September | 10. October | 11. November | 12. December | 13. All |

Big OFUM Education

G88CKPT. CAI Checkpoint: Whether FU Member is Same as Last Wave & Has an OFUM-G Record From Last Wave

1. CYFUHU=FU, INST & PYPERSINFO.OFUMGREC=YES & AGEIWDATE<50, DK/RF
2. CYFUHU=DIED
3. CYFUHU=FU, INST & AGEIWDATE=50-120
4. CYFUHU=FUMI & AGEIWDATE=50-120
5. CYFUHU=FUMI & AGEIWDATE<50, DK/RF
6. CYFUHU=FU, INST & PYPERSINFO.OFUMGREC<>YES & AGEIWDATE<50, DK/RF

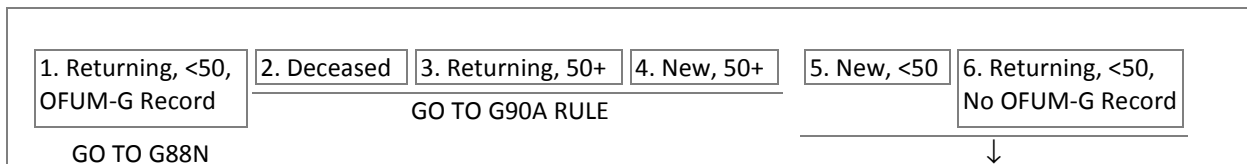

SECTION_G.G73_G90[1-24].G88AG88M3 [1-24]=AQSN of FU Member

G88A. [CYNAMF CYNAML], [CYAQRTH], [AGEIWDATE]

Where did [you / [CYNAMF CYNAML]] receive [your / her / his] education — in the United States, outside the United States, or both?

| | | | | | |
|-----------------------|----------------------|-----------------------------|----|---------------------|----|
| 1. United States only | 2. Outside U.S. only | 3. Both in U.S. and outside | DK | 5. Had no education | RF |
| ↓ | GO TO G88LCKPT | | ↓ | GO TO G88LCKPT | |

G88B1. [CYNAMF CYNAML], [CYAQRTH], [AGEIWDATE]

Now I would like to talk about the education [you have / [she / he] has] received. Did [you / he / she] graduate from high school, get a GED, or neither?

- ENTER [3] if R says OFUM is still in school (attending grade 1-12) or working on a GED

| | | | |
|-------------------------------|--------------|-------------|-------------|
| 1. Graduated from high school | 2. Got a GED | 3. Neither | DK/RF |
| ↓ | GO TO G88C1 | GO TO G88E1 | GO TO G88F1 |

G88B2MO. [CYNAMF CYNAML], [CYAQRTH], [AGEIWDATE]

In what month and year did [you / she / he] graduate?

- SELECT Month and [Enter] to go to next screen for year
- IF NECESSARY: What would be your best estimate?

| | | | | | |
|------------|-------------|--------------|-------------|--------------|--------------|
| 1. January | 2. February | 3. March | 4. April | 5. May | 6. June |
| 7. July | 8. August | 9. September | 10. October | 11. November | 12. December |
| 21. Winter | 22. Spring | 23. Summer | 24. Fall | | |

G88B2YR. [CYNAMF CYNAML], [CYAQRTH], [AGEIWDATE]

(In what month and year did [you / she / he] graduate?)

- The month entered is: [G88BMO]
- ENTER the year below

1920 – [CYEAR]

GO TO G88F1

G88C1. [CYNAMF CYNAML], [CYAQRTH], [AGEIWDATE]

How many grades of regular school did [you / she / he] finish prior to getting [your / her / his] GED?

- Record last grade finished prior to receiving GED
- If needed: Regular school includes high school and schooling that leads to a college or professional school degree.

| | | | |
|---------------|------------------|--------------------|----------------|
| 0. None | 1. First grade | 2. Second grade | 3. Third grade |
| GO TO G88D1MO | 4. Fourth grade | 5. Fifth grade | 6. Sixth grade |
| | 7. Seventh grade | 8. Eighth grade | 9. Ninth grade |
| | 10. Tenth grade | 11. Eleventh grade | DK/RF |

↓

GO TO G88D1MO

G88C2MO. [CYNAMF CYNAML], [CYAQRTH], [AGEIWDATE]

In what month and year did [you / she / he] last attend [G88C1]?

- SELECT Month and [Enter] to go to next screen for year
- IF NECESSARY: What would be your best estimate?

| | | | | | |
|------------|-------------|--------------|-------------|--------------|--------------|
| 1. January | 2. February | 3. March | 4. April | 5. May | 6. June |
| 7. July | 8. August | 9. September | 10. October | 11. November | 12. December |
| 21. Winter | 22. Spring | 23. Summer | 24. Fall | | |

G88C2YR. [CYNAMF CYNAML], [CYAQRTH], [AGEIWDATE]

(In what month and year did [you / she / he] last attend [G88C1]?)

The month entered is: [G88C2MO]

- ENTER the year below

| |
|----------------|
| 1920 – [CYEAR] |
|----------------|

G88D1MO. [CYNAMF CYNAML], [CYAQRTH], [AGEIWDATE]

In what month and year did [you / she / he] receive [your / her / his] GED?

- SELECT Month and [Enter] to go to next screen for year
- IF NECESSARY: What would be your best estimate?

| | | | | | |
|------------|-------------|--------------|-------------|--------------|--------------|
| 1. January | 2. February | 3. March | 4. April | 5. May | 6. June |
| 7. July | 8. August | 9. September | 10. October | 11. November | 12. December |
| 21. Winter | 22. Spring | 23. Summer | 24. Fall | | |

G88D1YR. [CYNAMF CYNAML], [CYAQRTH], [AGEIWDATE]

(In what month and year did [you / she / he] receive [your / her / his] GED?)

The month entered is: [G88D1MO]

- ENTER the year below

| |
|----------------|
| 1920 – [CYEAR] |
|----------------|

GO TO G88F1

G88E1. [CYNAMF CYNAML], [CYAQRTH], [AGEIWDATE]

How many grades of regular school did [you / she / he] finish?

- Record last grade finished
- If needed: Regular school includes high school and schooling that leads to a college or professional school degree.

| | | | |
|-------------|------------------|--------------------|----------------|
| 0. None | 1. First grade | 2. Second grade | 3. Third grade |
| GO TO G88F1 | 4. Fourth grade | 5. Fifth grade | 6. Sixth grade |
| | 7. Seventh grade | 8. Eighth grade | 9. Ninth grade |
| | 10. Tenth grade | 11. Eleventh grade | DK/RF |

↓

GO TO G88F1

G88E2MO. [CYNAMF CYNAML], [CYAQRTH], [AGEIWDAT]E

In what month and what year did [you / she / he] last attend [G88E1]?

- SELECT Month and [Enter] to go to next screen for year
- IF NECESSARY: What would be your best estimate?

| | | | | | |
|------------|-------------|--------------|-------------|--------------|--------------|
| 1. January | 2. February | 3. March | 4. April | 5. May | 6. June |
| 7. July | 8. August | 9. September | 10. October | 11. November | 12. December |
| 21. Winter | 22. Spring | 23. Summer | 24. Fall | | |

G88E2YR. [CYNAMF CYNAML], [CYAQRTH], [AGEIWDAT]E

(In what month and what year did [you / she / he] last attend [G88E1]?)

The month entered is: [G88E2MO]

- ENTER the year below

| |
|----------------|
| 1920 – [CYEAR] |
|----------------|

G88F1. [CYNAMF CYNAML], [CYAQRTH], [AGEIWDAT]E

Did [you / she / he] attend college?

| | | |
|--------|-------|------------------|
| 1. Yes | 5. No | → GO TO G88LCKPT |
|--------|-------|------------------|

↓

G88F2MO. [CYNAMF CYNAML], [CYAQRTH], [AGEIWDAT]E

In what month and year did [you / she / he] last attend college?

- If still in school, ENTER [96] for month
- SELECT Month and [Enter] to go to next screen for year
- NECESSARY: What would be your best estimate?

| | | | | | | |
|------------|-------------|--------------|-------------|--------------|--------------|---------------------|
| 1. January | 2. February | 3. March | 4. April | 5. May | 6. June | |
| 7. July | 8. August | 9. September | 10. October | 11. November | 12. December | 96. Still in school |
| 21. Winter | 22. Spring | 23. Summer | 24. Fall | DK/RF | | |

↓

GO TO G88G

G882FYR. [CYNAMF CYNAML], [CYAQRTH], [AGEIWDAT]E

(In what month and year did [you / she / he] last attend college?)

The month entered is: [G88F2MO]

- ENTER the year below

9996 If still in school

| | |
|----------------|-----------------------|
| 1920 – [CYEAR] | 9996. Still in school |
|----------------|-----------------------|

G88G. [CYNAMF CYNAML], [CYAQRTH], [AGEIWDAT]E

What is the highest year of college [you have / [he / she] has] completed?

- IF R gives a degree: How many years of college [have you / has [she / he]] completed? We'll talk about any college degrees [you have / [he / she] has] earned next.

| | | | |
|-----------------------|---------------|-----------------------|----------------|
| 0. Less than one year | 1. One year | 2. Two years | 3. Three years |
| GO TO G88LCKPT | 4. Four years | 5. Five years or more | DK/RF |

↓

G88H1. [CYNAMF CYNAML], [CYAQRTH], [AGEIWDAT]E

Did [you / she / he] receive a college degree?

| | | |
|--------|-------|------------------|
| 1. Yes | 5. No | → GO TO G88LCKPT |
|--------|-------|------------------|

↓

G88H2. [CYNAMF CYNAML], [CYAQRTH], [AGEIWDAT]

What is the highest college degree [you have / [he / she] has] received?

- PROBE for the **highest** degree received

| | | |
|----------------------------|---------------------------------------|---|
| 1. Associate's degree/AA | 3. Master's degree/MA/MS/MBA | |
| 2. Bachelor's degree/BA/BS | 4. Doctorate/PhD | 5. LLB, JD (Law degrees) |
| | 6. MD, DDS, DVM, DO (Medical degrees) | |
| | 8. Honorary degree | 97. Other-specify (G88H2SPEC. Specify (String 100)) |
| DK/RF | | |

GO TO G88J



G88H3. [CYNAMF CYNAML], [CYAQRTH], [AGEIWDAT]

What was [your / her / his] major at the college or university from which [you / he / she] received [your / his / her] bachelor's degree?

- Probe for details and dual majors

String 100

G88H4. [CYNAMF CYNAML], [CYAQRTH], [AGEIWDAT]

What was the name of the college or university?

- If needed: What was the name of the college or university from which [you / she / he] received [your / her / his] bachelor's degree?

String 100

G88H5CITY. [CYNAMF CYNAML], [CYAQRTH], [AGEIWDAT]

Where was it located?

- If needed: In what city and state was the college or university from which [you / she / he] received [your / her / his] bachelor's degree?

String 100

G88H5STATE. [CYNAMF CYNAML], [CYAQRTH], [AGEIWDAT]

(Where was it located?)

- If needed: In what state was the college or university from which [you / she / he] received [your / her / his] bachelor's degree?
- Start typing the name of the State to bring up the look-up list
- IF foreign country, ENTER [FOR] to select "Foreign Country"

| | | | | |
|-----------------------|---------|-----------------|-------|---------|
| String 30; U.S. State | → GO TO | Foreign Country | DK/RF | → GO TO |
| | G88H6MO | | | G88H6MO |
| | | ↓ | | |

G88H5COUNTRY. [CYNAMF CYNAML], [CYAQRTH], [AGEIWDAT]

(Where was it located?)

- If needed: In what country was the college or university from which [you / she / he] received [your / her / his] bachelor's degree?
- Start typing the name of the Foreign Country to bring up the look-up list

String 30; Country

G88H6MO. [CYNAMF CYNAML], [CYAQRTH], [AGEIWDAT]E]

In what month and year did [you / he / she] receive [your / his / her] bachelor's degree?

- **SELECT Month and [Enter] to go to next screen for year**
- **IF NECESSARY:** What would be your best estimate?

| | | | |
|--------------|-------------|--------------|--------------|
| 1. January | 2. February | 3. March | 4. April |
| 5. May | 6. June | 7. July | 8. August |
| 9. September | 10. October | 11. November | 12. December |
| 21. Winter | 22. Spring | 23. Summer | 24. Fall |

G88H6YR. [CYNAMF CYNAML], [CYAQRTH], [AGEIWDAT]E]

(In what month and year did [you / he / she] receive [your / his / her] bachelor's degree?

The month entered is: [G88H6MO]

- **ENTER the year below**

1920 – [CYEAR]

G88J. [CYNAMF CYNAML], [CYAQRTH], [AGEIWDAT]E] [G88H2]

(And) What was [your / her / his] [*G88H2=BACHELORS*: major / *ALL OTHERS*: area of study] at the college or university from which [you / he / she] received [your / his / her] highest degree?

- **Probe for details and dual majors**

String 100

G88K1. [CYNAMF CYNAML], [CYAQRTH], [AGEIWDAT]E] [G88H2]

What was the name of the college or university?

- **If needed:** What was the name of the college or university from which [you / she / he] received [your / her / his] highest degree?

String 100

G88K2CITY. [CYNAMF CYNAML], [CYAQRTH], [AGEIWDAT]E] [G88H2]

Where was it located?

- **If needed:** In what city and state was the college or university from which [you / she / he] received [your / her / his] highest degree?

String 100

G88K2STATE. [CYNAMF CYNAML], [CYAQRTH], [AGEIWDAT]E] [G88H2]

(Where was it located?)

- **If needed:** In what state was the college or university from which [you / she / he] received [your / her / his] highest degree?
- **Start typing the name of the State to bring up the look-up list**
- **IF foreign country, ENTER [FOR] to select "Foreign Country"**

String 30; U.S. State → GO TO G88K3MO Foreign Country ↓ DK/RF → GO TO G88K3MO

G88K2COUNTRY. [CYNAMF CYNAML], [CYAQRTH], [AGEIWDATE] [G88H2]

(Where was it located?)

- If needed: In what country was the college or university from which [you / she / he] received [your / her / his] highest degree?
- Start typing the name of the Foreign Country to bring up the look-up list

String 30; Country

G88K3MO. [CYNAMF CYNAML], [CYAQRTH], [AGEIWDATE] [G88H2]

In what month and year did [you / he / she] receive [your / his / her] highest degree?

- SELECT Month and [Enter] to go to next screen for year
- IF NECESSARY: What would be your best estimate?

| | | | | | |
|------------|-------------|--------------|-------------|--------------|--------------|
| 1. January | 2. February | 3. March | 4. April | 5. May | 6. June |
| 7. July | 8. August | 9. September | 10. October | 11. November | 12. December |
| 21. Winter | 22. Spring | 23. Summer | 24. Fall | | |

G88K3YR. [CYNAMF CYNAML], [CYAQRTH], [AGEIWDATE] [G88H2]

(In what month and year did [you / he / she] receive [your / his / her] highest degree?)

The month entered is: [G88K3MO]

- ENTER the year below

1920 – [CYEAR]

G88LCKPT. CAI Checkpoint: Where OFUM Educated

| | | |
|-----------------------------|---------------------------|----------------------------|
| 1. Outside U.S. (G88A=2, 3) | 3. U.S. Only (G88A=1, DK) | 5. All Others (G88A=5, RF) |
| ↓ | GO TO G88M2CKPT | GO TO G90A RULE |

G88L. [CYNAMF CYNAML], [CYAQRTH], [AGEIWDATE]

How many years of school did [you / she / he] complete outside of the U.S.?

1 – 25

G88M1. [CYNAMF CYNAML], [CYAQRTH], [AGEIWDATE]

What was the highest degree or certificate [you / she / he] earned outside the U.S.?

String 100

G88M2CKPT. CAI Checkpoint: Whether OFUM Still in School

| | | |
|---|---------------|---------------|
| 1. Still In School (G88F2MO=96 or G88F2YR=9996) | → GO TO G88M3 | 5. All Others |
| | | ↓ |

G88M2. [CYNAMF CYNAML], [CYAQRTH], [AGEIWDATE]

[Are you / Is [he / she]] attending or enrolled in regular school? Regular school includes high school and schooling that leads to a college or professional school degree.

1. Yes 5. No → GO TO G90A RULE

↓

G88M3. [CYNAMF CYNAML], [CYAQRTH], [AGEIWDATE]

[G88M2CKPT=STILL IN SCHOOL: Earlier you said [you are / CYNAMF is] still in school.]
What grade or year [are you / is [he / she]] attending?

| | | | | |
|-----------------------------------|---------------------------------------|-----------------|-----------------|-----------------|
| 1. First grade | 2. Second grade | 3. Third grade | 4. Fourth grade | 5. Fifth grade |
| 6. Sixth grade | 7. Seventh grade | 8. Eighth grade | 9. Ninth grade | 10. Tenth grade |
| 11. Eleventh grade | 12. Twelfth grade, "High School", GED | | | |
| 13. 1st year college (freshman) | 14. 2nd year college (sophomore) | | | |
| 15. 3rd year college (junior) | 16. 4th year college (senior) | | | |
| 17. 5th year or higher of college | 18. Post-graduate work | | | |

GO TO G90A RULE

END G88AG88M3

SECTION_G.G73_G90[1-24].G88NG88DD [1-24]=AQS of FU Member

G88N. [CYNAMF CYNAML], [CYAQRTH], [AGEIWDATE]

Now I would like to talk about the education [you have / [CYNAMF CYNAML] has] received.

[Have you / Has [CYNAMF CYNAML]] attended regular school since our last interview on [PYIWDATE]? Regular school includes high school and schooling that leads to a college or professional school degree.

- ENTER [2] for "still in school"

1. Yes 2. Still in school (IF VOL) 5. No → GO TO G88CCCKPT

↓

G88O. [CYNAMF CYNAML], [CYAQRTH], [AGEIWDATE]

Where did [you / [CYNAMF CYNAML]] receive [your / her / his] education — in the United States, outside the United States, or both?

- If needed: Between our last interview on [PYIWDATE] and now

1. United States only 2. Outside U.S. only 3. Both in U.S. and outside DK RF → GO TO G88AACKPT

↓

GO TO G88AACKPT

↓

G88P1CKPT. CAI Checkpoint: Whether Preloaded Education Level is Less Than HS Grad/GED or Non-Response

1. <HS Grad/GED (PYPERSINFO.COMPEDUC=0-11, NA) 5. All Others → GO TO G88T1

↓

G88P1. [CYNAMF CYNAML], [CYAQRTH], [AGEIWDATE]

(Since our last interview on [PYIWDATE],) did [you / he / she] graduate from high school, get a GED, or neither?

- ENTER [3] if R says OFUM is still in school (attending grade 1-12) or working on a GED

1. Graduated from high school 2. Got a GED 3. Neither DK/RF

↓

GO TO G88Q1

GO TO G88S1

GO TO G88T1

G88P2MO. [CYNAMF CYNAML], [CYAQRTH], [AGEIWDATE]

In what month and year did [you / he / she] graduate?

- If needed: Between our last interview on [PYIWDATE] and now
- SELECT Month and [Enter] to go to next screen for year
- IF NECESSARY: What would be your best estimate?

| | | | | | |
|------------|-------------|--------------|-------------|--------------|--------------|
| 1. January | 2. February | 3. March | 4. April | 5. May | 6. June |
| 7. July | 8. August | 9. September | 10. October | 11. November | 12. December |
| 21. Winter | 22. Spring | 23. Summer | 24. Fall | | |

G88P2YR. [CYNAMF CYNAML], [CYAQRTH], [AGEIWDATE]

(In what year did [you / she / he] graduate?)

- If needed: Between our last interview on [PYIWDATE] and now
- The month entered is: [G88P2MO]
- ENTER the year below

[P2YEAR] – [CYEAR]

GO TO G88T1

HARD CHECK FOR G88P2YR < P2YEAR

IWER: All years prior to [P2YEAR] are not allowed since we are asking about education since [PYIWDATE]. Please VERIFY Year graduated High School since [PYIWDATE]:

- If R confirms the year is before [P2YEAR], then SELECT GoTo to go back to G88N and ENTER [5]
- If R gives a year from [P2YEAR] to [CYEAR], then SELECT Close and ENTER [Year]

G88Q1. [CYNAMF CYNAML], [CYAQRTH], [AGEIWDATE]

How many grades of regular school did [you / he / she] finish prior to getting [your / her / his] GED?

- Record last grade finished prior to receiving GED
- If needed: Regular school includes high school and schooling that leads to a college or professional school degree.

| | | | |
|---------------|------------------|--------------------|----------------|
| 0. None | 1. First grade | 2. Second grade | 3. Third grade |
| GO TO G88R1MO | 4. Fourth grade | 5. Fifth grade | 6. Sixth grade |
| | 7. Seventh grade | 8. Eighth grade | 9. Ninth grade |
| | 10. Tenth grade | 11. Eleventh grade | DK/RF |

↓

GO TO G88R1MO

G88Q2MO. [CYNAMF CYNAML], [CYAQRTH], [AGEIWDATE]

In what month and year did [you / she / he] last attend [G88Q]?

- SELECT Month and [Enter] to go to next screen for year
- IF NECESSARY: What would be your best estimate?

| | | | | | |
|------------|-------------|--------------|-------------|--------------|--------------|
| 1. January | 2. February | 3. March | 4. April | 5. May | 6. June |
| 7. July | 8. August | 9. September | 10. October | 11. November | 12. December |
| 21. Winter | 22. Spring | 23. Summer | 24. Fall | | |

G88QY2R. [CYNAMF CYNAML], [CYAQRTH], [AGEIWDATE]

(In what month and year did [you / she / he] last attend [G88Q]?)

The month entered is: [G88Q2MO]

- ENTER the year below

1920 – [CYEAR]

G88R1MO. [CYNAMF CYNAML], [CYAQRTH], [AGEIWDATE]

In what month and year did [you / she / he] receive [your / her / his] GED?

- If needed: Between our last interview on [PYIWDATE] and now
- SELECT Month and [Enter] to go to next screen for year
- IF NECESSARY: What would be your best estimate?

| | | | | | |
|------------|-------------|--------------|-------------|--------------|--------------|
| 1. January | 2. February | 3. March | 4. April | 5. May | 6. June |
| 7. July | 8. August | 9. September | 10. October | 11. November | 12. December |
| 21. Winter | 22. Spring | 23. Summer | 24. Fall | | |

G88R1YR. [CYNAMF CYNAML], [CYAQRTH], [AGEIWDATE]

(In what month and year did [you / she / he] receive [your / her / his] GED?)

- **If needed:** Between our last interview on [PYIWDATE] and now

The month entered is: [G88R1MO]

- **ENTER** the year below

[P2YEAR] – [CYEAR]

GO TO G88T1

HARD CHECK FOR G88R1YR < P2YEAR

IWER: All years prior to [P2YEAR] are not allowed since we are asking about education since [PYIWDATE]. Please VERIFY Year received GED since [PYIWDATE]:

- If R confirms the year is before [P2YEAR], then **SELECT GoTo** to go back to G88N and **ENTER [5]**
- If R gives a year from [P2YEAR] to [CYEAR], then **SELECT Close** and **ENTER [Year]**

G88S1. [CYNAMF CYNAML], [CYAQRTH], [AGEIWDATE]

How many grades of regular school did [you / she / he] finish?

- **Record last grade finished**
- **If needed:** Regular school includes high school and schooling that leads to a college or professional school degree.

| | | | |
|-------------|------------------|--------------------|----------------|
| 0. None | 1. First grade | 2. Second grade | 3. Third grade |
| GO TO G88T1 | 4. Fourth grade | 5. Fifth grade | 6. Sixth grade |
| | 7. Seventh grade | 8. Eighth grade | 9. Ninth grade |
| | 10. Tenth grade | 11. Eleventh grade | DK/RF |
| | ↓ | | GO TO G88T1 |

G88S2MO. [CYNAMF CYNAML], [CYAQRTH], [AGEIWDATE]

In what month and what year did [you / she / he] last attend [G88S]?

- **SELECT Month** and **[Enter]** to go to next screen for year
- **IF NECESSARY:** What would be your best estimate?

| | | | | | |
|------------|-------------|--------------|-------------|--------------|--------------|
| 1. January | 2. February | 3. March | 4. April | 5. May | 6. June |
| 7. July | 8. August | 9. September | 10. October | 11. November | 12. December |
| 21. Winter | 22. Spring | 23. Summer | 24. Fall | | |

G88S2YR. [CYNAMF CYNAML], [CYAQRTH], [AGEIWDATE]

(In what month and what year did [you / she / he] last attend [G88S]?)

The month entered is: [G882SMO]

- **ENTER** the year below

1920 – [CYEAR]

G88T1. [CYNAMF CYNAML], [CYAQRTH], [AGEIWDATE]

Did [you / she / he] attend college between [PYIWDATE] and now?

1. Yes 5. No → GO TO G88VCKPT

HARD CHECK FOR G88T1=NO, DK/RF and PYPERSINFO.COMPEDUC > 12

IWER: R reported that [CYNAMF CYNAML] attended school since [PYIWDATE], and we know from previous waves that [CYNAMF CYNAML] has already graduated high school or received a GED. Please VERIFY with whether this person attended college since [PYIWDATE]:

- If R says NO or DK/RF, then **SELECT GoTo** to go back to G88N and **ENTER [5]** or [DK, RF]
- If R says YES, then **SELECT Close** and **ENTER [1]**

G88T2MO. [CYNAMF CYNAML], [CYAQRTH], [AGEIWDAT]

In what month and year did [you / she / he] last attend college?

- If needed: Between our last interview on [PYIWDAT] and now
- If still in school, ENTER [96] for month
- SELECT Month and [Enter] to go to next screen for year
- NECESSARY: What would be your best estimate?

| | | | | | |
|--------------|-------------|--------------|--------------|-------|---------------------|
| 1. January | 2. February | 3. March | 4. April | | |
| 5. May | 6. June | 7. July | 8. August | | |
| 9. September | 10. October | 11. November | 12. December | | |
| 21. Winter | 22. Spring | 23. Summer | 24. Fall | DK/RF | 96. Still in school |

↓

GO TO G88VCKPT

G88T2YR. [CYNAMF CYNAML], [CYAQRTH], [AGEIWDAT]

(In what month and year did [you / she / he] last attend college?)

- If needed: Between our last interview on [PYIWDAT] and now
- The month entered is: [G88T2MO]
- ENTER the year below
- 9996 If still in school

| | |
|--------------------|-----------------------|
| [P2YEAR] – [CYEAR] | 9996. Still in school |
|--------------------|-----------------------|

HARD CHECK FOR G88T2YR < P2YEAR

IWER: All years prior to [P2YEAR] are not allowed since we are asking about education since [PYIWDAT]. Please VERIFY Year last attended college since [PYIWDAT]:

- If R confirms the year is before [P2YEAR], then SELECT GoTo to go back to G88N and ENTER [5]
- If R gives a year from [P2YEAR] to [CYEAR], then SELECT Close and ENTER [Year]

G88VCKPT. CAI Checkpoint: Whether OFUM Attended College since Last Wave

| | | |
|------------------------------------|---|---|
| 1. Attended College (G88T1=Yes) | Did Not Attend College (G88T1=No, DK/RF) | |
| ↓ | 3. Preloaded Education=Non-Response (PYPERSINFO.COMPEDUC=NA) | 5. Preloaded Education=Response (PYPERSINFO.COMPEDUC=0-17) |
| | ↓ | GO TO G88AACKPT |

G88V. [CYNAMF CYNAML], [CYAQRTH], [AGEIWDAT]

Altogether, what is the highest year of college [you have / [he / she] has] completed?

- IF R gives a degree: How many years of college [have you / has [she / he]] completed altogether? We'll talk about any college degrees [you have / [he / she] has] earned next.
- [G88VCKPT=3: ENTER [0] if R says None or Never attended college]

| | | | | |
|-----------------------|---------------|-----------------------|----------------|--|
| 0. Less than one year | 1. One year | 2. Two years | 3. Three years | |
| GO TO G88AACKPT | 4. Four years | 5. Five years or more | DK/RF | |

↓

G88WCKPT. CAI Checkpoint: Whether OFUM Attended College since Last Wave

| | |
|---------------------------------|---|
| 1. Attended College (G88T1=Yes) | 5. Did Not Attend College (G88T1=No, DK/RF) |
| ↓ | GO TO G88AACKPT |

G88W. [CYNAMF CYNAML], [CYAQRTH], [AGEIWDAT]E

Did [you / she / he] receive a college degree between [PYIWDAT]E and now?

1. Yes 5. No → GO TO G88AACKPT

↓

G88X1. [CYNAMF CYNAML], [CYAQRTH], [AGEIWDAT]E

(Since our last interview on [PYIWDAT]E,) what college degree did [you / [he / she]] receive?

- If needed: Between our last interview on [PYIWDAT]E and now
- If more than one degree, PROBE for the **highest** degree received since [PYIWDAT]E

| | | |
|----------------------------|---------------------------------------|---|
| 1. Associate's degree/AA | 3. Master's degree/MA/MS/MBA | |
| 2. Bachelor's degree/BA/BS | 4. Doctorate/PhD | 5. LLB, JD (Law degrees) |
| | 6. MD, DDS, DVM, DO (Medical degrees) | |
| | 8. Honorary degree | 97. Other-specify (G88X1SPEC. Specify (String 100)) |
| DK/RF | | |

GO TO G88Y

↓

G88X2. [CYNAMF CYNAML], [CYAQRTH], [AGEIWDAT]E

What was [your / her / his] major at the college or university from which [you / he / she] received [your / his / her] bachelor's degree?

- Probe for details and dual majors

String 100

G88X3. [CYNAMF CYNAML], [CYAQRTH], [AGEIWDAT]E

What was the name of the college or university?

- If needed: What was the name of the college or university from which [you / she / he] received [your / her / his] bachelor's degree?

String 100

G88X4CITY. [CYNAMF CYNAML], [CYAQRTH], [AGEIWDAT]E

Where was it located?

- If needed: In what city and state was the college or university from which [you / she / he] received [your / her / his] bachelor's degree?

String 100

G88X4STATE. [CYNAMF CYNAML], [CYAQRTH], [AGEIWDAT]E

(Where was it located?)

- If needed: In what state is the college or university from which [you / she / he] received [your / her / his] bachelor's degree?
- Start typing the name of the State to bring up the look-up list
- IF foreign country, ENTER [FOR] to select "Foreign Country"

String 30; U.S. State → GO TO G88X5MO Foreign Country DK/RF → GO TO G88X5MO

↓

G88X4COUNTRY. [CYNAMF CYNAML], [CYAQRTH], [AGEIWDAT]E

(Where was it located?)

- If needed: In what country is the college or university from which [you / he / she] received [your / his / her] bachelor's degree?
- Start typing the name of the Foreign Country to bring up the look-up list

String 30; Country

G88X5MO. [CYNAMF CYNAML], [CYAQRTH], [AGEIWDATE]

In what month and year did [you / she / he] receive [your / his / her] bachelor's degree?

- **SELECT** Month and [Enter] to go to next screen for year
- **IF NECESSARY:** What would be your best estimate?

| | | | |
|--------------|-------------|--------------|--------------|
| 1. January | 2. February | 3. March | 4. April |
| 5. May | 6. June | 7. July | 8. August |
| 9. September | 10. October | 11. November | 12. December |
| 21. Winter | 22. Spring | 23. Summer | 24. Fall |

G88X5YR. [CYNAMF CYNAML], [CYAQRTH], [AGEIWDATE]

(In what month and year did [you / she / he] receive [your / his / her] bachelor's degree)?

The month entered is: [G88X_4MO]

- **ENTER** the year below

1920 – [CYEAR]

G88YY. [CYNAMF CYNAML], [CYAQRTH], [AGEIWDATE] [G88X1]

(And) What was [your / her / his] [G88X1=BACHELORS: major / ALL OTHERS: area of study] at the college or university from which [you / he / she] received [your / his / her] highest degree since our last interview on [PYIWDATE]?

- **Probe for details and dual majors**

String 100

G88Z1. [CYNAMF CYNAML], [CYAQRTH], [AGEIWDATE] [G88X1]

What was the name of the college or university?

- **If needed:** What was the name of the college or university from which [you / she / he] received [your / her / his] highest degree (since our last interview on [PYIWDATE])?

String 100

G88Z2CITY. [CYNAMF CYNAML], [CYAQRTH], [AGEIWDATE] [G88X1]

Where was it located?

- **If needed:** In what city and state was the college or university from which [you / she / he] received [your / her / his] highest degree (since our last interview on [PYIWDATE])?

String 100

G88Z2STATE. [CYNAMF CYNAML], [CYAQRTH], [AGEIWDATE] [G88X1]

(Where was it located?)

- **If needed:** In what state is the college or university from which [you / she / he] received [your / her / his] highest degree (since our last interview on [PYIWDATE])?
- **Start typing the name of the State to bring up the look-up list**
- **IF foreign country, ENTER [FOR] to select "Foreign Country"**

String 30; U.S. State → GO TO G88Z3MO Foreign Country DK/RF → GO TO G88Z3MO

↓

G88Z2COUNTRY. [CYNAMF CYNAML], [CYAQRTH], [AGEIWDATE] [G88X1]

(Where was it located?)

- **If needed:** In what country is the college or university from which [you / he / she] received [your / his / her] highest degree (since our last interview on [PYIWDATE])?
- **Start typing the name of the Foreign Country to bring up the look-up list**

String 30; Country

G88Z3MO. [CYNAMF CYNAML], [CYAQRTH], [AGEIWDATE] [G88X1]

In what month and year did [you / she / he] receive [your / her / his] highest degree?

- If needed: Between our last interview on [PYIWDATE] and now
- SELECT Month and [Enter] to go to next screen for year
- IF NECESSARY: What would be your best estimate?

| | | | | | |
|------------|-------------|--------------|-------------|--------------|--------------|
| 1. January | 2. February | 3. March | 4. April | 5. May | 6. June |
| 7. July | 8. August | 9. September | 10. October | 11. November | 12. December |
| 21. Winter | 22. Spring | 23. Summer | 24. Fall | | |

G88Z3YR. [CYNAMF CYNAML], [CYAQRTH], [AGEIWDATE] [G88X1]

(In what month and year did [you / she / he] receive [your / her / his] highest degree)?

- If needed: Between our last interview on [PYIWDATE] and now

The month entered is: [G88Z3MO]

- ENTER the year below

[P2YEAR] – [CYEAR]

HARD CHECK FOR G88Z3YR < P2YEAR

IWER: All years prior to [P2YEAR] are not allowed since we are asking about education since [PYIWDATE]. Please VERIFY Year received highest degree since [PYIWDATE]:

- If R confirms the year is before [P2YEAR], then SELECT GoTo to go back to G88N and ENTER [5]
- If R gives a year from [P2YEAR] to [CYEAR], then SELECT Close and ENTER [Year]

G88AACKPT. CAI Checkpoint: Where OFUM Educated

| | | | |
|-------------------------------|---------------------------|-------------------------|-------------------|
| 1. Outside U.S. (G88O = 2, 3) | 3. U.S. Only (G88O=1, DK) | 5. All Others (G88O=RF) | → GO TO G90A RULE |
| ↓ | GO TO G88CCCKPT | | |

G88AA. [CYNAMF CYNAML], [CYAQRTH], [AGEIWDATE]

Between [PYIWDATE] and now, how many years of school did [you / she / he] complete outside of the U.S.?

1 – 3

G88BB. [CYNAMF CYNAML], [CYAQRTH], [AGEIWDATE]

(Between [PYIWDATE] and now,) what was the highest degree or certificate [you / she / he] earned outside the U.S.?

String 100

G88CCCKPT. CAI Checkpoint: Whether OFUM Still in School

| | | |
|---|---------------|---------------|
| 1. Still In School (G88N=2 or G88T2MO=96 or G88T2YR=9996) | → GO TO G88DD | 5. All Others |
| | | ↓ |

G88CC. [CYNAMF CYNAML], [CYAQRTH], [AGEIWDATE]

[Are you / Is [he / she]] attending or enrolled in regular school? (Regular school includes high school and schooling that leads to a college or professional school degree.)

1. Yes 5. No → GO TO G90A RULE

↓

G88DD. [CYNAMF CYNAML], [CYAQRTH], [AGEIWDATE]

[G88CCCKPT=STILL IN SCHOOL: Earlier you said [you are / CYNAMF is] still in school.]
 What grade or year [are you / is [he / she]] attending?

| | | | | |
|-----------------------------------|---------------------------------------|-----------------|-----------------|-----------------|
| 1. First grade | 2. Second grade | 3. Third grade | 4. Fourth grade | 5. Fifth grade |
| 6. Sixth grade | 7. Seventh grade | 8. Eighth grade | 9. Ninth grade | 10. Tenth grade |
| 11. Eleventh grade | 12. Twelfth grade, "High School", GED | | | |
| 13. 1st year college (freshman) | 14. 2nd year college (sophomore) | | | |
| 15. 3rd year college (junior) | 16. 4th year college (senior) | | | |
| 17. 5th year or higher of college | 18. Post-graduate work | | | |

GO TO G90A RULE

END G88NG88DD

G90A Rule: Whether There are More Big OFUMs

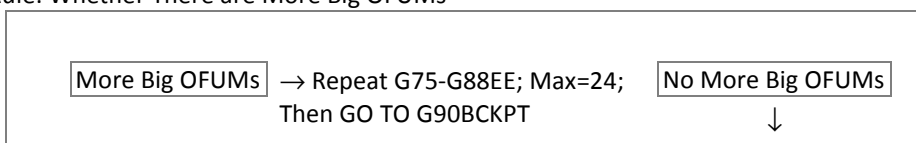

END G73_G90

Little OFUM Series

G90BCKPT. CAI Checkpoint: Whether FU Members are Eligible <16 Year Old PYEAR OFUM

1. FUP1YEAR (AGEIWDATE<16 or CS.AGE16=NO) & AQRTH>222 & FUHU=FU, FUMI
2. FUP1YEAR (AGEIWDATE<16 or CS.AGE16=NO) & AQRTH>222 & FUHU=MO, DIED, INST

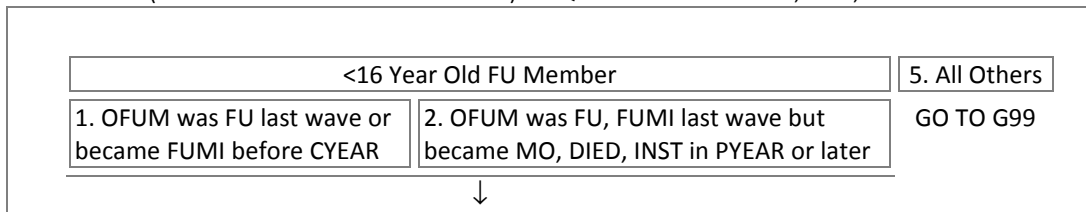

SECTION_G.G90D_G97[1-24] [1-24]=AQSN of FU Member

G90D. [CYNAMF CYNAML], [CYAQRTH], [AGEIWDATE]

[LOOP 1: Now the younger member(s) of your family.]

Did [CYNAMF CYNAML] have any income in [PYEAR]?

1. Yes 5. No → GO TO G98 RULE

↓

G92. [CYNAMF CYNAML], [CYAQRTH], [AGEIWDATE]

Now, we would like to ask about [CYNAMF CYNAML's] income. What was that from?

- ENTER all that apply
- PROBE: Any others?
- SSI (Supplemental Security Income) is **not** Social Security, nor is it Social Security Disability Insurance (SSDI), although the Social Security Administration administers the program and a person can receive both. See F1-Help for more information.

| | | | | | |
|------------------------|-------------|------------|------------|-------------------------|------------------|
| 1. Work | 2. Interest | 3. SSI | 4. Welfare | 5. Social Security | 6. Other-specify |
| G94A-G94AA, G95-G97 | G94B-G94BB | G94C-G94CC | G94D-G94DD | G94ECKPT, G94E-G94E4 | G94F-G94F3 |

G92=Work

G94A. [CYNAMF CYNAML], [CYAQRTH], [AGEIWDATE]

How much was from work?

- ENTER amount here, then SELECT unit of time on next screen (Hour, Week, Two weeks, Month, Year)

| | | |
|-----------------------|-------|---------------|
| \$ 1.0 – 9,999,997.99 | DK/RF | → GO TO G94AA |
|-----------------------|-------|---------------|



G94APER. The amount entered is: [G94A] per ___

- SELECT the unit of time below

| | | | | |
|---|---------|--------------|----------|---------|
| 1. Hour | 3. Week | 4. Two weeks | 5. Month | 6. Year |
| 7. Other-specify (G94APERSPEC. Specify. (String 100)) | | | | |

G94AA. [CYNAMF CYNAML], [CYAQRTH], [AGEIWDATE]

During which months of [PYEAR] did [he / she] get this income?

- ENTER all that apply
- PROBE: Any others?

| | | | | | | |
|------------|-------------|--------------|-------------|--------------|--------------|---------|
| 1. January | 2. February | 3. March | 4. April | 5. May | 6. June | |
| 7. July | 8. August | 9. September | 10. October | 11. November | 12. December | 13. All |

G95. [CYNAMF CYNAML], [CYAQRTH], [AGEIWDATE]

What was [his / her] occupation? What kind of work did [he / she] do?

- DO NOT PROBE

| |
|------------|
| String 500 |
|------------|

G96. [CYNAMF CYNAML], [CYAQRTH], [AGEIWDATE]

About how many weeks did [he / she] work on that job last year ([PYEAR])?

| |
|--------|
| 1 – 52 |
|--------|

G97. [CYNAMF CYNAML], [CYAQRTH], [AGEIWDATE]

During the weeks that [he / she] worked, about how many hours did [he / she] usually work per week?

- ROUND DOWN for fractions less than $\frac{1}{2}$ (0.5)
- ROUND UP for fractions $\frac{1}{2}$ (0.5) or more

| |
|---------|
| 1 – 112 |
|---------|

G92=Interest

G94B. [CYNAMF CYNAML], [CYAQRTH], [AGEIWDATE]

How much was from interest?

- ENTER amount here, then SELECT unit of time on next screen (Month, Year)

| | | |
|----------------|-------|---------------|
| \$ 1 – 999,997 | DK/RF | → GO TO G94BB |
|----------------|-------|---------------|



G94BPER. The amount entered is: [G94B] per ___

- SELECT the unit of time below

| | | |
|----------|---------|---|
| 5. Month | 6. Year | 7. Other-specify (G94BPERSPEC. Specify. (String 100)) |
|----------|---------|---|

G94BB. [CYNAMF CYNAML], [CYAQRTH], [AGEIWDATE]

During which months of [PYEAR] did [he / she] get this income?

- ENTER all that apply
- PROBE: Any others?

| | | | | | | |
|------------|-------------|--------------|-------------|--------------|--------------|---------|
| 1. January | 2. February | 3. March | 4. April | 5. May | 6. June | |
| 7. July | 8. August | 9. September | 10. October | 11. November | 12. December | 13. All |

G92=SSI

G94C. [CYNAMF CYNAML], [CYAQRTH], [AGEIWDATE]

How much was from SSI?

- ENTER amount here, then SELECT unit of time on next screen (Month, Year)
- SSI (Supplemental Security Income) is **not** Social Security, nor is it Social Security Disability Insurance (SSDI), although the Social Security Administration administers the program and a person can receive both. See F1-Help for more information.

| | | |
|----------------|-------|---------------|
| \$ 1 – 999,997 | DK/RF | → GO TO G94CC |
|----------------|-------|---------------|



G94CPER. The amount entered is: [G94C] per __

- SELECT the unit of time below

| | | |
|----------|---------|---|
| 5. Month | 6. Year | 7. Other-specify (G94CPERSPEC. Specify. (String 100)) |
|----------|---------|---|

G94CC. [CYNAMF CYNAML], [CYAQRTH], [AGEIWDATE]

During which months of [PYEAR] did [he / she] get this income?

- ENTER all that apply
- PROBE: Any others?

| | | | | | | |
|------------|-------------|--------------|-------------|--------------|--------------|---------|
| 1. January | 2. February | 3. March | 4. April | 5. May | 6. June | |
| 7. July | 8. August | 9. September | 10. October | 11. November | 12. December | 13. All |

G92=Welfare

G94D. [CYNAMF CYNAML], [CYAQRTH], [AGEIWDATE]

How much was from welfare?

- ENTER amount here, then SELECT unit of time on next screen (Week, Two weeks, Month, Year)

| | | |
|----------------|-------|---------------|
| \$ 1 – 999,997 | DK/RF | → GO TO G94DD |
|----------------|-------|---------------|



G94DPER. The amount entered is: [G94D] per __

- SELECT the unit of time below

| | | | |
|---|--------------|----------|---------|
| 3. Week | 4. Two weeks | 5. Month | 6. Year |
| 7. Other-specify (G94DPERSPEC. Specify. (String 100)) | | | |

G94DD. [CYNAMF CYNAML], [CYAQRTH], [AGEIWDATE]

During which months of [PYEAR] did [he / she] get this income?

- ENTER all that apply
- PROBE: Any others?

| | | | | | | |
|------------|-------------|--------------|-------------|--------------|--------------|---------|
| 1. January | 2. February | 3. March | 4. April | 5. May | 6. June | |
| 7. July | 8. August | 9. September | 10. October | 11. November | 12. December | 13. All |

G92=Social Security

G94ECKPT. CAI Checkpoint: Whether Social Security Already Reported For This OFUM at G32

| | | |
|-----------------|---------------------|------------------------------------|
| 1. Not Reported | 5. Already Reported | → GO TO Next G94 Item; or G98 RULE |
|-----------------|---------------------|------------------------------------|



G94E2A. [CYNAMF CYNAML], [CYAQRTH], [AGEIWDATE]

What was the Social Security? Was that survivor's benefits, dependent assistance, or what?

- ENTER all that apply
- PROBE: Any others?

| | |
|-----------------------------------|--|
| 3. Survivors benefits | 5. Dependent of disabled recipient |
| 6. Dependent of retired recipient | 7. Other-specify (G94E2ASPEC. Specify. (String 100)) |

G94E3. [CYNAMF CYNAML], [CYAQRTH], [AGEIWDATE]

How much was the total amount from Social Security? [2+ SOCSEC INCOMES: Please include all amounts from all types of Social Security [you / he / she] received in [PYEAR].]

- ENTER amount here, then SELECT unit of time on next screen (Month, Year)

\$ 1 – 999,997 DK/RF → GO TO G94E4



G94E3PER. The amount entered is: [G94E3] per ___

- SELECT the unit of time below

| | | |
|----------|---------|--|
| 5. Month | 6. Year | 7. Other-specify (G94E3PERSPEC. Specify. (String 100)) |
|----------|---------|--|

G94E4. [CYNAMF CYNAML], [CYAQRTH], [AGEIWDATE]

During which months of [PYEAR] did [you / he / she] get this income? [(This includes all types of Social Security [you / he / she] received in [PYEAR].)]

- ENTER all that apply
- PROBE: Any others?

| | | | | | | |
|------------|-------------|--------------|-------------|--------------|--------------|---------|
| 1. January | 2. February | 3. March | 4. April | 5. May | 6. June | |
| 7. July | 8. August | 9. September | 10. October | 11. November | 12. December | 13. All |

G92=Other

G94F. [CYNAMF CYNAML], [CYAQRTH], [AGEIWDATE]

What was that other income from?

- DO NOT include gifts, allowances, or other money from other FU members
- IF R mentions income from a job, PROBE for these details:
- Occ/Ind: What was [his / her] occupation? What sort of work did [he / she] do? (DO NOT PROBE)
- Start/End: What month and year did [he / she] start that job? End that job?
- Work Hours: How many weeks did [he / she] work at that job in [PYEAR]? On average, how many hours per week did [he / she] work in [PYEAR]?

Open End

G94F2. [CYNAMF CYNAML], [CYAQRTH], [AGEIWDATE]

How much was it?

- ENTER amount here, then SELECT unit of time on next screen (Week, Two weeks, Month, Year)

\$ 1 – 999,997 DK/RF → GO TO G94F3



G94F2PER. The amount entered is: [G94F2] per ___

- SELECT the unit of time below

| | | | |
|--|--------------|----------|---------|
| 3. Week | 4. Two weeks | 5. Month | 6. Year |
| 7. Other-specify (G94F2PERSPEC. Specify. (String 100)) | | | |

G94F3. [CYNAMF CYNAML], [CYAQRTH], [AGEIWDATE]

During which months of [PYEAR] did [he / she] get this income?

- ENTER all that apply
- PROBE: Any others?

| | | | | | | |
|------------|-------------|--------------|-------------|--------------|--------------|---------|
| 1. January | 2. February | 3. March | 4. April | 5. May | 6. June | |
| 7. July | 8. August | 9. September | 10. October | 11. November | 12. December | 13. All |

G98 Rule: Whether There are More Little OFUMs

| | | |
|-------------------|---|----------------------|
| More Little OFUMs | → Repeat G92-G94F3; Max=24; Then GO TO G99 | No More Little OFUMs |
| | | ↓ |

END G90D_G97

G99. Did [you / [HEAD]] [or anyone else in [your / his / her] family living there] get any other money in [PYEAR] - like a big settlement from an insurance company, or an inheritance?

1. Yes 5. No → GO TO G102

↓

G100. How much did that amount to?

\$ 1 – 9,999,997

G101. How much of that was an inheritance?

\$ 0 – 9,999,997

G102. Some people have expenses they can itemize and deduct on their income tax. Did [*R=HEAD, SP: you / R=OFUM, PROXY: [HEAD] SP IN FU: and [SP]]*] itemize deductions on [*R=HEAD, SP: your / R=OFUM, PROXY: [his / her / SP IN FU: their]*] [PYEAR] federal income tax, such as property taxes, interest payments, medical expenses, and charitable contributions?

1. Yes 5. No or did / will not file → GO TO G103

↓

G102A. How much was [your / his / her] itemized deduction for charitable contributions?

\$ 0 – 999,997

G102B. How much was [your / his / her] itemized deduction for medical expenses?

- IF necessary: Is that the amount of the deduction or is that the total medical expenses? What was the amount of the deduction?

\$ 0 – 999,997

G103. In [PYEAR], did [you / [HEAD]] [or anyone else in [your / his / her] family living there] give any money toward the support of anyone who was not living there at the time, including child support, alimony, money given to parents, and things like that? Don't include loans or charitable contributions to organizations; we'll ask about them later.

1. Yes 5. No → GO TO SECTION W

↓

G104. How many people was that?

1 – 9 DK/RF → GO TO G106

↓

SECTION_G.G105.G105PEOPLE[1-24] [1-24]=Which person
FIRSTNAME. What is the [first / next] person's first and last name?

- ENTER First name

String 10

LASTNAME. (What is the [first / next] person's first and last name?)

- ENTER Last name

String 15

G105RTHLAB. What is [G105FIRSTNAME G105LASTNAME]'s relationship to [you / [HEAD]]?

- ENTER person's relationship to Head

String 50: RTH

END G105PEOPLE

G106 Rule: Whether More People Reported at G104

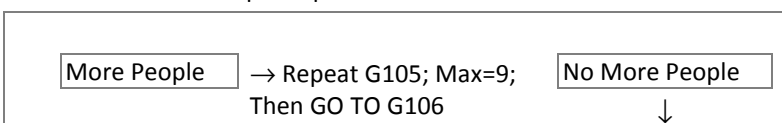

G106. How much money was that altogether in [PYEAR]?

\$ 1 – 9,999,997

G107. Was any of that child support?

→ GO TO G109



G108. How much did that child support amount to in [PYEAR]?

\$ 1 – [G106 / 9,999,997]

G109. Was any of the money [you / [HEAD]] gave in [PYEAR] alimony?

→ GO TO G111 RULE



G110. How much did that alimony amount to in [PYEAR]?

\$ 1 – [G106 / 9,999.997]

G111 Rule: Number of People Reported at G104



G112. Were any of those people dependent on [you / [HEAD]] for more than half of their total support?

→ GO TO SECTION W



G113. How many people was that?

1 – 9

G114. Was that person dependent on [you / [HEAD]] for more than half of their total support?

END SECTION_G

Section W: Wealth and Active Savings

[TOC](#)

SECTION_W

W1. The next questions I will be asking are designed to give estimates of the wealth of families. [*R=HEAD, SP, OFUM*: In these questions when I refer to the family, I mean your family living there with you.]

Do you [or your family living there] have any real estate [*A19=OWNS*: other than your main home,] such as a second home, land (not including farmland), rental real estate, or money owed to you on a land contract?

1. Yes 5. No → GO TO W6



W1A. Does that include a second home?

1. Yes 5. No

W2A. How much is the real estate worth, that is, how much would it sell for?

- **If needed:** Real estate [*A19=OWNS*: other than your main home,] such as a second home, land (not including farmland), rental real estate, or money owed to you on a land contract

\$ 0 - 999,999,997 → GO TO W2B DK/RF



| | | | | | |
|---|--|--------------------------------|------------------------|--|--|
| W3A. Would it amount to \$50,000 or more? | | | | | |
| <input type="checkbox"/> 1. Yes | | <input type="checkbox"/> 5. No | | <input type="checkbox"/> DK/RF → GO TO W2B | |
| ↓ | | ↓ | | | |
| W4A. \$175,000 or more? | | | W5A. \$20,000 or more? | | |
| <input type="checkbox"/> 1. Yes | | <input type="checkbox"/> 5. No | | <input type="checkbox"/> DK/RF | |
| <input type="checkbox"/> 1. Yes | | <input type="checkbox"/> 5. No | | <input type="checkbox"/> DK/RF | |

W2B. (And) how much debt do you owe on that (real estate)?

- **If needed:** Real estate [*A19=OWNS*: other than your main home,] such as a second home, land (not including farmland), rental real estate, or money owed to you on a land contract

\$ 0 - 999,999,997 → GO TO W6 DK/RF



| | | | | | |
|---|--|--------------------------------|------------------------|---|--|
| W3B. Would it amount to \$50,000 or more? | | | | | |
| <input type="checkbox"/> 1. Yes | | <input type="checkbox"/> 5. No | | <input type="checkbox"/> DK/RF → GO TO W6 | |
| ↓ | | ↓ | | | |
| W4B. \$175,000 or more? | | | W5B. \$20,000 or more? | | |
| <input type="checkbox"/> 1. Yes | | <input type="checkbox"/> 5. No | | <input type="checkbox"/> DK/RF | |
| <input type="checkbox"/> 1. Yes | | <input type="checkbox"/> 5. No | | <input type="checkbox"/> DK/RF | |

W6. What about the value of what you [or anyone in your family living there] own on wheels? Including [F47=YES: personal vehicles you may have already told me about and] any cars, trucks, a motor home, a trailer, or a boat - what are they worth all together, minus anything you still owe on them?

- Include only vehicles owned by the FU
- DO NOT include vehicles owned by HU or HUCS people

\$ -99,999,999 – 999,999,997 → GO TO W10 DK/RF

↓

| | | | | | |
|--|-------|----------------------------|----------------------|-------|-------|
| W7. Would they amount to \$10,000 or more? | | | | | |
| 1. Yes | | 5. No DK/RF → GO TO W10 | | | |
| ↓ | | ↓ | | | |
| W8. \$25,000 or more? | | | W9. \$2,000 or more? | | |
| 1. Yes | 5. No | DK/RF | 1. Yes | 5. No | DK/RF |

W10. Do you [or anyone in your family living there] currently own part or all of a farm or business?

1. Yes 5. No → GO TO W15

↓

W11A. How much is your part (of the farm or business) worth, that is, how much would it sell for?

\$ 0 - 999,999,997 → GO TO W11B DK/RF

↓

| | | | | | |
|--|-------|-----------------------------|-------------------------|-------|-------|
| W12A. Would it amount to \$50,000 or more? | | | | | |
| 1. Yes | | 5. No DK/RF → GO TO W11B | | | |
| ↓ | | ↓ | | | |
| W13A. \$200,000 or more? | | | W14A. \$10,000 or more? | | |
| 1. Yes | 5. No | DK/RF | 1. Yes | 5. No | DK/RF |

W11B. And how much debt do you owe on that (farm or business)?

\$ 0 - 999,999,997 → GO TO W15 DK/RF

↓

| | | | | | |
|--|-------|----------------------------|-------------------------|-------|-------|
| W12B. Would it amount to \$50,000 or more? | | | | | |
| 1. Yes | | 5. No DK/RF → GO TO W15 | | | |
| ↓ | | ↓ | | | |
| W13B. \$200,000 or more? | | | W14B. \$10,000 or more? | | |
| 1. Yes | 5. No | DK/RF | 1. Yes | 5. No | DK/RF |

W15. (Do you [or anyone in your family living there] have...)

Any shares of stock in publicly held corporations, stock mutual funds, or investment trusts, not including stocks in employer-based pensions or I.R.A.s (Individual Retirement Account)?

1. Yes 5. No → GO TO W21



W16. If you sold all that and paid off anything you owed on it, how much would you have?

→ GO TO W20CCKPT DK/RF



| | |
|---|---|
| W17. Would it amount to \$50,000 or more? | |
| <input type="checkbox"/> 1. Yes | <input type="checkbox"/> 5. No <input type="checkbox"/> DK/RF → GO TO W21 |
| ↓ | ↓ |
| W20. \$150,000 or more? | W19. \$15,000 or more? |
| <input type="checkbox"/> 1. Yes <input type="checkbox"/> 5. No <input type="checkbox"/> DK/RF | <input type="checkbox"/> 1. Yes <input type="checkbox"/> 5. No <input type="checkbox"/> DK/RF |
| GO TO W21 | GO TO W21 |

W20CCKPT. CAI Checkpoint: Whether Dividends Reported But Dividend Income Was Not (Section G)

| | |
|---|--|
| <input type="checkbox"/> 1. Dividends Reported/Income Not Reported (W16=1-999,999,997 & G25B[1]<>Yes & G25B[2]<>Yes) | <input type="checkbox"/> 5. All Others → GO TO W21 |
| ↓ | |

W20E. [*HEAD + SP IN FU*: For both [*R=HEAD*: you and [*SP*] / *R=SP*: you and [*HEAD*] / *R=OFUM, PROXY*: [*HEAD*] and [*SP*]], how much / *ALL OTHERS*: How much] in dividends did [you / [they / he / she]] receive altogether in [*PYEAR*]?

- Includes reinvested dividends
- ENTER amount here, then SELECT unit of time on next screen (Month, Year)

→ GO TO W21 DK/RF → GO TO W20F



W20EPER. The amount entered is: [W20E] per ____

- SELECT the unit of time below

5. Month 6. Year 7. Other-specify (W20EPERSPEC. Specify. (String 100))

W20F. During which months of [*PYEAR*] did you get this income?

- ENTER all that apply
- PROBE: Any others?

| | | | | | | |
|-------------------------------------|--------------------------------------|---------------------------------------|--------------------------------------|---------------------------------------|---------------------------------------|----------------------------------|
| <input type="checkbox"/> 1. January | <input type="checkbox"/> 2. February | <input type="checkbox"/> 3. March | <input type="checkbox"/> 4. April | <input type="checkbox"/> 5. May | <input type="checkbox"/> 6. June | |
| <input type="checkbox"/> 7. July | <input type="checkbox"/> 8. August | <input type="checkbox"/> 9. September | <input type="checkbox"/> 10. October | <input type="checkbox"/> 11. November | <input type="checkbox"/> 12. December | <input type="checkbox"/> 13. All |

W21. (Do you [or anyone in your family living there] have...)

Any money in private annuities or Individual Retirement Accounts (I.R.A.s)?

1. Yes 5. No → GO TO W27



W21A. Are they mostly in stocks, mostly in interest earning assets, split between the two, or what?

1. Mostly stocks 2. Mostly interest earning 3. Split

W22. How much would they be worth?

\$ 1 – 999,999,997 → GO TO W27

DK/RF



W23. Would it amount to \$50,000 or more?

1. Yes

5. No DK/RF → GO TO W27



W24. \$100,000 or more?

W25. \$15,000 or more?

1. Yes 5. No DK/RF

1. Yes 5. No DK/RF

↓ GO TO W27

↓ GO TO W27

W26. \$250,000 or more?

1. Yes 5. No DK/RF

W27. Not including employer-based pensions or I.R.A.s (Individual Retirement Account), do you [or anyone in your family living there] have any money in any of the following:

Checking or savings accounts,
Money market funds,
Certificates of deposit,
Government bonds, or
Treasury bills?

1. Yes, one or more → GO TO W28 5. No, none DK/RF



W27A. Do you [or anyone in your family living there] have a checking or a savings account?

1. Yes, one or more 5. No, none → GO TO W33



W28. If you added up all such accounts [for all of your family living there], about how much would they amount to altogether right now?

[W27<>YES: \$ 0 / W27=YES: \$ 1] – 999,999,997 → GO TO W31CCKPT DK/RF



W29. Would they amount to \$5,000 or more?

1. Yes

5. No DK/RF → GO TO W33



W30. \$10,000 or more?

W32. \$1,000 or more?

1. Yes 5. No DK/RF

1. Yes 5. No DK/RF

↓ GO TO W33

↓ GO TO W33

W31. \$50,000 or more?

1. Yes 5. No DK/RF

GO TO W33

W31CCKPT. CAI Checkpoint: Whether Interest Reported But Interest Income Was Not (Section G)

| | |
|---|---------------------------|
| 1. Interest Reported/Income Not Reported (W28=1-9,999,997 & G25C[1]<>Yes & G25C[2]<>Yes) | 5. All Others → GO TO W33 |
| ↓ | |

W31E. [HEAD and SP IN FU: For both [R=HEAD: you and [SP] / R=SP: you and [HEAD] / R=OFUM, PROXY: [HEAD] and [SP]], how much / ALL OTHERS: How much] interest did [you / [they / he / she]] receive altogether in [PYEAR]?

- ENTER amount here, then SELECT unit of time on next screen (Month, Year)

→ GO TO W33 → GO TO W31F



W31EPER. The amount entered is: [W31E] per ____

- SELECT the unit of time below

W31F. During which months of [PYEAR] did you get this income?

- ENTER all that apply
- PROBE: Any others?

| | | | | | | |
|------------|-------------|--------------|-------------|--------------|--------------|---------|
| 1. January | 2. February | 3. March | 4. April | 5. May | 6. June | |
| 7. July | 8. August | 9. September | 10. October | 11. November | 12. December | 13. All |

W33. (Do you [or anyone in your family living there] have...)

Any other savings or assets, such as cash value in a life insurance policy, a valuable collection for investment purposes, or rights in a trust or estate that you haven't already told us about?

 → GO TO W38A



W34. If you sold that and paid off any debts on it, how much would you have?

→ GO TO W38A



| | |
|---|---|
| W35. Would it amount to \$10,000 or more? | |
| <input type="text" value="1. Yes"/> | <input type="text" value="5. No"/> <input type="text" value="DK/RF"/> → GO TO W38A |
| ↓ | ↓ |
| W36. \$25,000 or more? | W37. \$2,000 or more? |
| <input type="text" value="1. Yes"/> <input type="text" value="5. No"/> <input type="text" value="DK/RF"/> | <input type="text" value="1. Yes"/> <input type="text" value="5. No"/> <input type="text" value="DK/RF"/> |

Credit Card Debt

W38A. Aside from the debts that we have already talked about, [A23=YES MTGE: like any mortgage on your main home [F65/F67=YES VEH LOAN>0: [or / like] vehicle loans,]] do you [or anyone in your family living there] currently have any credit card or store card debt? Do not count new deb that will be paid off this month.

 → GO TO W38B



W39A. If you added up all credit card and store card debts [for all of your family living there], about how much would they amount to right now? (Please do not count any new debt that will be paid off this month.)

- INCLUDE unpaid balance(s) only, or credit card and store card debts that are outstanding

→ GO TO W38B



| | | |
|---|--|---|
| W40A. Would they amount to \$5,000 or more? | | |
| <input type="checkbox"/> 1. Yes | <input type="checkbox"/> 5. No | <input type="checkbox"/> DK/RF → GO TO W38B |
| ↓ | ↓ | |
| W41A. (Would they amount to) \$10,000 or more? | W42A. (Would they amount to) \$1,000 or more? | |
| <input type="checkbox"/> 1. Yes | <input type="checkbox"/> 5. No | <input type="checkbox"/> DK/RF |
| ↓ | GO TO W38B | |
| W43A. (Would they amount to) \$15,000 or more? | | |
| <input type="checkbox"/> 1. Yes | <input type="checkbox"/> 5. No | <input type="checkbox"/> DK/RF |

Student Loans, Medical Bills, Legal Bills, Loans From Relatives Debt

W38B. Do you [or anyone in your family living there] currently have any other debts such as student loans, medical or legal bills, or loans from relatives?

- ENTER all that apply
- PROBE: Any others?

| | | | |
|------------------|------------------|-----------------|-------------------------|
| 1. Student loans | 2. Medical bills | 3. Legal bills | 4. Loans from relatives |
| ASK W39B1-W43B1 | ASK W39B2-W43B2 | ASK W39B3-W43B3 | ASK W39B4-W43B4 |
| 5. No | 7. Other-specify | | |
| GO TO W43 | ASK W39B7-W43B7 | | |

W38B=Student Loans

W39B1. If you added up all student loans [for all of your family living there], about how much would they amount to right now?

- INCLUDE unpaid balance(s), or student loans that are outstanding

\$ 1 – 9,999,997

 → GO TO NEXT ITEM/W43 DK/RF

↓

| | | |
|--|--|--|
| W40B1. Would they amount to \$25,000 or more? | | |
| <input type="checkbox"/> 1. Yes | <input type="checkbox"/> 5. No | <input type="checkbox"/> DK/RF → GO TO NEXT ITEM/W43 |
| ↓ | ↓ | |
| W41B1. (Would they amount to) \$50,000 or more? | W42B1. (Would they amount to) \$10,000 or more? | |
| <input type="checkbox"/> 1. Yes | <input type="checkbox"/> 5. No | <input type="checkbox"/> DK/RF |
| ↓ | GO TO NEXT ITEM/W43 | |
| W43B1. (Would they amount to) \$75,000 or more? | | |
| <input type="checkbox"/> 1. Yes | <input type="checkbox"/> 5. No | <input type="checkbox"/> DK/RF |
| GO TO NEXT ITEM/W43 | | |

W38B= Medical Bills

W39B2. [*W38B=STUDENT LOANS*: How about medical bills (how much would they amount to right now) / *ALL OTHERS*: If you added up all medical bills [for all of your family living there], about how much would they amount to right now?]

- INCLUDE unpaid balance(s), or medical bills that are outstanding

→ GO TO NEXT ITEM/W43

↓

W40B2. Would they amount to \$3,000 or more?

→ GO TO NEXT ITEM/W43

↓

| | |
|--|---|
| <p>W41B2. (Would they amount to) \$10,000 or more?</p> <p><input type="text" value="1. Yes"/> <input type="text" value="5. No"/> <input type="text" value="DK/RF"/></p> <p style="text-align: center;">↓ GO TO NEXT ITEM/W43</p> | <p>W42B2. (Would they amount to) \$1,000 or more?</p> <p><input type="text" value="1. Yes"/> <input type="text" value="5. No"/> <input type="text" value="DK/RF"/></p> <p style="text-align: center;">↓ GO TO NEXT ITEM/W43</p> |
|--|---|

W43B2. (Would they amount to)
\$25,000 or more?

GO TO NEXT ITEM/W43

W38B= Legal Bills

W39B3. [*W38B=STUDENT LOANS, MEDICAL BILLS*: How about legal bills (how much would they amount to right now) / *ALL OTHERS*: If you added up all legal bills [for all of your family living there], about how much would they amount to right now?]

- INCLUDE unpaid balance(s), or legal bills that are outstanding

→ GO TO NEXT ITEM/W43

↓

W40B3. Would they amount to \$3,000 or more?

→ GO TO NEXT ITEM/W43

↓

| | |
|---|---|
| <p>W41B3. (Would they amount to) \$8,000 or more?</p> <p><input type="text" value="1. Yes"/> <input type="text" value="5. No"/> <input type="text" value="DK/RF"/></p> <p style="text-align: center;">↓ GO TO NEXT ITEM/W43</p> | <p>W42B3. (Would they amount to) \$1,000 or more?</p> <p><input type="text" value="1. Yes"/> <input type="text" value="5. No"/> <input type="text" value="DK/RF"/></p> <p style="text-align: center;">↓ GO TO NEXT ITEM/W43</p> |
|---|---|

W43B3. (Would they amount to)
\$20,000 or more?

GO TO NEXT ITEM/W43

W38B= Loans From Relatives

W39B4. [*W38B=STUDENT LOANS, MEDICAL BILLS, LEGAL BILLS*: How about loans from relatives (how much would they amount to right now) / *ALL OTHERS*: If you added up all loans from relatives [for all of your family living there], about how much would they amount to right now?]

- INCLUDE unpaid balance(s), or loans from relatives that are outstanding

→ GO TO NEXT ITEM/W43



| | | |
|---|---|--|
| W40B4. Would they amount to \$4,000 or more? | | |
| <input type="text" value="1. Yes"/> | <input type="text" value="5. No"/> | <input type="text" value="DK/RF"/> → GO TO NEXT ITEM/W43 |
| ↓ | ↓ | |
| W41B4. (Would they amount to) | W42B4. (Would they amount to) | |
| \$10,000 or more? | \$1,000 or more? | |
| <input type="text" value="1. Yes"/> <input type="text" value="5. No"/> <input type="text" value="DK/RF"/> | <input type="text" value="1. Yes"/> <input type="text" value="5. No"/> <input type="text" value="DK/RF"/> | |
| ↓ | ↓ | |
| GO TO NEXT ITEM/W43 | GO TO NEXT ITEM/W43 | |
| W43B4. (Would they amount to) | | |
| \$20,000 or more? | | |
| <input type="text" value="1. Yes"/> <input type="text" value="5. No"/> <input type="text" value="DK/RF"/> | | |
| GO TO NEXT ITEM/W43 | | |

W38B= Other

W39B7A. What were those other debts?

- Specify

W39B7. If you added up all other debts [for all of your family living there], about how much would they amount to right now?

- INCLUDE unpaid balance(s), or other debts that are outstanding

→ GO TO NEXT ITEM/W43



| | | |
|---|---|--|
| W40B7. Would they amount to \$4,000 or more? | | |
| <input type="text" value="1. Yes"/> | <input type="text" value="5. No"/> | <input type="text" value="DK/RF"/> → GO TO NEXT ITEM/W43 |
| ↓ | ↓ | |
| W41B7. (Would they amount to) | W42B7. (Would they amount to) | |
| \$10,000 or more? | \$1,000 or more? | |
| <input type="text" value="1. Yes"/> <input type="text" value="5. No"/> <input type="text" value="DK/RF"/> | <input type="text" value="1. Yes"/> <input type="text" value="5. No"/> <input type="text" value="DK/RF"/> | |
| ↓ | ↓ | |
| GO TO NEXT ITEM/W43 | GO TO NEXT ITEM/W43 | |
| W43B7. (Would they amount to) | | |
| \$20,000 or more? | | |
| <input type="text" value="1. Yes"/> <input type="text" value="5. No"/> <input type="text" value="DK/RF"/> | | |
| GO TO NEXT ITEM/W43 | | |

W43. These next questions are about changes in your wealth during the last two years. [R=HEAD, SP, OFUM: In these questions, when I refer to you I mean you and any family members living with you during that time.]
 Since January [P2YEAR], did you [or anyone in your family living there] put aside money in any private annuities or I.R.A.s (Individual Retirement Account)?

1. Yes 5. No → GO TO W48



W44. How much did that amount to?

\$ 1 – 999,999,997 → GO TO W48

DK/RF



| | |
|---|---|
| W45. Was it \$10,000 or more? | |
| <input type="checkbox"/> 1. Yes | <input type="checkbox"/> 5. No <input type="checkbox"/> DK/RF → GO TO W48 |
| ↓ | ↓ |
| W46. \$50,000 or more? | W47. \$5,000 or more? |
| <input type="checkbox"/> 1. Yes <input type="checkbox"/> 5. No <input type="checkbox"/> DK/RF | <input type="checkbox"/> 1. Yes <input type="checkbox"/> 5. No <input type="checkbox"/> DK/RF |

W48. (Since January [P2YEAR], did you [or anyone in your family living there]...)

Cash in any part of a pension, private annuity or I.R.A. (Individual Retirement Account)?

1. Yes 5. No → GO TO W54



W49. How much did that amount to?

\$ 1 – 999,999,997 → GO TO W54

DK/RF



| | |
|---|---|
| W50. Was it \$10,000 or more? | |
| <input type="checkbox"/> 1. Yes | <input type="checkbox"/> 5. No <input type="checkbox"/> DK/RF → GO TO W54 |
| ↓ | ↓ |
| W51. \$50,000 or more? | W53. \$5,000 or more? |
| <input type="checkbox"/> 1. Yes <input type="checkbox"/> 5. No <input type="checkbox"/> DK/RF | <input type="checkbox"/> 1. Yes <input type="checkbox"/> 5. No <input type="checkbox"/> DK/RF |
| ↓ | ↓ |
| GO TO W54 | GO TO W54 |
| W52. \$100,000 or more? | |
| <input type="checkbox"/> 1. Yes <input type="checkbox"/> 5. No <input type="checkbox"/> DK/RF | |

W54. (Since January [P2YEAR], did you [or anyone in your family living there]...)

Sell any home you were using as your main residence?

1. Yes 5. No → GO TO W59A



W55. About how much was the selling price, not including selling commissions and costs?

- IF R sold more than one main home, ask about the one owned in January, [P2YEAR]

\$ 1 – 999,999,997 → GO TO W59A

DK/RF



| | |
|---|---|
| W56. Was it \$60,000 or more? | |
| <input type="checkbox"/> 1. Yes | <input type="checkbox"/> 5. No <input type="checkbox"/> DK/RF → GO TO W59A |
| ↓ | ↓ |
| W57. \$120,000 or more? | W58. \$30,000 or more? |
| <input type="checkbox"/> 1. Yes <input type="checkbox"/> 5. No <input type="checkbox"/> DK/RF | <input type="checkbox"/> 1. Yes <input type="checkbox"/> 5. No <input type="checkbox"/> DK/RF |

W59A. (Since January [P2YEAR], did you [or anyone in your family living there]...)

Buy or sell any real estate other than your main home, such as a vacation home, land (not including farmland), or rental property?

- If R says only "Yes", PROBE: Did you buy only, sell only, or both?
- If needed: Real estate [A19=OWNS: other than [your main home,] such as a vacation home, land (not including farmland), or rental property

| | | | | |
|---------------------|-------------------|------------------------------|----------------|-------|
| 1. Yes, bought only | 2. Yes, sold only | 3. Yes, both bought and sold | 5. No, neither | DK/RF |
| ↓ | GO TO W65CKPT | ↓ | GO TO W65CKPT | |

W60. Altogether, how much money did you [or anyone in your family living there] spend on (real estate) (since January [P2YEAR])?

- If needed: Real estate [A19=OWNS: other than [your main home,] such as a vacation home, land (not including farmland), or rental property

| | | |
|--------------------|-----------------|-------|
| \$ 1 – 999,999,997 | → GO TO W65CKPT | DK/RF |
|--------------------|-----------------|-------|

↓

| | | | | | |
|-------------------------------|--|-----------------------------|------------------------|--------|-------|
| W61. Was it \$60,000 or more? | | | | | |
| 1. Yes | | 5. No DK/RF → GO TO W65CKPT | | | |
| ↓ | | ↓ | | | |
| W62. \$120,000 or more? | | | W63. \$30,000 or more? | | |
| 1. Yes | | 5. No | DK/RF | 1. Yes | |
| 5. No | | DK/RF | 5. No | | DK/RF |

W65CKPT. CAI Checkpoint: Whether Sold Only or Both Bought & Sold Real Estate

| | | |
|---|----------------------------------|-------------|
| 1. Sold Only/Both Bought & Sold (W59A=2, 3) | 5. All Others (W56A=1, 5, DK/RF) | → GO TO W69 |
| ↓ | | |

W65. Altogether, how much money you [or anyone in your family living there] get from selling real estate (since January [P2YEAR])?

- If needed: Real estate [A19=OWNS: other than [your main home,] such as a vacation home, land (not including farmland), or rental property

| | | |
|--------------------|-------------|-------|
| \$ 1 – 999,999,997 | → GO TO W69 | DK/RF |
|--------------------|-------------|-------|

↓

| | | | | | |
|-------------------------------|--|-------------------------|------------------------|--------|-------|
| W66. Was it \$60,000 or more? | | | | | |
| 1. Yes | | 5. No DK/RF → GO TO W69 | | | |
| ↓ | | ↓ | | | |
| W67. \$120,000 or more? | | | W68. \$30,000 or more? | | |
| 1. Yes | | 5. No | DK/RF | 1. Yes | |
| 5. No | | DK/RF | 5. No | | DK/RF |

W69. (Since January [P2YEAR], did you [or anyone in your family living there] ...)

Make additions or improvements totaling \$10,000 or more to any homes or other real estate [you / any of you] owned? Do not count general maintenance or upkeep.

1. Yes 5. No → GO TO W73A



W70. What was the total dollar cost of the additions or improvements, plus the value of any work you may have done yourself?

\$ 10,000 – 999,999,997 → GO TO W73A DK/RF



| | | |
|-------------------------------|-------|-------|
| W71. Was it \$25,000 or more? | | |
| 1. Yes | 5. No | DK/RF |
| ↓ GO TO W73A | | |
| W72. \$75,000 or more? | | |
| 1. Yes | 5. No | DK/RF |

W73A. (Since January [P2YEAR], did you [or anyone in your family living there] ...)

Put money into or sell part or all of your interest in a business or farm?

- If R says only “Yes”, **PROBE**: Did you put money in only, sell only, or both?

1. Yes, put money in only 2. Yes, sold only 3. Yes, both put money in and sold 5. No, neither DK/RF



GO TO W79CKPT



GO TO W79CKPT

W74. Altogether, how much money did you [or anyone in your family living there] put into a business or farm (since January [P2YEAR])?

\$ 1 – 999,999,997 → GO TO W79CKPT DK/RF



| | | | | | |
|-------------------------------|-------|------------------------|--------|-------|-------|
| W75. Was it \$25,000 or more? | | | | | |
| 1. Yes | 5. No | DK/RF → GO TO W79CKPT | | | |
| ↓ ↓ | | | | | |
| W76. \$100,000 or more? | | W77. \$10,000 or more? | | | |
| 1. Yes | 5. No | DK/RF | 1. Yes | 5. No | DK/RF |

W79CKPT. CAI Checkpoint: Whether Sold Only or Both Put Money In & Sold Farm/Business

| | | |
|---|----------------------------------|--------------|
| 1. Sold Only/Both Put In & Sold (W73A=2, 3) | 5. All Others (W73A=1, 5, DK/RF) | → GO TO W83A |
| ↓ | | |

W79. Altogether, how much money did you [or anyone in your family living there] get from selling a business or farm (since January [P2YEAR])?

\$ 1 – 999,999,997 → GO TO W83A DK/RF



| | | | | | |
|-------------------------------|-------|------------------------|--------|-------|-------|
| W80. Was it \$25,000 or more? | | | | | |
| 1. Yes | 5. No | DK/RF → GO TO W83A | | | |
| ↓ ↓ | | | | | |
| W81. \$100,000 or more? | | W82. \$10,000 or more? | | | |
| 1. Yes | 5. No | DK/RF | 1. Yes | 5. No | DK/RF |

W83A. (Since January [P2YEAR], did you [or anyone in your family living there] ...)

Buy or sell any shares of stock in publicly held corporations, stock mutual funds, or investment trusts, including any automatic reinvestments - not including any I.R.A.s (Individual Retirement Account)?

- If R says "Yes", PROBE: Did you buy only, sell only, or both?

| | | | | | |
|---------------------|-------------------|------------------------------|----------------|---------------|--|
| 1. Yes, bought only | 2. Yes, sold only | 3. Yes, both bought and sold | 5. No, neither | DK/RF | |
| ↓ | GO TO W97CKPT | | ↓ | GO TO W97CKPT | |

W91. Altogether, how much money did you [or anyone in your family living there] spend on (shares of) stocks (since January [P2YEAR])?

| | | |
|--------------------|-----------------|-------|
| \$ 1 – 999,999,997 | → GO TO W97CKPT | DK/RF |
|--------------------|-----------------|-------|

↓

| | | | | | |
|-------------------------------|--|-------|-----------------------|-----------------------|--|
| W92. Was it \$20,000 or more? | | | | | |
| 1. Yes | | 5. No | | DK/RF → GO TO W97CKPT | |
| ↓ | | ↓ | | | |
| W93. \$50,000 or more? | | | W95. \$5,000 or more? | | |
| 1. Yes | | 5. No | | DK/RF | |
| ↓ | | ↓ | | ↓ | |
| GO TO W97CKPT | | | GO TO W97CKPT | | |
| W94. \$100,000 or more? | | | | | |
| 1. Yes | | 5. No | | DK/RF | |

W97CKPT. CAI Checkpoint: Whether Sold Only or Both Bought & Sold Stock

| | | |
|---|----------------------------------|------------------|
| 1. Sold Only/Both Bought & Sold (W83A=2, 3) | 5. All Others (W83A=1, 5, DK/RF) | → GO TO W102CKPT |
| ↓ | | |

W97. Altogether, how much money did you [or anyone in your family living there] get from selling (shares of) stocks (since January [P2YEAR])?

| | | |
|--------------------|------------------|-------|
| \$ 1 – 999,999,997 | → GO TO W102CKPT | DK/RF |
|--------------------|------------------|-------|

↓

| | | | | | |
|-------------------------------|--|-------|------------------------|------------------------|--|
| W98. Was it \$20,000 or more? | | | | | |
| 1. Yes | | 5. No | | DK/RF → GO TO W102CKPT | |
| ↓ | | ↓ | | | |
| W99. \$50,000 or more? | | | W101. \$5,000 or more? | | |
| 1. Yes | | 5. No | | DK/RF | |
| ↓ | | ↓ | | ↓ | |
| GO TO W102CKPT | | | GO TO W102CKPT | | |
| W100. \$100,000 or more? | | | | | |
| 1. Yes | | 5. No | | DK/RF | |

W102CKPT. CAI Checkpoint: Whether There are Movers-Out Age 18+ Years Old (Family Listing)

| | | |
|-----------------------|---------------|------------------|
| 1. Movers-Out Age 18+ | 5. All Others | → GO TO W112CKPT |
| ↓ | | |

W102. Sometimes changes in a family's savings or assets are due to people joining or leaving the family. Was there anyone living with you in January [P2YEAR] who doesn't live with you now and who took \$5,000 or more in assets or debts away with them?

1. Yes 5. No → GO TO W112CKPT



W103. Altogether, what is the total dollar value of assets that were removed that way?

\$ 0 – 999,999,997 → GO TO W108

DK/RF



W104. Was it \$10,000 or more?

1. Yes



W105. \$25,000 or more?

1. Yes 5. No DK/RF



W106. \$100,000 or more?

1. Yes 5. No DK/RF

5. No DK/RF → GO TO W108



W107. \$5,000 or more?

1. Yes 5. No DK/RF

GO TO W108

W108. Altogether, what is the total dollar value of debts that were removed that way?

\$ 0 – 999,999,997 → GO TO W112CKPT

DK/RF



W109. Was it \$10,000 or more?

1. Yes



W110. \$25,000 or more?

1. Yes 5. No DK/RF

5. No DK/RF → GO TO W112CKPT



W111. \$5,000 or more?

1. Yes 5. No DK/RF

SIGNAL FOR W103 + W108 < \$ 5,000:

[Reported assets and debts removed total less than \\$5,000](#)

[Please verify amounts at W103 and W108](#)

W112CKPT. CAI Checkpoint: Whether There are Movers-In Age 18+ Years Old (Family Listing)

1. Movers-In Age 18+ 5. All Others → GO TO W123



W113. Is there anyone in your family living with you now who has joined the family since January [P2YEAR] and who had \$5,000 or more in assets or debts at the time they joined the family?

1. Yes 5. No → GO TO W123



W114. Altogether, what is the total dollar value of assets that were brought into the family that way?

→ GO TO W119



| | |
|---|---|
| W115. Was it \$10,000 or more? | |
| <input type="text" value="1. Yes"/> | <input type="text" value="5. No"/> <input type="text" value="DK/RF"/> → GO TO W119 |
| ↓ | ↓ |
| W116. \$25,000 or more? | W118. \$5,000 or more? |
| <input type="text" value="1. Yes"/> <input type="text" value="5. No"/> <input type="text" value="DK/RF"/> | <input type="text" value="1. Yes"/> <input type="text" value="5. No"/> <input type="text" value="DK/RF"/> |
| ↓ | ↓ |
| GO TO W119 | GO TO W119 |
| W117. \$100,000 or more? | |
| <input type="text" value="1. Yes"/> <input type="text" value="5. No"/> <input type="text" value="DK/RF"/> | |

W119. Altogether, what is the total dollar value of debts that were brought into the family that way?

→ GO TO W123



| | |
|---|---|
| W120. Was it \$10,000 or more? | |
| <input type="text" value="1. Yes"/> | <input type="text" value="5. No"/> <input type="text" value="DK/RF"/> → GO TO W123 |
| ↓ | ↓ |
| W121. \$25,000 or more? | W122. \$5,000 or more? |
| <input type="text" value="1. Yes"/> <input type="text" value="5. No"/> <input type="text" value="DK/RF"/> | <input type="text" value="1. Yes"/> <input type="text" value="5. No"/> <input type="text" value="DK/RF"/> |

SIGNAL FOR W114 + W119 < \$ 5,000:

[Reported assets and debts brought total less than \\$5,000](#)

[Please verify amounts at W114 and W119](#)

W123. Some people's assets come from gifts and inheritances. During the last two years, have you [or anyone in your family living there] received any large gifts or inheritances of money or property worth \$10,000 or more?

→ GO TO SECTION P



SECTION_W.W123A_W128[1-3] [1-3]=Which inheritance/gift

W123A. Was that a gift or was that an inheritance? If multiple gifts or inheritances worth \$10,000 or more were received, we can talk about each one separately.

W124A. What year did you [or anyone in your family living there] receive that? (If multiple gifts or inheritances worth \$10,000 or more were received, we can talk about each one separately.)

- [ENTER all that apply](#)
- [PROBE: Any others?](#)
- [ENTER \[7\] if it has not yet been received](#)



GO TO W128

W125. How much was [*W123A=1*: that gift / *W123A=2*: that inheritance / *ALL OTHERS*: it] worth altogether, at the time it was received? (If multiple gifts or inheritances worth \$10,000 or more were received, we can talk about each one separately.)

→ GO TO W128



| | | |
|--|------------------------------------|------------------------------------|
| W126. Would it amount to \$25,000 or more? | | |
| <input type="text" value="1. Yes"/> | <input type="text" value="5. No"/> | <input type="text" value="DK/RF"/> |
| ↓ | GO TO W128 | |
| W127. \$75,000 or more? | | |
| <input type="text" value="1. Yes"/> | <input type="text" value="5. No"/> | <input type="text" value="DK/RF"/> |

W128. Did you [or anyone in your family living there] receive any other large gifts or inheritances of money or property worth \$10,000 or more in the last two years?

→ Repeat W123A-W128; Max=3;
Then GO TO SECTION P



END W123A_W128
END SECTION_W

Section P: Pensions

[TOC](#)

SECTION_P

POCKPT1. CAI Checkpoint: Employment Status of Head

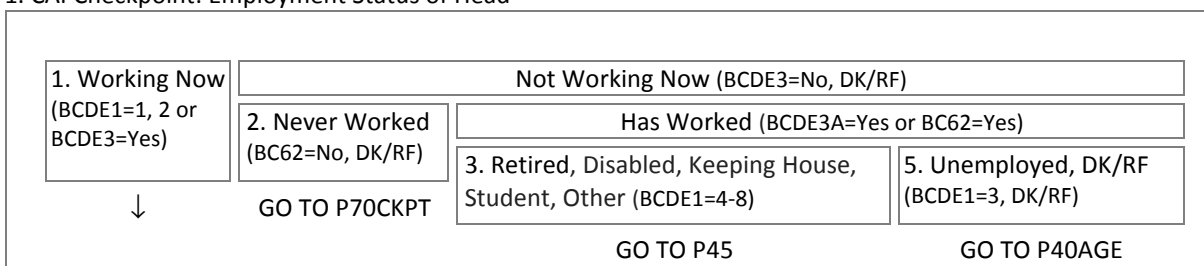

SECTION_P.SECTION_PDETAIL[1-2] [1]=Current Head, [2]=Current Spouse/Partner

PDETAILAQSN. AQSN of Current Head (Spouse/Partner)

P1. [CYAQRTH, CYNAMF CYNAML], Current Employer: [EMPNAME] ([BEG]-[END])

[1st ITERATION: Next, I need to get some information about pensions and retirement plans.] Not including Social Security, Railroad Retirement, or I.R.A.s (Individual Retirement Accounts), [are you / is [HEAD / SP]] participating in a pension or retirement plan through [your / his / her] present job [EMPLOYER NAME=RESPONSE: at [CMJ EMPLOYER]] [BC27=YES: , or through [your / his / her] union?]

- If R says “participating but hasn’t recently contributed”, ENTER [1]
- If R says “eligible but not participating”, ENTER [5]

1. Yes → GO TO P6CKPT 5. No DK/RF → GO TO P40AGE

↓

P1A. [CYAQRTH, CYNAMF CYNAML], Current Employer: [EMPNAME] ([BEG]-[END])

[Are you / Is [he / she]] currently eligible for such a plan?

1. Yes → GO TO P40AGE 5. No DK/RF → GO TO P40AGE

↓

P7. [CYAQRTH, CYNAMF CYNAML], Current Employer: [EMPNAME] ([BEG]-[END])

Will [you / he / she] become eligible for such a plan if [you / he / she] continue[s] to work for this employer?

1. Yes 5. No

GO TO P40AGE

P6CKPT. CAI Checkpoint: Whether Same CMJ as Last Wave (Section BC SAMECMJ)

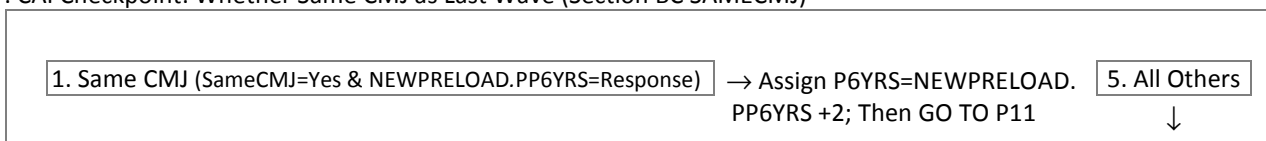
*Dependent Interviewing for Reinterviews*

P6YRS. [CYAQRTH, CYNAMF CYNAML], Plan Through Current Employer ([EMPNAME] ([BEG]-[END]))

How many years [have you / has [he / she]] been participating in this plan?

- ENTER [0] for “Less than one year”
- If R says there are multiple plans, PROBE: Please tell me about the plan [you have / [he / she] has] participated in the longest.
- ENTER number of years in pension or retirement plan or PRESS [ENTER] to go to the next screen to record the year started

[ENTER] 0 – 50 DK/RF

↓

GO TO P11

P6YR. [CYAQRTH, CYNAMF CYNAML], Plan Through Current Employer ([EMPNAME] ([BEG]-[END]))

(In which year did [you / he / she] start participating in this plan?)

- If R says there are multiple plans, PROBE: Please tell me about the plan [you have / [he / she] has] participated in the longest.
- ENTER year started in pension or retirement plan

[1901 – [CYEAR]]

P11. [CYAQRTH, CYNAMF CYNAML], Plan Through Current Employer ([EMPNAME] ([BEG]-[END]))

[Are you / Is [he / she]] making any contributions to [your / his / her] pension or retirement account such as having money deducted from your [your / his / her] pay?

1. Yes 5. No → GO TO P16

↓

P12. [CYAQRTH, CYNAMF CYNAML], Plan Through Current Employer ([EMPNAME] ([BEG]-[END]))

[Are you / Is [he / she]] required to contribute?

1. Yes 5. No → GO TO P15AMT

↓

P13AMT. [CYAQRTH, CYNAMF CYNAML], Plan Through Current Employer ([EMPNAME] ([BEG]-[END]))

What amount or percent of pay [are you / is [he / she]] required to contribute?

- ENTER dollar amount here, then SELECT unit of time on next screen (Week, Two weeks, Month, Year)
- OR press [ENTER] to continue to next screen for Percent

[ENTER] → GO TO P13PCT \$ 1 – 9,999,997 DK/RF → GO TO P14

↓

P13PER. The amount entered is: [P13AMT] per ____

- SELECT the unit of time below

3. Week 4. Two weeks 5. Month 6. Year

7. Other-specify (P13PERSPEC. Specify. (String 100))

GO TO P14

P13PCT. [CYAQRTH, CYNAMF CYNAML], Plan Through Current Employer ([EMPNAME] ([BEG]-[END]))

(What percent of pay [are you / is [he / she]] required to contribute?)

- ENTER a percentage from 1.0 to 25.0

[1.0 – 25.0]

P14. [CYAQRTH, CYNAMF CYNAML], Plan Through Current Employer ([EMPNAME] ([BEG]-[END]))

[Do you / Does [he / she]] also make voluntary contributions?

1. Yes 5. No → GO TO P16

↓

P15AMT. [CYAQRTH, CYNAMF CYNAML], Plan Through Current Employer ([EMPNAME] ([BEG]-[END]))

What amount or percent of pay [do you / does [he / she]] voluntarily contribute currently?

- ENTER dollar amount here, then SELECT unit of time on next screen (Week, Two weeks, Month, Year)
- OR press [ENTER] to continue to next screen for Percent

[ENTER] → GO TO P15PCT \$ 1 – 9,999,997 DK/RF → GO TO P16

↓

P15PER. The amount entered is: [P15AMT] per ____

- SELECT the unit of time below

| | | | |
|--|--------------|----------|---------|
| 3. Week | 4. Two weeks | 5. Month | 6. Year |
| 7. Other-specify (P15PERSPEC. Specify. (String 100)) | | | |

GO TO P16

P15PCT. [CYAQRTH, CYNAMF CYNAML], Plan Through Current Employer ([EMPNAME] ([BEG]-[END]))
(What percent of pay [do you / does [he / she]] voluntarily contribute currently?)

- ENTER a percentage from 1.0 to 50.0

1.0 – 50.0

P16. [CYAQRTH, CYNAMF CYNAML], Plan Through Current Employer ([EMPNAME] ([BEG]-[END]))

HEAD; SP AND HEAD NOT ASKED: Some pension and-retirement plans base benefits on a formula involving age, years of service and salary, often called a defined benefit plan. Some plans, such as a 401K, base benefits on how much money has accumulated in a person's pension or retirement account, often called a defined contribution plan. Other plans use both ways of setting benefits.

SP & HEAD ALSO ASKED: (Some pension and-retirement plans base benefits on a formula involving age, years of service and salary, often called a defined benefit plan. Some, such as a 401K, plans base benefits on how much money has accumulated in a person's pension or retirement account, often called a defined contribution plan. Other plans use both ways of setting benefits.)

What type of plan [do you / does [HEAD / SP]] have?

- Defined Contribution plans include 401-K, 403-B, ESOP, SRA, thrift/savings, stock/profit sharing, money purchase plans, and target date funds (TDF)

| | | | | |
|--|--|---------|-------|-----------------|
| 1. Defined benefit plan GO TO P22CKPT | 5. Defined contribution plan / Money accumulated in account | 7. Both | DK/RF | → GO TO P22CKPT |
|--|--|---------|-------|-----------------|



Defined Contribution (P16=DC Only or Both)

P17. [CYAQRTH, CYNAMF CYNAML], Plan Through Current Employer ([EMPNAME] ([BEG]-[END]))

Does [your / his / her] employer make contributions to [your / his / her] account?

1. Yes 5. No → GO TO P20



P18AMT. [CYAQRTH, CYNAMF CYNAML], Plan Through Current Employer ([EMPNAME] ([BEG]-[END]))

What amount or percent of pay does [your / his / her] employer contribute to [your / his / her] account?

- ENTER dollar amount here, then SELECT unit of time on next screen (Week, Two weeks, Month, Year)
- OR press [ENTER] to continue to next screen for Percent of pay or Percent of employee contribution

[ENTER] → GO TO P18PCT \$ 1 – 9,999,997 DK/RF → GO TO P19CKPT



P18PER. The amount entered is: [P18AMT] per ____

- SELECT the unit of time below

| | | | |
|--|--------------|----------|---------|
| 3. Week | 4. Two weeks | 5. Month | 6. Year |
| 7. Other-specify (P18PERSPEC. Specify. (String 100)) | | | |

GO TO P19CKPT

Defined Contribution (P16=DC Only or Both)

P18PCT. [CYAQRTH, CYNAMF CYNAML], Plan Through Current Employer ([EMPNAME] ([BEG]-[END]))

(What percent of pay does [your / his / her] employer contribute to [your / his / her] account?)

- ENTER a percentage of pay from 1.0 to 25.0
- OR press [ENTER] to continue to next screen for Percent of employee contribution

| | | |
|---------|------------|-------|
| [ENTER] | 1.0 – 25.0 | DK/RF |
|---------|------------|-------|

↓
GO TO P19CKPT

P18PCTB. [CYAQRTH, CYNAMF CYNAML], Plan Through Current Employer ([EMPNAME] ([BEG]-[END]))

(What percent of [your / his / her] contribution does [your / his / her] employer contribute to [your / his / her] account?)

- ENTER a percentage of employee contribution from 1.0 to 200.0

| |
|-------------|
| 1.0 – 200.0 |
|-------------|

P19CKPT. CAI Checkpoint: Whether Head (Spouse/Partner) is 40 Years Old or Older

| | |
|------------------------------------|---------------------------|
| 1. Age 40 or Older (AGEIWDATE=40+) | 5. All Others → GO TO P20 |
| ↓ | |

P19. [CYAQRTH, CYNAMF CYNAML], Plan Through Current Employer ([EMPNAME] ([BEG]-[END]))

At what age could [you / he / she] first receive retirement benefits that include [your / his / her] employer's contributions?

| |
|----------|
| 31 – 100 |
|----------|

Defined Contribution (P16=DC Only or Both)

P20. [CYAQRTH, CYNAMF CYNAML], Plan Through Current Employer ([EMPNAME] ([BEG]-[END]))

What is the approximate dollar amount in [your / his / her] account now?

| |
|---------------------------------|
| \$ 1 – 999,999,997 → GO TO P20A |
|---------------------------------|

| |
|-------|
| DK/RF |
|-------|

↓

P20B. Is it \$25,000 or more?

| |
|--------|
| 1. Yes |
|--------|

↓

P20C. \$75,000 or more?

| | | |
|--------|-------|-------|
| 1. Yes | 5. No | DK/RF |
|--------|-------|-------|

↓

GO TO P20A

P20D. \$200,000 or more?

| | | |
|--------|-------|-------|
| 1. Yes | 5. No | DK/RF |
|--------|-------|-------|

| | | |
|-------|-------|--------------|
| 5. No | DK/RF | → GO TO P20A |
|-------|-------|--------------|

↓

P20E. \$5,000 or more?

| | | |
|--------|-------|-------|
| 1. Yes | 5. No | DK/RF |
|--------|-------|-------|

GO TO P20A

Defined Contribution (P16=DC Only or Both)

P20A. [CYAQRTH, CYNAMF CYNAML], Plan Through Current Employer ([EMPNAME] ([BEG]-[END]))

Are the funds invested mostly in stocks and stock mutual funds, mostly in bonds, bond mutual funds and annuities, or some of each?

| | | |
|---------------------------|-----------------|--|
| 1. Mostly (or all) stocks | 2. Some of each | 3. Mostly (or all) bonds and annuities |
|---------------------------|-----------------|--|

P22CKPT. CAI Checkpoint: Type of Pension; Whether Head (Spouse/Partner) is 40 Years Old or Older

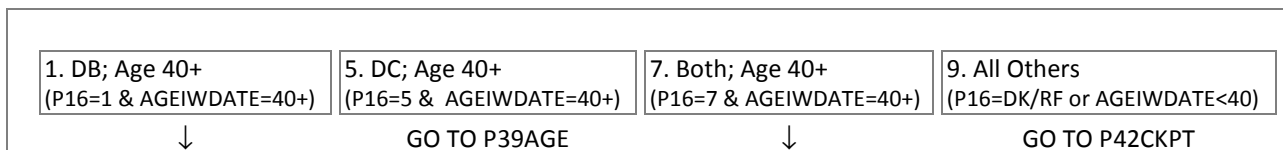
Defined Benefit Age 40+ (P16=DB Only or Both)

P22A. [CYAQRTH, CYNAMF CYNAML], Plan Through Current Employer ([EMPNAME] ([BEG]-[END]))

[P16=BOTH: For the part of [your / his/ her] pension or retirement plan where benefits are based on a formula, what / ALL OTHERS: What] is the earliest age at which [you / he / she] would be eligible to receive “full” or “normal” pension or retirement benefits?

- ENTER number of years; ENTER months at next screen
- ENTER [997] for Any time; any age; no age requirement
- If R says “already eligible”, PROBE: What is the earliest age at which [you / he / she] would have been eligible (to receive full” or “normal” pension or retirement benefits)?

| | | |
|----------|---|--------|
| 31 – 100 | 997. Any time; any age; no age requirement (IF VOL) | DK /RF |
| ↓ | GO TO P22C | |

P22B. [CYAQRTH, CYNAMF CYNAML], Plan Through Current Employer ([EMPNAME] ([BEG]-[END]))

([P16=BOTH: (For the part of [your / his/ her] pension or retirement plan where benefits are based on a formula,) what / ALL OTHERS: What] is the earliest age at which [you / he / she] would be eligible to receive “full” or “normal” pension or retirement benefits?)

- ENTER number of months; PRESS [ENTER] for no months

| |
|--------|
| 1 – 11 |
|--------|

Defined Benefit Age 40+ (P16=DB Only or Both)

P22C. [CYAQRTH, CYNAMF CYNAML], Plan Through Current Employer ([EMPNAME] ([BEGMO/BEGYR]-[ENDMO/ENDYR]))

[P16=BOTH: (For the part of [your / his/ her] pension or retirement plan where benefits are based on a formula,) what / ALL OTHERS: What] is the earliest age at which [you / he / she] could leave [your / his / her] employer and receive any (pension or retirement) benefits immediately?

- ENTER number of years; ENTER months at next screen
- ENTER [997] for Any time; any age; no age requirement
- If R says “already eligible”, PROBE: What is the earliest age at which [you / he / she] could have done so (leave [your / his / her] employer and receive any (pension or retirement) benefits immediately)?

| | | |
|----------|---|--------|
| 31 – 100 | 997. Any time; any age; no age requirement (IF VOL) | DK /RF |
| ↓ | GO TO P32 | |

P22D. [CYAQRTH, CYNAMF CYNAML], Plan Through Current Employer ([EMPNAME] ([BEG]-[END]))

([P16=BOTH: (For the part of [your / his/ her] pension or retirement plan where benefits are based on a formula,) what / ALL OTHERS: What] is the earliest age at which [you / he / she] could leave [your / his / her] employer and receive any (pension or retirement) benefits immediately?)

- ENTER number of months; PRESS [ENTER] for no months

| |
|--------|
| 1 – 11 |
|--------|

Defined Benefit Age 40+ (P16=DB Only or Both)

P32. [CYAQRTH, CYNAMF CYNAML], Plan Through Current Employer ([EMPNAME] ([BEG]-[END]))

[P16=BOTH: (For the part of [your / his/ her] pension or retirement plan where benefits are based on a formula,) at / ALL OTHERS: At] what age [do you / does [he / she]] expect to start receiving retirement benefits from this pension or retirement plan?

- ENTER [997] for Never; won't stay long enough

| | | |
|-------------------------|------------------------------------|-------|
| [CURRENT AGE (18)] – 95 | 997. Never; won't stay long enough | DK/RF |
|-------------------------|------------------------------------|-------|

↓
GO TO P39AGE

Defined Benefit Age 40+ (P16=DB Only or Both)

P34AMT. [CYAQRTH, CYNAMF CYNAML], Plan Through Current Employer ([EMPNAME] ([BEG]-[END]))

[P16=BOTH: (For the part of [your / his/ her] pension or retirement plan where benefits are based on a formula,) how / ALL OTHERS: How] much [do you / does [he / she]] expect to receive (either as a percent of [your / his / her] pay at retirement or as an amount per month or year)?

- ENTER dollar amount here, then SELECT unit of time on next screen (Month, Year)
- OR press [ENTER] to continue to next screen for Percent

| | | | | |
|---------|----------------|------------------|-------|--------------|
| [ENTER] | → GO TO P34PCT | \$ 1 – 9,999,997 | DK/RF | → GO TO P34F |
|---------|----------------|------------------|-------|--------------|

↓

P34PER. The amount entered is: [P34AMT] per ____

- SELECT the unit of time below

| | | |
|----------|---------|--|
| 5. Month | 6. Year | 7. Other-specify (P34PERSPEC. Specify. (String 100)) |
|----------|---------|--|

GO TO P39AGE

Defined Benefit Age 40+ (P16=DB Only or Both)

P34PCT. [CYAQRTH, CYNAMF CYNAML], Plan Through Current Employer ([EMPNAME] ([BEG]-[END]))

([P16=BOTH: (For the part of [your / his/ her] pension or retirement plan where benefits are based on a formula,) how / ALL OTHERS: How] much [do you / does [he / she]] expect to receive (as a percent of [your / his / her] pay at retirement)?)

- ENTER a percentage from 1.0 to 100.0

| | | |
|-------------|----------------|-------|
| 1.0 – 100.0 | → GO TO P39AGE | DK/RF |
|-------------|----------------|-------|

↓

P34F. Will it be 40% of [your / his / her] pay or more?

| | | | |
|--------|-------|-------|----------------|
| 1. Yes | 5. No | DK/RF | → GO TO P39AGE |
|--------|-------|-------|----------------|

↓

P34G. 60% or more (of [your / his / her] pay)?

| | | |
|--------|-------|-------|
| 1. Yes | 5. No | DK/RF |
|--------|-------|-------|

↓
GO TO P39AGE

P34J. 20% or more (of [your / his / her] pay)?

| | | |
|--------|-------|-------|
| 1. Yes | 5. No | DK/RF |
|--------|-------|-------|

GO TO P39AGE

P34H. 80% or more (of [your / his / her] pay)?

| | | |
|--------|-------|-------|
| 1. Yes | 5. No | DK/RF |
|--------|-------|-------|

Defined Benefit or Contribution Age 40+ (P16=DB Only, DC Only, or Both)

P39AGE. [CYAQRTH, CYNAMF CYNAML], Plan Through Current Employer ([EMPNAME] ([BEG]-[END]))

On [your / his / her] present job [*EMPLOYER NAME IS RESPONSE*: at [CMJ EMPLOYER]], what is the usual retirement age (or years of service) for people who work with [you / him / her] or have the same kind of job?

- ENTER usual age of retirement or press [ENTER] to continue to next screen for years of service

[ENTER] 20 – 75 → GO TO P40AGE DK/RF

↓

↓

P39YRS. [CYAQRTH, CYNAMF CYNAML], Plan Through Current Employer ([EMPNAME] ([BEG]-[END]))

(What is the usual number of years of service for retirement?)

- ENTER number of years

1 – 50

Defined Benefit or Contribution Age 40+ (P16=DB Only, DC Only, or Both) or P0CKPT1/P70ACKPT1=5

P40AGE. [CYAQRTH, CYNAMF CYNAML], Plan Through Current Employer ([EMPNAME] ([BEG]-[END]))

Now I want to ask about [your / [HEAD / SP]'s] plans for retirement. At what age [do you / does [he / she]] plan to stop working?

- ENTER age or press [ENTER] to continue to next screen for number of years
- ENTER [996] for Already stopped working
- ENTER [997] for Never

[ENTER] [CURRENT AGE] - 95 996. Already stopped working 997. Never DK/RF

↓

GO TO P42CKPT

P40NUM. [CYAQRTH, CYNAMF CYNAML], Plan Through Current Employer ([EMPNAME] ([BEG]-[END]))

(In how many years [do you / does [he / she]] plan to stop working?)

- ENTER number of years

1 – 50 DK/RF

P42CKPT. CAI Checkpoint: Employment Status of Head (Spouse/Partner) (Section BC)

1. Working Now (BCDE1=1, 2 Or BCDE3=Yes) 5. All Others → GO TO P45

↓

P42. [CYAQRTH, CYNAMF CYNAML], Other Plan(s) Through Current Employer ([EMPNAME] ([BEG]-[END]))

[P1=YES: In addition to the pension or retirement plan you already mentioned, [do you / does [HEAD / SP]] / *ALL OTHERS*: [Do you / Does [HEAD / SP]]] have any tax-deferred compensation or savings plans on [your / his / her] present job, such as a "thrift", profit-sharing, or Keogh plan?

1. Yes 5. No → GO TO P45

↓

P43. [CYAQRTH, CYNAMF CYNAML], Other Plan(s) Through Current Employer ([EMPNAME] ([BEG]-[END]))

Does [your / his / her] employer make contributions to any such plan for [you / him / her]?

1. Yes 5. No → GO TO P45

↓

P44AMT. [CYAQRTH, CYNAMF CYNAML], Other Plan(s) Through Current Employer ([EMPNAME] ([BEG]-[END]))

What amount or percent of pay does [your / his / her] employer contribute?

- ENTER dollar amount here, then SELECT unit of time on next screen (Week, Two weeks, Month, Year)
- OR press [ENTER] to continue to next screen for Percent of pay or Percent of employee contribution

[ENTER] → GO TO P44PCT \$ 1 – 9,999,997 DK/RF → GO TO P45

↓

P44PER. The amount entered is: [P44AMT] per ____

- SELECT the unit of time below

3. Week 4. Two weeks 5. Month 6. Year

7. Other-specify (P44PERSPEC. Specify. (String 100))

GO TO P45

P44PCT. [CYAQRTH, CYNAMF CYNAML], Other Plan(s) Through Current Employer ([EMPNAME] ([BEG]-[END]))

(What percent of pay does [your / his / her] employer contribute?)

- ENTER a percentage of pay from 1.0 to 25.0
- OR press [ENTER] to continue to next screen for Percent of employee contribution

[ENTER] 1.0 – 25.0 DK/RF

↓

GO TO P45

P44PCTB. [CYAQRTH, CYNAMF CYNAML], Other Plan(s) Through Current Employer ([EMPNAME] ([BEG]-[END]))

(What percent of [your / his / her] contribution does [your / his / her] employer contribute?)

- ENTER a percentage of employee contribution from 1.0 to 200.0

1.0 – 200.0

SECTION_P.SECTION_PDETAIL[1-2].P45_P69[1-2] [1]=Current Head, [2]=Current Spouse/Partner; [1-2]=Which plan

P45. [CYAQRTH, CYNAMF CYNAML]

[LOOP 2 & SP NOT WORKING NOW: (These next questions are about [your / [SP]'s] pensions or retirement plans through a former employer.) / ALL OTHERS: These next questions are about [your / [HEAD / SP]'s] pensions or retirement plans through a former employer.]

Aside from I.R.A. (Individual Retirement Account) or Keogh Plans already reported, [do you / does [HEAD / SP]] have any pensions or retirement plans from previous employers from which [you / he / she] [G40/G61

=RETIREMENT, PENSION, IRA: [have / has] not begun to receive regular benefit payments but] expect[s] to receive benefits?

1. Yes 5. No → GO TO P70CKPT

↓

P45A. [CYAQRTH, CYNAMF CYNAML]

How many such (pension or retirement) plans (through a former employer) [do you / does [he / she]] have from which [you / he /she] expect[s] to receive benefits?

1 – 5

P46. [CYAQRTH, CYNAMF CYNAML], Plan #[1 / 2] Through a Former Employer

1st PREVIOUS PENSION, P1=YES: [1st ITERATION: What type of plan was this second pension or retirement plan? A defined benefit plan that bases benefits on a formula involving age, years of service and salary, or a defined contribution plan, such as a 401K, that bases benefits on how much money has accumulated in a person's pension or retirement account? / 2nd ITERATION: What type of plan was this second pension or retirement plan? (A defined benefit plan that bases benefits on a formula involving age, years of service and salary, or a defined contribution plan, such as a 401K, that bases benefits on how much money has accumulated in a person's pension or retirement account?)]

1st PREVIOUS PENSION, P1<>YES: [1st ITERATION: I would like to know what type of plan this was. Was it a defined benefit plan that bases benefits on a formula involving age, years of service and salary, or a defined contribution plan, such as a 401K, that bases benefits on how much money has accumulated in a person's pension or retirement account? / 2nd ITERATION: I would like to know what type of plan this was. (Was it a defined benefit plan that bases benefits on a formula involving age, years of service and salary, or a defined contribution plan, such as a 401K, that bases benefits on how much money has accumulated in a person's pension or retirement account?)]

2nd PREVIOUS PENSION: I would like to know what type of plan this was. (Was it a defined benefit plan that bases benefits on a formula involving age, years of service and salary, or a defined contribution plan, such as a 401K, that bases benefits on how much money has accumulated in a person's pension or retirement account?)

- [P45A>1 PLAN: If needed: Tell us about the [P46 LOOP 2: next] most important plan]
- **Defined Contribution plans include 401-K, 403-B, ESOP, SRA, thrift/savings, stock/profit sharing, money purchase plans, and target date funds (TDF)**

| | | | | |
|-------------------------|------------------------------|---------|-----------|---------------|
| 1. Defined benefit plan | 5. Defined contribution plan | 7. Both | DK | RF |
| GO TO P52 | GO TO P62ACKPT | ↓ | GO TO P52 | GO TO P70CKPT |

Defined Contribution (P46=Both)

P47. [CYAQRTH, CYNAMF CYNAML], Plan #[1 / 2] Through a Former Employer

For the part of [your / his / her] pension or retirement plan where money is accumulated in an account, how much money was in [your / his / her] account when [you / he / she] left that employer?

| | | | | | | | | | | | | | | | | | | | | | | | | | | | | | | | |
|--|-------------------------|--------------------------------|--|--------|-------------------------|---|--|--|--|--------------------------|--|--------|-------------|---|--|--|--|--------------------------|--|--------|-------------|--|--|------------------------|--|--------|-------------|---|--|-----------|--|
| \$ 0 – 99,999,997 → GO TO P48 | DK/RF | | | | | | | | | | | | | | | | | | | | | | | | | | | | | | |
| ↓ | | | | | | | | | | | | | | | | | | | | | | | | | | | | | | | |
| <table border="1"> <tr> <td colspan="2">P47B. Was it \$20,000 or more?</td> </tr> <tr> <td>1. Yes</td> <td>5. No DK/RF → GO TO P48</td> </tr> <tr> <td colspan="2" style="text-align: center;">↓</td> </tr> <tr> <td colspan="2"> <table border="1"> <tr> <td colspan="2">P47C. \$50,000 or more?</td> </tr> <tr> <td>1. Yes</td> <td>5. No DK/RF</td> </tr> <tr> <td colspan="2" style="text-align: center;">↓</td> </tr> <tr> <td colspan="2"> <table border="1"> <tr> <td colspan="2">P47D. \$150,000 or more?</td> </tr> <tr> <td>1. Yes</td> <td>5. No DK/RF</td> </tr> </table> </td> </tr> </table> </td> </tr> <tr> <td colspan="2"> <table border="1"> <tr> <td colspan="2">P47E. \$5,000 or more?</td> </tr> <tr> <td>1. Yes</td> <td>5. No DK/RF</td> </tr> <tr> <td colspan="2" style="text-align: center;">↓</td> </tr> <tr> <td colspan="2">GO TO P48</td> </tr> </table> </td> </tr> </table> | | P47B. Was it \$20,000 or more? | | 1. Yes | 5. No DK/RF → GO TO P48 | ↓ | | <table border="1"> <tr> <td colspan="2">P47C. \$50,000 or more?</td> </tr> <tr> <td>1. Yes</td> <td>5. No DK/RF</td> </tr> <tr> <td colspan="2" style="text-align: center;">↓</td> </tr> <tr> <td colspan="2"> <table border="1"> <tr> <td colspan="2">P47D. \$150,000 or more?</td> </tr> <tr> <td>1. Yes</td> <td>5. No DK/RF</td> </tr> </table> </td> </tr> </table> | | P47C. \$50,000 or more? | | 1. Yes | 5. No DK/RF | ↓ | | <table border="1"> <tr> <td colspan="2">P47D. \$150,000 or more?</td> </tr> <tr> <td>1. Yes</td> <td>5. No DK/RF</td> </tr> </table> | | P47D. \$150,000 or more? | | 1. Yes | 5. No DK/RF | <table border="1"> <tr> <td colspan="2">P47E. \$5,000 or more?</td> </tr> <tr> <td>1. Yes</td> <td>5. No DK/RF</td> </tr> <tr> <td colspan="2" style="text-align: center;">↓</td> </tr> <tr> <td colspan="2">GO TO P48</td> </tr> </table> | | P47E. \$5,000 or more? | | 1. Yes | 5. No DK/RF | ↓ | | GO TO P48 | |
| P47B. Was it \$20,000 or more? | | | | | | | | | | | | | | | | | | | | | | | | | | | | | | | |
| 1. Yes | 5. No DK/RF → GO TO P48 | | | | | | | | | | | | | | | | | | | | | | | | | | | | | | |
| ↓ | | | | | | | | | | | | | | | | | | | | | | | | | | | | | | | |
| <table border="1"> <tr> <td colspan="2">P47C. \$50,000 or more?</td> </tr> <tr> <td>1. Yes</td> <td>5. No DK/RF</td> </tr> <tr> <td colspan="2" style="text-align: center;">↓</td> </tr> <tr> <td colspan="2"> <table border="1"> <tr> <td colspan="2">P47D. \$150,000 or more?</td> </tr> <tr> <td>1. Yes</td> <td>5. No DK/RF</td> </tr> </table> </td> </tr> </table> | | P47C. \$50,000 or more? | | 1. Yes | 5. No DK/RF | ↓ | | <table border="1"> <tr> <td colspan="2">P47D. \$150,000 or more?</td> </tr> <tr> <td>1. Yes</td> <td>5. No DK/RF</td> </tr> </table> | | P47D. \$150,000 or more? | | 1. Yes | 5. No DK/RF | | | | | | | | | | | | | | | | | | |
| P47C. \$50,000 or more? | | | | | | | | | | | | | | | | | | | | | | | | | | | | | | | |
| 1. Yes | 5. No DK/RF | | | | | | | | | | | | | | | | | | | | | | | | | | | | | | |
| ↓ | | | | | | | | | | | | | | | | | | | | | | | | | | | | | | | |
| <table border="1"> <tr> <td colspan="2">P47D. \$150,000 or more?</td> </tr> <tr> <td>1. Yes</td> <td>5. No DK/RF</td> </tr> </table> | | P47D. \$150,000 or more? | | 1. Yes | 5. No DK/RF | | | | | | | | | | | | | | | | | | | | | | | | | | |
| P47D. \$150,000 or more? | | | | | | | | | | | | | | | | | | | | | | | | | | | | | | | |
| 1. Yes | 5. No DK/RF | | | | | | | | | | | | | | | | | | | | | | | | | | | | | | |
| <table border="1"> <tr> <td colspan="2">P47E. \$5,000 or more?</td> </tr> <tr> <td>1. Yes</td> <td>5. No DK/RF</td> </tr> <tr> <td colspan="2" style="text-align: center;">↓</td> </tr> <tr> <td colspan="2">GO TO P48</td> </tr> </table> | | P47E. \$5,000 or more? | | 1. Yes | 5. No DK/RF | ↓ | | GO TO P48 | | | | | | | | | | | | | | | | | | | | | | | |
| P47E. \$5,000 or more? | | | | | | | | | | | | | | | | | | | | | | | | | | | | | | | |
| 1. Yes | 5. No DK/RF | | | | | | | | | | | | | | | | | | | | | | | | | | | | | | |
| ↓ | | | | | | | | | | | | | | | | | | | | | | | | | | | | | | | |
| GO TO P48 | | | | | | | | | | | | | | | | | | | | | | | | | | | | | | | |

Defined Contribution (P46=Both)

P48. [CYAQRTH, CYNAMF CYNAML], Plan #[1 / 2] Through a Former Employer

When [you / he / she] left that employer, did [you / he / she] withdraw this money, roll it over into an I.R.A. (Individual Retirement Account), leave it to accumulate in the old plan, convert it to an annuity, or what?

- **IF more than one response given, ENTER [7] and record all details**

| | | | | | |
|-----------------------|----------------------------|-----------------------|-------------------------|---|-------|
| 1. Withdrew the money | 2. Rolled over into I.R.A. | 3. Left to accumulate | 4. Converted to annuity | 7. Other-specify (P48SPEC. Specify. (String 100)) | DK/RF |
| GO TO P52 | ↓ | | GO TO P50 | GO TO P52 | |

P49. [CYAQRTH, CYNAMF CYNAML], Plan #[1 / 2] Through a Former Employer

How much is in [your / his / her] account now?

 → GO TO P52

P49B. Is it \$50,000 or more?



P49C. \$100,000 or more?

GO TO P52

P49D. \$200,000 or more?

GO TO P52

 → GO TO P52

P49E. \$20,000 or more?

GO TO P52

Defined Contribution (P46=Both)

P50. [CYAQRTH, CYNAMF CYNAML], Plan #[1 / 2] Through a Former Employer

How old [were you / was [he / she]] when [you / he / she] started receiving the benefits from that annuity?

- IF benefits have not yet begun, PROBE: At what age will [you / he / she] begin receiving them?

Defined Contribution (P46=Both)

P51. [CYAQRTH, CYNAMF CYNAML], Plan #[1 / 2] Through a Former Employer

How much are the annuity benefits per month or year?

- IF benefits have not yet begun, PROBE: What will the benefits be once [you / he / she] begin[s] receiving them?
- ENTER dollar amount here, then SELECT unit of time on next screen (Month, Year)

 → GO TO P51B

P51PER. The amount entered is: [P51] per ____

- SELECT the unit of time below

GO TO P52

P51B. Are they \$400 or more per month?



P51C. \$1,200 or more (per month)?

GO TO P52

P51D. \$1,600 or more (per month)?

 → GO TO P52

P51E. \$200 or more (per month)?

GO TO P52

Defined Benefit (P46=DB Only or Both)

P52. [CYAQRTH, CYNAMF CYNAML], Plan #[1 / 2] Through a Former Employer

[P46=BOTH: Now about the part of [your / his / her] pension or retirement plan where benefits are based on a formula. / ALL OTHERS: (Now about the part of [your / his / her] pension or retirement plan where benefits are based on a formula.)]

[Do you / Does [HEAD / SP]] expect to receive benefits from this plan in the future, [are you / is [he / she]] receiving benefits now, did [you / he / she] get a cash settlement when [you / he / she] left, did [you / he / she] lose [your / his / her] benefits, or what?

- DO NOT PROBE for multiple responses but ENTER all that apply.

| | | | |
|--|--|--|--|
| 1. Expect future benefits ASK P60-P69 | 2. Receiving benefits now ASK P53YR-P56 | 3. Received cash settlement ASK P57-P58 | 4. Rolled over into I.R.A. ASK P59-P59E |
| 5. Lost benefits | Other-specify (P52SPEC. Specify. (String 100)) | | DK/RF |

GO TO P69

P52ACKPT. CAI Checkpoint: Whether Receiving Benefits & Reported Receiving Benefits Last Wave

| | | |
|--|---|---|
| Receiving Benefits (P52=2) | | 5. All Others |
| 1. Ineligible for Dep IWing (P45A<>1 plan; or NEWPRELOAD.PP52<>2; or NEWPRELOAD.PP52=2 & (NEWPRELOAD.PPLANS>1 or NEWPRELOAD.PP53Yr=DK, RF)) | 2. Eligible for Dep IWing (P45A=1 plan & NEWPRELOAD.PP52=2 & NEWPRELOAD.PPLANS=1 & NEWPRELOAD.PP53Yr=Response) | GO TO P56ACKPT |
| ↓ | | Assign P53YR=NEWPRELOAD.PP53YR; Then GO TO P54 |

*Dependent Interviewing for Reinterviews*Defined Benefit (P46=DB Only or Both)

P53YR. [CYAQRTH, CYNAMF CYNAML], Plan #[1 / 2] Through a Former Employer

In what year did [you / he / she] start to receive these benefits?

- ENTER the year below

1901 – [CYEAR]

Defined Benefit (P46=DB Only or Both)

P54. [CYAQRTH, CYNAMF CYNAML], Plan #[1 / 2] Through a Former Employer

How much are the benefits per month or year?

- IF benefits have not yet begun, PROBE: What will the benefits be once [you / he / she] begin[s] receiving them?
- ENTER dollar amount here, then SELECT unit of time on next screen (Month, Year)

\$ 1 – 9,999,997 DK/RF → GO TO P54B

↓

P54PER. The amount entered is: [P54] per ____

- SELECT the unit of time below

5. Month 6. Year 7. Other-specify (P54PERSPEC. Specify. (String 100))

GO TO P55

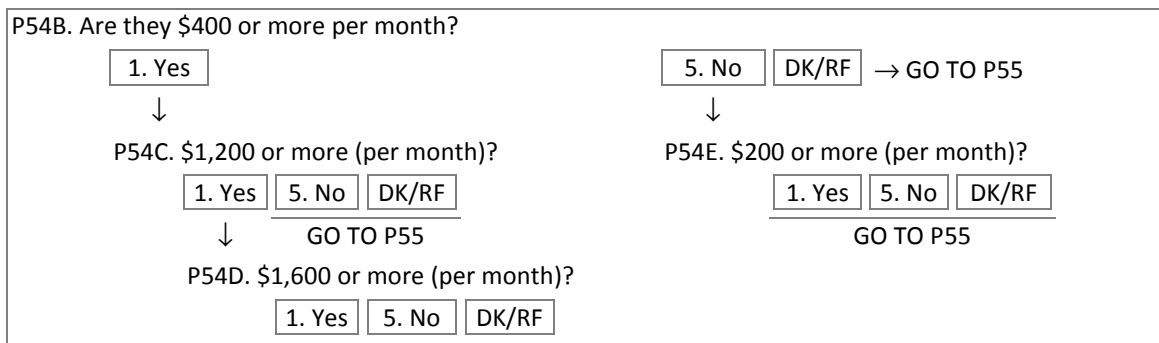

Defined Benefit (P46=DB Only or Both)

P55. [CYAQRTH, CYNAMF CYNAML], Plan #[1 / 2] Through a Former Employer

Are the benefits adjusted for changes in the cost of living?

1. Yes → GO TO P56ACKPT 5. No DK RF → GO TO P56ACKPT



P56. [CYAQRTH, CYNAMF CYNAML], Plan #[1 / 2] Through a Former Employer

Have they ever been adjusted for changes in the cost of living?

1. Yes 5. No

P56ACKPT. CAI Checkpoint: Whether Received Cash Settlement

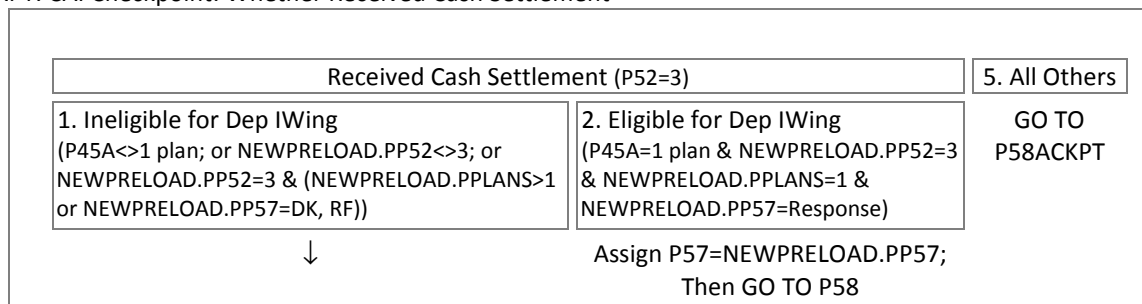

Dependent Interviewing for Reinterviews

Defined Benefit (P46=DB Only or Both)

P57. [CYAQRTH, CYNAMF CYNAML], Plan #[1 / 2] Through a Former Employer

How much did that cash settlement amount to?

\$ 1 – 9,999,997 → GO TO P58 DK/RF

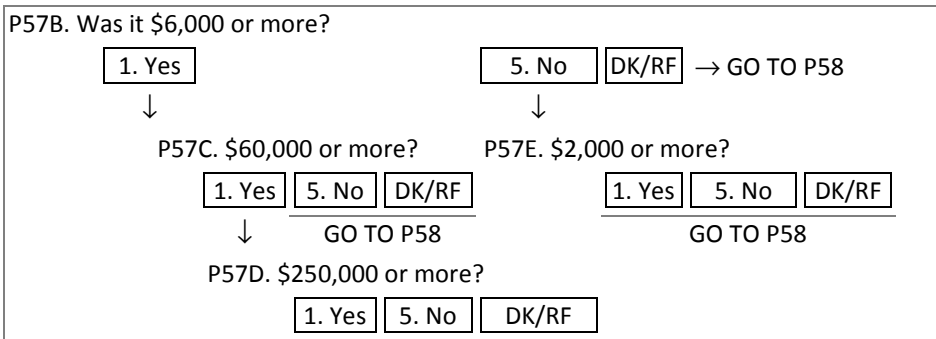

Defined Benefit (P46=DB Only or Both)

P58. [CYAQRTH, CYNAMF CYNAML], Plan #[1 / 2] Through a Former Employer

What did [you / he / she] do with the money?

- ENTER all that apply
- PROBE: Any others?

| | | | | |
|---|-------------|---------------------|------------------|-----------------------|
| 1. Bought durables | 2. Spent it | 3. Saved / invested | 4. Paid off debt | 5. Rolled into I.R.A. |
| 7. Other-specify (P58SPEC. Specify. (String 100)) | | | | |

P58ACKPT. CAI CHECKPOINT: Whether Rolled Into IRA

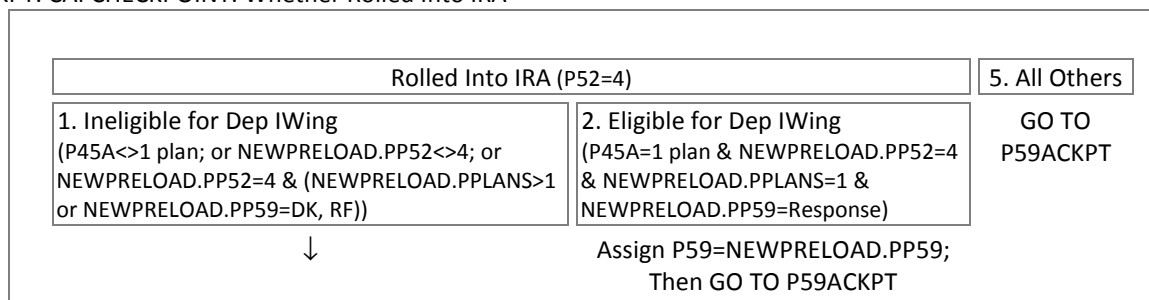

Dependent Interviewing for Reinterviews

Defined Benefit (P46=DB Only or Both)

P59. [CYAQRTH, CYNAMF CYNAML], Plan #[1 / 2] Through a Former Employer

How much did that I.R.A. (Individual Retirement Account) rollover amount to?

| | | |
|------------------|------------------|-------|
| \$ 1 – 9,999,997 | → GO TO P59ACKPT | DK/RF |
|------------------|------------------|-------|

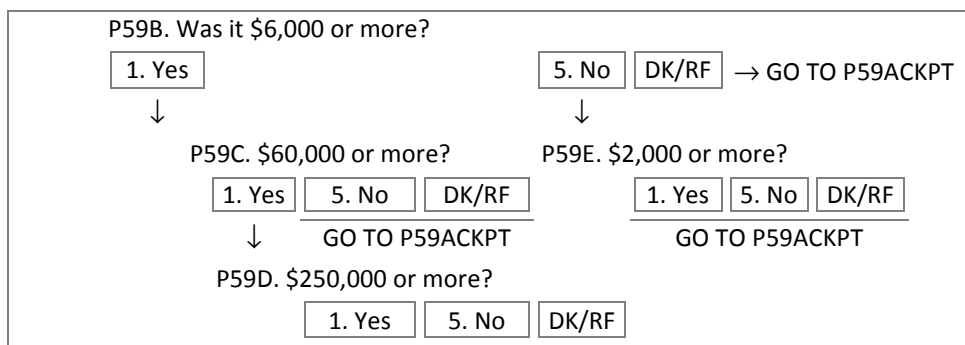

P59ACKPT. CAI Checkpoint: Whether Expects Benefits

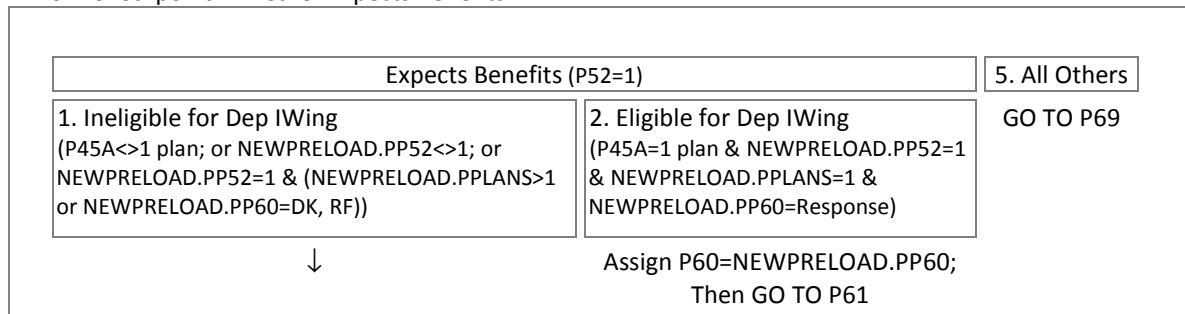

Dependent Interviewing for ReinterviewsDefined Benefit (P46=DB Only or Both)

P60. [CYAQRTH, CYNAMF CYNAML], Plan #[1 / 2] Through a Former Employer

For how many years altogether [were you / was [he / she]] included in this plan?

- INCLUDE years with other employers if same plan.

Defined Benefit (P46=DB Only or Both)

P61. [CYAQRTH, CYNAMF CYNAML], Plan #[1 / 2] Through a Former Employer

At what age [do you / does [he / she]] expect to start receiving (the rest of [your / his / her]) benefits from this plan?

- ENTER [97] if already receiving all benefits

→ GO TO P62ACKPT



P62AMT. [CYAQRTH, CYNAMF CYNAML], Plan #[1 / 2] Through a Former Employer

How much [do you / does [he / she]] expect to receive (, either as a percent of [your / his / her] pay when [you / he / she] left that job or as an amount per month or year)?

- ENTER dollar amount here, then SELECT unit of time on next screen (Month, Year)
- OR press [ENTER] to continue to next screen for Percent

→ GO TO P62PCT → GO TO P62F



P62PER. The amount entered is: [P62AMT] per ____

- SELECT the unit of time below

GO TO P62ACKPT

Defined Benefit (P46=DB Only or Both)

P62PCT. [CYAQRTH, CYNAMF CYNAML], Plan #[1 / 2] Through a Former Employer

(How much [do you / does [he / she]] expect to receive (, as a percent of [your / his / her] pay when [you / he / she] left that job)?)

- ENTER a percentage from 1.0 to 100.0

→ GO TO P62KCKPT



P62F. Will it be 40% of [your / his / her] pay or more?



→ GO TO P62KCKPT



P62G. 60% or more (of [your / his / her] pay)?



GO TO P62KCKPT

P62J. 20% or more (of [your / his / her] pay)?

GO TO P62KCKPT

P62H. 80% or more (of [your / his / her] pay)?

P62KCKPT. CAI Checkpoint: Whether P62PCT or P62F-P62J is Response



GO TO P62ACKPT

Defined Benefit (P46=DB Only or Both)

P62K. [CYAQRTH, CYNAMF CYNAML], Plan #[1 / 2] Through a Former Employer

And what was [your / his / her] pay when [you / he / she] left that job?

| | | |
|---------------------|-------|------------------|
| \$ 1 – 9,999,997.99 | DK/RF | → GO TO P62ACKPT |
|---------------------|-------|------------------|



P62KPER. The amount entered is: [P62K] per ____

- SELECT the unit of time below

| | | | | | |
|---------|--------|---------|--------------|----------|---------|
| 1. Hour | 2. Day | 3. Week | 4. Two Weeks | 5. Month | 6. Year |
|---------|--------|---------|--------------|----------|---------|

| |
|---|
| 7. Other-specify (P62KPERSPEC. Specify. (String 100)) |
|---|

P62ACKPT. CAI Checkpoint: Whether Pension Is DB Only or DC Only

| | | |
|--------------------|--------------------|--------------------------------|
| 1. DB Only (P46=1) | 3. DC Only (P46=5) | 5. All Others (P46=7 or DK/RF) |
| GO TO P69 | ↓ | GO TO P69 |

Defined Contribution (P46=DC Only)

P63. [CYAQRTH, CYNAMF CYNAML], Plan #[1 / 2] Through a Former Employer

How much money was in [your / his / her] account when [you / he / she] left that employer?

| | | |
|------------------|-------------|-------|
| \$ 1 – 9,999,997 | → GO TO P64 | DK/RF |
|------------------|-------------|-------|



| | | |
|--------------------------------|------------------------|-------------------|
| P63B. Was it \$20,000 or more? | | |
| 1. Yes | 5. No | DK/RF → GO TO P64 |
| ↓ | ↓ | |
| P63C. \$50,000 or more? | P63E. \$5,000 or more? | |
| 1. Yes | 5. No | DK/RF |
| ↓ | ↓ | |
| GO TO P64 | GO TO P64 | |
| P63D. \$150,000 or more? | | |
| 1. Yes | 5. No | DK/RF |

Defined Contribution (P46=DC Only)

P64. [CYAQRTH, CYNAMF CYNAML], Plan #[1 / 2] Through a Former Employer

When [you / he / she] left that employer, did [you / he / she] transfer [your / his / her] account to a new employer, roll it over into an I.R.A. (Individual Retirement Account), leave it to accumulate in [your / his / her] old plan, convert it to an annuity or what?

- If more than one response given, ENTER [7] and record all details

| | | | | | |
|--------------------------------|----------------------------|-----------------------|-------------------------|---|-------|
| 1. Transferred to new employer | 2. Rolled over into I.R.A. | 3. Left to accumulate | 4. Converted to annuity | 7. Other-specify (P64SPEC. Specify. (String 100)) | DK/RF |
| GO TO P69 | ↓ | GO TO P66 | GO TO P69 | | |

P65. [CYAQRTH, CYNAMF CYNAML], Plan #[1 / 2] Through a Former Employer

How much is in [your / his / her] account now?

 → GO TO P69

P65B. Is it \$50,000 or more?

→ GO TO P69



P65C. \$100,000 or more?

P65E. \$20,000 or more?



GO TO P69

GO TO P69

P65D. \$200,000 or more?

GO TO P69

Defined Contribution (P46=DC Only)

P66. [CYAQRTH, CYNAMF CYNAML], Plan #[1 / 2] Through a Former Employer

How old [were you / was [he / she]] when [you / he / she] started receiving the benefits from that annuity?

- IF benefits have not yet begun, PROBE: At what age will [you / he / she] begin receiving them?

Defined Contribution (P46=DC Only)

P67. [CYAQRTH, CYNAMF CYNAML], Plan #[1 / 2] Through a Former Employer

How much are the annuity benefits per month or year?

- IF benefits have not yet begun, PROBE: What will the benefits be once [you / he / she] begin[s] receiving them?
- ENTER dollar amount here, then SELECT unit of time on next screen (Month, Year)

→ GO TO P67B



P67PER. The amount entered is: [P67] per ____

- SELECT the unit of time below

GO TO GO TO P69

P67B. Are they \$400 or more per month?

→ GO TO P69



P67C. \$1,200 or more (per month)?

P67E. \$200 or more (per month)?



GO TO P69

GO TO P69

P67D. \$1,600 or more (per month)?

P69. [CYAQRTH, CYNAMF CYNAML]

[Do you / Does [HEAD / SP]] have any other pensions or retirement plans from a former employer (that you haven't already told me about)?

1. Yes → Repeat P46-P68; MAX=2; Then GO TO P70CKPT 5. No



SIGNAL FOR P69=NO, DK/RF and P45A=2-5:

Earlier R reported more than one pension plan from a previous employer. Please verify.

- If R verifies more than one pension plan from a previous employer, select CLOSE and ENTER [1] at this question
- If R verifies just one pension plan from a previous employer, select SUPPRESS to continue

END P45_P69

END SECTION_PDETAIL

P70CKPT. CAI Checkpoint: Whether Spouse/Partner in FU

1. Spouse/Partner (CYFUHU=FU, FUMI & CYAQRTH=201-222) 5. No Spouse/Partner → GO TO SECTION H



P70ACKPT. CAI Checkpoint: Employment Status of Spouse/Partner

1. Working Now
(BCDE1=1, 2 or BCDE3=Yes)

Repeat SECTION P; Then
GO TO SECTION H

2. Never Worked
(BC62=No, DK/RF)



Not Working Now (BCDE3=No, DK/RF)

Has Worked (BCDE3A=Yes or BC62=Yes)

3. Retired, Disabled, Keeping House,
Student, Other (BCDE1=4-8)

GO TO P45

5. Unemployed, DK/RF
(BCDE1=3, DK/RF)

GO TO P40AGE

END SECTION_P

Section H: Health

[TOC](#)

SECTION_H

SECTION_H.H1_H23[1-2] [1]=Current Head, [2]=Current Spouse/Partner

AQSN. AQSN of Current Head (Spouse/Partner)

H1. [CYNAMF CYNAML]: [CYAQRTH], [CYFUHU], Age [AGEIWDAT]E

Now I have a few questions about [your / [HEAD / SP]'s] health.

Would you say [your / [HEAD / SP]'s] health in general is excellent, very good, good, fair, or poor?

 1. Excellent
 2. Very good
 3. Good
 4. Fair
 5. Poor

H1A. [CYNAMF CYNAML]: [CYAQRTH], [CYFUHU], Age [AGEIWDAT]E

[RETURNING HEAD/SP: Since we last talked to you about [your / his / her] health, / NEW HEAD/SP, IMMIG16:

Compared to [your / his / her] health say, two years ago,) would you say that [your / his / her] health is better now, about the same, or worse?

 1. Better
 3. About the same → GO TO H2

 5. Worse
 DK/RF → GO TO H2

H1B. [CYNAMF CYNAML]: [CYAQRTH], [CYFUHU], Age [AGEIWDAT]E

Is it much better or somewhat better?

 1. Much better
 2. Somewhat better

H1C. [CYNAMF CYNAML]: [CYAQRTH], [CYFUHU], Age [AGEIWDAT]E

Is it much worse or somewhat worse?

 1. Much worse
 2. Somewhat worse

H2. [CYNAMF CYNAML]: [CYAQRTH], [CYFUHU], Age [AGEIWDAT]E

[Do you / Does [HEAD / SP]] have any physical or nervous condition that limits the type of work or the amount of work [you / he / she] can do?

 1. Yes
 5. No → GO TO H5A

H3. [CYNAMF CYNAML]: [CYAQRTH], [CYFUHU], Age [AGEIWDAT]E

Does this condition keep [you / [HEAD / SP]] from doing some types of work?
 1. Yes
 5. No
 7. Can do nothing (IF VOL) → GO TO H5A
 DK/RF

H4. [CYNAMF CYNAML]: [CYAQRTH], [CYFUHU], Age [AGEIWDAT]E

For work [you / [HEAD / SP]] can do, how much does it limit the amount of work [you / [HEAD / SP]] can do - a lot, somewhat, or just a little?
 1. A lot
 3. Somewhat
 5. Just a little
 7. Not at all

H5A. [CYNAMF CYNAML]: [CYAQRTH], [CYFUHU], Age [AGEIWDAT]E

These next questions ask you about health conditions that a doctor or other health professional has EVER told [you / [HEAD / SP]] that [you have / [he / she] has] or had in [your / his / her] lifetime.Has a doctor or other health professional EVER told [you / [HEAD / SP]] that [you / he / she] had...

A stroke?

 1. Yes
 5. No → GO TO H5B

H6A1. [CYNAMF CYNAML]: [CYAQRTH], [CYFUHU], Age [AGEIWDATE]

How old [were you / was [HEAD / SP]] the first time [you / he / she] had a stroke?

- ENTER [995] for less than 1 year

H6A2. [CYNAMF CYNAML]: [CYAQRTH], [CYFUHU], Age [AGEIWDATE]

[Have you / Has [he / she]] had [RETURNING H/SP & AGE minus H6A1 > (REINT, SO: 2 YRS; RECON, RECSO: 4 YRS): another stroke since our last interview in [REINT, SO: [P2YEAR] / RECON, RECSO: [P4YEAR]] [PYIWDATE=RESPONSE: ([PYIWDATE])] / ALL OTHERS (IMMIG16): a second or subsequent stroke since that first one]?

H7A. [CYNAMF CYNAML]: [CYAQRTH], [CYFUHU], Age [AGEIWDATE]

How much does this condition limit [your / his / her] normal daily activities? A lot, somewhat, just a little, or not at all?

H7A2. [CYNAMF CYNAML]: [CYAQRTH], [CYFUHU], Age [AGEIWDATE]

[Are you / Is [HEAD / SP]] now taking medication because of [your / his / her] stroke or its complications?

H5B. [CYNAMF CYNAML]: [CYAQRTH], [CYFUHU], Age [AGEIWDATE]

(Has a doctor or other health professional **EVER** told [you / [HEAD / SP]] that [you / he / she] had...)
A heart attack?

→ GO TO H5C

↓

H6B1. [CYNAMF CYNAML]: [CYAQRTH], [CYFUHU], Age [AGEIWDATE]

How old [were you / was [HEAD / SP]] the first time [you / he / she] had a heart attack?

- ENTER [995] for less than 1 year

H6B2. [CYNAMF CYNAML]: [CYAQRTH], [CYFUHU], Age [AGEIWDATE]

[Have you / Has [he / she]] had [RETURNING H/SP & AGE minus H6B1 > (REINT, SO: 2 YS; RECON, RECSO: 4 YS): another heart attack since our last interview in [REINT, SO: [P2YEAR] / RECON, RECSO: [P4YEAR]] [PYIWDATE=RESPONSE: ([PYIWDATE])] / ALL OTHERS (IMMIG16): a second or subsequent heart attack since that first one]?

H7B. [CYNAMF CYNAML]: [CYAQRTH], [CYFUHU], Age [AGEIWDATE]

How much does this condition limit [your / his / her] normal daily activities? A lot, somewhat, just a little, or not at all?

H7B2. [CYNAMF CYNAML]: [CYAQRTH], [CYFUHU], Age [AGEIWDATE]

[Are you / Is [HEAD / SP]] now taking or carrying medication because of [your / his / her] heart attack?

H5C. [CYNAMF CYNAML]: [CYAQRTH], [CYFUHU], Age [AGEIWDATE]

(Has a doctor or other health professional **EVER** told [you / [HEAD / SP]] that [you / he / she] had ...)
Coronary heart disease, angina, or congestive heart failure?

1. Yes 5. No → GO TO H5D



H6C1. [CYNAMF CYNAML]: [CYAQRTH], [CYFUHU], Age [AGEIWDATE]

How old [were you / was [HEAD / SP]] when [you were / [he / she] was] first diagnosed with (this condition / any of these conditions)?

- ENTER [995] for less than 1 year

1 – [CURRENT AGE] 995. Less than one year old (IF VOL)

H7C. [CYNAMF CYNAML]: [CYAQRTH], [CYFUHU], Age [AGEIWDATE]

How much does this condition limit [your / his / her] normal daily activities? A lot, somewhat, just a little, or not at all?

1. A lot 3. Somewhat 5. Just a little 7. Not at all

H7C2. [CYNAMF CYNAML]: [CYAQRTH], [CYFUHU], Age [AGEIWDATE]

[Are you / Is [HEAD / SP]] now taking or carrying medication for [your / his / her] coronary heart disease, angina or congestive heart failure?

1. Yes 5. No

H5D. [CYNAMF CYNAML]: [CYAQRTH], [CYFUHU], Age [AGEIWDATE]

(Has a doctor or other health professional **EVER** told [you / [HEAD / SP]] that [you / he / she] had ...)
High blood pressure or hypertension?

1. Yes 5. No → GO TO H5E



H6D1. [CYNAMF CYNAML]: [CYAQRTH], [CYFUHU], Age [AGEIWDATE]

How old [were you / was [HEAD / SP]] when [you were / [he / she] was] first diagnosed with high blood pressure or hypertension?

- ENTER [995] for less than 1 year

1 – [CURRENT AGE] 995. Less than one year old (IF VOL)

H7D. [CYNAMF CYNAML]: [CYAQRTH], [CYFUHU], Age [AGEIWDATE]

How much does this condition limit [your / his / her] normal daily activities? A lot, somewhat, just a little, or not at all?

1. A lot 3. Somewhat 5. Just a little 7. Not at all

H7D2. [CYNAMF CYNAML]: [CYAQRTH], [CYFUHU], Age [AGEIWDATE]

[Are you / Is [HEAD / SP]] now taking medication to lower [your / his / her] blood pressure?

1. Yes 5. No

H5E. [CYNAMF CYNAML]: [CYAQRTH], [CYFUHU], Age [AGEIWDATE]

(Has a doctor or other health professional EVER told [you / [HEAD / SP]] that [you / he / she] had ...)
Asthma?

1. Yes 5. No → GO TO H5F



H6E1. How old [were you / was [HEAD / SP]] when [you were / [he / she] was] first diagnosed with asthma?

- ENTER [995] for less than 1 year

1 – [CURRENT AGE] 995. Less than one year old (IF VOL)

H7E. [CYNAMF CYNAML]: [CYAQRTH], [CYFUHU], Age [AGEIWDATE]

How much does this condition limit [your / his / her] normal daily activities? A lot, somewhat, just a little, or not at all?

1. A lot 3. Somewhat 5. Just a little 7. Not at all

H7E2. [CYNAMF CYNAML]: [CYAQRTH], [CYFUHU], Age [AGEIWDATE]

In order to treat or control [your / his / her] asthma, [are you / is [HEAD / SP]] now taking or carrying medication or an inhaler?

1. Yes 5. No

H5F. [CYNAMF CYNAML]: [CYAQRTH], [CYFUHU], Age [AGEIWDATE]

(Has a doctor or other health professional EVER told [you / [HEAD / SP]] that [you / he / she] had ...)
Chronic lung disease such as bronchitis or emphysema?

1. Yes 5. No → GO TO H5G



H6F1. [CYNAMF CYNAML]: [CYAQRTH], [CYFUHU], Age [AGEIWDATE]

How old [were you / was [HEAD / SP]] when [you were / [he / she] was] first diagnosed with (lung disease / bronchitis / emphysema)?

- ENTER [995] for less than 1 year

1 – [CURRENT AGE] 995. Less than one year old (IF VOL)

H7F. [CYNAMF CYNAML]: [CYAQRTH], [CYFUHU], Age [AGEIWDATE]

How much does this condition limit [your / his / her] normal daily activities? A lot, somewhat, just a little, or not at all?

1. A lot 3. Somewhat 5. Just a little 7. Not at all

H7F2. [CYNAMF CYNAML]: [CYAQRTH], [CYFUHU], Age [AGEIWDATE]

[Are you / Is [HEAD / SP]] now taking medication or receiving oxygen or other treatment for [your / his / her] lung condition?

1. Yes 5. No

H5G. [CYNAMF CYNAML]: [CYAQRTH], [CYFUHU], Age [AGEIWDATE]

(Has a doctor or other health professional EVER told [you / [HEAD / SP]] that [you / he / she] had ...)
Diabetes or high blood sugar?

1. Yes 5. No → GO TO H5H



H6G1. [CYNAMF CYNAML]: [CYAQRTH], [CYFUHU], Age [AGEIWDATE]

How old [were you / was [HEAD / SP]] when [you were / [he / she] was] first diagnosed with diabetes?

- ENTER [995] for less than 1 year

1 – [CURRENT AGE] 995. Less than one year old (IF VOL)

H7G. [CYNAMF CYNAML]: [CYAQRTH], [CYFUHU], Age [AGEIWDATE]

How much does this condition limit [your / his / her] normal daily activities? A lot, somewhat, just a little, or not at all?

1. A lot 3. Somewhat 5. Just a little 7. Not at all

H7G2. [CYNAMF CYNAML]: [CYAQRTH], [CYFUHU], Age [AGEIWDATE]

In order to treat or control [your / his / her] diabetes, [are you / is [HEAD / SP]] now taking medication that [you / he / she] swallow[s] or using insulin shots or a pump?

1. Yes 5. No

H5H. [CYNAMF CYNAML]: [CYAQRTH], [CYFUHU], Age [AGEIWDATE]

(Has a doctor or other health professional EVER told [you / [HEAD / SP]] that [you / he / she] had ...)
Arthritis or rheumatism?

1. Yes 5. No → GO TO H5I



H6H1. [CYNAMF CYNAML]: [CYAQRTH], [CYFUHU], Age [AGEIWDATE]

How old [were you / was [HEAD / SP]] when [you were / [he / she] was] first diagnosed with (arthritis / rheumatism)?

- ENTER [995] for less than 1 year

1 – [CURRENT AGE] 995. Less than one year old (IF VOL)

H7H. [CYNAMF CYNAML]: [CYAQRTH], [CYFUHU], Age [AGEIWDATE]

How much does this condition limit [your / his / her] normal daily activities? A lot, somewhat, just a little, or not at all?

1. A lot 3. Somewhat 5. Just a little 7. Not at all

H7H2. [CYNAMF CYNAML]: [CYAQRTH], [CYFUHU], Age [AGEIWDATE]

[Are you / Is [HEAD / SP]] now taking medication or receiving treatment for [your / his / her] arthritis or rheumatism?

1. Yes 5. No

H5I. [CYNAMF CYNAML]: [CYAQRTH], [CYFUHU], Age [AGEIWDATE]

(Has a doctor or other health professional EVER told [you / [HEAD / SP]] that [you / he / she] had ...)
Permanent loss of memory or loss of mental ability?

1. Yes 5. No → GO TO H5J



H6I1. [CYNAMF CYNAML]: [CYAQRTH], [CYFUHU], Age [AGEIWDATE]

How old [were you / was [HEAD / SP]] when [you were / [he / she] was] first diagnosed with (loss of memory / mental ability)?

- ENTER [995] for less than 1 year

1 – [CURRENT AGE] 995. Less than one year old (IF VOL)

H7I. [CYNAMF CYNAML]: [CYAQRTH], [CYFUHU], Age [AGEIWDATE]

How much does this condition limit [your / his / her] normal daily activities? A lot, somewhat, just a little, or not at all?

1. A lot 3. Somewhat 5. Just a little 7. Not at all

H7I2. [CYNAMF CYNAML]: [CYAQRTH], [CYFUHU], Age [AGEIWDATE]

[Are you / Is [HEAD / SP]] now taking medication prescribed by a doctor to help with [your / his / her] memory problem?

1. Yes 5. No

H5J. [CYNAMF CYNAML]: [CYAQRTH], [CYFUHU], Age [AGEIWDATE]

(Has a doctor or other health professional EVER told [you / [HEAD / SP]] that [you / he / she] had...)
A learning disorder?

1. Yes 5. No → GO TO H5K



H6J1. [CYNAMF CYNAML]: [CYAQRTH], [CYFUHU], Age [AGEIWDATE]

How old [were you / was [HEAD / SP]] when [you were / [he / she] was] first diagnosed with a learning disorder?

- ENTER [995] for less than 1 year

1 – [CURRENT AGE] 995. Less than one year old (IF VOL)

H7J. [CYNAMF CYNAML]: [CYAQRTH], [CYFUHU], Age [AGEIWDATE]

How much does this condition limit [your / his / her] normal daily activities? A lot, somewhat, just a little, or not at all?

1. A lot 3. Somewhat 5. Just a little 7. Not at all

H7J2. [CYNAMF CYNAML]: [CYAQRTH], [CYFUHU], Age [AGEIWDATE]

[Are you / Is [HEAD / SP]] now receiving treatment or taking medication to help with [your / his / her] learning disorder?

1. Yes 5. No

H5K. [CYNAMF CYNAML]: [CYAQRTH], [CYFUHU], Age [AGEIWDATE]

(Has a doctor or other health professional EVER told [you / [HEAD / SP]] that [you / he / she] had ...)
Cancer or a malignant tumor?

1. Yes 5. No → GO TO H5L



H6K1. [CYNAMF CYNAML]: [CYAQRTH], [CYFUHU], Age [AGEIWDATE]

How old [were you / was [HEAD / SP]] when [you were / [he / she] was] first diagnosed with cancer?

- ENTER [995] for less than 1 year

1 – [CURRENT AGE] 995. Less than one year old (IF VOL)

H6K3. [CYNAMF CYNAML]: [CYAQRTH], [CYFUHU], Age [AGEIWDATE]

[Are you / Is [HEAD / SP]] currently in treatment for [your / his / her] cancer, in remission, or has it been cured?

- If R says can't afford insurance to get treatment, are doing nothing, etc, ENTER: [4]

1. Treatment 2. Remission 3. Cured 4. Not getting treatment (IF VOL)

H6K4. [CYNAMF CYNAML]: [CYAQRTH], [CYFUHU], Age [AGEIWDATE]

What type of cancer [do you / does [he / she]] have? (In what part of [your / his / her] body is it?)

- ENTER all that apply
- PROBE: Any others?

| | | |
|---|---------------------------------|--|
| 1. Bladder cancer | 2. Breast cancer | 3. Cervical cancer |
| 4. Colon cancer | 5. Lung cancer | 6. Lymphoma or leukemia |
| 7. Ovarian cancer | 8. Prostate cancer | 9. Skin cancer, Melanoma |
| 10. Skin cancer, non-melanoma (e.g. basal cell) | 11. Skin cancer, <u>DK type</u> | |
| 12. Thyroid cancer | 13. Uterine cancer | 97. Other-specify (H6K4SPEC. Specify (String 100)) |

H7K. [CYNAMF CYNAML]: [CYAQRTH], [CYFUHU], Age [AGEIWDATE]

How much does this condition limit [your / his / her] normal daily activities? A lot, somewhat, just a little, or not at all?

1. A lot 3. Somewhat 5. Just a little 7. Not at all

H5L. [CYNAMF CYNAML]: [CYAQRTH], [CYFUHU], Age [AGEIWDATE]

(Has a doctor or other health professional EVER told [you / [HEAD / SP]] that [you / he / she] had ...)
Any emotional, nervous, or psychiatric problems?

1. Yes 5. No → GO TO H5M



H6L1. [CYNAMF CYNAML]: [CYAQRTH], [CYFUHU], Age [AGEIWDATE]

How old [were you / was [HEAD / SP]] when [you were / [he / she] was] first diagnosed?

- ENTER [995] for less than 1 year

1 – [CURRENT AGE] 995. Less than one year old (IF VOL)

H6L2. [CYNAMF CYNAML]: [CYAQRTH], [CYFUHU], Age [AGEIWDATE]

What was the diagnosis? What is the emotional / psychiatric disorder?

- ENTER all that apply
- PROBE: Any others?

| | | |
|--|--|-------------------------------------|
| 1. Depression | 2. Bipolar disorder (mania) | 3. Schizophrenia (psychosis) |
| 4. Anxiety (panic) | 5. Phobias | 6. Alcohol use / abuse (alcoholism) |
| 7. Drug use / abuse (drug addiction) | 8. Obsessive compulsive | |
| 9. PTSD (Post-Traumatic Stress Disorder) | 97. Other-specify (H6L2SPEC. Specify (String 100)) | |

H7L. [CYNAMF CYNAML]: [CYAQRTH], [CYFUHU], Age [AGEIWDATE]

How much does this condition limit [your / his / her] normal daily activities? A lot, somewhat, just a little, or not at all?

| | | | |
|----------|-------------|------------------|---------------|
| 1. A lot | 3. Somewhat | 5. Just a little | 7. Not at all |
|----------|-------------|------------------|---------------|

H7L2. [CYNAMF CYNAML]: [CYAQRTH], [CYFUHU], Age [AGEIWDATE]

[Are you / Is [HEAD / SP]] taking tranquilizers, antidepressants, or pills for nerves?

| | |
|--------|-------|
| 1. Yes | 5. No |
|--------|-------|

H5M. [CYNAMF CYNAML]: [CYAQRTH], [CYFUHU], Age [AGEIWDATE]

Is there any other serious, chronic condition that a doctor or other health professional EVER told [you / [HEAD / SP]] that [you / he / she] had?

| | | |
|--------|-------|-----------------|
| 1. Yes | 5. No | → GO TO H5NCKPT |
|--------|-------|-----------------|

↓

H6M1. [CYNAMF CYNAML]: [CYAQRTH], [CYFUHU], Age [AGEIWDATE]

What is that condition?

| |
|------------|
| String 500 |
|------------|

H6M2. [CYNAMF CYNAML]: [CYAQRTH], [CYFUHU], Age [AGEIWDATE]

How old [were you / was [HEAD / SP]] when [you were / [he / she] was] first diagnosed?

- ENTER [995] for less than 1 year

| | |
|-------------------|--------------------------------------|
| 1 – [CURRENT AGE] | 995. Less than one year old (IF VOL) |
|-------------------|--------------------------------------|

H7M. [CYNAMF CYNAML]: [CYAQRTH], [CYFUHU], Age [AGEIWDATE]

How much does this condition limit [your / his / her] normal daily activities? A lot, somewhat, just a little, or not at all?

| | | | |
|----------|-------------|------------------|---------------|
| 1. A lot | 3. Somewhat | 5. Just a little | 7. Not at all |
|----------|-------------|------------------|---------------|

H7M2. [CYNAMF CYNAML]: [CYAQRTH], [CYFUHU], Age [AGEIWDATE]

[Are you / Is [HEAD / SP]] now taking medication for this condition?

| | |
|--------|-------|
| 1. Yes | 5. No |
|--------|-------|

Dementia Screener

H5N2-H5N9: All rights reserved. Copyright 2008 by Washington University in St. Louis, Missouri.

H5NCKPT. CAI Checkpoint: Whether Head (Spouse/Partner) is 65 Years Old or Older

| | | |
|------------------------------------|---|------------|
| 1. Age 65 or Older (AGEIWDATE=65+) | 5. Age Less Than 65 (AGEIWDATE<65 or DK/RF) | → GO TO H8 |
| ↓ | | |

H5N2. [CYNAMF CYNAML]: [CYAQRTH], [CYFUHU], Age [AGEIWDATE]

Next, we'd like to know about changes that [you / [HEAD / SP]] may have had in the last several years [*THIS PERSON IS NOT R: because of a thinking or memory problem*].

In the last several years, has there been a change in problems [you / he / she] may have with judgment, for example, problems making decisions, making bad financial decisions, or with thinking?

1. Yes, a change 5. No, no change

H5N3. [CYNAMF CYNAML]: [CYAQRTH], [CYFUHU], Age [AGEIWDATE]

In the last several years, has there been a change in...

The amount of interest [you / he / she] may have in hobbies or activities?

1. Yes, a change 5. No, no change

H5N4. [CYNAMF CYNAML]: [CYAQRTH], [CYFUHU], Age [AGEIWDATE]

(In the last several years, has there been a change in...)

[Your / His / Her] repeating the same things over and over, such as questions, stories, or statements?

1. Yes, a change 5. No, no change

H5N5. [CYNAMF CYNAML]: [CYAQRTH], [CYFUHU], Age [AGEIWDATE]

(In the last several years, has there been a change in ...)

The trouble [you / he / she] may have learning how to use a tool, appliance or gadget like a TV remote?

1. Yes, a change 5. No, no change

H5N6. [CYNAMF CYNAML]: [CYAQRTH], [CYFUHU], Age [AGEIWDATE]

(In the last several years, has there been a change in ...)

[Your / His / Her] forgetting the correct month or year?

1. Yes, a change 5. No, no change

H5N7. [CYNAMF CYNAML]: [CYAQRTH], [CYFUHU], Age [AGEIWDATE]

(In the last several years, has there been a change in...)

The trouble [you / he / she] may have handling complicated money matters, like balancing a checkbook or paying bills?

1. Yes, a change 5. No, no change

H5N8. [CYNAMF CYNAML]: [CYAQRTH], [CYFUHU], Age [AGEIWDATE]

(In the last several years, has there been a change in...)

The trouble [you / he / she] may have remembering appointments?

1. Yes, a change 5. No, no change

H5N9. [CYNAMF CYNAML]: [CYAQRTH], [CYFUHU], Age [AGEIWDATE]

(In the last several years, has there been a change in...)

Daily problems [you / he / she] may have with thinking and/or memory?

1. Yes, a change 5. No, no change

H8. [CYNAMF CYNAML]: [CYAQRTH], [CYFUHU], Age [AGEIWDAT]E

[Were you / Was [HEAD / SP]] a patient in a hospital overnight or longer at any time during [PYEAR]?

1. Yes 5. No → GO TO H8A3



H8A. [CYNAMF CYNAML]: [CYAQRTH], [CYFUHU], Age [AGEIWDAT]E

How many nights [were you / was [HEAD / SP]] in a hospital altogether in [PYEAR]?

- ENTER amount here, then SELECT unit of time on next screen (Nights, Weeks)

0 – 365 DK/RF → GO TO H8A3



H8A2. [CYNAMF CYNAML]: [CYAQRTH], [CYFUHU], Age [AGEIWDAT]E

The amount entered is: [H8A]

- SELECT the unit of time below

1. Nights 2. Weeks

H8A3. (H5 1986) [CYNAMF CYNAML]: [CYAQRTH], [CYFUHU], Age [AGEIWDAT]E

[Do you / Does [he / she]] have any trouble either walking several blocks or climbing a few flights of stairs, because of [your / his / her] health?

1. Yes 5. No

H8A4. (H6 1986) [CYNAMF CYNAML]: [CYAQRTH], [CYFUHU], Age [AGEIWDAT]E

[Do you / Does [he / she]] have trouble bending, lifting, or stooping because of [your / his / her] health?

1. Yes 5. No

H9A. [CYNAMF CYNAML]: [CYAQRTH], [CYFUHU], Age [AGEIWDAT]E

The next questions are about [your / [HEAD / SP]'s] ability to do certain activities - by [yourself / himself / herself] and without special equipment.

Because of a health or physical problem, [do you / does [he / she]] have any difficulty bathing or showering?

1. Yes 5. No → GO TO H9B



H10A1. [CYNAMF CYNAML]: [CYAQRTH], [CYFUHU], Age [AGEIWDAT]E

Does someone usually help [you / him / her] with that activity?

1. Yes 5. No

H10A2. [CYNAMF CYNAML]: [CYAQRTH], [CYFUHU], Age [AGEIWDAT]E

[Do you / Does [he / she]] usually use special equipment to do that activity?

1. Yes 5. No

H9B. [CYNAMF CYNAML]: [CYAQRTH], [CYFUHU], Age [AGEIWDAT]E

(Because of a health or physical problem, [do you / does [he / she]] have any difficulty...) Dressing?

1. Yes 5. No → GO TO H9C



H10B1. [CYNAMF CYNAML]: [CYAQRTH], [CYFUHU], Age [AGEIWDAT]E

Does someone usually help [you / him / her] with that activity?

1. Yes 5. No

H10B2. [CYNAMF CYNAML]: [CYAQRTH], [CYFUHU], Age [AGEIWDAT]E

[Do you / Does [he / she]] usually use special equipment to do that activity?

1. Yes 5. No

H9C. [CYNAMF CYNAML]: [CYAQRTH], [CYFUHU], Age [AGEIWDATE]

(Because of a health or physical problem, [do you / does [he / she]] have any difficulty...)
Eating?

1. Yes 5. No → GO TO H9D



H10C1. [CYNAMF CYNAML]: [CYAQRTH], [CYFUHU], Age [AGEIWDATE]

Does someone usually help [you / him / her] with that activity?

1. Yes 5. No

H10C2. [CYNAMF CYNAML]: [CYAQRTH], [CYFUHU], Age [AGEIWDATE]

[Do you / Does [he / she]] usually use special equipment to do that activity?

1. Yes 5. No

H9D. [CYNAMF CYNAML]: [CYAQRTH], [CYFUHU], Age [AGEIWDATE]

(Because of a health or physical problem, [do you / does [he / she]] have any difficulty...)
Getting in or out of bed or a chair?

1. Yes 5. No → GO TO H9E



H10D1. [CYNAMF CYNAML]: [CYAQRTH], [CYFUHU], Age [AGEIWDATE]

Does someone usually help [you / him / her] with that activity?

1. Yes 5. No

H10D2. [CYNAMF CYNAML]: [CYAQRTH], [CYFUHU], Age [AGEIWDATE]

[Do you / Does [he / she]] usually use special equipment to do that activity?

1. Yes 5. No

H9E. [CYNAMF CYNAML]: [CYAQRTH], [CYFUHU], Age [AGEIWDATE]

Because of a health or physical problem, [do you / does [HEAD / SP]] have any difficulty...)
Walking?

1. Yes 5. No → GO TO H9F



H10E1. [CYNAMF CYNAML]: [CYAQRTH], [CYFUHU], Age [AGEIWDATE]

Does someone usually help [you / him / her] with that activity?

1. Yes 5. No

H10E2. [CYNAMF CYNAML]: [CYAQRTH], [CYFUHU], Age [AGEIWDATE]

[Do you / Does [he / she]] usually use special equipment to do that activity?

1. Yes 5. No

H9F. [CYNAMF CYNAML]: [CYAQRTH], [CYFUHU], Age [AGEIWDATE]

(Because of a health or physical problem, [do you / does [he / she]] have any difficulty...)
Getting outside?

1. Yes 5. No → GO TO H9G



H10F1. [CYNAMF CYNAML]: [CYAQRTH], [CYFUHU], Age [AGEIWDATE]

Does someone usually help [you / him / her] with that activity?

1. Yes 5. No

H10F2. [CYNAMF CYNAML]: [CYAQRTH], [CYFUHU], Age [AGEIWDATE]

[Do you / Does [he / she]] usually use special equipment to do that activity?

1. Yes 5. No

H9G. [CYNAMF CYNAML]: [CYAQRTH], [CYFUHU], Age [AGEIWDATE]

(Because of a health or physical problem, [do you / does [he / she]] have any difficulty...)
Using the toilet, including getting to the toilet?

1. Yes 5. No → GO TO H11A



H10G1. [CYNAMF CYNAML]: [CYAQRTH], [CYFUHU], Age [AGEIWDATE]

Does someone usually help [you / him / her] with that activity?

1. Yes 5. No

H10G2. [CYNAMF CYNAML]: [CYAQRTH], [CYFUHU], Age [AGEIWDATE]

[Do you / Does [he / she]] usually use special equipment to do that activity?

1. Yes 5. No

H11A. [CYNAMF CYNAML]: [CYAQRTH], [CYFUHU], Age [AGEIWDATE]

The next questions are about doing other activities by [yourself / himself / herself] and without special equipment.
Because of a health or physical problem, [do you / does [HEAD / SP]] have any difficulty preparing [your / his / her] own meals?

1. Yes 5. No DK/RF 7. Does not do → H11B. [CYNAMF CYNAML]: [CYAQRTH], [CYFUHU], Age [AGEIWDATE]

Is this because of a health or physical problem?

1. Yes 5. No



H11C. [CYNAMF CYNAML]: [CYAQRTH], [CYFUHU], Age [AGEIWDATE]

([Do you / Does [HEAD / SP]] have any difficulty...)

Shopping for personal items or medicines?

1. Yes 5. No DK/RF 7. Does not do → H11D. [CYNAMF CYNAML]: [CYAQRTH], [CYFUHU], Age [AGEIWDATE]

Is this because of a health or physical problem?

1. Yes 5. No



H11E. [CYNAMF CYNAML]: [CYAQRTH], [CYFUHU], Age [AGEIWDATE]

([Do you / Does [HEAD / SP]] have any difficulty...)

Managing [your / his / her] own money, such as keeping track of expenses or paying bills?

1. Yes 5. No DK/RF 7. Does not do → H11F. [CYNAMF CYNAML]: [CYAQRTH], [CYFUHU], Age [AGEIWDATE]

Is this because of a health or physical problem?

1. Yes 5. No



H11G. [CYNAMF CYNAML]: [CYAQRTH], [CYFUHU], Age [AGEIWDATE]

((Do you / Does [HEAD / SP]) have any difficulty...)

Using the telephone?

1. Yes 5. No DK/RF 7. Does not do →



H11H. [CYNAMF CYNAML]: [CYAQRTH], [CYFUHU], Age [AGEIWDATE]

Is this because of a health or physical problem?

1. Yes 5. No

H11J. [CYNAMF CYNAML]: [CYAQRTH], [CYFUHU], Age [AGEIWDATE]

((Do you / Does [HEAD / SP]) have any difficulty...)

Doing heavy housework, like scrubbing floors or washing windows?

1. Yes 5. No DK/RF 7. Does not do →



H11K. [CYNAMF CYNAML]: [CYAQRTH], [CYFUHU], Age [AGEIWDATE]

Is this because of a health or physical problem?

1. Yes 5. No

H11L. [CYNAMF CYNAML]: [CYAQRTH], [CYFUHU], Age [AGEIWDATE]

((Do you / Does [HEAD / SP]) have any difficulty...)

Doing light housework, like doing dishes, straightening up, or light housecleaning?

1. Yes 5. No DK/RF 7. Does not do →



H11M. [CYNAMF CYNAML]: [CYAQRTH], [CYFUHU], Age [AGEIWDATE]

Is this because of a health or physical problem?

1. Yes 5. No

H12A. [CYNAMF CYNAML]: [CYAQRTH], [CYFUHU], Age [AGEIWDATE]

The next questions are about physical activities (exercise, sports, physically active hobbies...) that [you / [HEAD / SP]] may do in [your / his / her] leisure time.

(In [your / [HEAD / SP]'s] leisure time,) how often [do you / does [HEAD / SP]] do VIGOROUS activities for at least 10 minutes that cause heavy sweating or large increases in breathing or heart rate?

- ENTER amount here, then SELECT unit of time on next screen (Week, Month, Year)
- If R says never, ENTER [0]
- If R says every day, ENTER [7] here and ENTER [WEEK] on the next screen
- If R reports hours or minutes per week/month/year, PROBE: We are looking for the number of times per week, month, or year

0 → GO TO H12B 1 – 100 DK/RF → GO TO H12B



H12APER. The amount entered is: [H12A] times per ____

- SELECT the unit of time below
- If R says every day, ENTER [7] on the previous screen and ENTER [WEEK] here

3. Week 5. Month 6. Year 7. Other-specify (H12APERSPEC. Specify. (String 100))

H12B. [CYNAMF CYNAML]: [CYAQRTH], [CYFUHU], Age [AGEIWDATE]

(In [your / [HEAD / SP]'s] leisure time,...)

(How often [do you / does [HEAD / SP]] do) light or moderate activities for at least 10 minutes that cause only light sweating or slight to moderate increases in breathing or heart rate?

- ENTER amount here, then SELECT unit of time on next screen (Week, Month, Year)
- If R says never, ENTER [0]
- If R says every day, ENTER [7] here and ENTER [WEEK] on the next screen
- If R reports hours or minutes per week/month/year, PROBE: We are looking for the number of times per week, month, or year

 → GO TO H12C → GO TO H12C

H12BPER. The amount entered is: [H12B] times per ____

- SELECT the unit of time below
- If R says every day, ENTER [7] on the previous screen and ENTER [WEEK] here

H12C. [CYNAMF CYNAML]: [CYAQRTH], [CYFUHU], Age [AGEIWDATE]

(In [your / [HEAD / SP]'s] leisure time,...)

(How often [do you / does [HEAD / SP]] do) physical activities specifically designed to strengthen [your / his / her] muscles such as lifting weights?

- ENTER amount here, then SELECT unit of time on next screen (Week, Month, Year)
- If R says never, ENTER [0]
- If R says every day, ENTER [7] here and ENTER [WEEK] on the next screen
- If R reports hours or minutes per week/month/year, PROBE: We are looking for the number of times per week, month, or year

 → GO TO H13 → GO TO H13

H12CPER. The amount entered is: [H12C] times per ____

- SELECT the unit of time below
- If R says every day, ENTER [7] on the previous screen and ENTER [WEEK] here

H13. [CYNAMF CYNAML]: [CYAQRTH], [CYFUHU], Age [AGEIWDATE]

[Do you / Does [HEAD / SP]] smoke cigarettes?

 → GO TO H16CKPT

H14. [CYNAMF CYNAML]: [CYAQRTH], [CYFUHU], Age [AGEIWDATE]

On average, how many cigarettes per day [do you / does [he / she]] usually smoke?

- DEFINITION: A standard pack of American cigarettes contains 20 cigarettes
- For one cigarette or less per day, ENTER [1]

H15CKPT. CAI Checkpoint: Whether Head (Spouse/Partner) Reported Current Smoking Last Wave

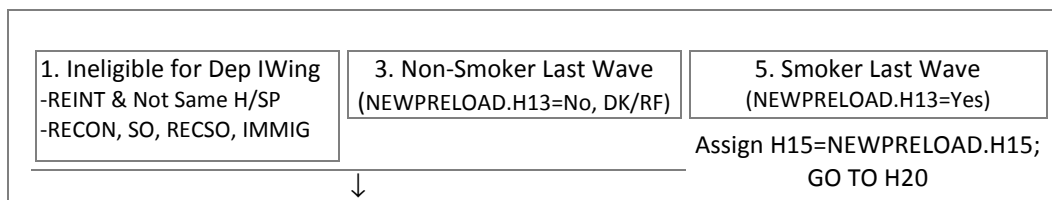

Dependent Interviewing for Reinterviews

H15. [CYNAMF CYNAML]: [CYAQRTH], [CYFUHU], Age [AGEIWDATE]

How old [were you / was [HEAD / SP]] when [you / he / she] first smoked cigarettes regularly?

GO TO H20

H16CKPT. CAI Checkpoint: Whether Head (Spouse/Partner) Reported Current Smoking Last Wave

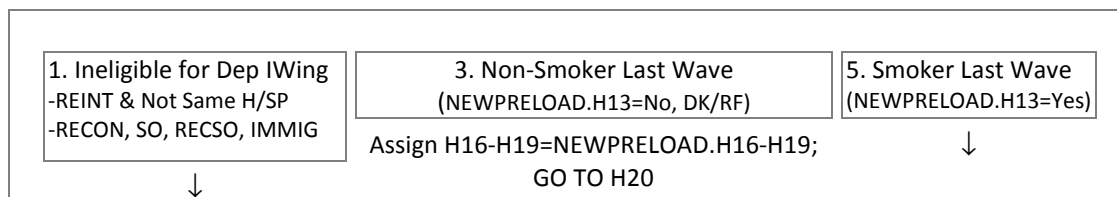
*Dependent Interviewing for Reinterviews*

H16. [CYNAMF CYNAML]: [CYAQRTH], [CYFUHU], Age [AGEIWDATE]

Did [you / HEAD / SP] ever smoke cigarettes?

 → GO TO H20

↓

Dependent Interviewing for Reinterviews

H17. [CYNAMF CYNAML]: [CYAQRTH], [CYFUHU], Age [AGEIWDATE]

On average, how many cigarettes per day did [you / he / she] smoke?

- DEFINITION: A standard pack of American cigarettes contains 20 cigarettes
- For one cigarette or less per day, ENTER [1]

Dependent Interviewing for Reinterviews

H18. [CYNAMF CYNAML]: [CYAQRTH], [CYFUHU], Age [AGEIWDATE]

How old [were you / was [HEAD / SP]] when [you / he / she] last smoked cigarettes regularly?

Dependent Interviewing for Reinterviews

H19. [CYNAMF CYNAML]: [CYAQRTH], [CYFUHU], Age [AGEIWDATE]

How old [were you / was [HEAD / SP]] when [you / he / she] first smoked cigarettes regularly?

H20. [CYNAMF CYNAML]: [CYAQRTH], [CYFUHU], Age [AGEIWDATE]

[Do you / Does [HEAD / SP]] ever drink any alcoholic beverages such as beer, wine, or liquor?

 → GO TO H22

↓

H21A. [CYNAMF CYNAML]: [CYAQRTH], [CYFUHU], Age [AGEIWDATE]

In the last year, on average, how often did [you / [HEAD / SP]] have any alcohol to drink? Would you say:
less than once a month, about once a month, several times a month, about once a week, several times a week, or every day?

- If R says "Did not drink in the last year", ENTER [1]

→ GO TO H22

↓

H21B. [CYNAMF CYNAML]: [CYAQRTH], [CYFUHU], Age [AGEIWDATE]

In the last year, on the days [you / he / she] drank, about how many drinks did [you / he / she] have?

- If R says “Did not drink in the last year”, ENTER [0]

H21C. [CYNAMF CYNAML]: [CYAQRTH], [CYFUHU], Age [AGEIWDATE]

In the last year, on how many days [have you / has [he / She]] had [*MALE*: five / *FEMALE*: four] or more drinks on one occasion?

- ENTER [0] for None

H22. [CYNAMF CYNAML]: [CYAQRTH], [CYFUHU], Age [AGEIWDATE]

About how much [do you / does [HEAD / SP]] weigh?

- ENTER weight in pounds or PRESS [Enter] to continue to next screen for kilograms
- If more than 400 pounds, ENTER [400]



GO TO H23FT

H22KILO. [CYNAMF CYNAML]: [CYAQRTH], [CYFUHU], Age [AGEIWDATE]

(About how much [do you / does [HEAD / SP]] weigh?)

- ENTER weight in kilograms
- If more than 180 kilograms, ENTER [180]

H23FT. [CYNAMF CYNAML]: [CYAQRTH], [CYFUHU], Age [AGEIWDATE]

How tall [are you / is [HEAD / SP]]?

- ENTER height in feet and inches or PRESS [Enter] to continue to next screen for meters



H23METER. [CYNAMF CYNAML]: [CYAQRTH], [CYFUHU], Age [AGEIWDATE]
(How tall [are you / is [HEAD / SP]]?)

- ENTER height in meters

→ GO TO H24CKPT



H23IN. [CYNAMF CYNAML]: [CYAQRTH], [CYFUHU], Age [AGEIWDATE]
(How tall [are you / is [HEAD / SP]]?)

[H23FT] feet and ___ inches

END H1_H23

H24CKPT. CAI Checkpoint: Whether Spouse/Partner in FU

| | | |
|--|--|---|
| <input type="text" value="1. Spouse/Partner (CYFUHU=FU, FUMI & CYAQRTH=201-222)"/> | → Repeat H1-H23; Then GO TO H25CKPT | <input type="text" value="5. No Spouse/Partner"/> |
| | | ↓ |

Childhood Health

SECTION_H.H25_H45[1-2] [1]=R (or current Head if R=OFUM, Proxy), [2]=R's spouse or partner (or current SP if R=OFUM, Proxy)

H25CKPT. CAI Checkpoint: Who Is R; Whether Childhood Report Needed

| R=Head (RESPONDENT=1) | | R=Spouse/Partner (RESPONDENT=2, 3) | | R=OFUM or Proxy (RESPONDENT=4 or 7) | | 7. All Others (Any R) |
|--|---|--|---|---|---|--------------------------|
| 1. H's Self-Rpt Needed (H's CHREPORT =0, 2, 3, 6) | 2. SP's Proxy-Rpt Needed (SP's CHREPORT =0, 1, 3, 5) | 3. SP's Self-Rpt Needed (SP's CHREPORT =0, 2, 3, 6) | 4. H's Proxy-Rpt Needed (H's CHREPORT =0, 1, 3, 5) | 5. H's Proxy-Rpt Needed (H's CHREPORT =0, 1) | 6. SP's Proxy-Rpt Needed (SP's CHREPORT =0, 1) | GO TO H48CKPT |
| ↓ Loop 1 | ↓ Loop 2 | ↓ Loop 1 | ↓ Loop 2 | ↓ Loop 1 | ↓ Loop 2 | |

HEALTHAQSN. AQSN of Current Head (Spouse/Partner)

REPORTAQSN. AQSN of Respondent

H25_INTRO. [CYNAMF CYNAML]: [CYAQRTH], [CYFUHU], Age [AGEIWDATE]

These next questions ask about [your / [HEAD / SP]'s] health during childhood, that is, before age 17. [R=OFUM, PROXY: I understand that it may be difficult for you to answer these questions, but please do your best.]

- ENTER [1] to continue

1. Continue

H25. [CYNAMF CYNAML]: [CYAQRTH], [CYFUHU], Age [AGEIWDATE]

Consider [your / [HEAD / SP]'s] health while [you were / [he / she] was] growing up, before [you were / [he / she] was] 17 years old. Would you say that [your / his / her] health during that time was excellent, very good, good, fair or poor?

1. Excellent 2. Very good 3. Good 4. Fair 5. Poor

H26. (H1D) [CYNAMF CYNAML]: [CYAQRTH], [CYFUHU], Age [AGEIWDATE]

When [you were / [he / she] was] growing up, before [you were / [he / she] was] 17 years old, did [you / he / she] miss a month or more of school because of a health problem?

1. Yes 5. No

H27. [CYNAMF CYNAML]: [CYAQRTH], [CYFUHU], Age [AGEIWDATE]

Before [you were / [he / she] was] 17 years old, did [you / he / she] have any of the following childhood diseases: Measles?

1. Yes 5. No

H28. [CYNAMF CYNAML]: [CYAQRTH], [CYFUHU], Age [AGEIWDATE]

(Before [you were / [he / she] was] 17 years old, did [you / he / she] have...)
Mumps?

1. Yes 5. No

H29. [CYNAMF CYNAML]: [CYAQRTH], [CYFUHU], Age [AGEIWDATE]

(Before [you were / [he / she] was] 17 years old, did [you / he / she] have...)
Chicken pox?

1. Yes 5. No

- H30. [CYNAMF CYNAML]: [CYAQRTH], [CYFUHU], Age [AGEIWDATE]
(Before [you were / [he / she] was] 17 years old, did [you / he / she] have...)
Difficulty seeing, even with eye glasses or prescription lenses?
 1. Yes 5. No
- H31. [CYNAMF CYNAML]: [CYAQRTH], [CYFUHU], Age [AGEIWDATE]
Did one or both of [your / his / her] parents or guardians smoke during [your / his / her] childhood? If Yes: Was that one or both of them?
 1. Yes, one of them 2. Yes, both of them 5. No, none of them
- H32. [CYNAMF CYNAML]: [CYAQRTH], [CYFUHU], Age [AGEIWDATE]
Before [you were / [he / she] was] 17 years old, did [you / he / she] have any of the following childhood diseases:
Asthma?
 1. Yes 5. No
- H33. [CYNAMF CYNAML]: [CYAQRTH], [CYFUHU], Age [AGEIWDATE]
(Before [you were / [he / she] was] 17 years old, did [you / he / she] have...)
Diabetes?
 1. Yes 5. No
- H34. [CYNAMF CYNAML]: [CYAQRTH], [CYFUHU], Age [AGEIWDATE]
(Before [you were / [he / she] was] 17 years old, did [you / he / she] have...)
A respiratory disorder such as bronchitis, wheezing, hay fever, shortness of breath, or sinus infection?
 1. Yes 5. No
- H35. [CYNAMF CYNAML]: [CYAQRTH], [CYFUHU], Age [AGEIWDATE]
(Before [you were / [he / she] was] 17 years old, did [you / he / she] have...)
A speech impairment?
 1. Yes 5. No
- H36. [CYNAMF CYNAML]: [CYAQRTH], [CYFUHU], Age [AGEIWDATE]
(Before [you were / [he / she] was] 17 years old, did [you / he / she] have...)
An allergic condition?
 1. Yes 5. No
- H37. [CYNAMF CYNAML]: [CYAQRTH], [CYFUHU], Age [AGEIWDATE]
(Before [you were / [he / she] was] 17 years old, did [you / he / she] have...)
Heart trouble?
 1. Yes 5. No
- H38. [CYNAMF CYNAML]: [CYAQRTH], [CYFUHU], Age [AGEIWDATE]
(Before [you were / [he / she] was] 17 years old, did [you / he / she] have...)
Chronic ear problems or infections?
 1. Yes 5. No
- H39. [CYNAMF CYNAML]: [CYAQRTH], [CYFUHU], Age [AGEIWDATE]
Before [you were / [he / she] was] 17 years old, did [you / he / she] have any of the following childhood diseases:
Epilepsy or seizures?
 1. Yes 5. No

H40. [CYNAMF CYNAML]: [CYAQRTH], [CYFUHU], Age [AGEIWDATE]
 (Before [you were / [he / she] was] 17 years old, did [you / he / she] have...)
 Severe headaches or migraines?

1. Yes 5. No

H41. [CYNAMF CYNAML]: [CYAQRTH], [CYFUHU], Age [AGEIWDATE]
 (Before [you were / [he / she] was] 17 years old, did [you / he / she] have...)
 Stomach problems?

1. Yes 5. No

H42. [CYNAMF CYNAML]: [CYAQRTH], [CYFUHU], Age [AGEIWDATE]
 (Before [you were / [he / she] was] 17 years old, did [you / he / she] have...)
 High blood pressure?

1. Yes 5. No

H43. [CYNAMF CYNAML]: [CYAQRTH], [CYFUHU], Age [AGEIWDATE]
 (Before [you were / [he / she] was] 17 years old, did [you / he / she] have...)
 Depression?

1. Yes 5. No

H44. [CYNAMF CYNAML]: [CYAQRTH], [CYFUHU], Age [AGEIWDATE]
 (Before [you were / [he / she] was] 17 years old, did [you / he / she] have...)
 Drug or alcohol problems?

1. Yes 5. No

H45. [CYNAMF CYNAML]: [CYAQRTH], [CYFUHU], Age [AGEIWDATE]
 (Before [you were / [he / she] was] 17 years old, did [you / he / she] have...)
 Any other emotional or psychological problems?

1. Yes 5. No

H46 Rule: Whether Any Health Conditions Endorsed

| |
|---|
| <input type="checkbox"/> At Least One Condition H32-H45=Yes <input type="checkbox"/> All Others → GO TO CH END Rule |
| ↓ |

Childhood Health EHC

SECTION_H.H25_H45[1-2].EHC [1]=R (or current Head if R=OFUM, Proxy), [2]=R's spouse or partner (or current SP if R=OFUM, Proxy)
 CALAQSN. AQSN of Current Head (Spouse/Partner)

CAL_INTRO. [CYNAMF CYNAML]: [CYAQRTH], [CYFUHU], Age [AGEIWDATE]

We would like to know more about how old [you were / [HEAD / SP] was] when [you / he / she] had the health condition(s) we just talked about, but first I want to ask you about some other things that may have happened in [your / his / her] childhood.

- ENTER [1] to continue

1. Continue

Childhood Health Landmarks Timeline

Person: [CYNAMF CYNAML], [CYAQRTH], Age: [AGEIWDATE], DOB: [CY(MO/DY/YR)BRN]

PARENTEPEHC[0-16]. If [your / [HEAD / SP]'s] parents or guardians separated during [your / his / her] childhood, please tell me how old [you were / [he / she] was] at the time of each separation, starting with the first time they separated. Any other separations?

MOVEEHC[0-16]. If [you / [HEAD / SP]] moved during [your / his / her] childhood, please tell me how old [you were / [he / she] was] at the time of each move, starting with the first move. Any other moves?

SCHOOLEHC[0-16]. At what age did [you / [HEAD / SP]] first start going to school? If [you / he / she] changed schools during [your / his / her] childhood, please tell me how old [you were / [he / she] was] each time, starting with the first time. Any other school changes?

AGE CELLS

RESPONSES

HEALTH EHC Rule: Which Conditions Endorsed

Childhood Health Conditions Timeline

Person: [CYNAMF CYNAML], [CYAQRTH], Age: [AGEIWDATE], DOB: [CY(MO/DY/YR)BRN]

At what age did [you / [HEAD / SP]] first have [an allergic condition / heart trouble / chronic ear problems or infections / epilepsy or seizures / severe headaches or migraines / stomach problems / high blood pressure / depression / drug or alcohol problems / any other emotional or psychological problems]? Until what age did [you / he / she] have it?

- PROBE for all ages 0-16 at which condition occurred
- IF R SAYS "Did not have that condition", CLICK any cell - SELECT Denial - then ENTER NOTE
- PROBE: If you don't know the exact age, please give us your best guess
- PROBE for age using landmarks, starting with the earliest landmark

For age at which condition ended:

- IF R SAYS "Older than 16", CLICK 17+ - SELECT Yes - ENTER Age
- IF R SAYS "Still have it", CLICK 17+ - SELECT Yes - SELECT Still Have It

AGE CELLS

ASTHMAEHC[0-16]

DIABETSEHC[0-16]

RESPDISORDEREHC[0-16]

SPEECHIMPAIREHC[0-16]

ALLERGYEHC[0-16]

HEARTTROUBLEEHC[0-16]

EARPROBLEMSEHC[0-16]

EPILEPSYEHC[0-16]

HEADACHESEHC[0-16]

STOMACHPROBEHC[0-16]

HIGHBPEHC[0-16]

DEPRESSIONEHC[0-16]

DRUGALCOHOLEHC[0-16]

OTHERPROBEHC[0-16]

RESPONSES

AGE CELLS

ASTHMAEHC[AGEGR17]

DIABETSEHC[AGEGR17]

RESPDISORDEREHC[AGEGR17]

SPEECHIMPAIREHC[AGEGR17]

ALLERGYEHC[AGEGR17]

HEARTTROUBLEEHC[AGEGR17]

EARPROBLEMSEHC[AGEGR17]

EPILEPSYEHC[AGEGR17]

HEADACHESEHC[AGEGR17]

STOMACHPROBEHC[AGEGR17]

HIGHBPEHC[AGEGR17]

DEPRESSIONEHC[AGEGR17]

DRUGALCOHOLEHC[AGEGR17]

OTHERPROBEHC[AGEGR17]

RESPONSES

CH END Rule: Whether SP In FU

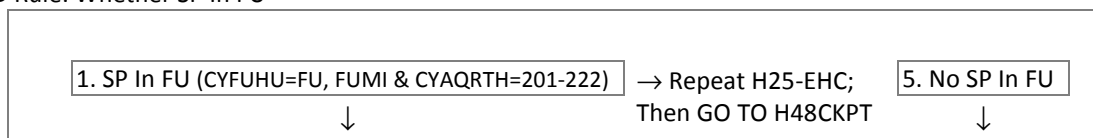

END EHC

END H25_H45

H48CKPT. CAI Checkpoint: Whether There are OFUMs in the FU

| | |
|--|------------------------------|
| 1. OFUMs (CYFUHU=FU, FUMI & CYAQRTH>222) | 5. No OFUMs → GO TO H50ACKPT |
|--|------------------------------|

↓

H49. Now about the rest of your family living there — are any family members in poor health?

| | |
|--------|------------------------|
| 1. Yes | 5. No → GO TO H50ACKPT |
|--------|------------------------|



H50. Who is that?

- ENTER all that apply
- PROBE: Any others?

| | |
|--|---|
| 1 – 24. [CYNAMF CYNAML], [CYAQRTH], [CYFUHU] | <i>AQSN list of OFUMs w/CYFUHU=FU, FUMI</i> |
|--|---|

Dementia Screener (OFUM and Non-Current Head/Spouse/Partner)

H50B-H50I: All rights reserved. Copyright 2008 by Washington University in St. Louis, Missouri.

H50ACKPT. CAI Checkpoint: Whether OFUM Age 65+ and FU/Moved Out/Health/Other Institution; Whether Head or Spouse/Partner Age 65+ and Moved Out/Health/Other Institution

| | | |
|---|---|--------------------------------|
| 1. OFUM Age 65+ (AGEIWDATE=65+ & CYFUHU=FU, FUMI, MO, HLTH, OTH INST & CYAQRTH>222) | 3. H/SP Age 65+ (AGEIWDATE=65+ & CYFUHU=MO, HLTH, OTH INST & CYAQRTH=101-222) | 5. All Others → GO TO H58 RULE |
|---|---|--------------------------------|

↓

SECTION_H.H50A_H50I[1-24] [1-24]=AQSN of FU Member

AQSN. AQSN of FU Member

H50B. [CYNAMF CYNAML]: [CYAQRTH], [CYFUHU], Age [AGEIWDATE]

Next, we'd like to know about changes that [you / [CYNAMF CYNAML]] may have had in the last several years [*R IS NOT THIS FU MEMBER: because of a thinking or memory problem*].

In the last several years, has there been a change in problems [you / he / she] may have with judgment, for example, problems making decisions, making bad financial decisions, or with thinking?

| | |
|------------------|------------------|
| 1. Yes, a change | 5. No, no change |
|------------------|------------------|

H50C. [CYNAMF CYNAML]: [CYAQRTH], [CYFUHU], Age [AGEIWDATE]

In the last several years, has there been a change in...

The amount of interest [you / he / she] may have in hobbies or activities?

| | |
|------------------|------------------|
| 1. Yes, a change | 5. No, no change |
|------------------|------------------|

H50D. [CYNAMF CYNAML]: [CYAQRTH], [CYFUHU], Age [AGEIWDATE]

(In the last several years, has there been a change in...)

[Your / His / Her] repeating the same things over and over, such as questions, stories, or statements?

| | |
|------------------|------------------|
| 1. Yes, a change | 5. No, no change |
|------------------|------------------|

H50E. [CYNAMF CYNAML]: [CYAQRTH], [CYFUHU], Age [AGEIWDATE]

(In the last several years, has there been a change in ...)

The trouble [you / he / she] may have learning how to use a tool, appliance or gadget like a TV remote?

| | |
|------------------|------------------|
| 1. Yes, a change | 5. No, no change |
|------------------|------------------|

H50F. [CYNAMF CYNAML]: [CYAQRTH], [CYFUHU], Age [AGEIWDATE]

(In the last several years, has there been a change in ...)
[Your / His / Her] forgetting the correct month or year?

1. Yes, a change 5. No, no change

H50G. [CYNAMF CYNAML]: [CYAQRTH], [CYFUHU], Age [AGEIWDATE]

(In the last several years, has there been a change in...)

The trouble [you / he / she] may have handling complicated money matters, like balancing a checkbook or paying bills?

1. Yes, a change 5. No, no change

H50H. [CYNAMF CYNAML]: [CYAQRTH], [CYFUHU], Age [AGEIWDATE]

(In the last several years, has there been a change in...)

The trouble [you / he / she] may have remembering appointments?

1. Yes, a change 5. No, no change

H50I. [CYNAMF CYNAML]: [CYAQRTH], [CYFUHU], Age [AGEIWDATE]

(In the last several years, has there been a change in...)

Daily problems [you / he / she] may have with thinking and/or memory?

1. Yes, a change 5. No, no change

H50J Rule: Whether More Eligible 65+ Year Olds

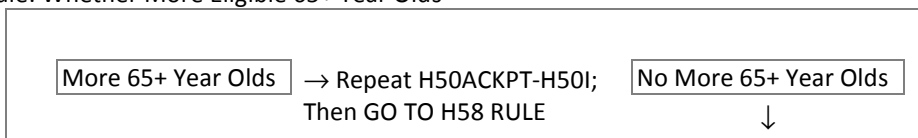

END H50A_H50I

H58 Rule: Who Is R

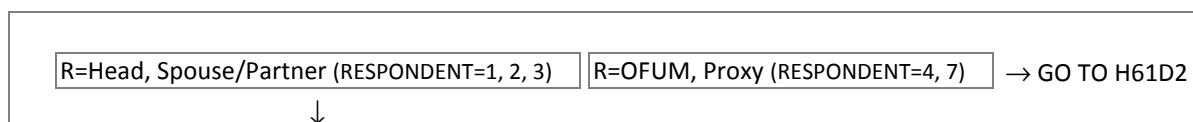

H59A. Now, I am going to ask you (Respondent: [CYNAMF CYNAML]) some questions about feelings you may have had over the PAST 30 days. Please answer using one of the following choices: All of the time, most of the time, some of the time, a little of the time, none of the time.

In the past 30 days, about how often did you feel...

So sad nothing could cheer you up?

1. All of the time 2. Most of the time 3. Some of the time 4. A little of the time 5. None of the time

H59B. (In the past 30 days, about how often did you feel...)

Nervous?

(Would you say all of the time, most of the time, some of the time, a little of the time, or none of the time?)

1. All of the time 2. Most of the time 3. Some of the time 4. A little of the time 5. None of the time

H59C. (In the past 30 days, about how often did you feel...)

Restless or fidgety?

(Would you say all of the time, most of the time, some of the time, a little of the time, or none of the time?)

1. All of the time 2. Most of the time 3. Some of the time 4. A little of the time 5. None of the time

H59D. (In the past 30 days, about how often did you feel...)

Hopeless?

(Would you say all of the time, most of the time, some of the time, a little of the time, or none of the time?)

1. All of the time 2. Most of the time 3. Some of the time 4. A little of the time 5. None of the time

H59E. (In the past 30 days, about how often did you feel...)

That everything was an effort?

(Would you say all of the time, most of the time, some of the time, a little of the time, or none of the time?)

1. All of the time 2. Most of the time 3. Some of the time 4. A little of the time 5. None of the time

H59F. (In the past 30 days, about how often did you feel...)

Worthless?

(Would you say all of the time, most of the time, some of the time, a little of the time, or none of the time?)

1. All of the time 2. Most of the time 3. Some of the time 4. A little of the time 5. None of the time

H59G Rule: Whether One or More H59A-H59F Endorsed As All/Most/Some

| | | |
|---------------------------------------|------------|------------|
| One or More H59A-H59F = All/Most/Some | All Others | → GO H61D2 |
| ↓ | | |

H59J. How much do these feelings usually interfere with your life or activities - a lot, some, a little, or not at all?

1. A lot 2. Some 3. A little 5. Not at all

H61D2. Next, please think about your [family's] health insurance, including coverage obtained through employment, or purchased directly, or through a government program like Medicare and Medicaid.

[Do you / Does anyone in your family] currently have health insurance or health care coverage?

1. Yes 5. No → GO TO H61K

↓

H61D3 Rule: Number of FU Members

| | | |
|-------------------------|--------------------|--|
| More Than One FU Member | Only One FU Member | → Assign H61D3 & H61DAQSN =AQSN of FU Member; Then GO TO H61E RULE |
| ↓ | | |

H61D3. Who is covered (by health insurance)?

- ENTER all that apply
- PROBE: Any others?

1 – 24. [CYNAMF CYNAML], [CYAQRTH], [CYFUHU] DK/RF → GO TO H61K

AQSN list of FU Members w/CYFUHU=FU, FUMI

↓

H61D4CKPT. Number of FU Members Selected at H61D3

| | | |
|------------------|-------------------|----------------------------|
| 1. One FU Member | → GO TO H61E RULE | 5. More Than One FU Member |
| ↓ | | |

H61D4. Does everyone have the same health insurance or health care coverage?

[FU Members With Health Care Coverage/Insurance:](#)
[H61D3 Selections]

1. Yes → GO TO H61E 5. No



H61E Rule: For Each FU Member - Whether Selected at H61D3

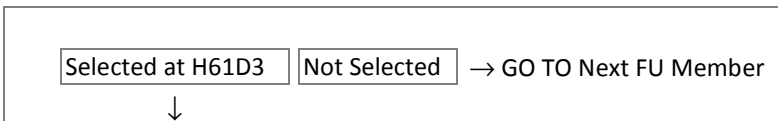

SECTION_H.H61E_H61G[1-24] [1-24]=AQS of FU Member

H61DAQSN. AQS of FU Member

H61E. *[H61D4<>YES: [CYNAMF CYNAML], [CYAQRTH], [CYFUHU]]*

1st ITERATION: What kind of health insurance or health care coverage [*H61D4=YES:* is that / *ALL OTHERS:* do you / does [CYNAMF]] have)?

ALL OTHERS: What about [you / CYNAMF] (what kind of health insurance or health care coverage [do you / does CYNAMF] have)?

- **IF needed:** We would like to know whether [your/[CYNAMF]'s] health insurance or health care coverage is provided through an employer, is privately purchased, is a government program like Medicare or Medicaid, or what?
- **IF R mentions government plan:** Is that Medicare, Medi-gap, Medicaid or a state program, military provided such as Tricare, ChampUS or ChampVA, Indian health insurance, or some other plan?
- **IF needed (if Affordable Care Act/Obamacare/Health Insurance Exchanges mentioned):** Was that a privately purchased health insurance plan or Medicaid/[STATEMEDPROG]/[SCHIPNAME]?
- **ENTER all that apply**
- **PROBE:** Any others?

| | | | |
|--|---|--------------------------|--|
| 1. Employer provided health insurance (Current or former employer) | | | |
| 2. Private health insurance purchased | 3. Medicare | 4. Medi-Gap/Supplemental | |
| 5. Medicaid/[STATEMEDPROG]/[SCHIPNAME] | 6. Military Health Care/Tricare (Active duty) | | |
| 7. Tricare/Champus/ChampVA (Dependents, veterans) | 8. Indian Health Insurance | | |
| 11. Veterans Administration (VA) | 97. Other-specify | | |

SIGNAL FOR MEDICARE OR MEDICAID NOT SELECTED AT H61E:

IWER: READ QUESTION TO VERIFY MEDICARE AND/OR MEDICAID COVERAGE:

How about [*3 NOR 5 SELECTED:* Medicare and Medicaid, [*PYSTATERESIDE<>FC/DK/RF:* [STATEMEDPROG], [SCHIPNAME]] / *3 SELECTED BUT NOT 5:* Medicaid, [*PYSTATERESIDE<>FC/DK/RF:* [STATEMEDPROG], [SCHIPNAME]] / *5 SELECTED BUT NOT 3:* Medicare]?

([*H61D4=YES:* Does your family / *ALL OTHERS:* [Do you / Does [CYNAMF]] have (this / any of these)?)

IF YesENTER [Close] or [Goto] to make Medicare / Medicaid selection(s)

IF No, Dk, RfENTER [Suppress] to go forward with interview

H61ESPEC Rule: H61E Selection

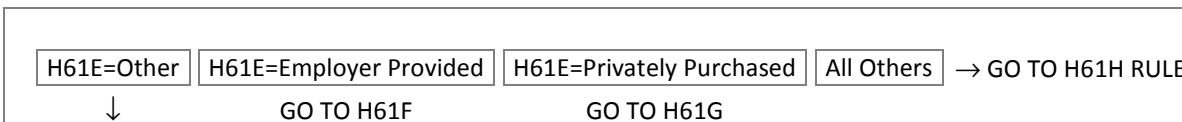

H61E=Other Plan

H61ESPEC. [H61D4<>YES: [CYNAMF CYNAML], [CYAQRTH], [CYFUHU]]

Could you tell me a little more about that other plan or program?

[Health Plan\(s\) Selected:](#)

[H61E Selections]

String 100

H61E2CKPT. If FU Members Have Different Insurance - Whether FU Member is 18 Years Old or Younger

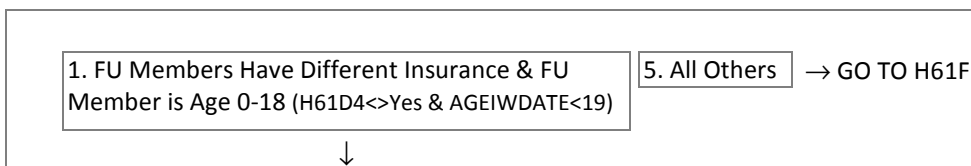

H61E2. [H61D4<>YES: [CYNAMF CYNAML], [CYAQRTH], [CYFUHU]]

Interviewer Checkpoint:

- Is that [STATE SCHIP PROGRAM NAME], the state health insurance plan for uninsured children?
- ENTER Yes or No; ASK R only if you are unclear about the answer

[Health Plan\(s\) Selected:](#)

[H61E Selections]

1. Yes

5. No

H61E=Employer Provided Health Insurance

H61F. [H61D4<>YES: [CYNAMF CYNAML], [CYAQRTH], [CYFUHU]]

Whose employer provides [H61D4=YES: this / ALL OTHERS: [your / CYNAMF's]] health insurance?

- ENTER all that apply, maximum of 3 selections
- PROBE: Any others?

[Health Plan\(s\) Selected:](#)

[H61E Selections]

1 – 24. [CYNAMF CYNAML], [CYAQRTH], [CYFUHU] *AQSN list of FU Members w/CYFUHU=FU, FUMI*

25. Parent of [FU MEMBER], outside of FU

97. Other person outside of FU-specify (H61FSPEC. Specify (String 100))

H61E= Private Health Insurance

H61G. [H61D4<>YES: [CYNAMF CYNAML], [CYAQRTH], [CYFUHU]]

Who is the policy holder on [this / [your / CYNAMF's]] private health insurance?

- IF needed: The policy holder is the person who purchased the insurance; other family members who are covered are called dependents.
- ENTER all that apply, maximum of 3 selections
- PROBE: Any others?

[Health Plan\(s\) Selected:](#)

[H61E Selections]

1 – 24. [CYNAMF CYNAML], [CYAQRTH], [CYFUHU] *AQSN list of FU Members w/CYFUHU=FU, FUMI*

25. Parent of [FU MEMBER], outside of FU

97. Other person outside of FU-specify (H61GSPEC. Specify (String 100))

END H61E_H61G

H61H Rule: If FU Members Have Different Insurance - Whether More FU Members Selected at H61D3

| | | |
|---|--|-----------------|
| FU Members Have Different Insurance (H61D4<>Yes) & More FU Members | → Repeat H61E-H61G; Max=24; Then GO TO H61JCKPT | All Others ↓ |
|---|--|-----------------|

H61JCKPT. CAI Checkpoint: Whether Any FU Member Has Employer Provided or Privately Purchased Insurance

| | | | |
|-------------------------------|---------------------------------|---------------|--------------|
| 1. Employer Provided (H61E=1) | 2. Privately Purchased (H61E=2) | 5. All Others | → GO TO H61K |
| ↓ | | | |

H61J. How much are your [and your family's] health insurance premiums [, altogether]? Please only include amounts that you [and your family] paid, either directly or through automatic deductions from pay. Do not include amounts paid by someone outside of your family.

- ENTER amount here, then SELECT unit of time on next screen (Week, Two Weeks, Month, Year)

→ GO TO H61K → GO TO H61JD



H61JPER. The amount entered is: [H61J] per ___

- SELECT the unit of time below

| | | | | |
|------------|--------------|----------|---------|---|
| 3. Week | 4. Two weeks | 5. Month | 6. Year | 7. Other-specify (H61JPERSPEC. Specify. (String 100)) |
| GO TO H61K | | | | |

H61JD. Are they \$200 or more per month?

| | | | | | |
|--|-------|--|--------|--------------|-------|
| 1. Yes | | 5. No | DK/RF | → GO TO H61K | |
| ↓ | | ↓ | | | |
| H61JE. Are they \$350 or more per month? | | H61JF. Are they \$100 or more per month? | | | |
| 1. Yes | 5. No | DK/RF | 1. Yes | 5. No | DK/RF |

H61K. Did [you / [HEAD]] [or anyone else in the family living there] go without health insurance at any time during [P2YEAR] or [PYEAR]?

→ GO TO H62CKPT



H61L Rule: Number of FU Members

| | | |
|---------------|---|-------------------------|
| One FU Member | → Assign H61L & H61MAQSN =AQSN of FU Member; Then GO TO H61M RULE | More Than One FU Member |
| | | ↓ |

H61L. Who was that?

- ENTER all that apply
- PROBE: Any others?

→ GO TO H64

AQSN list of FU Members w/CYFUHU=FU, FUMI and Birth Year<CYEAR



SECTION_H.H61M_H61N[1-24] [1-24]=AQS of FU Member

H61M Rule: Whether FU Member Born in P2YEAR or Earlier

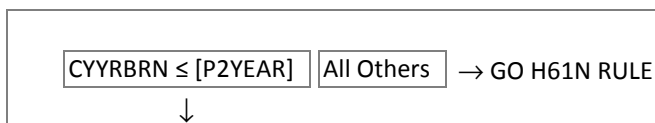

H61MAQSN. AQS of FU Member

H61M. [CYNAMF CYNAML], [CYAQRTH], [CYFUHU]

For how many months in [P2YEAR] [were you / was [CYNAMF]] uninsured?

0 – 12

H61N Rule: Whether FU Member Born in PYEAR or Earlier

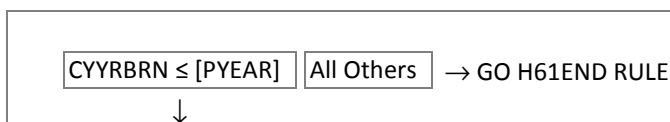

H61N. [CYNAMF CYNAML], [CYAQRTH], [CYFUHU]

(For how many months) in [PYEAR] ([were you / was [CYNAMF]] uninsured)?

0 – 12

H61 END Rule: Whether More FU Members Selected at H61L

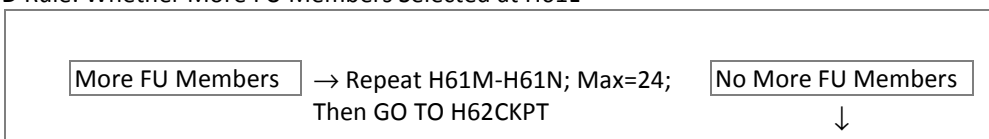
**END H61M_H61N**

H62CKPT. CAI Checkpoint: If R is Head or Spouse/Partner - Whether Medicare# Already Collected; Age; Has Medicare

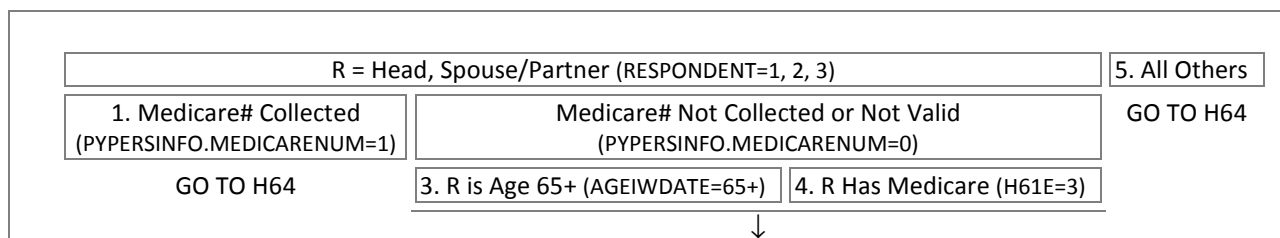

H62A. We would like to learn more about people's health and how health care is used. The best place to get this information is Medicare. We are therefore asking F.E.S. (Family Economics Study) families to let us access these records. [NO CHRONIC CONDITIONS ENDORSED (H5): Even if you don't have any health conditions, it is important for statistical purposes to get this information from Medicare.]

Under the Privacy Act of 1974, providing your number is a voluntary decision. The benefits you may be receiving under Medicare will not be affected in any way by your decision.

Could you tell me your Medicare number for this purpose?

1. Yes 5. No → GO TO H64

↓

H62B. Is that a Medicare Claim number or a Railroad Retirement Board Claim number?

1. Medicare Claim Number 2. Railroad Retirement Board Claim Number DK/RF → GO TO H64

H62C. What is your complete Medicare number, including the letters or number at the end?

- ENTER the 9-digit Medicare number, then any letter(s) and number(s) at the end

| | | | | | | |
|---|-----|-----|---|---|---|---|
| 1 | 2 | 3 | - | 4 | 5 | - |
| 6 | 7 | 8 | 9 | - | | |
| A | 1/B | 2/C | | | | |

H62D. Is that a 9-digit or 6-digit number?

1. 9-digit

2. 6-digit

H62E. What is your complete Railroad Retirement number including the letter(s) at the beginning?

- ENTER up to 3 letter(s) at the beginning and then the 9-digit number
- If there are less than 3 letter(s), press the space bar to enter blank(s), then ENTER the letter(s)

| | | | | | | |
|---|---|---|---|---|---|---|
| A | B | C | - | 1 | 2 | 3 |
| 4 | 5 | - | 6 | 7 | 8 | 9 |

H62F. What is your complete Railroad Retirement number including the letter(s) at the beginning?

- ENTER up to 3 letter(s) at the beginning and then the 6-digit number
- If there are less than 3 letter(s), press the space bar to enter blank(s), then ENTER the letter(s)

| | | | | | | |
|---|---|---|---|---|---|--|
| A | B | C | - | | | |
| 1 | 2 | 3 | 4 | 5 | 6 | |

H64. These next questions are about health care expenditures that [you [and your family] / they] may have had during [PYEAR]. About how much did you [and your family] pay out-of-pocket for nursing home and hospital bills in [PYEAR]?

\$ 0 – 999,997 → GO TO H70

DK/RF

H65. Would it amount to \$1,000 or more?

1. Yes

5. No DK/RF

H66. \$2,000 or more?

1. Yes 5. No DK/RF

H69. \$500 or more?

1. Yes 5. No DK/RF

GO TO H70

GO TO H70

H67. \$8,000 or more?

1. Yes 5. No DK/RF

H70. About how much did you [and your family] pay out-of-pocket for doctor, outpatient surgery, and dental bills in [PYEAR]?

\$ 0 – 999,997 → GO TO H76

DK/RF

H71. Would it amount to \$1,000 or more?

1. Yes

5. No DK/RF → GO TO H76

H72. \$2,500 or more?

1. Yes 5. No DK/RF

H74. \$500 or more?

1. Yes 5. No DK/RF

H76. About how much did you [and your family] pay out-of-pocket for prescriptions, in-home medical care, special facilities, and other services in [PYEAR]?

→ GO TO SECTION J



H77. Would it amount to \$500 or more?



H78. \$2,500 or more?



H79. \$10,000 or more?

GO TO SECTION J

H81. \$200 or more?

GO TO SECTION J

→ GO TO SECTION J



END SECTION_H

Section J: Marriages and Children

[TOC](#)

J1CKPT. Section J Qualifier

| | | | | | |
|---|--|--|---|--|--|
| GROUP 1 | | | | | |
| REINTERVIEW and SPLITOFF INTERVIEWs | | | | | |
| <u>Same Married Male Head and Female Spouse As Last Wave</u> (CYAQRTH/PYAQRTH=101; CYFUHU/PYFUHU=FU) & (CYAQRTH/PYAQRTH=202; CYFUHU/PYFUHU=FU) | | | | | |
| 1. Type A. Female Spouse Age 15-44 (AGEIWDATE=15-44) | | | 2. Type ANoJ. Female Spouse Age 45+ (AGEIWDATE>44, DK/RF) | | |
| AS A <u>COUPLE</u> , ASK OWN/ADOPTED KIDS (J27CKPT-AS8A) | | | NO SECTION J FOR THIS COUPLE | | |
| GROUP 2 | | | | | |
| REINTERVIEW and SPLITOFF INTERVIEWs | | | | | |
| <u>Head or Spouse/Partner Was a Head or Spouse/Partner Last Wave</u> (PYAQRTH/CYAQRTH=101-222; CYFUHU/PYFUHU=FU) | | | | | |
| 3. Type B1. Male (CYAQRTH=101, 201, 221; PYAQRTH =101-222; CYFUHU/PYFUHU=FU) | | 4. Type B2. Female Age 15-44 (CYAQRTH=102, 202, 222; PYAQRTH = 101-222; CYFUHU/PYFUHU=FU; AGEIWDATE=15-44) | | 5. Type B3. Female Age 45+ (CYAQRTH=102, 202, 222; PYAQRTH = 101-222; CYFUHU/PYFUHU=FU; AGEIWDATE>44, DK/RF) | |
| ASK MARRIAGE UPDATE (J2-J12YR) and OWN/ADOPTED KIDS (J27CKPT-AS8A) | | | ASK MARRIAGE UPDATE (J2-J12YR) | | |
| GROUP 3 | | | | | |
| ALL INTERVIEWs | | | | | |
| <u>New or Mover-In PY-INST Head or Spouse/Partner</u> (CYFUHU=FU, FUMI; PYFUHU=FU, FUMI, NULL) or (CYFUHU=FUMI; PYFUHU=INST) | | | | | |
| Male (CYAQRTH=101, 201, 221) | | | Female (CYAQRTH=102, 202, 222) | | |
| 6. Type C1A (REINT; SO) | | 11. Type C2A (REC; RECSO; IMMIG) | | 7. Type C1B (REINT; SO) | |
| 12. Type C2B (REC; RECSO; IMMIG) | | | | | |
| ASK ALL MARRIAGES (J12A-J26YR) and OWN/ADOPTED KIDS (J27CKPT-AS8A) | | | | | |
| <u>New or Mover-In OFUM</u> (CYAQRTH>222; CYFUHU=FU, FUMI) | | | | | |
| Age <15 (AGEIWDATE=<15, DK/RF) | | Age 15-44 (AGEIWDATE=15-44) | | Age 45+ (AGEIWDATE>44) | |
| 95. All Others C1 (REINT; SO) | | 96. All Others C2 (REC; RECSO; IMMIG) | | 9. Type C1D (REINT; SO) | |
| 10. Type C1NoJ (REINT; SO) | | 14. Type C2D (REC; RECSO; IMMIG) | | 15. Type C2NoJ (REC; RECSO; IMMIG) | |
| NO SECTION J FOR THIS PERSON | | ASK ALL MARRIAGES (J12A-J26YR) and OWN KIDS (J27CKPT- OS70) | | NO SECTION J FOR THIS PERSON | |
| <u>All Others</u> (CYAQRTH=101-982; CYFUHU=MO, DIED, INST) | | | | | |
| 97. All Others | | | | | |
| NO SECTION J FOR THIS PERSON | | | | | |

NOTE:

- J1CKPT[x] is assigned to each FU member where [x] is that person's AQSN, 1 - 24.
- Regardless of AQSN, the first loop of Section J is always asked about the current Head and the 2nd loop is always asked about the current Spouse/Partner if there is one in the FU.

SECTION_J[1-24] [1-24]=AQSN of FU Member

FIRST ITERATION OF SECTION J:

J1A. Now I have some questions about marriage and children.

- ENTER [1] to continue

1. Continue

J2. AQSN of FU Member

J3CKPT. CAI Checkpoint: (For Type B (J1CKPT=3, 4, 5)); Marital Status

| | | | | |
|---------------------------|---|----------------------------|--|---------------------------------|
| 1. Widowed (Marital=3) | 2. Separated (Marital=5); or Married Partner (Marital=1) | 3. Divorced (Marital=4) | 4. Married Head, Spouse, OFUM (Marital=1) | 5. Never Married (Marital=2) |
| ↓ | GO TO J6MO | GO TO J5MO | GO TO J7MO | GO TO J27CKPT |

SECTION_J[1-24].J4_J12 [1-24]=AQSN of FU Member

J4MO. [CYAQRTH], [CYNAMF CYNAML], age: [AGEIWDATE]

In what month and year [were you / was [HEAD / SP]] widowed?

- SELECT Month and [Enter] to go to next screen for year
- IF NECESSARY: What would be your best estimate?

| | | | | | |
|------------|-------------|--------------|-------------|--------------|--------------|
| 1. January | 2. February | 3. March | 4. April | 5. May | 6. June |
| 7. July | 8. August | 9. September | 10. October | 11. November | 12. December |
| 21. Winter | 22. Spring | 23. Summer | 24. Fall | | |

J4YR. [CYAQRTH], [CYNAMF CYNAML], age: [AGEIWDATE]

The month entered is: [J4MO]

- ENTER the year below

1901- [CYEAR] Actual year

9996 [P2YEAR]-[CYEAR], DK which year

9997 Before [P2YEAR], DK exact year

| | | | | |
|-----------------|--------------------|--|---|-------|
| 1901 - [P3YEAR] | [P2YEAR] - [CYEAR] | 9996. [P2YEAR] - [CYEAR], DK Which Year | 9997. Before [P2YEAR], DK Exact Year | DK/RF |
| GO TO J27CKPT | | GO TO J7MO | GO TO J27CKPT | |

J5MO. [CYAQRTH], [CYNAMF CYNAML], age: [AGEIWDATE]

In what month and year did [your / [HEAD / SP]]'s (divorce/annulment) become final?

- SELECT Month and [Enter] to go to next screen for year
- IF NECESSARY: What would be your best estimate?

| | | | | | |
|------------|-------------|--------------|-------------|--------------|--------------|
| 1. January | 2. February | 3. March | 4. April | 5. May | 6. June |
| 7. July | 8. August | 9. September | 10. October | 11. November | 12. December |
| 21. Winter | 22. Spring | 23. Summer | 24. Fall | | |

J5YR. [CYAQRTH], [CYNAMF CYNAML], age: [AGEIWDAT]E

The month entered is: [J5MO]

- ENTER the year below

1901- [CYEAR] Actual year

9996 [P2YEAR]-[CYEAR], DK which year

9997 Before [P2YEAR], DK exact year

| | | | | |
|-----------------|--------------------|--|---|-------|
| 1901 - [P3YEAR] | [P2YEAR] - [CYEAR] | 9996. [P2YEAR] - [CYEAR], DK Which Year | 9997. Before [P2YEAR], DK Exact Year | DK/RF |
| GO TO J27CKPT | | | GO TO J27CKPT | |

↓

J6MO. [CYAQRTH], [CYNAMF CYNAML], age: [AGEIWDAT]E

[MARRIED PARTNER: Earlier you reported that [R: you are / ALL OTHERS: [PARTNER] is] married.

In what month and year did [R: you and your spouse / ALL OTHERS: [HEAD / SP] and [his / her] spouse] stop living together?

- SELECT Month and [Enter] to go to next screen for year
- IF NECESSARY: What would be your best estimate?

| | | | | | |
|------------|-------------|--------------|-------------|--------------|--------------|
| 1. January | 2. February | 3. March | 4. April | 5. May | 6. June |
| 7. July | 8. August | 9. September | 10. October | 11. November | 12. December |
| 21. Winter | 22. Spring | 23. Summer | 24. Fall | | |

J6YR. [CYAQRTH], [CYNAMF CYNAML], age: [AGEIWDAT]E

The month entered is: [J6MO]

- ENTER the year below

1901- [CYEAR] Actual year

9996 [P2YEAR]-[CYEAR], DK which year

9997 Before [P2YEAR], DK exact year

| | | | | |
|-----------------|--------------------|--|---|-------|
| 1901 - [P3YEAR] | [P2YEAR] - [CYEAR] | 9996. [P2YEAR] - [CYEAR], DK Which Year | 9997. Before [P2YEAR], DK Exact Year | DK/RF |
| GO TO J27CKPT | | | GO TO J27CKPT | |

↓

J7MO. [CYAQRTH], [CYNAMF CYNAML], age: [AGEIWDAT]E

LOOP 1 & NO SP IN FU: In what month and year did [R=HEAD: you / R=OFUM, PROXY: [HEAD]] last get married?

LOOP 1 & SP IN FU: In what month and year did [R=HEAD: you and your spouse (last) get married / R=SPOUSE: you and [HEAD] get married / R=PARTNER, OFUM, PROXY: [HEAD] and his spouse (last) get married]?

LOOP 2: Please tell me again, in what month and year did [R=HEAD & SPOUSE IN FU: you and your spouse get married / R=HEAD & PARTNER IN FU: [PARTNER] and her spouse (last) get married / R=SPOUSE: you and your spouse get married / R=PARTNER: you and your spouse (last) get married / R=OFUM, PROXY: [SPOUSE] and her spouse (last) get married]?

- SELECT Month and [Enter] to go to next screen for year
- IF NECESSARY: What would be your best estimate?

| | | | | | |
|------------|-------------|--------------|-------------|--------------|--------------|
| 1. January | 2. February | 3. March | 4. April | 5. May | 6. June |
| 7. July | 8. August | 9. September | 10. October | 11. November | 12. December |
| 21. Winter | 22. Spring | 23. Summer | 24. Fall | | |

J7YR. [CYAQRTH], [CYNAMF CYNAML], age: [AGEIWDATE]

The month entered is: [J7MO]

- ENTER the year below

1901- [CYEAR] Actual year

9996 [P2YEAR]-[CYEAR], DK which year

9997 Before [P2YEAR], DK exact year

| | | | | |
|-----------------|--------------------|--|---|-------|
| 1901 - [P3YEAR] | [P2YEAR] - [CYEAR] | 9996. [P2YEAR] - [CYEAR], DK Which Year | 9997. Before [P2YEAR], DK Exact Year | DK/RF |
|-----------------|--------------------|--|---|-------|

GO TO J27CKPT



GO TO J27CKPT

J8. [CYAQRTH], [CYNAMF CYNAML], age: [AGEIWDATE]

What (was/is) [your / [HEAD / SP]'s] spouse's name?

- ACCEPT any name-do not probe.

String 25

J9. [CYAQRTH], [CYNAMF CYNAML], age: [AGEIWDATE]

Before that, [were you / was [he / she]] widowed, divorced, or had [you / he / she] never been married?

| | | | | |
|------------------|------------|-----------------------------------|--|-------|
| 2. Never married | 3. Widowed | 4. Divorced, marriage annulled | 7. Other-specify (J9SPEC. Specify (STRING 100)) | DK/RF |
|------------------|------------|-----------------------------------|--|-------|

GO TO J27CKPT



GO TO J11MO

GO TO J12MO

J10MO. [CYAQRTH], [CYNAMF CYNAML], age: [AGEIWDATE]

In what month and year [were you / was [he / she]] widowed?

- SELECT Month and [Enter] to go to next screen for year
- IF NECESSARY: What would be your best estimate?

| | | | |
|--------------|-------------|--------------|--------------|
| 1. January | 2. February | 3. March | 4. April |
| 5. May | 6. June | 7. July | 8. August |
| 9. September | 10. October | 11. November | 12. December |
| 21. Winter | 22. Spring | 23. Summer | 24. Fall |

J10YR. [CYAQRTH], [CYNAMF CYNAML], age: [AGEIWDATE]

The month entered is: [J10MO]

- ENTER the year below

1901- [CYEAR] Actual year

9996 [P2YEAR]-[CYEAR], DK which year

9997 Before [P2YEAR], DK exact year

| | | | |
|-----------------|--------------------|---|--------------------------------------|
| 1901 - [P3YEAR] | [P2YEAR] - [CYEAR] | 9996. [P2YEAR] - [CYEAR], DK Which Year | 9997. Before [P2YEAR], DK Exact Year |
|-----------------|--------------------|---|--------------------------------------|

GO TO J27CKPT

J11MO. [CYAQRTH], [CYNAMF CYNAML], age: [AGEIWDATE]

In what month and year did [your / [HEAD / SP]'s] (divorce/annulment) become final?

- SELECT Month and [Enter] to go to next screen for year
- IF NECESSARY: What would be your best estimate?

| | | | | |
|--------------|--------------|------------|--------------|-------------|
| 1. January | 2. February | 3. March | 4. April | 5. May |
| 6. June | 7. July | 8. August | 9. September | 10. October |
| 11. November | 12. December | 21. Winter | 22. Spring | 23. Summer |
| | | | | 24. Fall |

J11YR. [CYAQRTH], [CYNAMF CYNAML], age: [AGEIWDATE]

The month entered is: [J11MO]

- ENTER the year below

1901- [CYEAR] Actual year

9996 [P2YEAR]-[CYEAR], DK which year

9997 Before [P2YEAR], DK exact year

| | | |
|-----------------|--------------------|---|
| 1901 - [P3YEAR] | [P2YEAR] - [CYEAR] | 9996. [P2YEAR] - [CYEAR], DK Which Year |
|-----------------|--------------------|---|

| |
|--------------------------------------|
| 9997. Before [P2YEAR], DK Exact Year |
|--------------------------------------|

J12MO. [CYAQRTH], [CYNAMF CYNAML], age: [AGEIWDATE]

In what month and year did [you / they] stop living together?

- SELECT Month and [Enter] to go to next screen for year
- IF NECESSARY: What would be your best estimate?

| | | | | | |
|--------------|--------------|------------|--------------|-------------|----------|
| 1. January | 2. February | 3. March | 4. April | 5. May | |
| 6. June | 7. July | 8. August | 9. September | 10. October | |
| 11. November | 12. December | 21. Winter | 22. Spring | 23. Summer | 24. Fall |

J12YR. [CYAQRTH], [CYNAMF CYNAML], age: [AGEIWDATE]

The month entered is: [J12MO]

- ENTER the year below

1901- [CYEAR] Actual year

9996 [P2YEAR]-[CYEAR], DK which year

9997 Before [P2YEAR], DK exact year

| | | |
|-----------------|--------------------|---|
| 1901 - [P3YEAR] | [P2YEAR] - [CYEAR] | 9996. [P2YEAR] - [CYEAR], DK Which Year |
|-----------------|--------------------|---|

| |
|--------------------------------------|
| 9997. Before [P2YEAR], DK Exact Year |
|--------------------------------------|

GO TO J27CKPT

END J4_J12

J12A. AQS of FU Member

J13CKPT. CAI Checkpoint: (For Type C (J1CKPT=6, 7, 9, 11, 12, 14)); Marital Status

| | | |
|------------------------------|-----------------|---------------|
| 1. Never Married (Marital=2) | → GO TO J27CKPT | 5. All Others |
| ↓ | | |

SECTION_J[1-24].J14_J26 [1-24]=AQS of FU Member

J14. [CYAQRTH], [CYNAMF CYNAML], age: [AGEIWDATE]

[HEAD OR SP LOOP: (Now) I'd like to ask about [your / [HEAD / SP]'s] family history. / 1st OFUM LOOP: Now let's talk about the other members of the family. / ALL OTHERS: (Now let's talk about the other members of the family.)]

Altogether, how many times [have you / has [HEAD / SP / OFUM] been married?

| | | | | |
|---|---------------|--------|-------|---------------|
| 1 | → GO TO J21MO | 2 - 15 | DK/RF | → GO TO J21MO |
|---|---------------|--------|-------|---------------|

↓

J15MO. [CYAQRTH], [CYNAMF CYNAML], age: [AGEIWDATE]

In what month and year did [you / he / she] get married for the first time?

- SELECT Month and [Enter] to go to next screen for year
- IF NECESSARY: What would be your best estimate?

| | | | | | |
|------------|-------------|--------------|-------------|--------------|--------------|
| 1. January | 2. February | 3. March | 4. April | 5. May | 6. June |
| 7. July | 8. August | 9. September | 10. October | 11. November | 12. December |
| 21. Winter | 22. Spring | 23. Summer | 24. Fall | | |

J15YR. [CYAQRTH], [CYNAMF CYNAML], age: [AGEIWDATE]

The month entered is: [J15MO]

- ENTER the year below

1901-[CYEAR] Actual year

9996 [P2YEAR]-[CYEAR], DK which year

9997 Before [P2YEAR], DK exact year

| | | | |
|-----------------|--------------------|--|---|
| 1901 - [P3YEAR] | [P2YEAR] - [CYEAR] | 9996. [P2YEAR] - [CYEAR], DK Which Year | 9997. Before [P2YEAR], DK Exact Year |
|-----------------|--------------------|--|---|

J16. [CYAQRTH], [CYNAMF CYNAML], age: [AGEIWDATE]

What was [your / his / her] first spouse's name?

- ACCEPT any name-do not probe

String 25

J17. [CYAQRTH], [CYNAMF CYNAML], age: [AGEIWDATE]

Did that marriage end in widowhood, divorce, or what?

| | | | |
|--------------|-------------------------------|--|-------|
| 3. Widowhood | 4. Divorce, marriage annulled | 7. Other-specify (J17SPEC. Specify (STRING 100)) | DK/RF |
|--------------|-------------------------------|--|-------|

↓

GO TO J19MO

GO TO J20MO

J18MO. [CYAQRTH], [CYNAMF CYNAML], age: [AGEIWDATE]

In what month and year [were you / was [he / she]] widowed?

- SELECT Month and [Enter] to go to next screen for year
- IF NECESSARY: What would be your best estimate?

| | | | | | |
|------------|-------------|--------------|-------------|--------------|--------------|
| 1. January | 2. February | 3. March | 4. April | 5. May | 6. June |
| 7. July | 8. August | 9. September | 10. October | 11. November | 12. December |
| 21. Winter | 22. Spring | 23. Summer | 24. Fall | | |

J18YR. [CYAQRTH], [CYNAMF CYNAML], age: [AGEIWDATE]

The month entered is: [J18MO]

- ENTER the year below

1901- [CYEAR] Actual year

9996 [P2YEAR]-[CYEAR], DK which year

9997 Before [P2YEAR], DK exact year

| | | | |
|-----------------|--------------------|--|---|
| 1901 - [P3YEAR] | [P2YEAR] - [CYEAR] | 9996. [P2YEAR] - [CYEAR], DK Which Year | 9997. Before [P2YEAR], DK Exact Year |
|-----------------|--------------------|--|---|

GO TO J21MO

J19MO. [CYAQRTH], [CYNAMF CYNAML], age: [AGEIWDATE]

In what month and year did [your / his / her] (divorce / annulment) become final?

- SELECT Month and [Enter] to go to next screen for year
- IF NECESSARY: What would be your best estimate?

| | | | | | |
|------------|-------------|--------------|-------------|--------------|--------------|
| 1. January | 2. February | 3. March | 4. April | 5. May | 6. June |
| 7. July | 8. August | 9. September | 10. October | 11. November | 12. December |
| 21. Winter | 22. Spring | 23. Summer | 24. Fall | | |

J19YR. [CYAQRTH], [CYNAMF CYNAML], age: [AGEIWDATE]

The month entered is: [J19MO]

- ENTER the year below

1901- [CYEAR] Actual year

9996 [P2YEAR]-[CYEAR], DK which year

9997 Before [P2YEAR], DK exact year

| | | | |
|-----------------|--------------------|--|---|
| 1901 - [P3YEAR] | [P2YEAR] - [CYEAR] | 9996. [P2YEAR] - [CYEAR], DK Which Year | 9997. Before [P2YEAR], DK Exact Year |
|-----------------|--------------------|--|---|

J20MO. [CYAQRTH], [CYNAMF CYNAML], age: [AGEIWDATE]

In what month and year did you stop living together?

- SELECT Month and [Enter] to go to next screen for year
- IF NECESSARY: What would be your best estimate?

| | | | | | |
|------------|-------------|--------------|-------------|--------------|--------------|
| 1. January | 2. February | 3. March | 4. April | 5. May | 6. June |
| 7. July | 8. August | 9. September | 10. October | 11. November | 12. December |
| 21. Winter | 22. Spring | 23. Summer | 24. Fall | | |

J20YR. [CYAQRTH], [CYNAMF CYNAML], age: [AGEIWDATE]

The month entered is: [J20MO]

- ENTER the year below

1901- [CYEAR] Actual year

9996 [P2YEAR]-[CYEAR], DK which year

9997 Before [P2YEAR], DK exact year

| | | | |
|-----------------|--------------------|--|---|
| 1901 - [P3YEAR] | [P2YEAR] - [CYEAR] | 9996. [P2YEAR] - [CYEAR], DK Which Year | 9997. Before [P2YEAR], DK Exact Year |
|-----------------|--------------------|--|---|

J21MO. [CYAQRTH], [CYNAMF CYNAML], age: [AGEIWDATE]

In what month and year did [you / he / she] (last) get married?

- SELECT Month and [Enter] to go to next screen for year
- IF NECESSARY: What would be your best estimate?

| | | | | | |
|------------|-------------|--------------|-------------|--------------|--------------|
| 1. January | 2. February | 3. March | 4. April | 5. May | 6. June |
| 7. July | 8. August | 9. September | 10. October | 11. November | 12. December |
| 21. Winter | 22. Spring | 23. Summer | 24. Fall | | |

J21YR. [CYAQRTH], [CYNAMF CYNAML], age: [AGEIWDATE]

The month entered is: [J21MO]

- ENTER the year below

1901- [CYEAR] Actual year

9996 [P2YEAR]-[CYEAR], DK which year

9997 Before [P2YEAR], DK exact year

| | | | |
|-----------------|--------------------|--|---|
| 1901 - [P3YEAR] | [P2YEAR] - [CYEAR] | 9996. [P2YEAR] - [CYEAR], DK Which Year | 9997. Before [P2YEAR], DK Exact Year |
|-----------------|--------------------|--|---|

J22. [CYAQRTH], [CYNAMF CYNAML], age: [AGEIWDATE]

What (was / is) [your / his / her] spouse's name?

- ACCEPT any name-do not probe

String 25

J23CKPT. CAI Checkpoint: (For Type C (J1CKPT=6, 7, 9, 11, 12, 14)); Marital Status

| | | | |
|---------------------------|---|----------------------------|--|
| 1. Widowed (Marital=3) | 2. Separated (Marital=5); or Married Partner (Marital=1) | 3. Divorced (Marital=4) | 4. Married Head, Spouse, OFUM (Marital=1) |
| ↓ | GO TO J26MO | GO TO J25MO | GO TO J27CKPT |

J24MO. [CYAQRTH], [CYNAMF CYNAML], age: [AGEIWDATE]

In what month and year [were you / was [he / she]] widowed?

- SELECT Month and [Enter] to go to next screen for year
- IF NECESSARY: What would be your best estimate?

| | | | | | |
|------------|-------------|--------------|-------------|--------------|--------------|
| 1. January | 2. February | 3. March | 4. April | 5. May | 6. June |
| 7. July | 8. August | 9. September | 10. October | 11. November | 12. December |
| 21. Winter | 22. Spring | 23. Summer | 24. Fall | | |

J24YR. [CYAQRTH], [CYNAMF CYNAML], age: [AGEIWDATE]

The month entered is: [J24MO]

- ENTER the year below

1901- [CYEAR] Actual year

9996 [P2YEAR]-[CYEAR], DK which year

9997 Before [P2YEAR], DK exact year

| | | | |
|-----------------|--------------------|--|---|
| 1901 - [P3YEAR] | [P2YEAR] - [CYEAR] | 9996. [P2YEAR] - [CYEAR], DK Which Year | 9997. Before [P2YEAR], DK Exact Year |
|-----------------|--------------------|--|---|

GO TO J27CKPT

J25MO. [CYAQRTH], [CYNAMF CYNAML], age: [AGEIWDATE]

In what month and year did [your / his / her] (divorce / annulment) become final?

- SELECT Month and [Enter] to go to next screen for year
- IF NECESSARY: What would be your best estimate?

| | | | | | |
|------------|-------------|--------------|-------------|--------------|--------------|
| 1. January | 2. February | 3. March | 4. April | 5. May | 6. June |
| 7. July | 8. August | 9. September | 10. October | 11. November | 12. December |
| 21. Winter | 22. Spring | 23. Summer | 24. Fall | | |

J25YR. [CYAQRTH], [CYNAMF CYNAML], age: [AGEIWDATE]

The month entered is: [J25MO]

- ENTER the year below

1901- [CYEAR] Actual year

9996 [P2YEAR]-[CYEAR], DK which year

9997 Before [P2YEAR], DK exact year

| | | | |
|-----------------|--------------------|--|---|
| 1901 - [P3YEAR] | [P2YEAR] - [CYEAR] | 9996. [P2YEAR] - [CYEAR], DK Which Year | 9997. Before [P2YEAR], DK Exact Year |
|-----------------|--------------------|--|---|

J26MO. [CYAQRTH], [CYNAMF CYNAML], age: [AGEIWDATE]

In what month and year did you stop living together?

- SELECT Month and [Enter] to go to next screen for year
- IF NECESSARY: What would be your best estimate?

| | | | | | |
|------------|-------------|--------------|-------------|--------------|--------------|
| 1. January | 2. February | 3. March | 4. April | 5. May | 6. June |
| 7. July | 8. August | 9. September | 10. October | 11. November | 12. December |
| 21. Winter | 22. Spring | 23. Summer | 24. Fall | | |

J26YR. [CYAQRTH], [CYNAMF CYNAML], age: [AGEIWDATE]

The month entered is: [J26MO]

- ENTER the year below

1901- [CYEAR] Actual year

9996 [P2YEAR]-[CYEAR], DK which year

9997 Before [P2YEAR], DK exact year

| | | | |
|-----------------|--------------------|--|---|
| 1901 - [P3YEAR] | [P2YEAR] - [CYEAR] | 9996. [P2YEAR] - [CYEAR], DK Which Year | 9997. Before [P2YEAR], DK Exact Year |
|-----------------|--------------------|--|---|

END J14_J26

J27CKPT. CAI Checkpoint: J1Ckpt

| | | | |
|----------------------|-------------------------|--|-------------|
| 1. Type A (J1CKPT=1) | 2. Type B (J1CKPT=3, 4) | 3. Type C (J1CKPT=6, 7, 9, 11, 12, 14) | → GO TO J30 |
| ↓ | | | |

J28. [CYAQRTH], [CYNAMF CYNAML], age: [AGEIWDATE]

[1st ITERATION: We are updating the information we collected in [P2YEAR].]

TYPE A: Have [you and [HEAD / SP] / [HEAD] and [SP]] had any children since [REINT & PYIWDATE=RESPONSE: our last interview on [PYIWDATE] / SO; or REINT & PYIWDATE=NA: January [P2YEAR]]?

TYPE B: [CNTOTHKIDS>0: Including [your / his / her] [child / children] ([CNTOTHKIDS]) we already spoke about, [have you / has [HEAD / SP]] / ALL OTHERS: [Have you / Has [HEAD / SP]] [J2 is MALE: fathered / J2 is FEMALE: given birth to] any children since [REINT & PYIWDATE=RESPONSE: our last interview on [PYIWDATE] / SO; or REINT & PYIWDATE=NA: January [P2YEAR]]?

- DO NOT count stillbirths, stepchildren, or adopted children
- [FUMI FU MEMBERS AGE<=2: IWER: FU child(ren) born since [P2YEAR]: [CYNAME, AGEIWDATE, CYAQRTH, CYFUHU]]

1. Yes 5. No → GO TO J32CKPT

↓

J29. [CYAQRTH], [CYNAMF CYNAML], age: [AGEIWDATE]

How many is that? (Since [our last interview on [PYIWDATE] / January [P2YEAR]]?)

- [CNTOTHKIDS>0: If needed: Including [your / his / her] [child / children] ([CNTOTHKIDS]) we already spoke about
- [FUMI FU MEMBERS AGE<=2: IWER: FU child(ren) born since [P2YEAR]: [CYNAME, AGEIWDATE, CYAQRTH, CYFUHU]]

1 - 20 → GO TO OTHKID RULE DK/RF GO TO J32CKPT

J30. [CYAQRTH], [CYNAMF CYNAML], age: [AGEIWDATE]

[Now let's talk about the other members of the family. / (Now, we would like to ask about births of children.)]

[CNTOTHKIDS>0: Including [your / his / her] [child / children] ([CNTOTHKIDS]) we already spoke about, how / ALL OTHERS: How] many children [have you / has [HEAD / SP / OFUM]] [J2 is MALE: ever fathered / J2 is FEMALE: [yourself] ever given birth to]?

- DO NOT count stillbirths, stepchildren, or adopted children
- [FU MEMBERS AGE<=2 & CYFUHU=FUMI: IWER: FU child(ren) born since [P2YEAR]: CYNAMF CYNAML, AGEIWDATE, CYAQRTH, CYFUHU]

0 → GO TO J32CKPT 1 - 20 DK/RF → GO TO J32CKPT

↓

OTHKID Rule: J1Ckpt; Number of Children for Whom This Person Previously Reported as Other Birth Parent

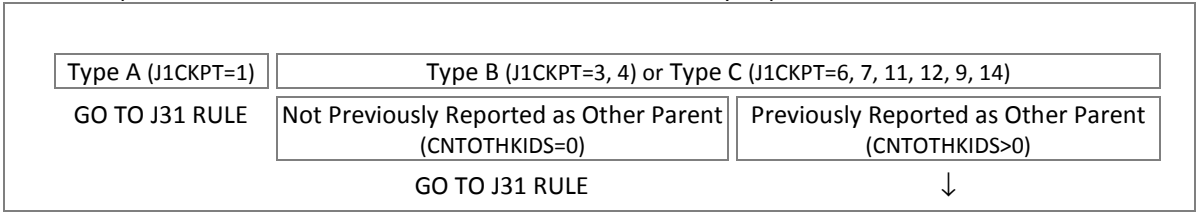

SECTION_J[1-24].OTHKIDTABLE.OTHKIDBLOCK[1-10] [1-24]=AQSN of FU Member; [1-10]=Which child previously reported

OTHKID. [CYNAMF CYNAML], [CYAQRTH], age: [AGEIWDATE]

IWER: VERIFY each child already reported for [CYNAMF]: Before we go on, I'd like to confirm [your / [HEAD / SP / OFUM]'s] [CNTOTHKIDS=1: child / CNTOTHKIDS>1: children] we already spoke about:

([First / Next], how about) [J31] ([J31NAML])? ([J31] was reported as [your / [HEAD / SP / OFUM]'s] child, is that right?)

- ENTER [1] if Child verified as [[CYNAMF CYNAML]'s] child
[NAME] [DOB] [PARENT NAME]

1. Yes 5. No

END OTHKIDBLOCK

J31 Rule: Number of Remaining Children (#Children Reported at J29/J30 minus #Children Reported as OTHKID=Yes)

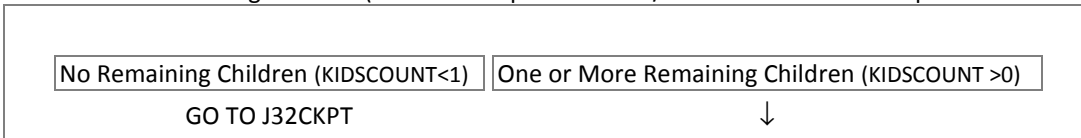

SECTION_J[1-24].J31NAME[1-20] [1-24]=AQSN of FU Member; [1-20]=Which child NOT previously reported

J31. Child of: [CYAQRTH], [CYNAMF CYNAML], age: [AGEIWDATE]

[LOOP 1: Now let's talk about [your / [HEAD / SP / OFUM]'s] [OTHKID=YES: other] [CNTJ31KIDS=1: child / CNTJ31KIDS>1: children] / ALL OTHERS: (Now let's talk about [your / [HEAD / SP / OFUM]'s] [other] [child / children])].

What is [this / the [first / next]] child's name [, including middle and last names / (, including middle and last names)]?

- ENTER First Name
- Ctrl-D and Ctrl-R not allowed; For DK/RF, type [DK] or [RF]

String 25

J31NAMM. Child of: [CYAQRTH], [CYNAMF CYNAML], age: [AGEIWDATE]

(What is [this / the [first / next]] child's name, including middle and last names?)

- ENTER Middle Name
- Ask for Middle Name but do not probe DK or RF
- If none, PRESS [Enter] to continue
- Ctrl-D and Ctrl-R not allowed; For DK/RF, PRESS [Enter] to continue

String 25

J31NAML. Child of: [CYAQRTH], [CYNAMF CYNAML], age: [AGEIWDATE]

(What is [this / the [first / next]] child's name, including middle and last names?)

- ENTER Last Name
- Ctrl-D and Ctrl-R not allowed; For DK/RF, type [DK] or [RF]

String 25

OTHPARENTCKPT. CAI Checkpoint: J1Ckpt

1. Type A (J1CKPT=1) → GO TO DADAQSN 5. Type B (J1CKPT=3, 4) or Type C (J1CKPT=6, 7, 11, 12, 9, 14)



OTHPARENT. [J31] Child of: [CYAQRTH], [CYNAMF CYNAML], age: [AGEIWDATE]

Who is [J31]'s birth [J2 IS MALE: mother / J2 IS FEMALE: father]?

- Verify with earlier report from family listing info [F3]
- ENTER [96] if birth parent is not listed and R **cannot or will not** report the parent's name
- ENTER [97] if birth parent is not listed and R **can** report the parent's name

1-24. [CYNAMF] [CYNAML], [[ID68], [PN],] [CYAQRTH], [CYFUHU], DOB: [CYBMO/CYBDY/CYBYR], AGE: [AGEIWDATE] *AQSN list of FU Members age 12+ and opposite gender*

31-50. [OTHPARENTNAMF OTHPARENTNAML] (Other birth parent of [J31]) *List of OthParent=97 for previous children*

51-60. Name unknown (Other birth parent of [J31]) *List of OthParent=96 for previous children*

61-70. Donated sperm/egg or surrogate of [J31] *List of OthParent=95 for previous children*

95. Donated sperm/egg; Surrogate

96. Other person-DK or RF name DK/RF 97. Other person-specify name

ASSIGN DADAQSN/MOMAQSN; GO TO OS1 RULE



SECTION_J[1-24].J31NAME[1-20].PARENTNOTINFU [1-24]=AQSN of FU Member; [1-20]=Which child

OTHPARENTNAMF. Other birth parent of: [J31] (Child of [CYAQRTH], [CYNAMF CYNAML])

What is [her / his] name (first and last names)?

- ENTER Birth [Mother's / Father's] First Name
- ENTER names only; do not ENTER [DK, RF, UNKNOWN, etc.]
- If R **cannot or will not** report parent's name, GO BACK and ENTER [96] at OTHPARENT (other birth parent)

String 25

OTHPARENTNAML. Other birth parent of: [J31] (Child of [CYAQRTH], [CYNAMF CYNAML])

(What is [her / his] name (first and last names)?)

- ENTER Birth [Mother's / Father's] First Name
- ENTER names only; do not ENTER [DK, RF, UNKNOWN, etc.]
- If R **cannot or will not** report parent's name, GO BACK and ENTER [96] at OTHPARENT (other birth parent)

String 25

END PARENTNOTINFU

DADAQSN. AQSN of Child's Birth Father (J2; or 1-24 if OTHPARENT=1-24; or Null if OTHPARENT=31-97, DK/RF)

MOMAQSN. AQSN of Child's Birth Mother (J2; or 1-24 if OTHPARENT=1-24; or Null if OTHPARENT=31-97, DK/RF)

OS1 Rule: Whether More Children at J29 or J30

More Children → Repeat J31-MomAQSN; Max=20; No More Children

Then GO TO OS1



END J31NAME

SECTION_J[1-24].OS1_OS9[1-20] [1-24]=AQSN of FU Member; [1-20]=Which child

OS1. [J31] Child of: [CYAQRTH], [CYNAMF CYNAML], age: [AGEIWDATE]

(Now) Let's talk about [J31]. (We can't always tell from a name. Is that a male or a female?)

| | |
|---------|-----------|
| 1. Male | 2. Female |
|---------|-----------|

OS2MO. [J31] Child of: [CYAQRTH], [CYNAMF CYNAML], age: [AGEIWDATE]

What is [J31]'s full birthdate?

- SELECT Month
- IF NECESSARY: What would be your best estimate?

| | | | | | |
|------------|-------------|--------------|-------------|--------------|--------------|
| 1. January | 2. February | 3. March | 4. April | 5. May | 6. June |
| 7. July | 8. August | 9. September | 10. October | 11. November | 12. December |
| 21. Winter | 22. Spring | 23. Summer | 24. Fall | | |

OS2DY. [J31] Child of: [CYAQRTH], [CYNAMF CYNAML], age: [AGEIWDATE]

(What is [J31]'s full birthdate?)

The month entered is: [OS2MO]

- ENTER day

| |
|--------|
| 1 - 31 |
|--------|

OS2YR. [J31] Child of: [CYAQRTH], [CYNAMF CYNAML], age: [AGEIWDATE]

The month entered is: [OS2MO]

(What is [J31]'s full birthdate?)

- ENTER the year below

1901- [CYEAR] Actual year

9996 [P2YEAR]-[CYEAR], DK which year

9997 Before [P2YEAR], DK exact year

| | | | | |
|-----------------|--------------------|--|---|-------|
| 1901 - [P3YEAR] | [P2YEAR] - [CYEAR] | 9996. [P2YEAR] - [CYEAR], DK Which Year | 9997. Before [P2YEAR], DK Exact Year | DK/RF |
| GO TO OS4TOWN | | | GO TO OS4TOWN | |

↓

*SIGNAL FOR J28=YES & OS2YR<P2YEAR-CYEAR or 9997*Years prior to [P2YEAR] are not allowed since we are asking about children born since [PYIWDATE]. Please VERIFY child's year of birth.*About Newborn*

OS3LBS. [J31] Child of: [CYAQRTH], [CYNAMF CYNAML], age: [AGEIWDATE]

How much did [he / she] weigh at birth?

- ENTER weight in POUNDS and OUNCES
- Or PRESS [Enter] to go to next screen for kilograms

| | | | | |
|---------|-----------------|--------|-------|--------------|
| [ENTER] | → GO TO OS3KILO | 0 - 20 | DK/RF | → GO TO OS3A |
|---------|-----------------|--------|-------|--------------|

↓

OS3OZ. [J31] Child of: [CYAQRTH], [CYNAMF CYNAML], age: [AGEIWDATE]

- The weight in pounds entered is: [OS3LBS]

- ENTER the OUNCES

| |
|--------|
| 0 - 15 |
|--------|

GO TO OS10A

OS3KILO. [J31] Child of: [CYAQRTH], [CYNAMF CYNAML], age: [AGEIWDATE]

(How much did [he / she] weigh at birth?)

- ENTER weight in [KILOGRAMS](#)

→ GO TO OS10A



OS3A. [J31] Child of: [CYAQRTH], [CYNAMF CYNAML], age: [AGEIWDATE]

Did [he / she] weigh more than 5-1/2 pounds (2500 grams) or less than 5-1/2 pounds (2500 grams), or what?



GO TO OS10A

OS3B. [J31] Child of: [CYAQRTH], [CYNAMF CYNAML], age: [AGEIWDATE]

Did [he / she] weigh more than 9 pounds (4100 grams) or less than 9 pounds (4100 grams), or what?

OS10A. [J31] Child of: [CYAQRTH], [CYNAMF CYNAML], age: [AGEIWDATE]

What was [his / her] length at birth?

- ENTER length in [INCHES](#)
- Or PRESS [Enter] to go to next screen for centimeters

→ GO TO OS10B → GO TO OS10C



OS10CENT. [J31] Child of: [CYAQRTH], [CYNAMF CYNAML], age: [AGEIWDATE]

(What was [his / her] length at birth?)

- ENTER length in [CENTIMETERS](#)

→ GO TO OS10C



OS10B. [J31] Child of: [CYAQRTH], [CYNAMF CYNAML], age: [AGEIWDATE]

INTERVIEWER: Did R indicate that the length of the baby was an estimate?

OS10C. [J31] Child of: [CYAQRTH], [CYNAMF CYNAML], age: [AGEIWDATE]

Did [MOMAQSN=RESPAQSN: you / OTHPARENT=1-50, 97: [MOTHER] / OTHPARENT=95, 96, DK/RF: [J31]'s mother] breastfeed [J31] at all?

- ENTER [1] for any amount of breastfeeding by R
- ENTER [1] if R only expressed or pumped breastmilk to be fed to the baby
- ENTER [1] if R is still breastfeeding this child

OS4TOWN. [J31 NAME] Child of: [CYAQRTH], [CYNAMF CYNAML], age: [AGEIWDATE]

Where was [he / she] ([J31]) born?

- ENTER Town and go to next screen for State
- For Don't Know, ENTER [Ctrl D]
- For Refusal, ENTER [Ctrl R]

OS4STATE. [J31 NAME] Child of: [CYAQRTH], [CYNAMF CYNAML], age: [AGEIWDATE]

What is the State?

[OS4TOWN]

- Start typing the name of the State to bring up the look-up list
- For foreign country birth, ENTER [FOR] to select "Foreign Country" from the state list

String 30; U.S State → GO TO OS5 Foreign Country DK/RF → GO TO OS5



OS4COUNTRY. [J31 NAME] Child of: [CYAQRTH], [CYNAMF CYNAML], age: [AGEIWDATE]

What is the Country?

[OS4TOWN], [OS4STATE]

- Start typing the name of the Foreign Country to bring up the look-up list

String 25; Country

OS5. [J31 NAME] Child of: [CYAQRTH], [CYNAMF CYNAML], age: [AGEIWDATE]

Is [J31] living with [you / [HEAD / SP / OFUM]] now, away with [his / her] [J2 IS FEMALE: father / J2 IS MALE: mother], with some other relative, (has [he/she] set up a separate household), or what?

- If R says "adopted out", PROBE: Was that to a relative or to a non-relative?

| | |
|---|--|
| 1. Living in FU now | 7. Other-specify (OS5SPEC. Specify (STRING 100)) |
| 2. Living with father elsewhere | 8. Adopted out to relative |
| 3. Living with mother elsewhere | 9. Adopted out to non-relative |
| 4. Living with other relative elsewhere | 10. Adopted out; don't know/refused to whom |
| 5. Set up a separate household | 6. Deceased |
| | 11. Fostered out |
| | DK/RF |

GO TO OS7



GO TO OS7

OS6MO. [J31] Child of: [CYAQRTH], [CYNAMF CYNAML], age: [AGEIWDATE]

In what month and year did [he / she] die?

- SELECT Month and [Enter] to go to next screen for year
- IF NECESSARY: What would be your best estimate?

| | | | | | |
|------------|-------------|--------------|-------------|--------------|--------------|
| 1. January | 2. February | 3. March | 4. April | 5. May | 6. June |
| 7. July | 8. August | 9. September | 10. October | 11. November | 12. December |
| 21. Winter | 22. Spring | 23. Summer | 24. Fall | | |

OS6YR. [J31] Child of: [CYAQRTH], [CYNAMF CYNAML], age: [AGEIWDATE]

The month entered is: [OS6MO]

- ENTER the year below
- 1901- [CYEAR] Actual year
 9996 [P2YEAR]-[CYEAR], DK which year
 9997 Before [P2YEAR], DK exact year

| | | | |
|-----------------|--------------------|--|---|
| 1901 - [P3YEAR] | [P2YEAR] - [CYEAR] | 9996. [P2YEAR] - [CYEAR], DK Which Year | 9997. Before [P2YEAR], DK Exact Year |
|-----------------|--------------------|--|---|

GO TO OS8 RULE

OS7. [J31] Child of: [CYAQRTH], [CYNAMF CYNAML], age: [AGEIWDATE]

Is [he / she] Spanish, Hispanic, or Latino? That is, Mexican, Mexican American, Chicano, Puerto Rican, Cuban, or other Spanish?

| | | | |
|-------------------------|------------|--|------------|
| 0. Not Spanish/Hispanic | 1. Mexican | 2. Mexican American | 3. Chicano |
| 4. Puerto Rican | 5. Cuban | 7. Other-specify (OS7SPEC. Specify (STRING 100)) | |

OS8. [J31] Child of: [CYAQRTH], [CYNAMF CYNAML], age: [AGEIWDATE]

What is [his / her] race? Is [he / she] white, black, American Indian, Alaska Native, Asian, Native Hawaiian, or Pacific Islander?

- ENTER all that apply
- PROBE: Any others?

| | | | |
|--|--------------------------------------|---------------------|----------|
| 1. White | 2. Black, African-American, or Negro | | |
| 3. American Indian or Alaska Native | 5. Native Hawaiian | 6. Pacific Islander | |
| 7. Other-specify (OS8SPEC. Specify (STRING 100)) | | DK/RF | 4. Asian |

GO TO OS8 RULE



OS8A. [J31] Child of: [CYAQRTH], [CYNAMF CYNAML], age: [AGEIWDATE]

Would that be Chinese, Filipino, Asian Indian, or what?

| | | | | | |
|---|-------------|-----------------|-------------|-----------|---------------|
| 1. Chinese | 2. Filipino | 3. Asian Indian | 4. Japanese | 5. Korean | 6. Vietnamese |
| 7. Other Asian-specify (OS8ASPEC. Specify (STRING 100)) | | | | | |

OS8 Rule: Whether More Children at J29 or J30

| | | |
|---------------|--|------------------|
| More Children | → Repeat J31-OS8; Max=20; Then GO TO OS71CKPT | No More Children |
| | | ↓ |

OS10CKPT. CAI Checkpoint: Whether Child Is Newborn & Not Adopted Out

| | |
|--|---------------|
| 1. Newborn, Not Adopted Out - REINT, SO & OS5<>8, 9, 10 & (J1CKPT=TYPE A, B1, B2 & (OS2MO/DY/YR>PYIWDATE or OS2YR=9996)) or (J1CKPT=TYPEC1 & (OS2YR=P2YEAR-CYEAR, 9996)) - RECON, RECSO, IMMIG & J1CKPT=TYPEC2 & OS5<>8, 9, 10 & OS2YR=P2YEAR-CYEAR, 9996 | 5. All Others |
|--|---------------|

OS71CKPT. CAI Checkpoint: Whether Multiple Newborns Not Adopted Out & Have Same Birthdate +/- 1 Day

| | | | | | |
|---|---------------|----------------|----------------|---------------|------------------|
| Multiple Newborns, Not Adopted Out & Same Birthdate | | | | 8. All Others | → GO TO OS11CKPT |
| 1. Twins | 2. Triplets | 3. Quadruplets | 4. Quintuplets | | |
| 5. Sextuplets | 6. Septuplets | 7. Octuplets | | | |
| | | | | | ↓ |

END OS1_OS9

SECTION_J[1-24].MULTIPLE[1-10] [1-24]=AQSN of FU Member; [1-10]=Which multiple birth

OS71. Child [1-8]: [J31], DOB: [OS2BMO/OS2BDY/OS2BYR]

Is it correct that [J31] [and [J31]...] are [twins / triplets / quadruplets / quintuplets / sextuplets / septuplets / octuplets]?

1. Yes 5. No → GO TO OS11CKPT



OS72. Child [1-8]: [J31], DOB: [OS2BMO/OS2BDY/OS2BYR]

Are they identical [twins / triplets / quadruplets / quintuplets / sextuplets / septuplets / octuplets] or are they fraternal [twins / triplets / quadruplets / quintuplets / sextuplets / septuplets / octuplets]?

- IF [twins / triplets / quadruplets / quintuplets / sextuplets / septuplets / octuplets] are not the same sex, they are fraternal

1. Identical 2. Fraternal DK/RF → GO TO OS74



OS73. Child [1-8]: [J31], DOB: [OS2BMO/OS2BDY/OS2BYR]

How do you know they are [identical / fraternal] [twins / triplets / quadruplets / quintuplets / sextuplets / septuplets / octuplets]?

- ENTER all that apply
- PROBE: Any others?

| | |
|--|---|
| 1. Cheek swab DNA test | 2. Blood DNA test |
| 3. Placental membrane DNA test | 4. Blood typing test |
| 5. Observation of placenta | 6. Doctor/midwife told me |
| 7. Completed a questionnaire | 8. Someone else not present at delivery told me |
| [OS72=FRATERNAL: 9. Newborns of different gender] | |
| 97. Other-specify (OS73SPEC. Please specify. (String 100)) | |

OS74. Child [1-8]: [J31], DOB: [OS2BMO/OS2BDY/OS2BYR]

Are they often mistaken for each other, or are they different enough to tell apart?

1. Often mistaken for one another 2. Different enough to tell apart

END MULTIPLE**SECTION_J[1-24].NEWBORNNOTADP[1-10]** [1-24]=AQSN of FU Member; [1-10]=Which birth

OS11CKPT. CAI Checkpoint: Whether Newborn is Single or Multiple Birth

1. Single Birth; or 1st Newborn of Multiple Birth 5. Other Newborn of Multiple Birth → GO TO OS28CKPT

OS AQSN. AQSN of FU Member

DADAQSN. AQSN of Child's Birth Father

MOMAQSN. AQSN of Child's Birth Mother

OS11_1CKPT. CAI Checkpoint: Whether R is Parent of Newborn

1. R=Parent (RESPAQSN=MOMAQSN or DADAQSN) → GO TO OS11 5. All Others



OS11_1. [J31] [Child / Children] of: [CYAQRTH], [CYNAMF CYNAML], age: [AGEIWDATE]

Next are some questions about [MOMAQSN=RESPAQSN: your / OTHPARENT=1-50, 97: [MOTHER]'s / OTHPARENT=51-70, 95, 96, DK/RF: [J31]'s mother] pregnancy and the birth of [[J31] / the [twins / triplets / quadruplets / quintuplets / sextuplets / septuplets / octuplets]].

Would you be able to answer these questions?

1. Yes 5. No DK/RF

↓ GO TO OS64 RULE

OS11. [J31] [Child / Children] of: [CYAQRTH], [CYNAMF CYNAML], age: [AGEIWDATE]

How many weeks pregnant [MOMAQSN=RESPAQSN: were you / OTHPARENT=1-50, 97: was [MOTHER] / OTHPARENT=51-70, 95, 96, DK/RF: was [J31]'s [and [J31]'s...] mother] when [you / she] learned that [you were / she was] pregnant with [J31] [and [J31]'s...]?

- ENTER number of weeks
- Weeks of pregnancy should be counted as completed weeks since the last normal menstrual period.

→ GO TO OS13 DK/RF

↓

OS12. [J31] [Child / Children] of: [CYAQRTH], [CYNAMF CYNAML], age: [AGEIWDATE]

Was it less than three months, more than three months, or what?

1. Less than 3 months 2. More than 3 months 3. About 3 months DK/RF

GO TO OS13

↓

GO TO OS13

OS12A. [J31] [Child / Children] of: [CYAQRTH], [CYNAMF CYNAML], age: [AGEIWDATE]

Was it less than six months, more than six months, or what?

1. Less than 6 months 2. More than 6 months 3. About 6 months

OS13. [J31] [Child / Children] of: [CYAQRTH], [CYNAMF CYNAML], age: [AGEIWDATE]

In the 6 months before [you / [MOTHER] / [J31]'s [and [J31]'s...] mother] found out [you were / she was] pregnant (with [J31] [and [J31]'s...]), how many cigarettes did [you / she] smoke a day, on average?

- DEFINITION: A standard pack of American cigarettes contains 20 cigarettes

→ GO TO OS16 DK/RF → GO TO OS16

↓

OS14. [J31] [Child / Children] of: [CYAQRTH], [CYNAMF CYNAML], age: [AGEIWDATE]

After before [you / [MOTHER] / [J31]'s [and [J31]'s...] mother] found out [you were / she was] pregnant this time (with [J31] [and [J31]'s...]), did [you / she] smoke cigarettes at all during the pregnancy?

1. Yes 5. No → GO TO OS16

↓

OS15. [J31] [Child / Children] of: [CYAQRTH], [CYNAMF CYNAML], age: [AGEIWDATE]

On average, how many cigarettes before [you / [MOTHER] / [J31]'s [and [J31]'s...] mother] smoke per day after [you / she] found out that [you were / she was] pregnant this time (with [J31] [and [J31]'s...])?

- DEFINITION: A standard pack of American cigarettes contains 20 cigarettes

OS16. [J31] [Child / Children] of: [CYAQRTH], [CYNAMF CYNAML], age: [AGEIWDATE]

Did before [you / [MOTHER] / [J31]'s [and [J31]'s...] mother] drink any alcoholic beverages, including beer, wine, or liquor, during the 12 months before [J31] [and [J31]...] [was / were] born?

1. Yes 5. No → GO TO OS19



OS17. [J31] [Child / Children] of: [CYAQRTH], [CYNAMF CYNAML], age: [AGEIWDATE]

During [your / that] pregnancy, on average, how often did [you / she] have any alcohol to drink? Would you say: never, less than once a month, about once a month, several times a month, about once a week, several times a week, or every day?

| | | |
|--------------------------|---------------------------|-------------------------|
| 1. Never | 2. Less than once a month | 3. About once a month |
| 4. Several times a month | 5. About once a week | 6. Several times a week |
| | | 7. Every day |

OS19. [J31] [Child / Children] of: [CYAQRTH], [CYNAMF CYNAML], age: [AGEIWDATE]

Was a cesarean delivery done?

- IF NECESSARY, PROBE: (Was/Were) [J31] [and [J31]...] delivered by an incision in before [your / [MOTHER]'s / [J31]'s [and [J31]'s...] mother's] abdomen?

1. Yes 5. No → GO TO OS23Months



OS20. [J31] [Child / Children] of: [CYAQRTH], [CYNAMF CYNAML], age: [AGEIWDATE]

Was this [your / [MOTHER]'s / [J31]'s [and [J31]'s...] mother's] first cesarean delivery, or did [you / she] have one before?

1. Yes, first cesarean 5. No, had cesarean before

OS23Months. [J31] [Child / Children] of: [CYAQRTH], [CYNAMF CYNAML], age: [AGEIWDATE]

How many months or weeks had [you / [MOTHER] / [J31]'s [and [J31]'s...] mother] been pregnant when [J31] [and [J31]...] [was / were] born?

- ENTER number of months here and number of weeks on next screen
- ENTER [0] if R reports number of weeks only
- PROBE for an exact number; Fill fields for both months and weeks as R reports them. For example:
 "2 1/2 months" should be entered as 2 months and 2 weeks
 "9 months" would be entered as 9 months and 0 weeks.
 "40 weeks" would be entered as 0 months and 40 weeks

0 - 10 DK/RF → GO TO OS24



OS23Weeks. [J31] [Child / Children] of: [CYAQRTH], [CYNAMF CYNAML], age: [AGEIWDATE]

(How many months or weeks had [you / [MOTHER] / [J31]'s [and [J31]'s...] mother] been pregnant when [J31] [and [J31]...] [was / were] born?)

- ENTER number of weeks
- ENTER [0] for None
- PROBE for an exact number; Fill fields for both months and weeks as R reports them. For example:
 "2 1/2 months" should be entered as 2 months and 2 weeks
 "9 months" would be entered as 9 months and 0 weeks.
 "40 weeks" would be entered as 0 months and 40 weeks

0 - 44 → GO TO OS27 DK/RF → GO TO OS24

SIGNAL for OS23MONTHS+OS23WEEKS <6 MOS/24 WKS OR >10 MOS/44 WKS (& RESPONSE):

R has reported a [*<6 MOS/24 WKS: live birth occurring earlier than 24 weeks or 6 months of pregnancy / >10 MOS/44 WKS: pregnancy longer than 44 weeks or 10 months*]. This is extremely unlikely. Please correct the months or weeks of gestation, if necessary. If you suppress this check, please enter an F2 comment for the reason.

OS24. [J31] [Child / Children] of: [CYAQRTH], [CYNAMF CYNAML], age: [AGEIWDATE]

A preterm delivery is one that occurs at 36 weeks or earlier in pregnancy. As far as you know, did [you / [MOTHER] / [J31]'s [and [J31]'s...] mother] have a preterm delivery?

1. Yes 5. No

OS27. [J31] [Child / Children] of: [CYAQRTH], [CYNAMF CYNAML], age: [AGEIWDATE]

When [J31] [and [J31]...] [was / were] born, how was the delivery bill paid?

- ENTER all that apply
- PROBE: Any other ways?
- IF needed: We would like to know whether the delivery bill was paid through employer provided health insurance, private health insurance, a government program like Medicare or Medicaid, out of pocket, or what?
- IF R mentions government plan: Is that Medicare, Medi-gap, Medicaid or a state program, military provided such as Tricare, ChampUS or ChampVA, Indian health insurance, or some other plan?
- IF needed (if Affordable Care Act/Obamacare/Health Insurance Exchanges mentioned): Was that a privately purchased health insurance plan or Medicaid/[STATEMEDPROG]/[SCHIPNAME]?
- If R says "bill still unpaid", ASK: How do you think that bill will be paid?
- Do not include costs of prenatal care, only costs of the delivery and any follow-up care.

| | |
|--|---|
| 1. Employer provided health insurance (Current or former employer) | 2. Private health insurance purchased |
| 5. Medicaid/[STATEMEDPROG]/[SCHIPNAME] | 6. Military Health Care/Tricare (Active duty) |
| 7. TRICARE/CHAMPUS/CHAMP-VA (Dependents, Veterans) | 8. Indian Health Insurance |
| 11. Veterans Administration (VA) | 12. Out-of-pocket |
| 13. No payment required (IF VOL) | |
| 97. Other-specify (OS27SPEC. Specify (String 100)) | |

OS28CKPT. CAI Checkpoint: Whether Newborn Living or Deceased

| | | |
|----------------------------|-----------------------------|-------------------|
| 1. Newborn Living (OS5<>6) | 5. Newborn Deceased (OS5=6) | → GO TO OS33 RULE |
| ↓ | | |

SECTION_J[1-24].NEWBORNNOTADP[1-10].OS28B32[1-8] [1-24]=AQSN of FU Member; [1-10]=Which birth; [1-8]=Which child

OS28. [J31] Child of: [CYAQRTH], [CYNAMF CYNAML], age: [AGEIWDATE]

[(And)] How many days did [J31] stay in the hospital?

- ENTER number of days
- ENTER [994] if baby still in hospital
- ENTER [995] if less than 1 day (less than 24 hours)
- ENTER [996] if baby not born in a hospital
- ENTER [997] if baby did not stay in hospital

| | | | | |
|---------|---------------------------------|-----------------------|-------|---------------------------------------|
| 1 - 150 | 994. Still in hospital (IF VOL) | 995. < 1 day (IF VOL) | DK/RF | 996. Not born in hospital (IF VOL) |
| | | | | 997. Didn't stay in hospital (IF VOL) |

↓

GO TO OS40 RULE

OS30. [J31] Child of: [CYAQRTH], [CYNAMF CYNAML], age: [AGEIWDATE]

Did [J31] receive any newborn care in an intensive care unit, premature nursery, or any other type of special care facility?

1. Yes 5. No → GO TO OS40 RULE



OS31. [J31] Child of: [CYAQRTH], [CYNAMF CYNAML], age: [AGEIWDATE]

How many days did [J31] stay in this special care facility after birth?

- ENTER number of days

1 - 150 994. Baby still in special care facility

OS32. [J31] Child of: [CYAQRTH], [CYNAMF CYNAML], age: [AGEIWDATE]

Did [J31] require assisted ventilation for more than 30 minutes?

1. Yes 5. No → GO TO OS40 RULE



OS33. [J31] Child of: [CYAQRTH], [CYNAMF CYNAML], age: [AGEIWDATE]

How many days did [J31] require ventilation?

- ENTER number of days

1 - 150

OS33 Rule: Whether Newborn is Single or Multiple Birth

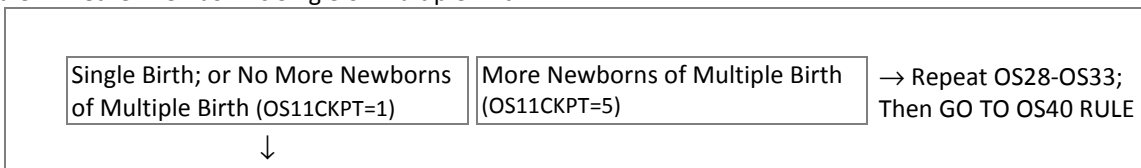

END OS28B32

OS40 Rule: Whether Newborn is Single or Multiple Birth

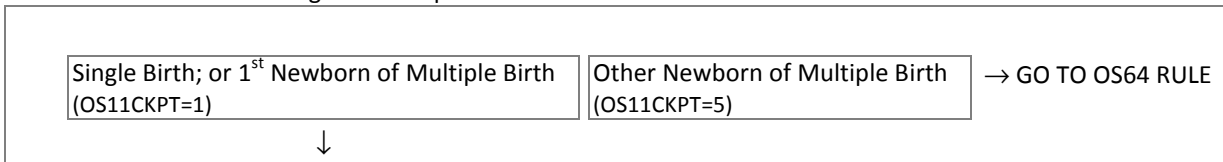

OS40. [J31] [Child / Children] of: [CYAQRTH], [CYNAMF CYNAML], age: [AGEIWDATE]

When [you were / [MOTHER] was / [J31]'s [and [J31]'s...] mother was], did [you / she] ever visit a doctor or other medical care provider for prenatal care, that is, for one or more pregnancy check-ups?

- Include visits to a midwife or birthing center

1. Yes 5. No → GO TO OS51



OS41. [J31] [Child / Children] of: [CYAQRTH], [CYNAMF CYNAML], age: [AGEIWDATE]

How many weeks pregnant [were you / was [MOTHER] / was [J31]'s [and [J31]'s...] mother] at the time of [your / her] first prenatal care visit?

- ENTER number of weeks completed since the last normal menstrual period
- Weeks of pregnancy should be counted as completed weeks since the last normal menstrual period.
- Include visits to a midwife or birthing center

1 - 40 → GO TO OS43 DK/RF



OS42. [J31] [Child / Children] of: [CYAQRTH], [CYNAMF CYNAML], age: [AGEIWDAT]E

Was it less than three months, more than three months, or what?

| | | | |
|-----------------------|-----------------------|-------------------|-------|
| 1. Less than 3 months | 2. More than 3 months | 3. About 3 months | DK/RF |
|-----------------------|-----------------------|-------------------|-------|

GO TO OS43



GO TO OS43

OS42A. [J31] [Child / Children] of: [CYAQRTH], [CYNAMF CYNAML], age: [AGEIWDAT]E

Was it less than six months, more than six months, or what?

| | | |
|-----------------------|-----------------------|-------------------|
| 1. Less than 6 months | 2. More than 6 months | 3. About 6 months |
|-----------------------|-----------------------|-------------------|

OS43. [J31] [Child / Children] of: [CYAQRTH], [CYNAMF CYNAML], age: [AGEIWDAT]E

How many visits to a doctor or other medical care provider for prenatal care did [you / [MOTHER] / [J31]'s [and [J31]'s...] mother] have when [you were / she was] pregnant (with [J31] [and [J31]...])?

- ENTER number of prenatal care visits
- Do not include visits for WIC (Women, Infants, and Children nutritional program)
- Include visits to a midwife or birthing center

1 - 94

OS47. [J31] [Child / Children] of: [CYAQRTH], [CYNAMF CYNAML], age: [AGEIWDAT]E

Where did [you / [MOTHER] / [J31]'s [and [J31]'s...] mother] go [OS43<>1: most of the time] for [your / her] prenatal [OS43=1: visit / ALL OTHERS: visits] with a doctor or other medical care provider?

- Do not include visits for WIC (Women, Infants, and Children nutritional program)
- Include visits to a midwife or birthing center

| | | |
|----------------------------|---------------------------|----------------------------|
| 1. Clinic or health center | 2. Doctor's office or HMO | 3. Hospital emergency room |
|----------------------------|---------------------------|----------------------------|

| | | |
|-----------------------------------|----------------------------|---------------------|
| 4. Hospital outpatient department | 5. Midwife/birthing center | 6. Some other place |
|-----------------------------------|----------------------------|---------------------|

| |
|--------------------------------------|
| 7. Didn't go to one place most often |
|--------------------------------------|

OS48. [J31] [Child / Children] of: [CYAQRTH], [CYNAMF CYNAML], age: [AGEIWDAT]E

How was [your / [MOTHER]'s / [J31]'s [and [J31]'s...] mother's] prenatal care paid for?

- ENTER all that apply
- PROBE: Any other ways?
- IF needed: We would like to know whether the prenatal care was paid through employer provided health insurance, private health insurance, a government program like Medicare or Medicaid, out of pocket, or what?
- IF R mentions government plan: Is that Medicare, Medi-gap, Medicaid or a state program, military provided such as Tricare, ChampUS or ChampVA, Indian health insurance, or some other plan?
- IF needed: Was it employer-provided health insurance, private health insurance, Medicaid or a state program, military provided such as Tricare, ChampUS or ChampVA, Indian health insurance, Veterans Administration, some other plan, or out-of-pocket?
- IF needed (if Affordable Care Act/Obamacare/Health Insurance Exchanges mentioned): Was that a privately purchased health insurance plan or Medicaid/[STATEMEDPROG]/[SCHIPNAME]?
- If R says "bill still unpaid", ASK: How do you think that bill will be paid?

| | |
|--|---------------------------------------|
| 1. Employer provided health insurance (Current or former employer) | 2. Private health insurance purchased |
|--|---------------------------------------|

| | |
|--|---|
| 5. Medicaid/[STATEMEDPROG]/[SCHIPNAME] | 6. Military Health Care/Tricare (Active duty) |
|--|---|

| | |
|--|----------------------------|
| 7. TRICARE/CHAMPUS/CHAMP-VA (Dependents, Veterans) | 8. Indian Health Insurance |
|--|----------------------------|

| | |
|----------------------------------|-------------------|
| 11. Veterans Administration (VA) | 12. Out-of-pocket |
|----------------------------------|-------------------|

| |
|----------------------------------|
| 13. No payment required (IF VOL) |
|----------------------------------|

| |
|--|
| 97. Other-specify (OS48SPEC. Specify (String 100)) |
|--|

OS51. [J31] [Child / Children] of: [CYAQRTH], [CYNAMF CYNAML], age: [AGEIWDATE]

What was [your / [MOTHER]'s / [J31]'s [and [J31]'s...] mother's] weight just before [you / she] delivered?

- ENTER weight in POUNDS
- Or PRESS [Enter] to continue to next screen for kilograms
- If more than 400 pounds, ENTER [400]

[ENTER] 100 - 400 DK/RF
↓
GO TO OS52

OS51KILO. [J31] [Child / Children] of: [CYAQRTH], [CYNAMF CYNAML], age: [AGEIWDATE]

(What was [your / [MOTHER]'s / [J31]'s [and [J31]'s...] mother's] weight just before [you / she] delivered?)

- ENTER weight in KILOGRAMS
- If more than 180 kilograms, ENTER [180]

36.0 - 180.0

OS52. [J31] [Child / Children] of: [CYAQRTH], [CYNAMF CYNAML], age: [AGEIWDATE]

What was [your / [MOTHER]'s / [J31]'s [and [J31]'s...] mother's] weight just before [you / she] became pregnant (with [J31] [and [J31]'s...])?

- ENTER weight in POUNDS
- Or PRESS [Enter] to continue to next screen for kilograms
- If more than 400 pounds, ENTER [400]

[ENTER] 100 - 400 DK/RF
↓
GO TO OS53CKPT

OS52KILO. [J31] [Child / Children] of: [CYAQRTH], [CYNAMF CYNAML], age: [AGEIWDATE]

(What was [your / [MOTHER]'s / [J31]'s [and [J31]'s...] mother's] weight just before [you / she] became pregnant (with [J31] [and [J31]'s...])?)

- ENTER weight in KILOGRAMS
- If more than 180 kilograms, ENTER [180]

36.0 - 180.0

OS53CKPT. CAI Checkpoint: Whether Weight Loss, Gain, or No Change (1 LB=0.45 KG; 1 KG=2.2 LB)

| | | | |
|----------------|----------------|--------------|---------------|
| 1. Weight Loss | 2. Weight Gain | 3. No Change | 5. All Others |
| ↓ | ↓ | ↓ | GO TO OS56 |

OS53. [J31] [Child / Children] of: [CYAQRTH], [CYNAMF CYNAML], age: [AGEIWDATE]

Does that mean that [you / she] lost [[OS52] minus [OS51]] pounds ([[OS52KILO] minus [OS51KILO]] kilograms) during [your / her] pregnancy?

- IF necessary, verify weights and go back to correct
- Weight before delivery: [OS51] pounds ([OS51KILO] kilograms)
- Weight before pregnancy: [OS52] pounds ([OS52KILO] kilograms)

1. Yes 5. No
GO TO OS58CKPT

OS54. [J31] [Child / Children] of: [CYAQRTH], [CYNAMF CYNAML], age: [AGEIWDATE]

Does that mean that [you / she] gained [[OS51] minus [OS52]] pounds ([[OS51KILO] minus [OS52KILO]] kilograms) during [your / her] pregnancy?

- IF necessary, verify weights and go back to correct
- Weight before delivery: [OS51] pounds ([OS51KILO] kilograms)
- Weight before pregnancy: [OS52] pounds ([OS52KILO] kilograms)

1. Yes 5. No
GO TO OS58CKPT

OS55. [J31] [Child / Children] of: [CYAQRTH], [CYNAMF CYNAML], age: [AGEIWDATE]

Does that mean that [you / she] did not gain or lose any weight during [your / her] pregnancy?

- IF necessary, verify weights and go back to correct
- Weight before delivery: [OS51] pounds ([OS51KILO] kilograms)
- Weight before pregnancy: [OS52] pounds ([OS52KILO] kilograms)

1. Yes 5. No
GO TO OS58CKPT

OS56. [J31 NEWBORN(s)] [Child / Children] of: [CYAQRTH], [CYNAMF CYNAML], age: [AGEIWDAT]E

Did [you / [MOTHER] / [J31]'s [and [J31]'s...] mother] gain or lose weight during [your / her] pregnancy (with [J31] [and [J31]...])?

1. Gained weight 2. Lost weight 3. Did not gain or lose any weight DK/RF



GO TO OS58CKPT

OS57. [J31] [Child / Children] of: [CYAQRTH], [CYNAMF CYNAML], age: [AGEIWDAT]E

How much weight did [you / she] [OS56=GAINED: gain / OS56=LOST: lose]?

- ENTER weight in POUNDS
- Or PRESS [Enter] to continue to next screen for kilograms

[ENTER] 1-900 DK/RF



GO TO OS58CKPT

OS57KILO. [J31 NAME(s)] [Child / Children] of: [CYAQRTH], [CYNAMF CYNAML], age: [AGEIWDAT]E

(How much weight did [you / she] [gain / lose]?)

- ENTER number of KILOGRAMS

0.5 - 408.2

OS58CKPT. CAI Checkpoint: Whether R Is Parent of Newborn

1. R=Parent (RESPAQSN=MOMASQSN or DADAQSN) 5. All Others → GO TO OS64 RULE



About Birth Mother

OS58. [J31] [Child / Children] of: [CYAQRTH], [CYNAMF CYNAML], age: [AGEIWDAT]E

Just before [you / [MOTHER] / [J31]'s [and [J31]'s...] mother] became pregnant with [J31] [and [J31]...], did [you / she] use any methods to keep from getting pregnant?

- Methods to keep from getting pregnant include abstinence, withdrawal, rhythm, natural family planning methods, and the pill.
- See [F1] help screen listing many possible birth control methods. Read methods to respondent only as necessary.

1. Yes 5. No 7. Never used any methods to prevent pregnancy (IF VOL) → GO TO OS60CKPT DK/RF



OS59. [J31] [Child / Children] of: [CYAQRTH], [CYNAMF CYNAML], age: [AGEIWDAT]E

Had [you / [MOTHER] / [J31]'s [and [J31]'s...] mother] stopped all methods before [you / she] became pregnant?

1. Yes 5. No 7. Never used any methods to prevent pregnancy (IF VOL)

OS60CKPT. CAI Checkpoint: Whether Mother Did Not Use or Stopped Contraception Before Pregnancy

1. Stopped Contraception ((OS58=Yes & OS59=Yes) or (OS58=No, DK/RF & OS59=Yes, No, DK/RF)) 5. All Others



GO TO OS35

About Birth Mother

OS60. [J31] [Child / Children] of: [CYAQRTH], [CYNAMF CYNAML], age: [AGEIWDATE]

Was the reason [you / [MOTHER] / [J31]'s [and [J31]'s...] mother] [OS59=YES: stopped / ALL OTHERS: [were / was] not] using any methods because [you / [MOTHER] / [J31]'s [and [J31]'s...] mother] wanted to become pregnant?

1. Yes 5. No

About R & Other Birth Parent

OS35. [J31] [Child / Children] of: [CYAQRTH], [CYNAMF CYNAML], age: [AGEIWDATE]

Did you or [OTHPARENT=1-24: [FATHER] / OTHPARENT=95, 96, DK/RF: [J31]'s [and [J31]'s...] father / OTHPARENT=1-50, 97: [MOTHER] / OTHPARENT=51-70, 95, 96, DK/RF: [J31]'s [and [J31]'s...] mother] ever go to a doctor or other medical care provider to talk about ways to help [you / her] become pregnant with [J31] [and [J31]...]?

1. Yes 5. No

OS62CKPT. CAI Checkpoint: Whether R Is Mother of Newborn

| | | |
|--------------------------------|---------------|------------------|
| 1. R=Mother (RESPAQSN=MOMAQSN) | 5. All Others | → GO TO OS63CKPT |
| ↓ | | |

About Birth Mother if R=Birth Mother

OS62. [J31] [Child / Children] of: [CYAQRTH], [CYNAMF CYNAML], age: [AGEIWDATE]

Just before you became pregnant (with [J31] [and [J31]...]), did you yourself want to have a baby?

1. Yes → GO TO OS63CKPT 5. No DK/RF → GO TO OS63CKPT

↓

OS62A. [J31] [Child / Children] of: [CYAQRTH], [CYNAMF CYNAML], age: [AGEIWDATE]

Did you want a baby but not at that time, or did you want none or no more at all?

1. Not at that time 2. None or no more at all 3. Didn't matter (IF VOL)

GO TO OS63CKPT

OS63CKPT. CAI Checkpoint: Whether R is Father of Newborn

| | | |
|--------------------------------|---------------|--------------------------|
| 1. R=Father (RESPAQSN=DADAQSN) | 5. All Others | → GO TO NEWBORN END RULE |
| ↓ | | |

About Birth Father if R=Birth Father

OS63. [J31] [Child / Children] of: [CYAQRTH], [CYNAMF CYNAML], age: [AGEIWDATE]

Just before [OTHPARENT=1-50, 97: [MOTHER] / OTHPARENT=51-70, 95, 96, DK/RF: [J31]'s [and [J31]'s...] mother]] became pregnant (with [J31] [and [J31]...]), did you want to have a child?

1. Yes → GO TO NEWBORN END RULE 5. No DK/RF → GO TO NEWBORN END RULE

↓

OS63A. [J31] [Child / Children] of: [CYAQRTH], [CYNAMF CYNAML], age: [AGEIWDATE]

Did you want to have a child but not at that time, or did you want to have none or no more at all?

1. Not at that time 2. None or no more at all 3. Didn't matter (IF VOL)

NEWBORN END Rule: Whether More Children at J31

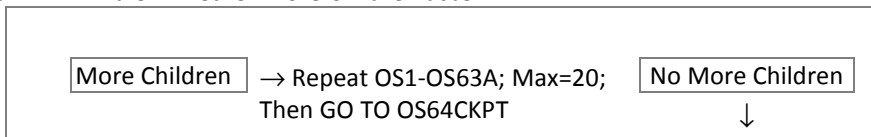

END NEWBORNNOTADP

OS64CKPT. CAI Checkpoint: Whether R is Parent of Any Newborn

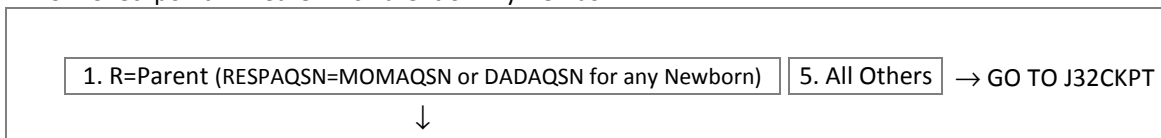

SECTION_J[1-24].PREGINTENTION [1-24]=AQSN of FU Member

About R

OS64. [CYAQRTH], [CYNAMF CYNAML], age: [AGEIWDATE]

Looking to the future, do you yourself want another [R=MOTHER: baby / R=FATHER: child] at some time?

- **IF needed:** Other than your children already born

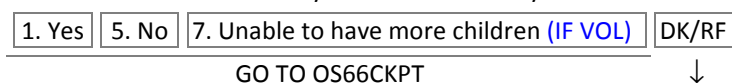

OS65. [CYAQRTH], [CYNAMF CYNAML], age: [AGEIWDATE]

Do you think you probably want or probably do not want to have another [R=MOTHER: baby / R=FATHER: child] at some time in the future?

- **If R insists:** Don't know/not sure

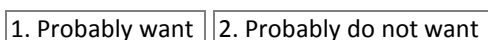

OS66CKPT. CAI Checkpoint: Whether R Has Spouse/Partner/Boyfriend/Girlfriend in FU, or R=Married OFUM

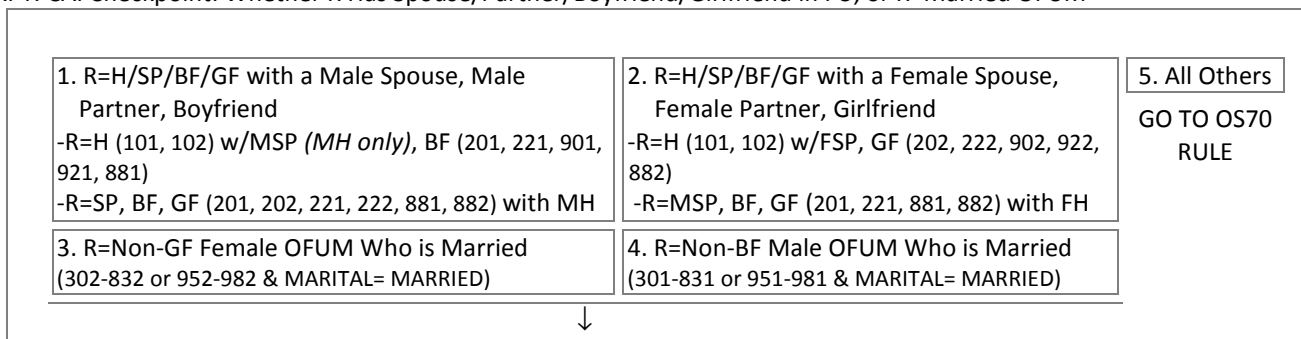

About R's SP, BF, GF

OS66. [CYAQRTH], [CYNAMF CYNAML], age: [AGEIWDATE]

Looking to the future, does [R=HEAD, SP, BF, GF: [[CYNAMF] ([CYNAML])] / R=ALL OTHER OFUMs: your spouse] want a [OS66CKPT=1, 3: child / OS66CKPT=2, 4: baby] or another [child / baby] at some time? Would you say definitely yes, probably yes, probably no or definitely no?



OS70 Rule: Whether Parent (and SP/BF/GF) Want More Children

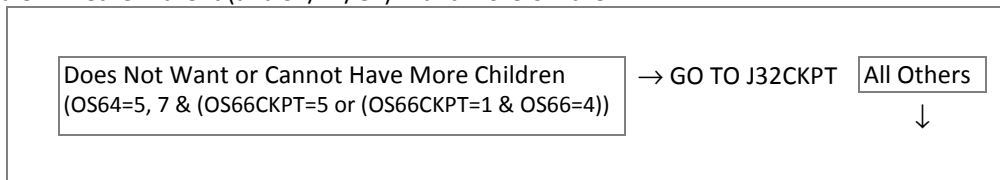

About R (and SP/BF/GF)

OS70. [CYAQRTH], [CYNAMF CYNAML], age: [AGEIWDATE]

Sometimes what people want and what they intend are different because they are not able to do what they want.

The next question is about your [R=HEAD, SP, BF, GF: and [CYNAMF] ([CYNAML])'s / R=ALL OTHER OFUMs: and your spouse's] intentions for a [R=MOTHER: baby / R=FATHER: child] in the future.

Altogether, how many more [babies / children] do you [and [CYNAMF] ([CYNAML]) / and your spouse] intend to have?

- ENTER number of [babies / children]
- ENTER [95] for "None"
- Do not probe DK
- Includes current pregnancy
- Does not include intended adoptions or stepchildren
- If needed: "Intend" refers to what you [and [CYNAMF] ([CYNAML]) / and your spouse] are actually going to try to do

1 - 94 | 95. None

END PREGINTENTION

END NEWBORNNOTADP

J32CKPT. CAI Checkpoint: J1Ckpt



J33. [CYAQRTH], [CYNAMF CYNAML], age: [AGEIWDATE]

TYPE A

[Have you or [HEAD / Has [HEAD] or [SP]] legally adopted any children since January [P2YEAR]?

TYPE B

[Has [HEAD / SP]] legally adopted any children since January [P2YEAR]?

1. Yes | 5. No → GO TO J1 END RULE

↓

J34. [CYAQRTH], [CYNAMF CYNAML], age: [AGEIWDATE]

[Have you / Has [HEAD / SP]] ever legally adopted any children?

1. Yes | 5. No → GO TO J1 END RULE

↓

J35. [CYAQRTH], [CYNAMF CYNAML], age: [AGEIWDATE]

[TYPE A, B: How many is that? / TYPE C: How many altogether?]

1 - 20

SECTION_J[1-24].J36NAME[1-20] [1-24]=AQSN of FU Member; [1-20]=Which child

J36. Child of: [CYAQRTH], [CYNAMF CYNAML], age: [AGEIWDATE]

What is the [first / next] child's name, including middle and last names?

- ENTER First Name
- Ctrl-D and Ctrl-R not allowed; For DK/RF, type [DK] or [RF]

J36NAMM. Child of: [CYAQRTH], [CYNAMF CYNAML], age: [AGEIWDATE]

(What is the [first / next] child's name, including middle and last names?)

- ENTER Middle Name
- Ask for Middle Name but do not probe DK or RF
- If none, PRESS [Enter] to continue
- Ctrl-D and Ctrl-R not allowed; For DK/RF, PRESS [Enter] to continue

J36NAML. Child of: [CYAQRTH], [CYNAMF CYNAML], age: [AGEIWDATE]

(What is the [first / next] child's name, including middle and last names?)

- ENTER Last Name
- Ctrl-D and Ctrl-R not allowed; For DK/RF, type [DK] or [RF]

AS1 Rule: Number of Children at J35

| | | |
|--|---|---|
| <input type="button" value="More Children"/> | → Repeat J36-J36NAML; Max=20; Then GO TO AS1 | <input type="button" value="No More Children"/> |
| | | ↓ |

END J36NAME**SECTION_J[1-24].AS1_AS9[1-15]** [1-24]=AQSN of FU Member; [1-15]=Which child

AS1. [J36 NAME] Child of: [CYAQRTH], [CYNAMF CYNAML], age: [AGEIWDATE]

Let's talk about [J36]. (We can't always tell from a name. Is that a male or a female?)

AS2MO. [J36] Child of: [CYAQRTH], [CYNAMF CYNAML], age: [AGEIWDATE]

What is [J36]'s full birthdate?

- SELECT Month
- IF NECESSARY: What would be your best estimate?

| | | | | | |
|------------|-------------|--------------|-------------|--------------|--------------|
| 1. January | 2. February | 3. March | 4. April | 5. May | 6. June |
| 7. July | 8. August | 9. September | 10. October | 11. November | 12. December |
| 21. Winter | 22. Spring | 23. Summer | 24. Fall | | |

AS2DY. [J36] Child of: [CYAQRTH], [CYNAMF CYNAML], age: [AGEIWDATE]

(What is [J36]'s full birthdate?)

The month entered is: [AS2MO]

- ENTER day

AS2YR. [J36] Child of: [CYAQRTH], [CYNAMF CYNAML], age: [AGEIWDATE]

The month entered is: [AS2MO]

(What is [J36]'s full birthdate?)

- ENTER the year below

1901- [CYEAR] Actual year

9996 [P2YEAR]-[CYEAR], DK which year

9997 Before [P2YEAR], DK exact year

| | | | |
|-----------------|--------------------|--|---|
| 1901 - [P3YEAR] | [P2YEAR] - [CYEAR] | 9996. [P2YEAR] - [CYEAR], DK Which Year | 9997. Before [P2YEAR], DK Exact Year |
|-----------------|--------------------|--|---|

AS3. [J36] Child of: [CYAQRTH], [CYNAMF CYNAML], age: [AGEIWDATE]

What was [his / her] relationship to [TYPE A: [you and [HEAD / SP] / [HEAD] and [SP]] / TYPE B, C: [you / [HEAD / SP]]] before the adoption?

| | | | |
|---|--------------------------|---|-----------------------|
| 96. None | | | |
| 301. Son | 302. Daughter | 331. Stepson | 332. Stepdaughter |
| 381. Foster son | 382. Foster daughter | 401. Brother | 402. Sister |
| 471. Brother-in-law | 472. Sister-in-law | 481. Brother of Partner/Boyfriend/Girlfriend | |
| 482. Sister of Partner/Boyfriend/Girlfriend | | 601. Grandson | 602. Granddaughter |
| 651. Great-grandson | 652. Great-granddaughter | 701. Nephew of Head | 702. Niece of Head |
| 711. Nephew of Spouse | 712. Niece of Spouse | 740. Cousin of Head | 750. Cousin of Spouse |
| 831. Son of Boyfriend/Girlfriend | | 832. Daughter of Boyfriend/Girlfriend | |
| 950. Relative of Head | 960. Relative of Spouse | 970. Relative of Partner/Boyfriend/Girlfriend | |

AS4TOWN. [J36] Child of: [CYAQRTH], [CYNAMF CYNAML], age: [AGEIWDATE]

Where was [he / she] born?

- ENTER Town and go to next screen for State
- For Don't Know, ENTER [Ctrl D]
- For Refusal, ENTER [Ctrl R]

String 25

AS4STATE. [J36] Child of: [CYAQRTH], [CYNAMF CYNAML], age: [AGEIWDATE]

What is the State?

[AS4TOWN]

- Start typing the name of the State to bring up the look-up list
- For foreign country birth, ENTER [FOR] to select "Foreign Country" from the state list State

String 30; U.S State → GO TO AS5 Foreign Country DK/RF → GO TO AS5



AS4COUNTRY. [J36] Child of: [CYAQRTH], [CYNAMF CYNAML], age: [AGEIWDATE]

What is the Country?

[AS4TOWN], [AS4STATE]

- Start typing the name of the Foreign Country to bring up the look-up list

String 25; Country

AS5. [J36] Child of: [CYAQRTH], [CYNAMF CYNAML], age: [AGEIWDATE]

Is [J36] living with you now, away with [his / her] [J2 IS FEMALE: father / J2 IS MALE: mother], with some other relative, (has he/she set up a separate household), or what?

| | | |
|--|---|-------------|
| 1. Living in FU now | 2. Living with father elsewhere | |
| 3. Living with mother elsewhere | 4. Living with other relative elsewhere | |
| 5. Set up a separate household | | 6. Deceased |
| 7. Other-specify (AS5SPEC. Specify (STRING 100)) | DK/RF | ↓ |

GO TO AS7

AS6MO. [J36] Child of: [CYAQRTH], [CYNAMF CYNAML], age: [AGEIWDATE]

In what month and year did [he / she] die?

- SELECT Month and [Enter] to go to next screen for year
- IF NECESSARY: What would be your best estimate?

| | | | | | |
|------------|-------------|--------------|-------------|--------------|--------------|
| 1. January | 2. February | 3. March | 4. April | 5. May | 6. June |
| 7. July | 8. August | 9. September | 10. October | 11. November | 12. December |
| 21. Winter | 22. Spring | 23. Summer | 24. Fall | | |

AS6YR. [J36] Child of: [CYAQRTH], [CYNAMF CYNAML], age: [AGEIWDATE]

The month entered is: [AS6MO]

- ENTER the year below
- 1901- [CYEAR] Actual year
 9996 [P2YEAR]-[CYEAR], DK which year
 9997 Before [P2YEAR], DK exact year

| | | | |
|-----------------|--------------------|--|---|
| 1901 - [P3YEAR] | [P2YEAR] - [CYEAR] | 9996. [P2YEAR] - [CYEAR], DK Which Year | 9997. Before [P2YEAR], DK Exact Year |
|-----------------|--------------------|--|---|

GO TO AS10 RULE

AS7. [J36] Child of: [CYAQRTH], [CYNAMF CYNAML], age: [AGEIWDATE]

Is [he / she] Spanish, Hispanic, or Latino? That is, Mexican, Mexican American, Chicano, Puerto Rican, Cuban, or other Spanish?

| | | | |
|-------------------------|------------|--|------------|
| 0. Not Spanish/Hispanic | 1. Mexican | 2. Mexican American | 3. Chicano |
| 4. Puerto Rican | 5. Cuban | 7. Other-specify (AS7SPEC. Specify (STRING 100)) | |

AS8. [J36] Child of: [CYAQRTH], [CYNAMF CYNAML], age: [AGEIWDATE]

What is [his / her] race? Is [he / she] white, black, American Indian, Alaska Native, Asian, Native Hawaiian, or Pacific Islander?

- ENTER all that apply
- PROBE: Any others?

| | | |
|--|--------------------------------------|---------------------|
| 1. White | 2. Black, African-American, or Negro | |
| 3. American Indian or Alaska Native | 5. Native Hawaiian | 6. Pacific Islander |
| 7. Other-specify (AS8SPEC. Specify (STRING 100)) | DK/RF | 4. Asian |

GO TO AS10 RULE

↓

AS8A. [J36] Child of: [CYAQRTH], [CYNAMF CYNAML], age: [AGEIWDTE]

Would that be Chinese, Filipino, Asian Indian, or what?

1. Chinese

2. Filipino

3. Asian Indian

4. Japanese

5. Korean

6. Vietnamese

7. Other Asian-specify (AS8ASPEC. Specify (STRING 100))

AS10 Rule: Whether More Children at J36

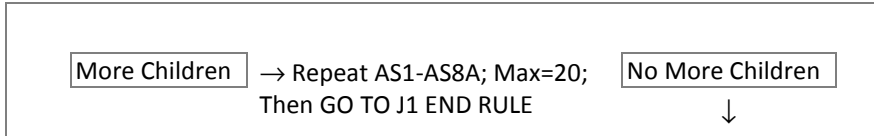

END AS1_AS9

J1 End Rule: Whether More Eligible FU Members

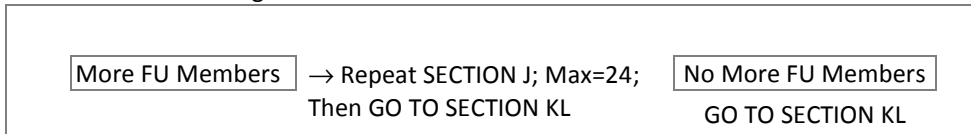

END SECTION_J

Section KL: New Head/SP Background; Returning Head/SP Education

[TOC](#)

SECTION_KL

KL1CKPT. CAI Checkpoint: Whether New or Returning Spouse/Partner or Head in FU

1. (REINT & ((CYFUHU=FU & CYAQRTH=201-222 & PYAQRTH<>101-222) OR (CYFUHU=FUMI & CYAQRTH=201-222))) **OR** (All Other IWTYPEs & CYFUHU=FU, FUMI & CYAQRTH=201-222)
2. (REINT & ((CYFUHU=FU & CYAQRTH=101-102 & PYAQRTH<>101-102, 201-222) OR (CYFUHU=FUMI & CYAQRTH=101-102))) **OR** (All Other IWTYPEs & CYFUHU=FU, FUMI & CYAQRTH=101-102)
3. REINT & (CYFUHU=FU & CYAQRTH=201-222 & PYAQRTH=101-102, 201-222)
4. REINT & (CYFUHU=FU & CYAQRTH=101, 102 & PYAQRTH=101-102, 201-222)

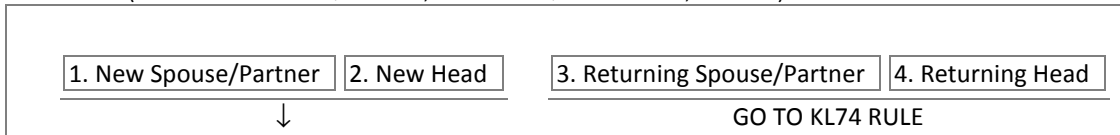

SECTION_KL.KL[1-2] [1]=Current Spouse/Partner, [2]=Current Head

LINENUM. AQSN of Current Spouse/Partner (Head)

KL2CITY. [\[CYAQRTH\]](#), [\[CYNAMF CYNAML\]](#)

Now I have some questions about [your / [SP / HEAD]'s] family and past experiences. Where was [your / her / his] father born?

- [ACCEPT Father substitute](#)
- [For Don't Know, ENTER \[Ctrl D\]](#)
- [For Refusal, ENTER \[Ctrl R\]](#)

String 25

KL2STATE. [\[CYAQRTH\]](#), [\[CYNAMF CYNAML\]](#)

(What State is that in?)

[KL2CITY]

- [Start typing the name of the State to bring up the look-up list](#)
- [IF foreign country, ENTER \[FOR\] to select "Foreign Country"](#)

String 30; U.S. State → GO TO KL3CITY Foreign Country DK/RF → GO KL3CITY

↓

KL2COUNTRY. [\[CYAQRTH\]](#), [\[CYNAMF CYNAML\]](#)

(What Country is that in?)

[KL2CITY], [KL2STATE]

- [Start typing the name of the Foreign Country to bring up the look-up list](#)

String 25; Country

KL3CITY. [\[CYAQRTH\]](#), [\[CYNAMF CYNAML\]](#)

Where did [your / her / his] father grow up?

- [Most of the years from ages 6 to 16](#)
- [For Don't Know, ENTER \[Ctrl D\]](#)
- [For Refusal, ENTER \[Ctrl R\]](#)

String 25

KL3STATE. [CYAQRTH], [CYNAMF CYNAML]

(What State is that in?)

[KL3CITY]

- Start typing the name of the State to bring up the look-up list
- IF foreign country, ENTER [FOR] to select "Foreign Country"

String 30; U.S. State → GO TO KL4 Foreign Country DK/RF → GO KL4



KL3COUNTRY. [CYAQRTH], [CYNAMF CYNAML]

(What Country is that in?)

[KL3CITY], [KL3STATE]

- Start typing the name of the Foreign Country to bring up the look-up list

String 25; Country

KL4. [CYAQRTH], [CYNAMF CYNAML]

Where did [your / her / his] father receive his education - in the United States, outside the United States, or both?

1. United States only 2. Outside U.S. only 3. Both in U.S. and outside DK 5. Had no education RF



GO TO KL7CKPT



GO TO KL10

KL5. [CYAQRTH], [CYNAMF CYNAML]

How much education did [your / her / his] father complete (in the United States)?

1. 0 – 5 grades 2. 6 – 8 grades; "Grade School" 9 – 11 grades; "Junior High"

GO TO KL6

4. 12 grades; "High School" 5. 12 grades plus non-academic training

6. 13 – 14 years; Some college; Associate's Degree

7. 15 – 16 years; College; Bachelor's Degree

8. 17 or more years; College; Graduate work; Ph.D, Professional degree

DK

RF

GO TO KL7CKPT



GO TO KL6

SIGNAL FOR KL5=DK:

What is your best estimate, would you say...

- READ code list below

0 - 5 grades, 6 - 8 grades, 9 - 11 grades, 12 grades, 5. 12 grades plus non-academic training,

6. 13 - 14 years or an Associate's Degree, 7. 15 - 16 years or a Bachelor's Degree, or

8. 17 or more years - a graduate degree, Ph.D, or professional degree?

KL6. [CYAQRTH], [CYNAMF CYNAML]

Could he read and write (in English)?

1. Yes 5. No

KL7CKPT. CAI Checkpoint: Whether Spouse/Partner's (Head's) Father Educated Outside U.S.

1. Outside U.S. (KL4=2, 3) 5. All Others (KL4=1, 5, DK/RF) → GO TO KL10



KL8. [CYAQRTH], [CYNAMF CYNAML]

How many years of school did he complete outside of the U.S.?

1 – 25

KL9. [CYAQRTH], [CYNAMF CYNAML]

What was the highest degree or certificate he earned outside the U.S.?

String 100

KL10. [CYAQRTH], [CYNAMF CYNAML]

What was [your / her / his] father's usual occupation when [you were / [she / he] was] growing up? What kind of work did he do? What were his most important activities or duties?

- DO NOT PROBE

String 500

KL11. [CYAQRTH], [CYNAMF CYNAML]

What kind of business or industry was that in?

- DO NOT PROBE

String 500

KL12CITY. [CYAQRTH], [CYNAMF CYNAML]

These next questions are about [your / [SP / HEAD]'s] mother. Where was [your / her / his] mother born?

- ACCEPT Mother substitute
- For Don't Know, ENTER [Ctrl D]
- For Refusal, ENTER [Ctrl R]

String 25

KL12STATE. [CYAQRTH], [CYNAMF CYNAML]

(What State is that in?)

[KL12CITY]

- Start typing the name of the State to bring up the look-up list
- IF foreign country, ENTER [FOR] to select "Foreign Country"

String 30; U.S. State → GO TO KL13CITY Foreign Country DK/RF → GO KL13CITY



KL12COUNTRY. [CYAQRTH], [CYNAMF CYNAML]

(What Country is that in?)

[KL12CITY, KL12STATE]

- Start typing the name of the Foreign Country to bring up the look-up list

String 25; Country

KL13CITY. [CYAQRTH], [CYNAMF CYNAML]

Where did [your / her / his] mother grow up?

- Most of the years from ages 6 to 16
- For Don't Know, ENTER [Ctrl D]
- For Refusal, ENTER [Ctrl R]

String 25

KL13STATE. [CYAQRTH], [CYNAMF CYNAML]

(What State is that in?)

[KL13CITY]

- Start typing the name of the State to bring up the look-up list
- IF foreign country, ENTER [FOR] to select "Foreign Country"

String 30; U.S. State → GO TO KL14 Foreign Country DK/RF → GO KL14



KL13COUNTRY. [CYAQRTH], [CYNAMF CYNAML]

(What Country is that in?)

[KL13CITY, KL13STATE]

- Start typing the name of the Foreign Country to bring up the look-up list

String 25; Country

KL14. [CYAQRTH], [CYNAMF CYNAML]

Where did [your / her / his] mother receive his education - in the United States, outside the United States, or both?

| | | | | | |
|-----------------------|----------------------|-----------------------------|----|---------------------|----|
| 1. United States only | 2. Outside U.S. only | 3. Both in U.S. and outside | DK | 5. Had no education | RF |
| ↓ | GO TO KL17CKPT | ↓ | | GO TO KL20 | |

KL15. [CYAQRTH], [CYNAMF CYNAML]

How much education did [your / her / his] mother complete (in the United States)?

| | | | |
|-----------------|--|---|------------|
| 1. 0 – 5 grades | 2. 6 – 8 grades; “Grade School” | 3. 9 – 11 grades; “Junior High” | |
| GO TO KL16 | 4. 12 grades; “High School” | 5. 12 grades plus non-academic training | |
| | 6. 13 – 14 years; Some college; Associate’s Degree | | |
| | 7. 15 – 16 years; College; Bachelor’s Degree | | |
| | 8. 17 or more years; College; Graduate work; Ph.D, Professional degree | DK | |
| | GO TO KL17CKPT | ↓ | GO TO KL16 |

SIGNAL FOR KL15=DK:

What is your best estimate, would you say...

- Read code list below

| | | | | |
|--|---|----------------|------------|--|
| 0 - 5 grades, | 6 - 8 grades, | 9 - 11 grades, | 12 grades, | 5. 12 grades plus non-academic training, |
| 6. 13 - 14 years or an Associate’s Degree, | 7. 15 - 16 years or a Bachelor’s Degree, or | | | |
| 8. 17 or more years - a graduate degree, Ph.D, or professional degree? | | | | |

KL16. [CYAQRTH], [CYNAMF CYNAML]

Could she read and write (in English)?

| | |
|--------|-------|
| 1. Yes | 5. No |
|--------|-------|

KL17CKPT. CAI Checkpoint: Whether Spouse/Partner’s (Head’s) Mother Educated Outside U.S.

| | | |
|-----------------------------|----------------------------------|--------------|
| 1. Outside U.S. (KL14=2, 3) | 5. All Others (KL14=1, 5, DK/RF) | → GO TO KL20 |
| ↓ | | |

KL18. [CYAQRTH], [CYNAMF CYNAML]

How many years of school did she complete outside of the U.S.?

| |
|--------|
| 1 – 25 |
|--------|

KL19. [CYAQRTH], [CYNAMF CYNAML]

What was the highest degree or certificate she earned outside the U.S.?

| |
|------------|
| String 100 |
|------------|

KL20. [CYAQRTH], [CYNAMF CYNAML]

What was [your / her / his] mother's usual occupation when [you were / [she / he] was] growing up? What kind of work did she do? What were her most important activities or duties?

- DO NOT PROBE

String 500

KL21. [CYAQRTH], [CYNAMF CYNAML]

What kind of business or industry was that in?

- DO NOT PROBE

String 500

KL22. [CYAQRTH], [CYNAMF CYNAML]

Now I have some questions about brothers and sisters. Did [you / [SP / HEAD]] have any brothers?

- INCLUDE natural siblings only

1. Yes 5. No → GO TO KL28

↓

KL23. [CYAQRTH], [CYNAMF CYNAML]

How many brothers was that?

1

↓

KL24. [CYAQRTH], [CYNAMF CYNAML]

Is [he / her / his] brother still living?

1. Yes 5. No

KL25. [CYAQRTH], [CYNAMF CYNAML]

[Is / Was] he older than [you / [SP / HEAD]]?

1. Yes 5. No

2 – 25

DK/RF

→ GO TO KL28

↓

KL26. [CYAQRTH], [CYNAMF CYNAML]

How many of them are still living?

0 – [[KL23] / 25]

KL27. [CYAQRTH], [CYNAMF CYNAML]

[Are / Were] any of [your / her / his] brothers older than [you are / [she / he] is]?

1. Yes 5. No

KL28. [CYAQRTH], [CYNAMF CYNAML]

Did [you / [SP / HEAD]] have any sisters?

- INCLUDE natural siblings only

1. Yes 5. No → GO TO KL33CITY

↓

KL29. [CYAQRTH], [CYNAMF CYNAML]

How many sisters was that?

1

↓

KL30. [CYAQRTH], [CYNAMF CYNAML]

Is [she / her / his] sister still living?

1. Yes 5. No

KL31. [CYAQRTH], [CYNAMF CYNAML]

[Is / Was] she older than [you / [SP / HEAD]]?

1. Yes 5. No

2 – 25

DK/RF

→ GO TO KL33CITY

↓

KL32. [CYAQRTH], [CYNAMF CYNAML]

How many of them are still living?

0 – [[KL28] / 25]

KL33. [CYAQRTH], [CYNAMF CYNAML]

[Are / Were] any of [your / her / his] sisters older than [you are [she / he] is]?

1. Yes 5. No

KL33CITY. [CYAQRTH], [CYNAMF CYNAML]

[RETURNING SP /HEAD: Now I have some questions about [your / [SP / HEAD]'s] family and past experiences.]
In what city and state [were you / was [SP / HEAD]] born?

- For Don't Know, ENTER [Ctrl D]
- For Refusal, ENTER [Ctrl R]

String 25

KL33STATE. [CYAQRTH], [CYNAMF CYNAML]

(What State is that in?)

[KL33CITY]

- Start typing the name of the State to bring up the look-up list
- IF foreign country, ENTER [FOR] to select "Foreign Country"

String 30; U.S. State → GO TO KL34 Foreign Country DK/RF



SIGNAL FOR IMM16IND=1-4 & KL33STATE=U.S. STATE (STATECODENUM=1-51):

IWER: You entered that this FU member was born in the United States, but she/he was screened during the 2016 New Immigrant Screener as an immigrant who was outside of the U.S. Please verify.

KL33COUNTRY. [CYAQRTH], [CYNAMF CYNAML]

(What Country is that?)

[KL33CITY, KL33STATE]

- Start typing the name of the Foreign Country to bring up the look-up list

String 25; U. S. → GO TO KL34 Foreign Country DK/RF



KL33YEAR. [CYAQRTH], [CYNAMF CYNAML]

In what year did [you / she / he] come to live in the United States?

[KL33CITY, KL33COUNTRY]

- ENTER Year
- ENTER [9997] if not living in the United States
- If needed, PROBE for the **most recent time** [SP /HEAD] came to live in the U.S.

1901 – [CYEAR] 9997. Not living in United States

SIGNAL FOR IMM16IND=1-4 & KL33YEAR<1998:

IWER: You entered that this FU member came to live in the United States before 1998, but she/he was screened during the 2016 New Immigrant Screener as an immigrant who was not in the U.S. in 1997. Please verify.

SIGNAL FOR IMM16IND=1-4 & KL33YEAR=9997:

IWER: You entered that this FU member is not living in the United States, but she/he was screened during the 2016 New Immigrant Screener as an immigrant who was currently living in the U.S. Please verify.

KL34. [CYAQRTH], [CYNAMF CYNAML]

Did [you / [SP / HEAD]] grow up on a farm, in a small town, in a large city, or what?

1. Farm; country 2. Small town; suburb 3. Large city 4. Other-specify (KL34SPEC. Specify (String 100))

KL35STATE. [CYAQRTH], [CYNAMF CYNAML]

In what State (of the U.S.) was that?

- Start typing the name of the State to bring up the look-up list
- IF foreign country, ENTER [FOR] to select "Foreign Country"

String 30; U.S. State



KL35COUNTY. [CYAQRTH], [CYNAMF CYNAML]

Can you tell me what County that was?

- For Don't Know, ENTER [Ctrl D]
- For Refusal, ENTER [Ctrl R]

String 25 GO TO KL36 DK/RF



KL35CITY. [CYAQRTH], [CYNAMF CYNAML]

What was the name of the nearest town or city?

- For Don't Know, ENTER [Ctrl D]
- For Refusal, ENTER [Ctrl R]

String 25

Foreign Country DK/RF



KL35COUNTRY. [CYAQRTH], [CYNAMF CYNAML]

In what Country was that?

- Start typing the name of the Foreign Country to bring up the look-up list

String 25; Country

KL36. [CYAQRTH], [CYNAMF CYNAML]

[Have you / Has [SP / HEAD]] lived in any other states or countries besides where [you are / [he / she] is] currently living and where [you / she / he] grew up, including time spent abroad while in the armed forces?

- "LIVED IN" means stayed at least 3 months

1. Yes 5. No

KL37. [CYAQRTH], [CYNAMF CYNAML]

Were [your / [SP / HEAD]'s] parents poor when [you were / [she / he] was] growing up, pretty well off, or what?

1. Poor 3. Average; it varied 5. Pretty well off

KL38. [CYAQRTH], [CYNAMF CYNAML]

[Were you / Was [she / he]] living with both [your / her / his] natural parents most of the time until [you were / [she / he] was] age 16?

1. Yes 5. No

KL39. [CYAQRTH], [CYNAMF CYNAML]

In order to get an idea of the different races and ethnic groups that participate in the study, I would like to ask you about [your / [SP / HEAD]'s] background. [Are you / Is [he / she]] Spanish, Hispanic, or Latino? That is, Mexican, Mexican American, Chicano, Puerto Rican, Cuban, or other Spanish?

0. Not Spanish/Hispanic 1. Mexican 2. Mexican American 3. Chicano
4. Puerto Rican 5. Cuban 7. Other-specify (KL39SPEC. Specify (STRING 100))

KL40. [CYAQRTH], [CYNAMF CYNAML]

What is [your / her / his] race? [Are you / Is [he / she]] white, black, American Indian, Alaska Native, Asian, Native Hawaiian, or Pacific Islander?

- ENTER all that apply
- PROBE: Any others?

| | | |
|---|--------------------------------------|---------------------|
| 1. White | 2. Black, African-American, or Negro | |
| 3. American Indian or Alaska Native | 5. Native Hawaiian | 6. Pacific Islander |
| 7. Other-specify (KL40SPEC. Specify (STRING 100)) | DK/RF | 4. Asian |

GO TO KL41 RULE ↓

KL40A. [CYAQRTH], [CYNAMF CYNAML]

Would that be Chinese, Filipino, Asian Indian, or what?

| | | | | | |
|--|-------------|-----------------|-------------|-----------|---------------|
| 1. Chinese | 2. Filipino | 3. Asian Indian | 4. Japanese | 5. Korean | 6. Vietnamese |
| 7. Other Asian-specify (KL40ASPEC. Specify (STRING 100)) | | | | | |

KL41. [CYAQRTH], [CYNAMF CYNAML]

What is [your / her / his] ancestry or ethnic origin? From what country or part of the world did [your / her / his] ancestors come from?

- PROBE: Is there a second? (What is it?)
- IF R reports a State in the U.S., ENTER [America]

String 200

KL42. [CYAQRTH], [CYNAMF CYNAML]

[Have you / Has [she / he]] ever been in the United States military service?

| | |
|--------|-------|
| 1. Yes | 5. No |
|--------|-------|

KL43. [CYAQRTH], [CYNAMF CYNAML]

Where did [you / [SP / HEAD]] receive [your / her / his] education — in the United States, outside the United States, or both?

| | | | | | |
|------------------|----------------------|-----------------------------|----|---------------------|----|
| 1. United States | 2. Outside U.S. only | 3. Both in U.S. and outside | DK | 5. Had no education | RF |
|------------------|----------------------|-----------------------------|----|---------------------|----|

↓ GO TO KL59CKPT ↓ GO TO KL59CKPT

KL44. [CYAQRTH], [CYNAMF CYNAML]

Now I would like to talk about the education [you have / [she / he] has] received. Did [you / she / he] graduate from high school, get a GED, or neither?

- ENTER [3] if R says still in school (attending grade 1-12) or working on a GED

| | | | |
|-------------------------------|--------------|------------|-------|
| 1. Graduated from high school | 2. Got a GED | 3. Neither | DK/RF |
|-------------------------------|--------------|------------|-------|

↓ GO TO KL46 GO TO KL49 GO TO KL51

KL45MO. [CYAQRTH], [CYNAMF CYNAML]

In what month and year did [you / she / he] graduate?

- SELECT Month and [Enter] to go to next screen for year
- IF NECESSARY: What would be your best estimate?

| | | | | | |
|------------|-------------|--------------|-------------|--------------|--------------|
| 1. January | 2. February | 3. March | 4. April | 5. May | 6. June |
| 7. July | 8. August | 9. September | 10. October | 11. November | 12. December |
| 21. Winter | 22. Spring | 23. Summer | 24. Fall | | |

KL45YR. [CYAQRTH], [CYNAMF CYNAML]

The month entered is: [KL45MO]

- ENTER the year below

1920 – [CYEAR]

GO TO KL51

KL46. [CYAQRTH], [CYNAMF CYNAML]

How many grades of regular school did [you / she / he] finish prior to getting [your / her / his] GED?

- Record last grade finished prior to receiving GED
- If needed: Regular school includes high school and schooling that leads to a college or professional school degree.

0. None → GO TO KL48MO

1. First grade 2. Second grade 3. Third grade 4. Fourth grade

5. Fifth grade 6. Sixth grade 7. Seventh grade 8. Eighth grade

9. Ninth grade 10. Tenth grade 11. Eleventh grade DK/RF → GO TO KL48MO



KL47MO. [CYAQRTH], [CYNAMF CYNAML]

In what month and year did [you / she / he] last attend [KL46]?

- SELECT Month and [Enter] to go to next screen for year
- IF NECESSARY: What would be your best estimate?

1. January 2. February 3. March 4. April 5. May 6. June

7. July 8. August 9. September 10. October 11. November 12. December

21. Winter 22. Spring 23. Summer 24. Fall

KL47YR. [CYAQRTH], [CYNAMF CYNAML]

The month entered is: [KL47MO]

- ENTER the year below

1920 – [CYEAR]

KL48MO. [CYAQRTH], [CYNAMF CYNAML]

In what month and year did [you / she / he] receive [your / her / his] GED?

- SELECT Month and [Enter] to go to next screen for year
- IF NECESSARY: What would be your best estimate?

1. January 2. February 3. March 4. April 5. May 6. June

7. July 8. August 9. September 10. October 11. November 12. December

21. Winter 22. Spring 23. Summer 24. Fall

KL48YR. [CYAQRTH], [CYNAMF CYNAML]

The month entered is: [KL48MO]

- ENTER the year below

1920 – [CYEAR]

GO TO KL51

KL49. [CYAQRTH], [CYNAMF CYNAML]

How many grades of regular school did [you / she / he] finish?

- Record last grade finished
- If needed: Regular school includes high school and schooling that leads to a college or professional school degree.

| | | | |
|----------------|-----------------|--------------------|--------------------|
| 0. None | → GO TO KL51 | | |
| 1. First grade | 2. Second grade | 3. Third grade | 4. Fourth grade |
| 5. Fifth grade | 6. Sixth grade | 7. Seventh grade | 8. Eighth grade |
| 9. Ninth grade | 10. Tenth grade | 11. Eleventh grade | DK/RF → GO TO KL51 |



KL50MO. [CYAQRTH], [CYNAMF CYNAML]

In month and what year did [you / she / he] last attend [KL49]?

- SELECT Month and [Enter] to go to next screen for year
- IF NECESSARY: What would be your best estimate?

| | | | | | |
|------------|-------------|--------------|-------------|--------------|--------------|
| 1. January | 2. February | 3. March | 4. April | 5. May | 6. June |
| 7. July | 8. August | 9. September | 10. October | 11. November | 12. December |
| 21. Winter | 22. Spring | 23. Summer | 24. Fall | | |

KL50YR. [CYAQRTH], [CYNAMF CYNAML]

The month entered is: [KL50MO]

- ENTER the year below

| |
|----------------|
| 1920 – [CYEAR] |
|----------------|

KL51. [CYAQRTH], [CYNAMF CYNAML]

Did [you / she / he] attend college?

| | | |
|--------|-------|------------------|
| 1. Yes | 5. No | → GO TO KL59CKPT |
|--------|-------|------------------|



KL52MO. [CYAQRTH], [CYNAMF CYNAML]

In what month and year did [you / she / he] last attend college?

- If still in school, ENTER [96] for month
- SELECT Month and [Enter] to go to next screen for year
- IF NECESSARY: What would be your best estimate?

| | | | | | | |
|------------|-------------|--------------|-------------|--------------|--------------|---------------------|
| 1. January | 2. February | 3. March | 4. April | 5. May | 6. June | |
| 7. July | 8. August | 9. September | 10. October | 11. November | 12. December | 96. Still in school |
| 21. Winter | 22. Spring | 23. Summer | 24. Fall | DK/RF | | |



GO TO KL53

KL52YR. [CYAQRTH], [CYNAMF CYNAML]

The month entered is: [KL52MO]

- ENTER the year below

9996 If still in school

| | |
|----------------|-----------------------|
| 1920 – [CYEAR] | 9996. Still in school |
|----------------|-----------------------|

KL53. [CYAQRTH], [CYNAMF CYNAML]

What is the highest year of college [you have / [he / she] has] completed?

- **IF R gives a degree:** How many years of college [have you / has [she / he]] completed? We'll talk about any college degrees [you have / [he / she] has] earned next.

| | | | |
|-----------------------|---------------|-----------------------|----------------|
| 0. Less than one year | 1. One year | 2. Two years | 3. Three years |
| GO TO KL59CKPT | 4. Four years | 5. Five years or more | DK/RF |



KL54. [CYAQRTH], [CYNAMF CYNAML]

Did [you / she / he] receive a college degree?

| | | |
|--------|-------|------------------|
| 1. Yes | 5. No | → GO TO KL59CKPT |
|--------|-------|------------------|



KL55. [CYAQRTH], [CYNAMF CYNAML]

What is the highest college degree [you have / [he / she] has] received?

- **PROBE for the highest degree received**

| | |
|----------------------------|--|
| 1. Associate's degree/AA | 3. Master's degree/MA/MS/MBA |
| 2. Bachelor's degree/BA/BS | 4. Doctorate/PhD |
| | 5. LLB, JD (Law degrees) |
| | 6. MD, DDS, DVM, DO (Medical degrees) |
| | 8. Honorary degree |
| DK/RF | 97. Other-specify (KL55SPEC. Specify (String 100)) |

GO TO KL55E



KL55A. [CYAQRTH], [CYNAMF CYNAML]

What was [your / her / his] major at the college or university from which [you / he / she] received [your / his / her] bachelor's degree?

- **Probe for details and dual majors**

| |
|------------|
| String 100 |
|------------|

KL55B. [CYAQRTH], [CYNAMF CYNAML]

What was the name of the college or university (from which [you / he / she] received [your / his / her] bachelor's degree)?

| |
|------------|
| String 100 |
|------------|

KL55CCITY. [CYAQRTH], [CYNAMF CYNAML]

Where was it located?

- **If needed:** In what city and state was the college or university from which [you / she / he] received [your / her / his] bachelor's degree?

| |
|------------|
| String 100 |
|------------|

KL55CSTATE. [CYAQRTH], [CYNAMF CYNAML]

(Where was it located?)

- **If needed:** In what state was the college or university from which [you / she / he] received [your / her / his] bachelor's degree?
- **Start typing the name of the State to bring up the look-up list**
- **IF foreign country, ENTER [FOR] to select "Foreign Country"**

| | | | | |
|-----------------------|---------|-----------------|-------|---------|
| String 30; U.S. State | → GO TO | Foreign Country | DK/RF | → GO TO |
| | KL55DMO | | | KL55DMO |



KL55CCOUNTRY. [CYAQRTH], [CYNAMF CYNAML]

(Where was it located?)

- **If needed:** In what country was the college or university from which [you / she / he] received [your / her / his] bachelor's degree?
- **Start typing the name of the Foreign Country to bring up the look-up list**

String 30; Country

KL55DMO. [CYAQRTH], [CYNAMF CYNAML]

In what month and year did [you / he / she] receive [your / his / her] bachelor's degree?

- **SELECT Month and [Enter] to go to next screen for year**
- **IF NECESSARY:** What would be your best estimate?

| | | | |
|--------------|-------------|--------------|--------------|
| 1. January | 2. February | 3. March | 4. April |
| 5. May | 6. June | 7. July | 8. August |
| 9. September | 10. October | 11. November | 12. December |
| 21. Winter | 22. Spring | 23. Summer | 24. Fall |

KL55DYR. [CYAQRTH], [CYNAMF CYNAML]

(In what month and year did [you / he / she] receive [your / his / her] bachelor's degree?

The month entered is: [KL55DMO]

- **ENTER the year below**

1920 – [CYEAR]

KL55E. [CYAQRTH], [CYNAMF CYNAML] [KL55]

(And) What was [your / her / his] [KL55=BACHELORS: major / ALL OTHERS: area of study] at the college or university from which [you / he / she] received [your / his / her] highest degree?

- **Probe for details and dual majors**

String 100

KL56. [CYAQRTH], [CYNAMF CYNAML] [KL55]

What was the name of the college or university?

- **If needed:** What was the name of the college or university from which [you / she / he] received [your / her / his] highest degree?

String 100

KL57CITY. [CYAQRTH], [CYNAMF CYNAML] [KL55]

Where was it located?

- **If needed:** In what city and state was the college or university from which [you / she / he] received [your / her / his] highest degree?

String 100

KL57STATE. [CYAQRTH], [CYNAMF CYNAML] [KL55]

(Where was it located?)

- **If needed:** In what state was the college or university from which [you / she / he] received [your / her / his] highest degree?
- Start typing the name of the State to bring up the look-up list
- IF foreign country, ENTER [FOR] to select "Foreign Country"

String 30; U.S. State → GO TO KL58MO Foreign Country DK/RF → GO TO KL58MO



KL57COUNTRY. [CYAQRTH], [CYNAMF CYNAML] [KL55]

(Where was it located?)

- **If needed:** In what country was the college or university from which [you / she / he] received [your / her / his] highest degree?
- Start typing the name of the Foreign Country to bring up the look-up list

String 30: Country

KL58MO. [CYAQRTH, CYNAMF CYNAML] [KL55]

In what month and year did [you / he / she] receive [your / his / her] highest degree?

- **SELECT Month and [Enter] to go to next screen for year**
- **IF NECESSARY:** What would be your best estimate?

| | | | | | |
|------------|-------------|--------------|-------------|--------------|--------------|
| 1. January | 2. February | 3. March | 4. April | 5. May | 6. June |
| 7. July | 8. August | 9. September | 10. October | 11. November | 12. December |
| 21. Winter | 22. Spring | 23. Summer | 24. Fall | | |

KL58YR. [CYAQRTH, CYNAMF CYNAML] [KL55]

The month entered is: [KL58MO]

- **ENTER the year below**

1920 – [CYEAR]

KL59CKPT. CAI Checkpoint: Where Spouse/Partner (Head) Educated

1. Outside U.S. (KL43=2, 3) 3. U.S. Only (KL43=1, DK) 5. All Others (KL43=5, RF) → GO TO KL62



GO TO KL61ACKPT

KL60. [CYAQRTH], [CYNAMF CYNAML]

How many years of school did [you / she / he] complete outside of the U.S.?

1 – 25

KL61. [CYAQRTH], [CYNAMF CYNAML]

What was the highest degree or certificate [you / she / he] earned outside the U.S.?

String 100

KL61ACKPT. CAI Checkpoint: Whether Spouse/Partner (Head) Still In School

1. Still In School (KL52MO=96 or KL52YR=9996) → GO TO KL61B 5. All Others



KL61A. [CYAQRTH], [CYNAMF CYNAML]

[Are you / Is [she / he]] attending or enrolled in regular school? Regular school includes high school and schooling that leads to a college or professional school degree.

1. Yes 5. No → GO TO KL62



KL61B. [CYAQRTH], [CYNAMF CYNAML]

[KL61ACKPT=STILL IN SCHOOL: Earlier you said [you are / [SP / HEAD] is] still in school.]

What grade or year [are you / is [she / he]] attending?

| | | | | |
|-----------------------------------|---------------------------------------|-----------------|-----------------|-----------------|
| 1. First grade | 2. Second grade | 3. Third grade | 4. Fourth grade | 5. Fifth grade |
| 6. Sixth grade | 7. Seventh grade | 8. Eighth grade | 9. Ninth grade | 10. Tenth grade |
| 11. Eleventh grade | 12. Twelfth grade, "High School", GED | | | |
| 13. 1st year college (freshman) | 14. 2nd year college (sophomore) | | | |
| 15. 3rd year college (junior) | 16. 4th year college (senior) | | | |
| 17. 5th year or higher of college | 18. Post-graduate work | | | |

KL62. [CYAQRTH], [CYNAMF CYNAML]

Did [you / she / he] receive any other degree or a certificate through a vocational school, a training school, or an apprenticeship program?

- IWER: This includes vocational training received in the military and military occupational specialties (MOS)

1. Yes 5. No → GO TO KL68



SECTION_KL.KL[1-2].KL63_KL67[1-5] [1]=Current Spouse/Partner, [2]=Current Head; [1-5]=Which degree/certificate

KL63. [CYAQRTH], [CYNAMF CYNAML]

What type of degree or certificate was that?

| | | | |
|---|----------------|------------|------------------------------|
| 1. Degree | 2. Certificate | 3. License | 4. Diploma (not High School) |
| 7. Other-specify (KL63SPEC. Specify (String 100)) | | | |

KL64. [CYAQRTH], [CYNAMF CYNAML]

In what field was that?

String 100

KL65. [CYAQRTH], [CYNAMF CYNAML]

From what type of institution or organization was that?

| | |
|---|--|
| 1. Vocational/Trade school | 2. Community/Junior college |
| 3. Business/Secretarial school | 4. Armed Forces |
| 5. High school | 6. Hospital/Health Care facility or school |
| 7. Cosmetology/Beauty/Barber school | 8. Police/Firefighter training program |
| 9. Job training through government; except code 8 | 10. Training by private employer |
| 11. Religious Institution or Bible College/School | 97. Other-specify (KL65SPEC. Specify (String 100)) |

KL66MO. [CYAQRTH], [CYNAMF CYNAML]

In what month and year did [you / she / he] receive that degree or certificate?

- SELECT Month and [Enter] to go to next screen for year
- IF NECESSARY: What would be your best estimate?

| | | | | | |
|------------|-------------|--------------|-------------|--------------|--------------|
| 1. January | 2. February | 3. March | 4. April | 5. May | 6. June |
| 7. July | 8. August | 9. September | 10. October | 11. November | 12. December |
| 21. Winter | 22. Spring | 23. Summer | 24. Fall | | |

KL66YR. [CYAQRTH], [CYNAMF CYNAML]

The month entered is: [KL66MO]

- ENTER the year below

| |
|----------------|
| 1920 – [CYEAR] |
|----------------|

KL67. [CYAQRTH], [CYNAMF CYNAML]

Did [you / she / he] receive any other training degree or certificate?

- This includes vocational training received in the military and military occupational specialties (MOS)

| | | |
|--------|----------------------------|-------|
| 1. Yes | → Repeat KL63–KL67; MAX=5; | 5. No |
|--------|----------------------------|-------|

Then GO TO KL68



END KL63_KL67

KL68. [CYAQRTH], [CYNAMF CYNAML]

What is [your / [SP / HEAD]'s] religious preference?

- IF answer is generic, such as “Christian” or “Protestant”, PROBE: What denomination is that?

| | | | | |
|-----------------|-------------|-----------|---------------|--|
| 0. None | 1. Catholic | 2. Jewish | 8. Protestant | 10. Non-Christian/Muslim/Buddhist |
| GO TO KL70 RULE | | | | ↓ |
| | | | | 13. Greek/Russian/Eastern Orthodox |
| | | | | 97. Other-Specify (KL68SPEC. Specify (String 100)) |
| | | | | DK/RF |

GO TO KL70 RULE

KL69. [CYAQRTH], [CYNAMF CYNAML]

What denomination is that?

| | | |
|--|------------------|----------------------------------|
| 03. Baptist | 04. Lutheran | 05. Methodist/ African Methodist |
| 06. Presbyterian | 07. Episcopalian | 08. Protestant, Unspecified |
| 12. Jehovah's Witness | 14. "Christian" | 18. Pentecostal/ Assembly of God |
| 97. Other-Specify (KL69SPEC. Specify (String 100)) | | |

KL70 Rule: Whether Spouse/Partner (Head) is 18 Years Old or Older

| | | |
|------------------------------|------------|-------------------|
| 18+ Years Old (AGEIWDATE>17) | All Others | → GO TO KL74 RULE |
| ↓ | | |

KL70. [CYAQRTH], [CYNAMF CYNAML]

How many years altogether [have you / has [she / he]] worked for money since [you were / [she / he] was] 18?

- FOR none, ENTER [0]
- [AGE 19 OR OLDER: FOR 1 year or less, ENTER [1]]
- [AGE 18: For less than 1 year, ENTER [95]]
- FOR all years since 18, ENTER [96]

| | | |
|---|-------------------|---|
| 0 | → GO TO KL74 RULE | [AGE 19 OR OLDER: 1 – [AGEIWDATE minus 18]] |
| | | [AGE 18: 95. Less than one year] 96. All years since 18 DK/RF |



KL71. [CYAQRTH], [CYNAMF CYNAML]

How many of these years did [you / she / he] work full-time for most or all of the year?

- FOR none, ENTER [0]
- [AGE 19 OR OLDER: FOR 1 year or less, ENTER [1]]
- [AGE 18: For less than 1 year, ENTER [95]]
- [KL70=96: FOR all years since 18, ENTER [96]]

| | | |
|---|-------------------|--|
| 0 | → GO TO KL74 RULE | [AGE 19 OR OLDER: 1 – [AGEIWDATE minus 18]] |
| | | [AGE 18: 95. Less than one year] [KL70=96: 96. All years since 18] DK/RF |



KL72. [CYAQRTH], [CYNAMF CYNAML]

Thinking of [your / her / his] first full-time regular job, what kind of work did [you / she / he] do?
What were [your / her / his] most important activities or duties?

- DO NOT PROBE

Open End

KL73. [CYAQRTH], [CYNAMF CYNAML]

What kind of business or industry was that in?

- DO NOT PROBE

Open End

KL74 Rule: Type of Spouse/Partner (Head)

| | | |
|----------------------------|-------------------------|-------------------------------|
| KL1CKPT=New Spouse/Partner | KL1CKPT=New Head | Returning Spouse/Partner/Head |
| Repeat SECTION KL For Head | GO TO IMMIGRANT SECTION | ↓ |

KL74. [CYAQRTH], [CYNAMF CYNAML]

Now I would like to talk about the education [you have / [SP / HEAD] has] received.

[Have you / Has [SP / HEAD]] attended regular school since our last interview on [PYIWDATE]? Regular school includes high school and schooling that leads to a college or professional school degree.

- ENTER [2] for "still in school"

| | | | |
|-------------|-----------------------------|----------------|-------|
| 1. Yes | 2. Still in school (IF VOL) | 5. No | DK/RF |
| GO TO KL74C | | GO TO KL84CKPT | |

KL74C. [CYAQRTH], [CYNAMF CYNAML]

Since our last interview on [PYIWDATE], where did [you / [SP / HEAD]] receive [your / her / his] education — in the United States, outside the United States, or both?

| | | | | | |
|-----------------------|----------------------|-----------------------------|----|----|-------------------|
| 1. United States only | 2. Outside U.S. only | 3. Both in U.S. and outside | DK | RF | → GO TO KL83ACKPT |
| ↓ | GO TO KL83ACKPT | | ↓ | | |

SECTION_KL.KL[1-2].KL76_KL83 [1]=Current Spouse/Partner, [2]=Current Head

KL76CKPT. CAI Checkpoint: Whether Preloaded Education Level is Less Than HS Grad/GED or Non-Response

| | | |
|--|---------------|---------------|
| 1. <HS Grad/GED (PYPERSINFO.COMPEDUC=0-11, NA) | 5. All Others | → GO TO KL78B |
|--|---------------|---------------|



KL76. [CYAQRTH], [CYNAMF CYNAML]

[COMPEDUC=0-11: (Since our last interview on [PYIWDATE],) did / COMPEDUC=NA: Did] [you / she / he] graduate from high school, get a GED, or neither?

- ENTER [3] if R says still in school (attending grade 1-12) or working on a GED

| | | | | |
|-------------------------------|--------------|------------|-------|---------------|
| 1. Graduated from high school | 2. Got a GED | 3. Neither | DK/RF | → GO TO KL78B |
|-------------------------------|--------------|------------|-------|---------------|



GO TO KL77A GO TO KL78A

KL77MO. [CYAQRTH], [CYNAMF CYNAML]

In what month and year did [you / he / she] graduate?

- [COMPEDUC=0-11: If needed: Between our last interview on [PYIWDATE] and now]
- SELECT Month and [Enter] to go to next screen for year
- If necessary: What would be your best estimate?

| | | | | | |
|------------|-------------|--------------|-------------|--------------|--------------|
| 1. January | 2. February | 3. March | 4. April | 5. May | 6. June |
| 7. July | 8. August | 9. September | 10. October | 11. November | 12. December |
| 21. Winter | 22. Spring | 23. Summer | 24. Fall | | |

KL77YR. [CYAQRTH], [CYNAMF CYNAML]

(In what month and year did [you / she / he] graduate?)

- [COMPEDUC=0-11: If needed: Between our last interview on [PYIWDATE] and now]
- The month entered is: [KL77MO]
- ENTER the year below

| |
|----------------|
| 1920 – [CYEAR] |
|----------------|

GO TO KL78B

CHECK: FOR KL77YR<P2YEAR & COMPEDUC=0-11

IWER: All years prior to [P2YEAR] are not allowed since we are asking about education since [PYIWDATE]. Please VERIFY Year graduated High School since [PYIWDATE]:

- If R confirms the year is before [P2YEAR], then select GOTO and ENTER [5] at KL74
- If R gives a year from [P2YEAR] to [CYEAR], then CLOSE and ENTER [Year] at this question

KL77A. [CYAQRTH], [CYNAMF CYNAML]

How many grades of regular school did [you / he / she] finish prior to getting [your / her / his] GED?

- Record last grade finished prior to receiving GED
- If needed: Regular school includes high school and schooling that leads to a college or professional school degree.

| | | | | | |
|----------------|-----------------|--------------------|-----------------|--|--|
| 0. None | → GO TO KL78MO | | | | |
| 1. First grade | 2. Second grade | 3. Third grade | 4. Fourth grade | | |
| 5. Fifth grade | 6. Sixth grade | 7. Seventh grade | 8. Eighth grade | | |
| 9. Ninth grade | 10. Tenth grade | 11. Eleventh grade | DK/RF | | |



GO TO KL78MO

KL77AMO. [CYAQRTH], [CYNAMF CYNAML]

In what month and year did [you / she / he] last attend [KL77A]?

- SELECT Month and [Enter] to go to next screen for year
- IF NECESSARY: What would be your best estimate?

| | | | | | |
|------------|-------------|--------------|-------------|--------------|--------------|
| 1. January | 2. February | 3. March | 4. April | 5. May | 6. June |
| 7. July | 8. August | 9. September | 10. October | 11. November | 12. December |
| 21. Winter | 22. Spring | 23. Summer | 24. Fall | | |

KL77AYR. [CYAQRTH], [CYNAMF CYNAML]

(In what month and year did [you / she / he] last attend [KL77A]?)

The month entered is: [KL77AMO]

- ENTER the year below

| |
|----------------|
| 1920 – [CYEAR] |
|----------------|

KL78MO. [CYAQRTH], [CYNAMF CYNAML]

In what month and year did [you / she / he] receive [your / her / his] GED?

- [COMPEDUC=0-11: If needed: Between our last interview on [PYIWDATE] and now]
- SELECT Month and [Enter] to go to next screen for year
- If necessary: What would be your best estimate?

| | | | | | |
|------------|-------------|--------------|-------------|--------------|--------------|
| 1. January | 2. February | 3. March | 4. April | 5. May | 6. June |
| 7. July | 8. August | 9. September | 10. October | 11. November | 12. December |
| 21. Winter | 22. Spring | 23. Summer | 24. Fall | | |

KL78YR. [CYAQRTH], [CYNAMF CYNAML]

(In what month and year did [you / she / he] receive [your / her / his] GED?)

- [COMPEDUC=0-11: If needed: Between our last interview on [PYIWDATE] and now]
- The month entered is: [KL78MO]
- ENTER the year below

| |
|----------------|
| 1920 – [CYEAR] |
|----------------|

GO TO KL78B

CHECK: FOR KL78YR<P2YEAR & COMPEDUC=0-11

IWER: All years prior to [P2YEAR] are not allowed since we are asking about education since [PYIWDATE]. Please VERIFY Year received GED since [PYIWDATE]:

- If R confirms the year is before [P2YEAR], then select GOTO and ENTER [5] at KL74
- If R gives a year from [P2YEAR] to [CYEAR], then CLOSE and ENTER [Year] at this question

KL78A. [CYAQRTH], [CYNAMF CYNAML]

How many grades of regular school did [you / she / he] finish?

- Record last grade finished
- If needed: Regular school includes high school and schooling that leads to a college or professional school degree.

| | | | | | |
|----------------|-----------------|--------------------|-----------------|--|-------------|
| 0. None | → GO TO KL78B | | | | |
| 1. First grade | 2. Second grade | 3. Third grade | 4. Fourth grade | | |
| 5. Fifth grade | 6. Sixth grade | 7. Seventh grade | 8. Eighth grade | | |
| 9. Ninth grade | 10. Tenth grade | 11. Eleventh grade | | | DK/RF |
| ↓ | | | | | GO TO KL78B |

KL78AMO. [CYAQRTH], [CYNAMF CYNAML]

In what month and what year did [you / she / he] last attend [KL78A]?

- SELECT Month and [Enter] to go to next screen for year
- IF NECESSARY: What would be your best estimate?

| | | | | | |
|------------|-------------|--------------|-------------|--------------|--------------|
| 1. January | 2. February | 3. March | 4. April | 5. May | 6. June |
| 7. July | 8. August | 9. September | 10. October | 11. November | 12. December |
| 21. Winter | 22. Spring | 23. Summer | 24. Fall | | |

KL78AYR. [CYAQRTH], [CYNAMF CYNAML]

(In what month and what year did [you / she / he] last attend [KL78A]?)

The month entered is: [KL78AMO]

- ENTER the year below

| |
|----------------|
| 1920 – [CYEAR] |
|----------------|

KL78B. [CYAQRTH], [CYNAMF CYNAML]

Did [you / she / he] attend college between [PYIWDATE] and now?

| | | |
|--------|-------|-------------------|
| 1. Yes | 5. No | → GO TO KL78DCKPT |
|--------|-------|-------------------|

↓

CHECK: FOR KL78B=NO, DK/RF & COMPEDUC=12-17

IWER: R reported that [SPOUSE/PARTNER / HEAD] attended school since [PYIWDATE], but we know (he / she) already graduated high school or received a GED BEFORE [P2YEAR]. Please VERIFY with R whether [this person attended college since \[PYIWDATE\] or is currently attending college:](#)

- If R says NO or DK/RF, then select GOTO and ENTER [5] or [DK, RF] at KL74
- If R says YES, then CLOSE here and ENTER [1] at this question

KL78BMO. [CYAQRTH], [CYNAMF CYNAML]

In what month and year did [you / she / he] last attend college?

- If needed: Between our last interview on [PYIWDATE] and now
- If still in school, ENTER [96] for month
- SELECT Month and [Enter] to go to next screen for year
- NECESSARY: What would be your best estimate?

| | | | | | |
|--------------|-------------|--------------|--------------|-------|---------------------|
| 1. January | 2. February | 3. March | 4. April | | |
| 5. May | 6. June | 7. July | 8. August | | |
| 9. September | 10. October | 11. November | 12. December | | |
| 21. Winter | 22. Spring | 23. Summer | 24. Fall | DK/RF | 96. Still in school |

↓

GO TO L78DCKPT

KL78BYR. [CYAQRTH], [CYNAMF CYNAML]

(In what month and year did [you / she / he] last attend college?)

- If needed: Between our last interview on [PYIWDATE] and now

The month entered is: [KL78BMO]

- ENTER the year below

9996 If still in school

| | |
|----------------|-----------------------|
| 1920 – [CYEAR] | 9996. Still in school |
|----------------|-----------------------|

CHECK: FOR KL78BYR<P2YEAR

IWER: All years prior to [P2YEAR] are not allowed since we are asking about education since [PYIWDATE]. Please VERIFY Year last attended college since [PYIWDATE]:

- If R confirms the year is before [P2YEAR], then select GOTO and ENTER [5] at KL78B
- If R gives a year from [P2YEAR] to [CYEAR], then CLOSE and ENTER [Year] at this question

KL78DCKPT. CAI Checkpoint: Whether Spouse/Partner (Head) Attended College since Last Wave

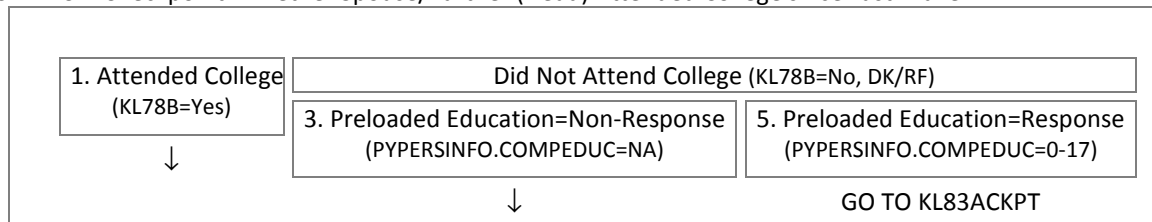

KL78D. [CYAQRTH], [CYNAMF CYNAML]

Altogether, what is the highest year of college [you have / [he / she] has] completed?

- IF R gives a degree: How many years of college [have you / has [she / he]] completed altogether? We'll talk about any college degrees [you have / [he / she] has] earned next.
- [KL78DCKPT=3: ENTER [0] if R says None or Never attended college]

| | | | |
|-----------------------|---------------|-----------------------|----------------|
| 0. Less than one year | 1. One year | 2. Two years | 3. Three years |
| GO TO KL83ACKPT | 4. Four years | 5. Five years or more | DK/RF |



KL78ECKPT. CAI Checkpoint: Whether Spouse/Partner (Head) Attended College since Last Wave

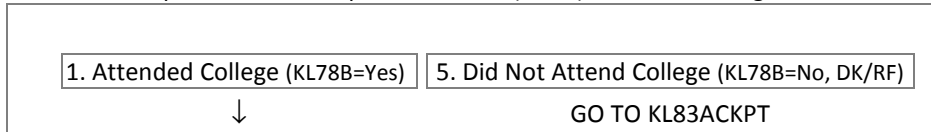

KL78E. [CYAQRTH], [CYNAMF CYNAML]

Did [you / she / he] receive a college degree between [PYIWDATE] and now?

| | | |
|--------|-------|-------------------|
| 1. Yes | 5. No | → GO TO KL83ACKPT |
|--------|-------|-------------------|



KL78F1. [CYAQRTH], [CYNAMF CYNAML]

(Since our last interview on [PYIWDATE],) what college degree did [you / [he / she]] receive?

- If more than one degree, PROBE for the **highest** degree received since [PYIWDATE]

| | | |
|----------------------------|---------------------------------------|---|
| 1. Associate's degree/AA | 3. Master's degree/MA/MS/MBA | |
| 2. Bachelor's degree/BA/BS | 4. Doctorate/PhD | 5. LLB, JD (Law degrees) |
| | 6. MD, DDS, DVM, DO (Medical degrees) | |
| | 8. Honorary degree | 97. Other-specify (KL78F1PEC. Specify (String 100)) |
| DK/RF | | |

GO TO KL78G



KL78F2. [CYAQRTH], [CYNAMF CYNAML]

What was [your / her / his] major at the college or university from which [you / he / she] received [your / his / her] bachelor's degree?

- Probe for details and dual majors

| |
|------------|
| String 100 |
|------------|

KL78F3. [CYAQRTH], [CYNAMF CYNAML]

What was the name of the college or university?

- **If needed:** What was the name of the college or university from which [you / she / he] received [your / her / his] bachelor's degree?

String 100

KL78F4CITY. [CYAQRTH], [CYNAMF CYNAML]

Where was it located?

- **If needed:** In what city and state was the college or university from which [you / she / he] received [your / her / his] bachelor's degree?

String 100

KL78F4STATE. [CYAQRTH], [CYNAMF CYNAML]

(Where was it located?)

- **If needed:** In what state was the college or university from which [you / she / he] received [your / her / his] bachelor's degree?
- **Start typing the name of the State to bring up the look-up list**
- **IF foreign country, ENTER [FOR] to select "Foreign Country"**

String 30: U.S. State → GO TO Foreign Country DK/RF → GO TO
 KL78F5MO ↓ KL78F5MO

KL78F4COUNTRY. [CYAQRTH], [CYNAMF CYNAML]

(Where was it located?)

- **If needed:** In what country was the college or university from which [you / he / she] received [your / his / her] bachelor's degree?
- **Start typing the name of the Foreign Country to bring up the look-up list**

String 30; Country

KL78F5MO. [CYAQRTH], [CYNAMF CYNAML]

In what month and year did [you / she / he] receive [your / his / her] bachelor's degree?

- **SELECT Month and [Enter] to go to next screen for year**
- **IF NECESSARY:** What would be your best estimate?

| | | | |
|--------------|-------------|--------------|--------------|
| 1. January | 2. February | 3. March | 4. April |
| 5. May | 6. June | 7. July | 8. August |
| 9. September | 10. October | 11. November | 12. December |
| 21. Winter | 22. Spring | 23. Summer | 24. Fall |

KL78F5YR. [CYAQRTH], [CYNAMF CYNAML]

(In what month and year did [you / she / he] receive [your / his / her] bachelor's degree)?

The month entered is: [KL78F5MO]

- **ENTER the year below**

1920 – [CYEAR]

KL78G. [CYAQRTH], [CYNAMF CYNAML] [KL78F1]

(And) What was [your / her / his] [KL78F1=BACHELORS: major / ALL OTHERS: area of study] at the college or university from which [you / he / she] received [your / his / her] highest degree since our last interview on [PYIWDATE]?

- Probe for details and dual majors

String 100

KL81. [CYAQRTH], [CYNAMF CYNAML] [KL78F1]

What was the name of the college or university?

- If needed: What was the name of the college or university from which [you / she / he] received [your / her / his] highest degree (since our last interview on [PYIWDATE])?

String 100

KL82CITY. [CYAQRTH], [CYNAMF CYNAML] [KL78F1]

Where was it located?

- If needed: In what city and state was the college or university from which [you / she / he] received [your / her / his] highest degree (since our last interview on [PYIWDATE])?

String 25

KL82STATE. [CYAQRTH], [CYNAMF CYNAML] [KL78F1]

(Where was it located?)

- If needed: In what state was the college or university from which [you / she / he] received [your / her / his] highest degree (since our last interview on [PYIWDATE])?
- Start typing the name of the State to bring up the look-up list
- If foreign country, ENTER [FOR] to select "Foreign Country"

String 30; U.S. State → GO TO KL83MO Foreign Country DK/RF → GO TO KL83MO



KL82COUNTRY. [CYAQRTH], [CYNAMF CYNAML] [KL78F1]

(Where was it located?)

- If needed: (In what country was the college or university from which [you / she / he] received [your / her / his] highest degree (since our last interview on [PYIWDATE])?)
- Start typing the name of the Foreign Country to bring up the look-up list

String 25; Country

KL83MO. [CYAQRTH], [CYNAMF CYNAML] [KL78F1]

In what month and year did [you / she / he] receive [your / her / his] highest degree?

- If needed: Between our last interview on [PYIWDATE] and now
- SELECT Month and [Enter] to go to next screen for year
- If necessary: What would be your best estimate?

| | | | | | |
|------------|-------------|--------------|-------------|--------------|--------------|
| 1. January | 2. February | 3. March | 4. April | 5. May | 6. June |
| 7. July | 8. August | 9. September | 10. October | 11. November | 12. December |
| 21. Winter | 22. Spring | 23. Summer | 24. Fall | | |

KL83YR. [CYAQRTH], [CYNAMF CYNAML] [KL78F1]

(In what month and year did [you / she / he] receive [your / her / his] highest degree?)

- If needed: Between our last interview on [PYIWDATE] and now
- The month entered is: [KL83MO]
- ENTER the year below

1920 – [YEAR]

CHECK: FOR KL83YR<P2YEAR

IWER: All years prior to [P2YEAR] are not allowed since we are asking about education since [PYIWDATE]. Please VERIFY Year received highest degree since [PYIWDATE]:

- If R confirms the year is before [P2YEAR], then select GOTO and ENTER [5] at KL78E
- If R gives a year from [P2YEAR] to [CYEAR], then CLOSE and ENTER [Year] at this question

END KL76_KL83

KL83ACKPT. CAI Checkpoint: Where Spouse/Partner (Head) Educated

| | | | |
|-------------------------------|-----------------------------|--------------------------|-----------------------|
| 1. Outside U.S. (KL74C =2, 3) | 3. U.S. Only (KL74C =1, DK) | 5. All Others (KL74C=RF) | → GO TO KL84 END RULE |
| ↓ | GO TO KL84CKPT | | |

KL83A. [CYAQRTH], [CYNAMF CYNAML]

Between [PYIWDATE] and now, how many years of school did [you / she / he] complete outside of the U.S.?

1 – 25

CHECK FOR KL83A=4-25

Number of years should be 1 to 3

KL83B. [CYAQRTH], [CYNAMF CYNAML]

(Between [PYIWDATE] and now,) what was the highest degree or certificate [you / she / he] earned outside the U.S.?

String 100

KL84CKPT. CAI Checkpoint: Whether Spouse/Partner (Head) Still In School

| | | |
|---|---------------|---------------|
| 1. Still In School (KL74=2 or KL78BMO=96 or KL78BYR=9996) | → GO TO KL84A | 5. All Others |
| | | ↓ |

KL84. [CYAQRTH], [CYNAMF CYNAML]

[Are you / Is [she / he]] attending or enrolled in regular school? (Regular school includes high school and schooling that leads to a college or professional school degree.)

1. Yes 5. No → GO TO KL84 END RULE

↓

KL84A. [CYAQRTH], [CYNAMF CYNAML]

[KL84CKPT=STILL IN SCHOOL: Earlier you said [you are / [SP /HEAD] is] still in school.]

What grade or year [are you / is [he / she]] attending?

| | | | | |
|-----------------------------------|---------------------------------------|-----------------|-----------------|-----------------|
| 1. First grade | 2. Second grade | 3. Third grade | 4. Fourth grade | 5. Fifth grade |
| 6. Sixth grade | 7. Seventh grade | 8. Eighth grade | 9. Ninth grade | 10. Tenth grade |
| 11. Eleventh grade | 12. Twelfth grade, "High School", GED | | | |
| 13. 1st year college (freshman) | 14. 2nd year college (sophomore) | | | |
| 15. 3rd year college (junior) | 16. 4th year college (senior) | | | |
| 17. 5th year or higher of college | 18. Post-graduate work | | | |

KL84 END Rule: KL1Ckpt

Returning Spouse/Partner → Repeat SECTION KL For Head;
Then GO TO IMMIG SECTION

Returning Head → GO TO IMMIG SECTION

END KL

END SECTION_KL

Section IMMIG: New Immigrant

[TOC](#)

IMM16. Preloaded Immigrant Status of FU

0. INAP: Not part of 2016 New Immigrant Screener
1. ELIG: Head is immigrant (Head only FU)
2. ELIG: Head only is immigrant (Head + SP FU)
3. ELIG: Head & Spouse/Partner are both immigrants (Head + SP FU)
4. ELIG: Spouse/Partner only is immigrant (Head + SP FU)
5. INELIG: Head & Spouse/Partner are both not immigrants (Head + SP FU)
6. INELIG: Head is not immigrant (Head only FU)

IMM16GRP. Preloaded Immigrant Sample

0. INAP: Not part of 2016 New Immigrant Screener
1. Original Sample (From New Immigrant Screener 2016)
2. Multiplicity Sample (Nominated by Original New Immigrant completed Core 2017 sample)

PYPERSINFO[1].IMM16IND. Preloaded Immigrant Status of Head

0. INAP: Not part of 2016 New Immigrant Screener
1. ELIG: Head Age 20+ /DK/RF & not living in U.S. in 1997
2. ELIG: Head Age<20 & mother not living in U.S. in 1997
3. ELIG: Head Age<20 & father not living in U.S. in 1997
4. ELIG: Head Age<20 & both parents not living in U.S. in 1997
5. INELIG: Head Age 20+/DK/RF & living in U.S. in 1997
6. INELIG: Head Age<20 & both parents living in U.S. in 1997

PYPERSINFO[2].IMM16IND. Preloaded Immigrant Status of Spouse/Partner

0. INAP: Not part of 2016 New Immigrant Screener
1. ELIG: Spouse/Partner Age 20+ /DK/RF & not living in U.S. in 1997
2. ELIG: Spouse/Partner Age<20 & mother not living in U.S. in 1997
3. ELIG: Spouse/Partner Age<20 & father not living in U.S. in 1997
4. ELIG: Spouse/Partner Age<20 & both parents not living in U.S. in 1997
5. INELIG: Spouse/Partner Age 20+/DK/RF & living in U.S. in 1997
6. INELIG: Spouse/Partner Age<20 & both parents living in U.S. in 1997

SECTION_NEWIMMIG

IMMCKPT. CAI Checkpoint: Whether This FU is New Immigrant Sample

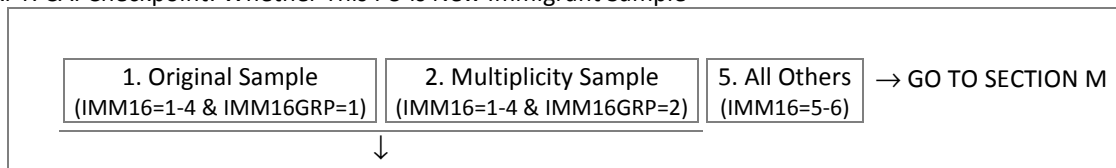

SECTION_NEWIMMIG.IMMDETAIL[1-2] [1]=Current Head, [2]=Current Spouse/Partner

AQSN. AQSN of Current Head (Spouse/Partner)

Language Proficiency

IMM1. [CYNAMF CYNAML]: [CYAQRTH], [CYFUHU], Age [AGEIWDAT]

IF interview conducted in Spanish or other non-English language, DO NOT READ– ENTER [1] to continue

Now I have a few more questions about [HEAD / SP]'s background.

[Have you / Has [HEAD / SP]] ever spoken any language other than English?

1. Yes → GO TO IMM3 5. No



IMM2. [CYNAMF CYNAML]: [CYAQRTH], [CYFUHU], Age [AGEIWDAT]

IF interview conducted in Spanish or other non-English language, DO NOT READ– ENTER [1] to continue
Is any language other than English spoken in [your / [HEAD / SP]'s] home?

1. Yes 5. No → GO TO MULTCKPT



IMM3. [CYNAMF CYNAML]: [CYAQRTH], [CYFUHU], Age [AGEIWDAT]

What languages did [you / [HEAD / SP]] speak in [your / his / her] home with [your / his / her] parents when [you were / [he / she] was] age 10?

- ENTER ALL THAT APPLY

| | | | | | |
|--|------------|-------------|------------|----------------|----------------------|
| 1. English | 2. Spanish | 3. Arabic | 4. Chinese | 5. Creole | 6. Filipino, Tagalog |
| 7. French | 8. Hindi | 9. Japanese | 10. Kru | 11. Korean | 12. Portuguese |
| 13. Russian | 14. Tamil | 15. Telugu | 16. Urdu | 17. Vietnamese | |
| 97. Other-specify (IMM3SPEC. Specify. (String100)) | | | | | |

IMM4. [CYNAMF CYNAML]: [CYAQRTH], [CYFUHU], Age [AGEIWDAT]

What languages [do you / does [HEAD / SP]] currently speak at home?

- ENTER all that apply

| | | | | | |
|--|------------|-------------|------------|----------------|----------------------|
| 1. English | 2. Spanish | 3. Arabic | 4. Chinese | 5. Creole | 6. Filipino, Tagalog |
| 7. French | 8. Hindi | 9. Japanese | 10. Kru | 11. Korean | 12. Portuguese |
| 13. Russian | 14. Tamil | 15. Telugu | 16. Urdu | 17. Vietnamese | |
| 93. [IMM3SPEC] | | | | | |
| 97. Other-specify (IMM4SPEC. Specify. (String100)) | | | | | |

IMM5. [CYNAMF CYNAML]: [CYAQRTH], [CYFUHU], Age [AGEIWDAT]

In the past 12 months, while living in the United States, what languages [have you / has [he / she]] spoken outside of home, for example, while at work?

- ENTER ALL THAT APPLY

| | | | | | |
|--|------------|----------------|------------|----------------|----------------------|
| 1. English | 2. Spanish | 3. Arabic | 4. Chinese | 5. Creole | 6. Filipino, Tagalog |
| 7. French | 8. Hindi | 9. Japanese | 10. Kru | 11. Korean | 12. Portuguese |
| 13. Russian | 14. Tamil | 15. Telugu | 16. Urdu | 17. Vietnamese | |
| 93. [IMM3SPEC] | | 94. [IMM4SPEC] | | | |
| 97. Other-specify (IMM5SPEC. Specify. (String100)) | | | | | |

IMM6. [CYNAMF CYNAML]: [CYAQRTH], [CYFUHU], Age [AGEIWDAT]

What languages [do you / does [HEAD / SP]] speak when [you are / [he / she] is] with friends?

- ENTER all that apply

| | | | | | |
|--|------------|----------------|------------|----------------|----------------------|
| 1. English | 2. Spanish | 3. Arabic | 4. Chinese | 5. Creole | 6. Filipino, Tagalog |
| 7. French | 8. Hindi | 9. Japanese | 10. Kru | 11. Korean | 12. Portuguese |
| 13. Russian | 14. Tamil | 15. Telugu | 16. Urdu | 17. Vietnamese | |
| 93. [IMM3SPEC] | | 94. [IMM4SPEC] | | 95. [IMM5SPEC] | |
| 97. Other-specify (IMM6SPEC. Specify. (String100)) | | | | | |

IMM7CKPT. CAI Checkpoint: Languages Selected at IMM3-IMM6

| | | | | |
|----------------------------------|-----------------------------------|-------------------------------------|---|------------------------------------|
| 1. English plus 1 Non-English | 2. English plus >1 Non-English | 3. No English but >1 Non-English | 4. English Only, or All IMM3-IMM6=DK, RF | 5. No English but 1 Non-English |
| GO TO IMM8 | | ↓ | GO TO IMM9CKPT | GO TO IMM8 |

IMM7. [CYNAMF CYNAML]: [CYAQRTH], [CYFUHU], Age [AGEIWDATE]

[ENGLISH ALSO SELECTED: Aside from English, which / ALL OTHERS: Which] of these languages [do you / does [HEAD / SP]] speak or read most often?

- READ list if needed

Languages Selected at Imm3-Imm6

| | | |
|----------------|----------------|----------------------|
| | 2. Spanish | 3. Arabic |
| 4. Chinese | 5. Creole | 6. Filipino, Tagalog |
| 7. French | | |
| 8. Hindi | 9. Japanese | 10. Kru |
| 11. Korean | | |
| 12. Portuguese | 13. Russian | 14. Tamil |
| 15. Telugu | | |
| 16. Urdu | 17. Vietnamese | |
| 93. [IMM3SPEC] | 94. [IMM4SPEC] | 95. [IMM5SPEC] |
| 96. [IMM6SPEC] | DK/RF | → GO TO IMM9CKPT |

↓

IMM8. [HEAD / SPOUSE/PARTNER]: [CYAQRTH], [CYFUHU], Age [AGEIWDATE]

In general, which language [do you / does [he / she]] speak and read more often, English or [IMM7CKPT=2: [IMM7] / IMM7CKPT=1: [IMM3-IMM6 SELECTION]]?

| | | |
|---|----------------------------|---------------------------------|
| 1. English only | 2. English more frequently | 3. Both languages about equally |
| 4. [[IMM7] / [IMM3-IMM6]] more frequently | | |
| 5. [[IMM7] / [IMM3-IMM6]] only | | |

IMM9CKPT. CAI Checkpoint: Individual Immigrant Status of Head (Spouse/Partner)

| | | |
|-----------------------------|---------------------------------|------------------|
| 1. Immigrant (IMM16IND=1-4) | 5. Not Immigrant (IMM16IND=5-6) | → GO TO MULTCKPT |
| ↓ | | |

IMM9. [CYNAMF CYNAML]: [CYAQRTH], [CYFUHU], Age [AGEIWDATE]

How well [do you / does [HEAD / SP]] understand spoken English? Would you say very well, well, not well, or not at all?

| | | | |
|--------------|---------|-------------|---------------|
| 1. Very well | 2. Well | 3. Not well | 4. Not at all |
|--------------|---------|-------------|---------------|

IMM10. [CYNAMF CYNAML]: [CYAQRTH], [CYFUHU], Age [AGEIWDATE]

How well [do you / does [he / she]] speak English? (Would you say very well, well, not well, or not at all?)

| | | | |
|--------------|---------|-------------|---------------|
| 1. Very well | 2. Well | 3. Not well | 4. Not at all |
|--------------|---------|-------------|---------------|

IMM11. [CYNAMF CYNAML]: [CYAQRTH], [CYFUHU], Age [AGEIWDATE]

How well [do you / does [he / she]] read English? (Would you say very well, well, not well, or not at all?)

| | | | |
|--------------|---------|-------------|---------------|
| 1. Very well | 2. Well | 3. Not well | 4. Not at all |
|--------------|---------|-------------|---------------|

IMM12. [CYNAMF CYNAML]: [CYAQRTH], [CYFUHU], Age [AGEIWDATE]

How well [do you / does [he / she]] write English? (Would you say very well, well, not well, or not at all?)

| | | | |
|--------------|---------|-------------|---------------|
| 1. Very well | 2. Well | 3. Not well | 4. Not at all |
|--------------|---------|-------------|---------------|

Multiplicity Nominator Questions

MULTCKPT. CAI Checkpoint: Whether This FU is Original or Multiplicity Immigrant Sample

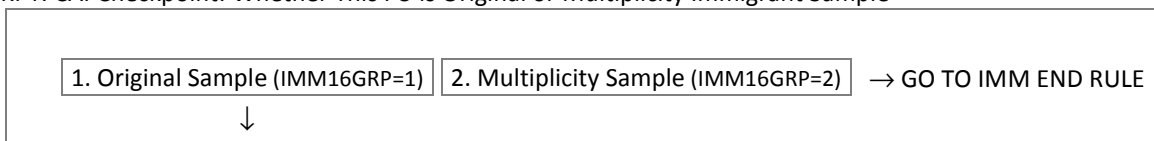

PARCKPT. CAI Checkpoint: Immigrant Status and Birth Year of Head (Spouse/Partner)

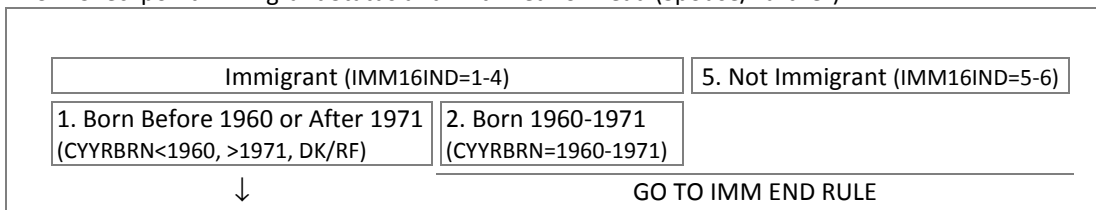
**SECTION_NEWIMMIG.NEWIMMIGDETAIL[1-2].IMMPARENT[1-2]** [1]=Current Head, [2]=Current Spouse/Partner; [1]=Father, [2]=Mother

AQSN. AQSN of Current Head (Spouse/Partner)

PARID. SEQ ID of Parent (1-2)

PAR1CKPTA. CAI Checkpoint: Whether Parent Living in FU

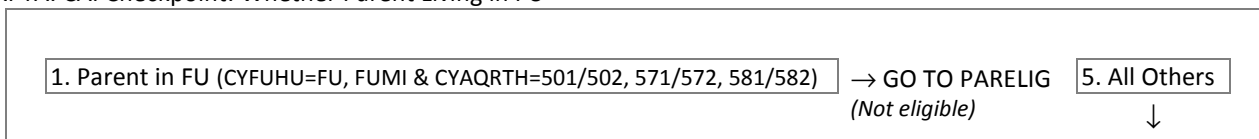

PAR1CKPT. CAI Checkpoint: Where Parent Born

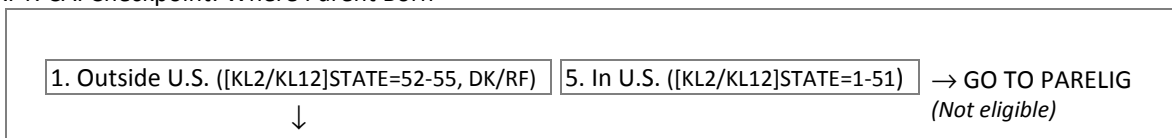

PAR1. [CYNAMF CYNAML]: [CYAQRTH], [CYFUHU], Age [AGEIWDAT]

Next are a few questions about [your / [HEAD / SP]'s] family.

1st ITERATION ONLY: F.E.S. (the Family Economic Study) is a study of how families progress over time and how they change from one generation to the next. Learning about [your / [HEAD's / SP]'s] family members' lives and experiences is an important aspect of F.E.S.

[These next questions are about [your / [HEAD / SP]'s] parents. / (These next questions are about [your / [HEAD / SP]'s] parents.)]

Is [your / [HEAD / SP]'s] [*LOOP 1: father / LOOP 2: mother*] living with [you / [HEAD / SP]] now, living somewhere else in the United States, somewhere outside the United States, or what?

- DEF: "United States" includes the 50 states and the District of Columbia -- it does not include U.S. territories.

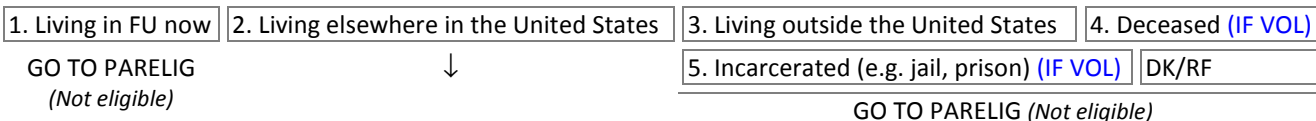

PAR2. [CYNAMF CYNAML]: [CYAQRTH], [CYFUHU], Age [AGEIWDAT]

In what year was [your / [HEAD / SP]'s] [father / mother] born?

1920 - 1984

CHECK FOR PAR2 > H/SP CYRBRN:

Parent's birth year cannot be after [Head's / Spouse/Partner's] birth year ([CYRBRN]).

PAR3 Rule: Parent's Birth Year

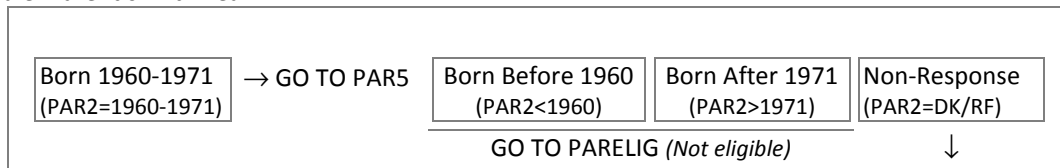

PAR3. [CYNAMF CYNAML]: [CYAQRTH], [CYFUHU], Age [AGEIWDATE]

Could you tell me how old [he / she] is?

- **IF necessary:** What is your best estimate?

30 - 120

CHECK FOR PAR3 < H/SP AGEIWDATE:

Parent cannot be younger than [Head / Spouse/Partner] ([AGEIWDATE]).

PAR4 Rule: Parent's Age

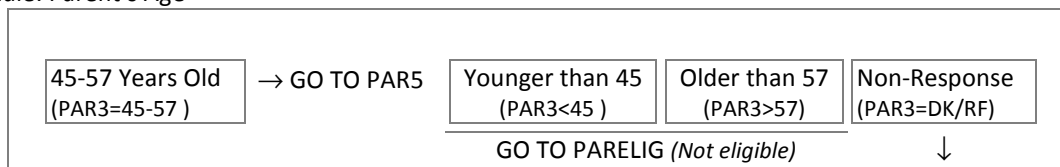

PAR4. [CYNAMF CYNAML]: [CYAQRTH], [CYFUHU], Age [AGEIWDATE]

Is [he / she]...?

- **READ LIST**

| | | | |
|------------------------------|---------------------------|------------------------------|-------|
| 1. Less than 45 years old, | 2. 45 to 57 years old, or | 3. Older than 57? | DK/RF |
| GO TO PARELIG (Not eligible) | ↓ | GO TO PARELIG (Not eligible) | |

PAR5. [CYNAMF CYNAML]: [CYAQRTH], [CYFUHU], Age [AGEIWDATE]

Did [your / [HEAD / SP]'s] [father / mother] live in the United States at any time during 1997?

- **PROBE:** In what year did he (she) move to the United States?
- **DEF:** "United States" includes the 50 states and the District of Columbia -- it does not include U.S. territories.

Approx. age of [father / mother] in 1997: []

Notable events in 1997:

- Bill Clinton was president of U.S. (re-elected in 1996; second inauguration occurred in 1997; impeached in 1998)
- Hong Kong was returned to Chinese rule from British rule
- Diana Princess of Wales is killed in a car crash in Paris
- The movie "Titanic" was released

| | | | | |
|--------|-----------------------------------|-------|-------|-----------------------------------|
| 1. Yes | → GO TO PARELIG (Not eligible) | 5. No | DK/RF | → GO TO PARELIG (Not eligible) |
| | | ↓ | | |

PAR6A. [CYNAMF CYNAML]: [CYAQRTH], [CYFUHU], Age [AGEIWDATE]

What is [your / [HEAD / SP]'s] [father's / mother's] name?

- If R is reluctant to give names, ASK for initials
- Ctrl-D and Ctrl-R not allowed; For DK/RF, type [DK] or [REF]
- ENTER First Name

String 20

- PAR6B. [CYNAMF CYNAML]: [CYAQRTH], [CYFUHU], Age [AGEIWDATE]
 (What is [your / [HEAD / SP]'s] [father's / mother's] name?)
- If R is reluctant to give names, ASK for initials
 - Ctrl-D and Ctrl-R not allowed; For DK/RF, type [DK] or [REF]
 - ENTER Last Name
- String 20

PARELIG. Parent's Multiplicity Eligibility

1. Eligible 5. Not eligible

PARENT END Rule: Whether Father or Mother Loop

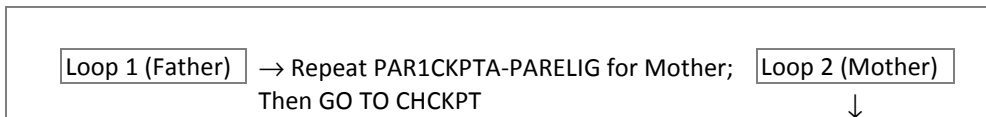

END IMPARENT

CHCKPT. CAI Checkpoint: Whether Eligible Children Reported in Section J



CHILD Rule: Whether Any Eligible Children (CHCOUNT: Count of Children with CHCKPT=1)



SECTION_NEWIMMIG.NEWIMMIGDETAIL[1-2].CHILD[1-20] [1]=Current Head, [2]=Current Spouse/Partner; [1-20]=Which child

AQSN. AQSN of Current Head (Spouse/Partner)

CHID. SEQ ID of Child 1-20

CHJID. Section J ID of Child 1-20

CHILD1. [CYNAMF CYNAML]: [CYAQRTH], [CYFUHU], Age [AGEIWDATE]

Child [CHNAMF CHNAML], Birth year: [CHBYR]

1st ITERATION ONLY: F.E.S. (the Family Economic Study) is a study of how families progress over time and how they change from one generation to the next. Learning about [your / [HEAD's / SP]'s] family members' lives and experiences is an important aspect of F.E.S.

[These next questions are about [your / [HEAD / SP]'s] adult children. / (These next questions are about [your / [HEAD / SP]'s] adult children.)]

[FU MEMBERS W/CYAQRTH=301, 302, 331, 332, 351, 352: ASK R or ENTER [1] if you already know this child is living in the FU now:] Is [Child CHNAMF] living with [you / [HEAD / SP]] now, living somewhere else in the United States, or somewhere outside the United States?

Children of [HEAD / SP] Living in the FU:

[CYNAME], [CYAQRTH], [CYBYEAR]

- DEF: "United States" includes the 50 states and the District of Columbia -- it does not include U.S. territories.

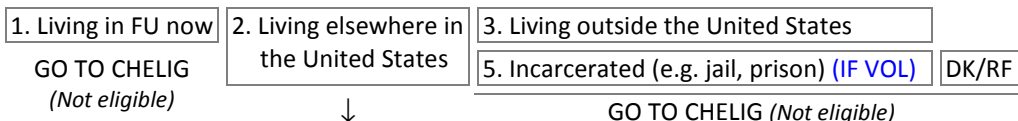

CHILD2. [CYNAMF CYNAML]: [CYAQRTH], [CYFUHU], Age [AGEIWDATE]

Child [CHNAMF CHNAML], Birth year: [CHBYR]

Did [Child CHNAMF] live in the United States at any time during 1997?

- PROBE: In what year did [CHNAMF] move to the United States?
- DEF: "United States" includes the 50 states and the District of Columbia -- it does not include U.S. territories.

Approx. age of child in 1997: []

Notable events in 1997:

- Bill Clinton was president of U.S. (re-elected in 1996; second inauguration occurred in 1997; impeached in 1998)
- Hong Kong was returned to Chinese rule from British rule
- Diana Princess of Wales is killed in a car crash in Paris
- The movie "Titanic" was released

(Not eligible)

(Not eligible)

CHELIG. Child's Multiplicity Eligibility

CHILD END Rule: Whether More Children

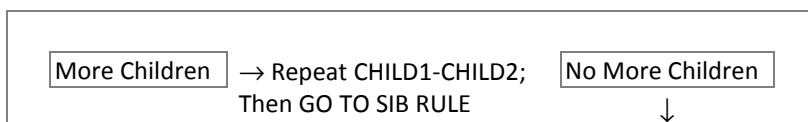

END CHILD

SIB Rule: Whether Any Living Siblings (SIBCOUNT=SISCOUNT + BROCOUNT)

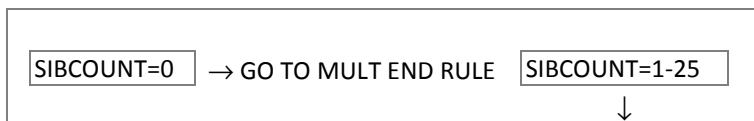

SIB1. [CYNAMF CYNAML]: [CYAQRTH], [CYFUHU], Age [AGEIWDATE]

Number of living siblings reported: [SIBCOUNT]

1st ITERATION ONLY: F.E.S. (the Family Economic Study) is a study of how families progress over time and how they change from one generation to the next. Learning about [your / [HEAD's / SP]'s] family members' lives and experiences is an important aspect of F.E.S.

[These next questions are about [your / [HEAD's / SP]'s] siblings. / (These next questions are about [your / [HEAD's / SP]'s] siblings.)]

You reported that [you have / [HEAD / SP] has] [a living [brother / sister] / [SIB1COUNT] living siblings]. [Was [he / she] / Was (he/she) / How many of these siblings were] born outside of the United States?

- DEF: "United States" includes the 50 states and the District of Columbia -- it does not include U.S. territories.

[SIBCOUNT=1: ENTER [1] for Yes]

[SIBCOUNT=1: ENTER [0] for No]

→ GO TO MULT END RULE → GO TO MULT END RULE

↓

SIB2. [CYNAMF CYNAML]: [CYAQRTH], [CYFUHU], Age [AGEIWDATE]

Number of living siblings born outside of the U.S.: [SIB1]

[Was [he / she] / Was (he/she) / How many of these siblings were] born from 1960 to 1971 (that is, currently age 46 to 57 years old)?

→ GO TO MULT END RULE → GO TO MULT END RULE

↓

SECTION_NEWIMMIG.NEWIMMIGDETAIL[1-2].SIB[1-10] [1]=Current Head, [2]=Current Spouse/Partner; [1-10]=Which sibling
 AQSN. AQSN of Current Head (Spouse/Partner)
 SIBID. SEQ ID of Sibling 1-10

SIB3A. [CYNAMF CYNAML]: [CYAQRTH], [CYFUHU], Age [AGEIWDATE]

Sibling [SIBID] of [SIB2] eligible sibling(s) – born outside of the U.S. and age 46-57 years old

[Let's start with the oldest of these siblings. What / How about the next (oldest) sibling, what] is [[his / her] / (his/her)] name? [FU MEMBERS W/CYAQRTH=401/402, 471/472, 481/482: (Would that be (one of) the sibling(s) living there?)]

[\[Siblings of \[Head / Spouse/Partner\] Living in the FU:](#)

[CYNAML], [CYAQRTH], [CYBYEAR]]

- If R is reluctant to give names, ASK for initials
- Ctrl-D and Ctrl-R not allowed; For DK/RF, type [DK] or [REF]
- ENTER First Name

String 20

SIB3B. [CYNAMF CYNAML]: [CYAQRTH], [CYFUHU], Age [AGEIWDATE]

Sibling [SIBID] of [SIB2] eligible sibling(s) – born outside of the U.S. and age 46-57 years old

[Let's start with the oldest of these siblings. What / How about the next (oldest) sibling, what] is [[his / her]/(his/her)] name? [FU MEMBERS W/CYAQRTH=401/402, 471/472, 481/482: (Would that be (one of) the sibling(s) living there?)]

[\[Siblings of \[Head / Spouse/Partner\] Living in the FU:](#)

[CYNAML], [CYAQRTH], [CYBYEAR]]

- If R is reluctant to give names, ASK for initials
- Ctrl-D and Ctrl-R not allowed; For DK/RF, type [DK] or [REF]
- ENTER Last Name

String 20

SIB4. [CYNAMF CYNAML]: [CYAQRTH], [CYFUHU], Age [AGEIWDATE]

Sibling [SIBID] of [SIB2] eligible sibling(s): [SIB3A SIB3B]

[FU MEMBERS W/CYAQRTH=401/402, 471/472, 481/482: ASK or VERIFY:] In what year was [SIB3A SIB3B] born?

[\[Siblings of \[Head / Spouse/Partner\] Living in the FU:](#)

[CYNAML], [CYAQRTH], [CYBYEAR]]

1920 - 1984

SIB5 Rule: Sibling's Birth Year

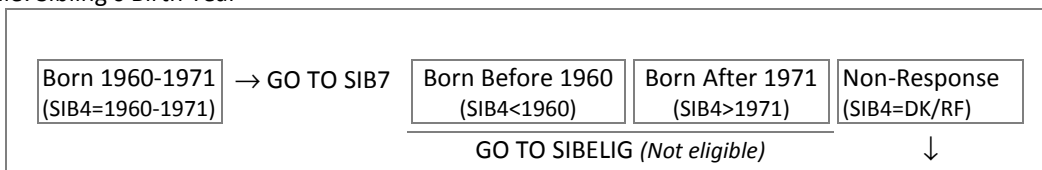

SIB5. [CYNAMF CYNAML]: [CYAQRTH], [CYFUHU], Age [AGEIWDATE]

Sibling [SIBID] of [SIB2] eligible sibling(s): [SIB3A SIB3B]

Could you tell me how old [[he / she] / (he/she)] is?

IF necessary: What is your best estimate?

30 - 120

SIB6 Rule: Sibling's Age

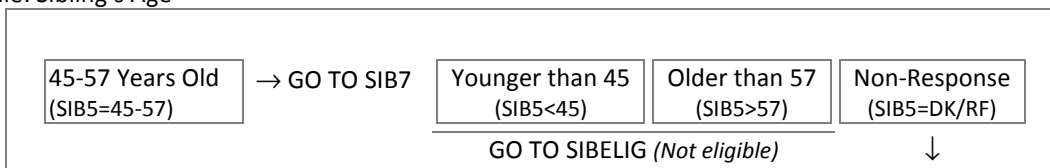

SIB6. [CYNAMF CYNAML]: [CYAQRTH], [CYFUHU], Age [AGEIWDATE]

Sibling [SIBID] of [SIB2] eligible sibling(s): [SIB3A SIB3B]

Is [[he / she] / (he/she)]...?

- READ LIST

1. Less than 45 years old,

2. 45 to 57 years old, or

3. Older than 57?

DK/RF

GO TO SIBELIG (Not eligible)



GO TO SIBELIG (Not eligible)

SIB7. [CYNAMF CYNAML]: [CYAQRTH], [CYFUHU], Age [AGEIWDATE]

Sibling [SIBID] of [SIB2] eligible sibling(s): [SIB3A SIB3B]

[FU MEMBERS W/CYAQRTH=401/402, 471/472, 481/482: ASK R or ENTER [1] if you already know this

sibling is living in the FU now:] Is [SIB3A SIB3B] living with [you / [HEAD / SP]] now, living somewhere else in the United States, or somewhere outside the United States?

[Siblings of [Head / Spouse/Partner] Living in the FU:

[CYNAME], [CYAQRTH], [CYBYEAR]]

- DEF: "United States" includes the 50 states and the District of Columbia -- it does not include U.S. territories

1. Living in FU now

GO TO SIBELIG
(Not eligible)

2. Living elsewhere in
the United States



3. Living outside the United States

5. Incarcerated (e.g. jail, prison) (IF VOL)

DK/RF

GO TO SIBELIG (Not eligible)

SIB8. [CYNAMF CYNAML]: [CYAQRTH], [CYFUHU], Age [AGEIWDATE]

Sibling [SIBID] of [SIB2] eligible sibling(s): [SIB3A SIB3B]

Did [SIB3A SIB3B] live in the United States at any time during 1997?

- PROBE: In what year did (he/she) move to the United States?
- DEF: "United States" includes the 50 states and the District of Columbia -- it does not include U.S. territories.

Approx. age of sibling in 1997: []

Notable events in 1997:

- Bill Clinton was president of U.S. (re-elected in 1996; second inauguration occurred in 1997; impeached in 1998)
- Hong Kong was returned to Chinese rule from British rule
- Diana Princess of Wales is killed in a car crash in Paris
- The movie "Titanic" was released

1. Yes

5. No

DK/RF

(Not eligible)

(Not eligible)

SIBELIG. Sibling's Multiplicity Eligibility

1. Eligible

5. Not eligible

SIBLING END Rule: Whether More Siblings

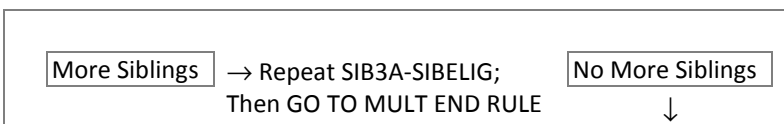

END SIB

MULT End Rule: Whether Any Eligible Multiplicity Persons (MULTCOUNT: Count of PARELIG=1 + CHELIG=1 + SIBELIG=1)

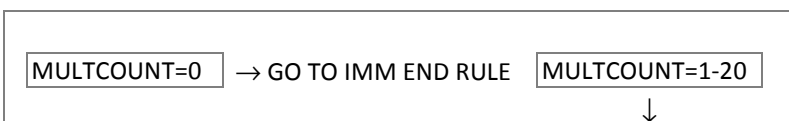

SECTION_NEWIMMIG.NEWIMMIGDETAIL[1-2].GRPMEM[1-20] [1]=Current Head, [2]=Current SP; [1-20]=Which multiplicity person

AQSN. AQSN of Current Head (Spouse/Partner)

MULTID. SEQ ID of Multiplicity Person 1-20

PARID. SEQ ID of Multiplicity Parent 1-20

CHID. SEQ ID of Multiplicity Child 1-20

SIBID. SEQ ID of Multiplicity Sibling 1-10

FNAME. First Name of Multiplicity Person (String 30)

LNAME. Last Name of Multiplicity Person (String 30)

AGE. Age of Multiplicity Person

YRBRN. Birth Year of Multiplicity Person

END GRPMEM**SECTION_NEWIMMIG.NEWIMMIGDETAIL[1-2].GROUP[1-20]** [1]=Current Head, [2]=Current SP; [1-20]=Which multiplicity group

AQSN. AQSN of Current Head (Spouse/Partner)

GROUPIX. SEQ ID of Multiplicity Group 1-20

GROUP[1]. [CYNAMF CYNAML]: [CYAQRTH], [CYFUHU], Age [AGEIWDATE]

New Sample Group 1

1 ELIG PERSON: Only one person is eligible for the new sample

- SELECT that person and [ENTER] to continue

2+ ELIG PERSONS: Do any of people we just spoke about live together in the same household? (Which of these people now live together?)

- READ names if needed
- IF ALL LIVING TOGETHER: Select each person into one group and [ENTER] to finish
- IF NOT LIVING TOGETHER: Select one or more persons into a group and [ENTER] to select the next group

1 – 20. [FNAME LNAME] MULTID List of Multiplicity Persons

GROUP Rule: Whether Eligible Persons Remain

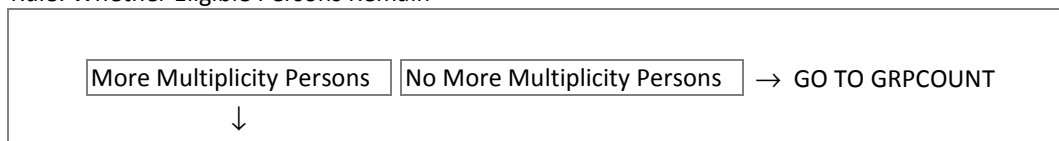

GROUP[2-20]. [CYNAMF CYNAML]: [CYAQRTH], [CYFUHU], Age [AGEIWDATE]

New Sample Group [2-20]

1 ELIG PERSON: Only one person remains

- SELECT that person and [ENTER] to continue

2+ ELIG PERSONS: Do (any of) the other people live together (in the same household)? (Which ones?)

- READ names if needed
- IF ALL LIVING TOGETHER: Select each person into one group and [ENTER] to finish
- IF NOT LIVING TOGETHER: Select one or more persons into a group and [ENTER] to select the next group

1 – 20. [FNAME LNAME] MULTID List of Remaining Multiplicity Persons

END GROUP

GRPCOUNT. Number of Multiplicity Groups

1 - 20

GRPINTRO. [CYNAMF CYNAML]: [CYAQRTH], [CYFUHU], Age [AGEIWDATE]

(F.E.S. (the Family Economic Study) is a study of how families progress over time and how they change from one generation to the next.)

We would like to invite certain members of your family to participate in the F.E.S. They will help us to learn about the experiences of members of the same family who have moved to the United States from other countries, often at different ages and in different years.

We will next ask you about how we can best contact these family members. We will contact them and invite them to join the F.E.S., so that they can share their stories and experiences and be part of this important research. We will also offer them a payment in thanks for their time. They will be able to decide whether or not to participate in the study.

1. Continue 9. Respondent refuses contact with family members → GO TO IMM END RULE



SECTION_NEWIMMIG.NEWIMMIGDETAIL[1-2].GRPCONT[1-20] [1]=Current Head, [2]=Current SP; [1-20]=Which multiplicity group

AQSN. AQSN of Current Head (Spouse/Partner)

GRPID. SEQ ID of Multiplicity Group (GROUPID)

CONTINTRO. [CYNAMF CYNAML]: [CYAQRTH], [CYFUHU], Age [AGEIWDATE]

[First / Next] I'd like to confirm the mailing address and phone number for [[NAME] / the group that includes [LIST OF NAMES]]

- ENTER [1] if R says they can report either address or phone but not both
- Ctrl-D and Ctrl-R not allowed

1. Continue 9. R refuses both address and phone info → GO TO GRPCONT END RULE



NAMF. [CYNAMF CYNAML]: [CYAQRTH], [CYFUHU], Age [AGEIWDATE]

[>1 PERSON IN GROUP: Who should we ask to speak with for this group?]

Persons in Group:

[List of Multiplicity Persons in This Group]

- VERIFY/ENTER name of contact person
- Ctrl-D and Ctrl-R not allowed; For DK/RF type [DK] or [RF]
- ENTER first name

String 30

NAML. [CYNAMF CYNAML]: [CYAQRTH], [CYFUHU], Age [AGEIWDATE]

[>1 PERSON IN GROUP: Who should we ask to speak with for this group?]

Persons in Group:

[List of Multiplicity Persons in This Group]

- VERIFY/ENTER name of contact person
- Ctrl-D and Ctrl-R not allowed; For DK/RF type [DK] or [RF]
- ENTER first name

String 30

LANGUAGE. [CYNAMF CYNAML]: [CYAQRTH], [CYFUHU], Age [AGEIWDATE]

Does [NAMF NAML] primarily speak English, Spanish, or something else?

1. English 2. Spanish 7. Other-specify (LANGSPEC. Specify. (String100))

WTRADDR. [CYNAMF CYNAML]: [CYAQRTH], [CYFUHU], Age [AGEIWDATE]

Address for [NAMF NAML]

What is (his/her/the) mailing address?

- ENTER [9] if R refuses, or R doesn't know the entire address
- Ctrl-D and Ctrl-R not allowed

1. Continue 9. Respondent refuses address → GO TO WTRCELL



INCO. [CYNAMF CYNAML]: [CYAQRTH], [CYFUHU], Age [AGEIWDATE]

Address for [NAMF NAML]

In Care Of

(Is there an "in care of" for the address?)

- If none, PRESS [Enter] to continue
- Ctrl-D and Ctrl-R not allowed; For DK/RF, PRESS [Enter] to continue
- If R says "In jail/prison", TYPE [IN JAIL] here and [DK] for remaining address and phone screens

String 40

ADDR1. [CYNAMF CYNAML]: [CYAQRTH], [CYFUHU], Age [AGEIWDATE]

Address for [NAMF NAML]

Address 1

- If R says the mailing address contains both a street address and PO Box: ENTER street address here (Address 1) and ENTER PO Box in Address 2
- Ctrl-D and Ctrl-R not allowed; For DK/RF type [DK] or [RF]

String 40

APTSTE. [CYNAMF CYNAML]: [CYAQRTH], [CYFUHU], Age [AGEIWDATE]

Address for [NAMF NAML]

Apartment/Suite

- If none, PRESS [Enter] to continue
- Ctrl-D and Ctrl-R not allowed; For DK/RF, PRESS [Enter] to continue

String 10

ADDR2. [CYNAMF CYNAML]: [CYAQRTH], [CYFUHU], Age [AGEIWDATE]

Address for [NAMF NAML]

Address 2

- If R says the mailing address contains both a street address and PO Box: ENTER PO Box here (Address 2)
- If none, PRESS [Enter] to continue
- Ctrl-D and Ctrl-R not allowed; For DK/RF, PRESS [Enter] to continue

String 40

CITY. [CYNAMF CYNAML]: [CYAQRTH], [CYFUHU], Age [AGEIWDATE]

Address for [NAMF NAML]

City

- Ctrl-D and Ctrl-R not allowed; For DK/RF type [DK] or [RF]

String 40

STATE. [CYNAMF CYNAML]: [CYAQRTH], [CYFUHU], Age [AGEIWDATE]

Address for [NAMF NAML]

State

- Start typing the name of the State to bring up the look-up list

String 30; String 4 *Foreign Country Not Allowed*

ZIP. [CYNAMF CYNAML]: [CYAQRTH], [CYFUHU], Age [AGEIWDATE]

Address for [NAMF NAML]

Zip Code

- Ctrl-D and Ctrl-R not allowed; For DK/RF ENTER all [0]'s

WTRCELL. [CYNAMF CYNAML]: [CYAQRTH], [CYFUHU], Age [AGEIWDATE]

Phone for [NAMF NAML]

Does [NAMF] ([NAML]) have a cell phone where we can reach (him/her)?

- ENTER [9] if R refuses or doesn't know the phone number
- Ctrl-D and Ctrl-R not allowed

1. Yes 5. No → GO TO WTRHOME 9. Respondent refuses Phone → GO TO GRPCONT END RULE

↓

CELLPHONE. [CYNAMF CYNAML]: [CYAQRTH], [CYFUHU], Age [AGEIWDATE]

Phone for [NAMF NAML]

Cell Area Code and Telephone Number

What is the area code and phone number?

- Ctrl-D and Ctrl-R not allowed; For DK/RF, GO BACK and ENTER [9] at WtrCell

CARRIER. [CYNAMF CYNAML]: [CYAQRTH], [CYFUHU], Age [AGEIWDATE]

Phone for [NAMF NAML]

Which carrier does that cell phone use?

| | | | | |
|--|-----------------------------------|--|----------------------------------|--|
| <input type="text"/> 1. Alltel | <input type="text"/> 2. AT&T | <input type="text"/> 3. Boost Mobile | <input type="text"/> 4. Cricket | <input type="text"/> 5. MetroPCS |
| <input type="text"/> 6. Nextel | <input type="text"/> 7. Ptel | <input type="text"/> 8. Qwest | <input type="text"/> 9. Sprint | <input type="text"/> 10. Suncom |
| <input type="text"/> 11. T-Mobile | <input type="text"/> 12. Tracfone | <input type="text"/> 13. U.S. Cellular | <input type="text"/> 14. Verizon | <input type="text"/> 15. Virgin Mobile |
| <input type="text"/> 97. Other-Specify (CARRIERSPEC. Specify. (String 20)) | | | | |

WTRHOME. [CYNAMF CYNAML]: [CYAQRTH], [CYFUHU], Age [AGEIWDATE]

Phone for [NAMF NAML]

Does [NAMF] ([NAML]) have a home phone (where we can reach (him/her))?

1. Yes 5. No → GO TO WTROTHER

↓

HOMEPHONE. [CYNAMF CYNAML]: [CYAQRTH], [CYFUHU], Age [AGEIWDATE]

Phone for [NAMF NAML]

Home Phone Area Code and Telephone Number

What is the area code and phone number?

- Ctrl-D and Ctrl-R not allowed; For DK/RF, GO BACK and ENTER [5] at WtrHome

WTROTHER. [CYNAMF CYNAML]: [CYAQRTH], [CYFUHU], Age [AGEIWDAT]E

Phone for [NAMF NAML]

Does [NAMF] ([NAML]) have any other phone (where we can reach (him/her))?

1. Yes 5. No → GO TO GRPCONT END RULE

↓

OTHERPHONE. [CYNAMF CYNAML]: [CYAQRTH], [CYFUHU], Age [AGEIWDAT]E

Phone for [NAMF NAML]

Other Phone Area Code and Telephone Number

What is the area code and phone number?

- Ctrl-D and Ctrl-R not allowed; For DK/RF, GO BACK and ENTER [5] at WtrOther

(_ _) _ _ - _ _ _ _

GRPCONT END Rule: Whether More Multiplicity Groups

| | | |
|--------------------------------------|---|---|
| <input type="checkbox"/> More Groups | → Repeat CONTINTRO-OTHERPHONE; Then GO TO IMM END RULE | <input type="checkbox"/> No More Groups |
| | | ↓ |

END GRPCONT
END NEWIMMIGDETAIL

IMM END Rule: Whether Spouse/Partner in FU

| | | |
|---|---|---|
| <input type="checkbox"/> Spouse/Partner (CYFUHU=FU, FUMI & CYAQRTH=201-222) | → Repeat IMMIG SECTION; Then GO TO SECTION M | <input type="checkbox"/> No Spouse/Partner GO TO SECTION M |
|---|---|---|

END NEWIMMIG

Section M: Philanthropy

[TOC](#)

SECTION_M

M0 Rule: Respondent

| | |
|---|---------------------------------|
| R=Head, Spouse/Partner (RESPONDENT=1, 2, 3) | R=OFUM, Proxy (RESPONDENT=4, 7) |
| ↓ | GO TO INTERVIEW END |

Donations

M1_INTRO. Next, we will be talking about donations to charities that serve a variety of purposes such as religious activity, helping people in need, health care and medical research, education, arts, environment, and international aid.

Charitable organizations include religious or non-profit organizations that help those in need or that serve and support the public interest. They range in size from national organizations like the United Way and the American Red Cross down to local community organizations. Political contributions are not included.

Donations include money, assets, property or goods, whether made directly to the organization, through payroll deduction, or on the internet.

- ENTER [1] to continue

1. Continue

M1. During [PYEAR], did you [or anyone in your family] donate money, assets, property or goods, with a combined value of more than \$25 to religious or charitable organizations?

1. Yes 5. No → GO TO M56A

↓

M2. Did you make any donations specifically for religious purposes or spiritual development, for example to a church, synagogue, mosque, TV or radio ministry? Please do not include donations to schools, hospitals, and other charities run by religious organizations. I will be asking you about those donations next.

1. Yes 5. No → GO TO M3

↓

M2A. How much was that in [PYEAR]? (Altogether, what was the total dollar value of all donations you [and your family] made in [PYEAR] towards religious purposes?)

\$ 1 – 999,997

M3. [*M2=YES*: Not counting the donations you just told me about, (during [PYEAR],) / *ALL OTHERS*: (During [PYEAR],)] did you [or anyone in your family] donate to any organization that served a combination of purposes? For example, the United Way, the United Jewish Appeal, the Catholic Charities, or your local community foundation?

1. Yes 5. No → GO TO M4

↓

M3A. How much was that (in [PYEAR])? (Altogether, what was the total dollar value of all donations you [and your family] made in [PYEAR] towards combined purpose funds?)

\$ 1 – 999,997

M4. ([M2 OR M3=YES: Not counting the donations you just told me about, did you / ALL OTHERS: Did you] [or anyone in your family] make any donations (during [PYEAR])) to organizations that help people in need of food, shelter, or other basic necessities?

1. Yes 5. No → GO TO M5



M4A. How much was that (in [PYEAR])? (What was the total dollar value of all donations you [and your family] made in [PYEAR] to organizations that help people in need of basic necessities?)

\$ 1 – 99,997

M5. ([ANY M2-M4=YES: Not counting the donations you just told me about, did you / ALL OTHERS: Did you] [or anyone in your family] make donations (during [PYEAR])) to health care or medical research organizations? For example, to hospitals, nursing homes, mental health facilities, cancer, heart and lung associations, or telethons?

1. Yes 5. No → GO TO M6



M5A. How much was that (in [PYEAR])? (What was the total dollar value of all donations you [and your family] made in [PYEAR] towards health care or medical research organizations?)

\$ 1 – 99,997

M6. ([ANY M2-M5=YES: Not counting the donations you just told me about, did you / ALL OTHERS: Did you] [or anyone in your family] make donations (during [PYEAR])) towards educational purposes? For example, to colleges, grade schools, PTAs, libraries, or scholarship funds? Please do not include direct tuition payments for you or other family members.

1. Yes 5. No → GO TO M7



M6A. How much was that (in [PYEAR])? (What was the total dollar value of all donations you [and your family] made in [PYEAR] towards educational purposes?)

\$ 1 – 99,997

M7. ([ANY M2-M6=YES: Not counting the donations you just told me about, (during [PYEAR],) / ALL OTHERS: During [PYEAR],) did you [or anyone in your family] make donations) to organizations that provide youth or family services? Such as to scouting, boys' and girls' clubs, sports leagues, Big Brothers or Sisters, foster care, or family counseling?

1. Yes 5. No → GO TO M8



M7A. How much was that (in [PYEAR])? (What was the total dollar value of all donations you [and your family] made in [PYEAR] towards youth and family services purposes?)

\$ 1 – 99,997

M8. ([ANY M2-M7=YES: Not counting the donations you just told me about, (during [PYEAR],) / ALL OTHERS: (During [PYEAR],) did you [or anyone in your family] make donations) to organizations that support or promote the arts, culture, or ethnic awareness? Such as, to a museum, theatre, orchestra, public broadcasting, or ethnic cultural awareness?

1. Yes 5. No → GO TO M9



M8A. How much was that (in [PYEAR])? (What was the total dollar value of all donations you [and your family] made in [PYEAR] towards the arts, culture, or ethnic awareness?)

\$ 1 – 99,997

M9. ([*ANY M2-M8=YES*: Not counting the donations you just told me about, (during [PYEAR],) / *ALL OTHERS*: (During [PYEAR],)] did you [or anyone in your family] make donations) to organizations that improve neighborhoods and communities? Such as, to community associations or service clubs?

1. Yes 5. No → GO TO M10



M9A. How much was that (in [PYEAR])? (What was the total dollar value of all donations you [and your family] made in [PYEAR] towards improving neighborhoods and communities?)

M10. ([*ANY M2-M9=YES*: Not counting the donations you just told me about, (during [PYEAR],) / *ALL OTHERS*: (During [PYEAR],)] did you [or anyone in your family] make donations) to organizations that preserve the environment? Such as, for conservation efforts, animal protection, or parks?

1. Yes 5. No → GO TO M11



M10A. How much was that (in [PYEAR])? (What was the total dollar value of all donations you [and your family] made in [PYEAR] towards preserving the environment?)

M11. ([*ANY M2-M10=YES*: Not counting the donations you just told me about, (during [PYEAR],) / *ALL OTHERS*: (During [PYEAR],)] did you [or anyone in your family] make donations) to organizations that provide international aid or promote world peace? Such as, international children's funds, disaster relief, or human rights?

1. Yes 5. No → GO TO M12



M11A. How much was that (in [PYEAR])? (What was the total dollar value of all donations you [and your family] made in [PYEAR] towards providing international aid or promoting world peace?)

M12. ([*ANY M2-M11=YES*: Not counting the donations you just told me about, (during [PYEAR],) / *ALL OTHERS*: (During [PYEAR],)] did you [or anyone in your family] make donations of) money, assets, or property to charitable organizations with purposes other than those we just talked about?

1. Yes 5. No → GO TO M56A



M12A. What was the main purpose or cause supported by that organization?

- **PROBE:** Please tell me a little more about that. What does this organization do?

M12B. How much was that (in [PYEAR])? (What was the total dollar value of all donations you [and your family] made in [PYEAR] towards (this / these) last purpose(s)?)

Religious Attendance

M56A_AQSN. AQSN of Current Head

M57A_AQSN. AQSN of Current Spouse/Partner

M56A. [CYNAMF CYNAML], [CYAQRTH], [CYFUHU], Age: [AGEIWDATE], [(Respondent)]

And finally, during the year [PYEAR], on average, how often did [you / [HEAD]] go to religious services?

- ENTER amount here, then ENTER unit of time on next screen (Day, Week, Two weeks, Month, Year)

→ GO TO M57CKPT → GO TO M57CKPT



M56B. [CYNAMF CYNAML], [CYAQRTH], [CYFUHU], Age: [AGEIWDATE], [(Respondent)]

The amount entered is: [M56A] per ____

- SELECT the unit of time below

M57CKPT. CAI Checkpoint: Whether Spouse/Partner in FU

→ GO TO INTERVIEW END



M57A. [CYNAMF CYNAML], [CYAQRTH], [CYFUHU], Age: [AGEIWDATE], [(Respondent)]

During the year [PYEAR], on average, how often did [you / [SP]] go to religious services?

- ENTER amount here, then ENTER unit of time on next screen (Day, Week, Two weeks, Month, Year)

→ GO TO INTERVIEW END → GO TO INTERVIEW END



M57B. [CYNAMF CYNAML], [CYAQRTH], [CYFUHU], Age: [AGEIWDATE], [(Respondent)]

The amount entered is: [M57A] per ____

- SELECT the unit of time below

END SECTION_M

Interview End

[TOC](#)

IWCLOSE

Q1. Thank you, that concludes the interview portion of my call. Now, I just need to verify some information that will help us contact [you / this family] in the future.

- [ENTER \[1\] to continue](#)

1. Continue

END IWCLOSE

Address Updates and Payment

[TOC](#)

ADDRPAYMENT

WTRPREPAID. Whether interview was prepaid

1. Interview was prepaid 5. Interview was not prepaid

WtrPrePaid (tSample_line.vExt_026) = 5

If payment is prepaid, SRO data manager updates WtrPrePaid (tSample_line.vExt_026) = 1

AMTPREPAID. Prepayment Amount

AmtPrePaid (tSample_line.vExt_027) = \$0.00

If payment is prepaid, SRO data manager updates AmtPrePaid (tSample_line.vExt_027) = \$ amount of prepayment

PAYMENT. Standard Payment Amount

Payment (tSample_line.vExt_028) = 70.00 or 100.00

If standard payment is increased and IWCLOSE.Q1<>EMPTY (meaning a suspended interview has not progressed to this section yet), SRO data manager updates Payment (tSample_line.vExt_028) = new \$ amount of standard payment.

IWPAYWHO. Who Receives Interview Payment

1. Head 2. Spouse 3. Partner 4. OFUM 5. Declined 6. Other payee 7. Proxy 8. None; Prepay okay

IWPAYAMT. Amount of Interview Payment

IW not prepaid-Declined; IW prepaid-Prepay okay; IW prepaid-Prepay not okay or not rec'd-Declined

IW not prepaid-Standard check or money order (+ cell phone)

IW not prepaid-Cash payment (+ cell phone); IW prepaid-Prepay not okay or not rec'd- Cash payment (+ cell phone)

IW not prepaid-Non-standard payment (+ cell phone); IW prepaid-Prepay not okay or not rec'd-Additional payment needed (+ cell phone)

IWPAYMODE. Mode of Interview Payment

1. Check IW not prepaid-Standard check or Non-standard payment; IW prepaid-Prepay not okay or not rec'd- Additional payment

2. Money order IW not prepaid-Standard money order

4. Declined IW not prepaid-Declined; IW prepaid-Prepay not okay or not rec'd-Declined

5. Cash IW not prepaid-Cash payment; IW prepaid-Prepay not okay or not rec'd-Cash payment

7. None; Prepay okay IW prepaid-Prepay okay

RPAY1. CAI Checkpoint: Who Is R

1. R=Head, SP, OFUM (RESPONDENT=1-4) → GO TO RPAY2A 2. R=Proxy (RESPONDENT=7)



RPAY1A. You will receive \$[PAYMENT] from The University of Michigan in appreciation of your help. In order for the University to send you a check or other correspondence, I must make sure that I have your correct name and mailing address.

- ENTER [1] to continue

1. Continue

ADDRPAYMENT.PROXYADDR

ADDRTYPE. Which Address

1. Proxy

TITLE. What is your complete name and mailing address?

Title -- e.g. "Mr", "Mrs", "Ms", "Miss", "Dr"

- If no title, PRESS [Enter] to continue
- Ctrl-D and Ctrl-R not allowed; For DK/RF, PRESS [Enter] to continue

String 6

NAMF. First Name

- Ctrl-D and Ctrl-R not allowed; For DK/RF type [DK] or [RF]

String 20

NAMM. Middle Name

- Ask for Middle Name but do not probe DK or RF
- If none, PRESS [Enter] to continue
- Ctrl-D and Ctrl-R not allowed; For DK/RF, PRESS [Enter] to continue

String 20

NAML. Last Name

- Ctrl-D and Ctrl-R not allowed; For DK/RF type [DK] or [RF]

String 20

SUFFIX. Suffix -- e.g. "Sr", "Jr"

- If none, PRESS [Enter] to continue
- Ctrl-D and Ctrl-R not allowed; For DK/RF, PRESS [Enter] to continue

String 20

INCO. Is there an "in care of" for this address?

In Care Of

- If none, PRESS [Enter] to continue
- Ctrl-D and Ctrl-R not allowed; For DK/RF, PRESS [Enter] to continue

String 40

ADDR1. Address 1

- If R says the mailing address contains both a street address and PO Box: ENTER street address here (Address 1) and ENTER PO Box in Address 2
- Ctrl-D and Ctrl-R not allowed; For DK/RF type [DK] or [RF]

String 40

APTSTE. Apt/Suite

- If none, PRESS [Enter] to continue
- Ctrl-D and Ctrl-R not allowed; For DK/RF, PRESS [Enter] to continue

String 10

ADDR2. Address 2

- If R says the mailing address contains both a street address and PO Box: ENTER PO Box here (Address 2)
- If none, PRESS [Enter] to continue
- Ctrl-D and Ctrl-R not allowed; For DK/RF, PRESS [Enter] to continue

String 40

CITY. City

- Ctrl-D and Ctrl-R not allowed; For DK/RF type [DK] or [RF]

String 40

STATE. State

- Start typing the name of the State to bring up the look-up list
- If foreign country, ENTER [FOR] to select "Foreign Country"

String 30; String 4

ZIP. Zip Code

- If foreign country, ENTER all [0]'s
- Ctrl-D and Ctrl-R not allowed; For DK/RF ENTER all [0]'s

COUNTRY. Country if different from USA

- Start typing the name of the Foreign Country to bring up the look-up list

String 30; String 2

END PROXYADDR

ADDRPAYMENT.PROXYPH

ADDRTYPE. Which Phone

WTRCELL. Do you have a cell phone?

- Do NOT ask but ENTER [1] if you know R is using a cell phone
- Ctrl-D and Ctrl-R not allowed; For DK/RF ENTER [5]

 → GO TO WTRHOMECELLPH. [Cell Phone - Area Code and Telephone Number](#)

What is the area code and phone number?

- If foreign phone, PRESS [ENTER] to go to foreign phone field
- Ctrl-D and Ctrl-R not allowed; For DK/RF, GO BACK and ENTER [5] at WtrCell

 → GO TO CARRIERCELLFOR. [Cell Phone - Foreign Number](#)

(What is the area code and phone number?)

- Ctrl-D and Ctrl-R not allowed; For DK/RF, GO BACK and ENTER [5] at WtrCell

CARRIER. [Cell Phone - Carrier](#)

Which carrier does your cell phone use?

| | | | | | | |
|--|---|--|---|---|--|--|
| <input type="text" value="1. Alltel"/> | <input type="text" value="2. AT&T"/> | <input type="text" value="3. Boost Mobile"/> | <input type="text" value="4. Cricket"/> | <input type="text" value="5. MetroPCS"/> | <input type="text" value="6. Nextel"/> | <input type="text" value="7. Ptel"/> |
| <input type="text" value="8. Qwest"/> | <input type="text" value="9. Sprint"/> | <input type="text" value="10. Suncom"/> | <input type="text" value="11. T-Mobile"/> | <input type="text" value="12. Tracfone"/> | <input type="text" value="13. U.S. Cellular"/> | <input type="text" value="14. Verizon"/> |
| <input type="text" value="15. Virgin Mobile"/> | <input type="text" value="97. Other - Specify (CARRIERSPEC. Specify cell phone carrier. (String 20))"/> | | | | | |

WTRHOME. Do you have a home phone?

- Ctrl-D and Ctrl-R not allowed; For DK/RF ENTER [5]

 → GO TO WTROTHERHOMEPH. [Home Phone - Area Code and Telephone Number](#)

What is the area code and phone number?

- If foreign phone, PRESS [ENTER] to go to foreign phone field
- Ctrl-D and Ctrl-R not allowed; For DK/RF, GO BACK and ENTER [5] at WtrHome

 → GO TO WTROTHERHOMEFOR. [Home Phone - Foreign Number](#)

(What is the area code and phone number?)

- Ctrl-D and Ctrl-R not allowed; For DK/RF, GO BACK and ENTER [5] at WtrHome

WTROTHER. Is there any other phone where we can reach you?

- Ctrl-D and Ctrl-R not allowed; For DK/RF ENTER [5]

1. Yes 5. No → GO TO RPAY1FF



OTHPH. Other Phone - Area Code and Telephone Number

What is the area code and phone number?

- If foreign phone, PRESS [ENTER] to go to foreign phone field
- Ctrl-D and Ctrl-R not allowed; For DK/RF, GO BACK and ENTER [5] at WtrOther

[ENTER] (_ _) _ _ - _ _ _ → GO TO OTHEXT



OTHFOR. Other Phone - Foreign Number

(What is the area code and phone number?)

- Ctrl-D and Ctrl-R not allowed; For DK/RF, GO BACK and ENTER [5] at WtrOther

String 20

OTHEXT. Other Phone - Extension

Is there an extension?

- If none, PRESS [Enter] to continue
- Ctrl-D and Ctrl-R not allowed; For DK/RF, PRESS [Enter] to continue

String 20

END PROXYPH

RPAY1FF. What is your relationship to [HEAD]?

| | | | | | |
|-------------------|------------|---|-----------------|------------|-------------------|
| 1. Mother | 2. Father | 3. Son | 4. Daughter | 5. Sister | 6. Brother |
| 7. Aunt | 8. Uncle | 9. Grandmother | 10. Grandfather | 11. Friend | 12. Father-in-law |
| 13. Mother-in-law | 14. Cousin | 97. Other-Specify (RPAY1FFSPEC. Specify. (String 50)) | | | |

RPAY1G. Is there an email address where we can contact you?

1. Yes 5. No → GO TO RAY2A



RPAY1H. (What is that e-mail address?)

- ENTER email address, then READ BACK and VERIFY with Respondent
- Ctrl-D and Ctrl-R not allowed; For DK/RF go back and ENTER [Ctrl-D, Ctrl-R] at previous question

String 50

RAY2A. *WTRPREPAID=5*: [*R=HEAD, SP, OFUM*: You will receive \$[PAYMENT] from the University of Michigan in appreciation of your help. In order for the University to send you a check or other correspondence, I must make sure that I have your correct name and mailing address. / *R=PROXY*: I would also like to have the correct name and address for [HEAD].] / *R=PROXY*: I would also like to have the correct name and address for [HEAD].]

- Verify/Update/Change (R's/Head's) mailing address and phone number
- ENTER [1] to continue

WTRPREPAID=1: This interview was PREPAID

[*R=HEAD, SP, OFUM*: In order for the University to keep in touch with you, I must make sure that I have your correct name and mailing address. / *R=PROXY*: I would also like to have the correct name and address for [HEAD].]

- Verify/Update/Change (R's/Head's) mailing address and phone number
- ENTER [1] to continue

1. Continue

RP2AQS. AQS of Respondent (For R=Head, Spouse/Partner, or OFUM)

ADDRPAYMENT.RMAILADDR (Prefilled with RespondentAddr preload)**ADDRTYPE.** Which Address

2. R (or Head)

TITLE. Title -- e.g. "Mr", "Mrs", "Ms", "Miss", "Dr"

- If no title, PRESS [Enter] to continue
- Ctrl-D and Ctrl-R not allowed; For DK/RF, PRESS [Enter] to continue
- VERIFY Title of [Respondent / Head]: [CYNAMF CYNAMM CYNAML] ([CYAQRTH])

String 6

NAMF. First Name

- Ctrl-D and Ctrl-R not allowed; For DK/RF, type [DK] or [RF]
- VERIFY First Name of [Respondent / Head]: [CYNAMF CYNAMM CYNAML] ([CYAQRTH])

String 20

NAMM. Middle Name

- Ask for Middle Name but do not probe DK or RF
- If none, PRESS [Enter] to continue
- Ctrl-D and Ctrl-R not allowed; For DK/RF, PRESS [Enter] to continue
- VERIFY Middle Name of [Respondent / Head]: [CYNAMF CYNAMM CYNAML] ([CYAQRTH])

String 20

NAML. Last Name

- Ctrl-D and Ctrl-R not allowed; For DK/RF type [DK] or [RF]
- VERIFY Last Name of [Respondent / Head]: [CYNAMF CYNAMM CYNAML] ([CYAQRTH])

String 20

SUFFIX. Suffix -- e.g. "Sr", "Jr"

- If none, PRESS [Enter] to continue
- Ctrl-D and Ctrl-R not allowed; For DK/RF, PRESS [Enter] to continue
- VERIFY Suffix of [Respondent / Head]: [CYNAMF CYNAMM CYNAML] ([CYAQRTH])

String 20

INCO. In Care Of

[R=HEAD, SP, OFUM: Now for your complete mailing address, as you would like it to appear on all correspondence from us. First, is there an "in care of" for your address? / R=PROXY: Now for [HEAD]'s complete mailing address. First, is there an "in care of" for the address?]

- If none, PRESS [Enter] to continue
- Ctrl-D and Ctrl-R not allowed; For DK/RF, PRESS [Enter] to continue

String 40

ADDR1. Address 1

- IF R says the mailing address contains both a street address and PO Box: ENTER street address here (Address 1) and ENTER PO Box in Address 2
- Ctrl-D and Ctrl-R not allowed; For DK/RF type [DK] or [RF]

String 40

APTSTE. Apt/Suite

- If none, PRESS [Enter] to continue
- Ctrl-D and Ctrl-R not allowed; For DK/RF, PRESS [Enter] to continue

String 10

ADDR2. Address 2

- IF R says the mailing address contains both a street address and PO Box: ENTER PO Box here (Address 2)
- If none, PRESS [Enter] to continue
- Ctrl-D and Ctrl-R not allowed; For DK/RF, PRESS [Enter] to continue

String 40

CITY. City

- Ctrl-D and Ctrl-R not allowed; For DK/RF type [DK] or [RF]

String 40

STATE. State

- Start typing the name of the State to bring up the look-up list
- If foreign country, ENTER [FOR] to select "Foreign Country"

String 30; String 4

ZIP. Zip Code

- If foreign country, ENTER all [0]'s
- Ctrl-D and Ctrl-R not allowed; For DK/RF ENTER all [0]'s

----- - -----

COUNTRY. Country if different from USA

- Start typing the name of the Foreign Country to bring up the look-up list

String 30; String 2

END RMAILADDR

ADDRPAYMENT.RPHONE (Prefilled with RespondentAddr or NewPreload preload)

ADDRTYPE. Which Phone

AQSN. AQSN of R (R=Head, Spouse/Partner, OFUM) or Head (R=Proxy)

WTRCELL. [Do you / Does [HEAD]] have a cell phone?

- [R=HEAD, SP, OFUM: Do NOT ask but ENTER [1] if you know R is using a cell phone]
- Ctrl-D and Ctrl-R not allowed; For DK/RF ENTER [5]

→ GO TO WTRHOME

↓

CELLPH. Cell Phone - Area Code and Telephone Number

What is the area code and phone number?

- ASK; or CONFIRM if phone number has been prelisted and this is the same [R=HEAD, SP, OFUM: Respondent / R=PROXY: Head] as [P2YEAR]
- If foreign phone, PRESS [ENTER] to go to foreign phone field
- Ctrl-D and Ctrl-R not allowed; For DK/RF, GO BACK and ENTER [5] at WtrCell

→ GO TO CARRIER

↓

CELLFOR. Cell Phone - Foreign Number

(What is the area code and phone number?)

- ASK; or CONFIRM if phone number has been prelisted and this is the same [Respondent / Head] as [P2YEAR]
- Ctrl-D and Ctrl-R not allowed; For DK/RF, GO BACK and ENTER [5] at WtrCell

CARRIER. Cell Phone - Carrier

Which carrier does [your / his / her] cell phone use?

| | | | | | | |
|--|---|--|---|---|--|--|
| <input type="text" value="1. Alltel"/> | <input type="text" value="2. AT&T"/> | <input type="text" value="3. Boost Mobile"/> | <input type="text" value="4. Cricket"/> | <input type="text" value="5. MetroPCS"/> | <input type="text" value="6. Nextel"/> | <input type="text" value="7. Ptel"/> |
| <input type="text" value="8. Qwest"/> | <input type="text" value="9. Sprint"/> | <input type="text" value="10. Suncom"/> | <input type="text" value="11. T-Mobile"/> | <input type="text" value="12. Tracfone"/> | <input type="text" value="13. U.S. Cellular"/> | <input type="text" value="14. Verizon"/> |
| <input type="text" value="15. Virgin Mobile"/> | <input type="text" value="97. Other - Specify (CARRIERSPEC. Specify cell phone carrier. (String 20))"/> | | | | | |

WTRHOME. [Do you / Does [he / she]] have a home phone?

- Ctrl-D and Ctrl-R not allowed; For DK/RF ENTER [5]

→ GO TO OTHERCKPT

↓

HOMEPH. Home Phone - Area Code and Telephone Number

What is the area code and phone number?

- ASK; or CONFIRM if phone number has been prelisted and this is the same [Respondent / Head] as [P2YEAR]
- If foreign phone, PRESS [ENTER] to go to foreign phone field
- Ctrl-D and Ctrl-R not allowed; For DK/RF, GO BACK and ENTER [5] at WtrHome

→ GO TO OTHERCKPT

↓

HOMEFOR. Home Phone - Foreign Number

(What is the area code and phone number?)

- ASK; or CONFIRM if phone number has been prelisted and this is the same [Respondent / Head] as [P2YEAR]
- Ctrl-D and Ctrl-R not allowed; For DK/RF, GO BACK and ENTER [5] at WtrHome

OTHERCKPT. CAI Checkpoint: Respondent

| | | |
|--|---------------------------|--------------------|
| 1. R=Head, Spouse/Partner, OFUM (RESPONDENT=1-4) | 2. R=Proxy (RESPONDENT=7) | → GO TO RPAY2GCKPT |
| ↓ | | |

WTROTHER. Is there any other phone where we can reach you?

- Ctrl-D and Ctrl-R not allowed; For DK/RF ENTER [5]

1. Yes | 5. No → GO TO HSPCKPT

↓

OTHPH. Other Phone - Area Code and Telephone Number

What is the area code and phone number?

- ASK; or CONFIRM if phone number has been prelisted and this is the same [Respondent / Head] as [P2YEAR]
- If foreign phone, PRESS [ENTER] to go to foreign phone field
- Ctrl-D and Ctrl-R not allowed; For DK/RF, GO BACK and ENTER [5] at WtrOther

[ENTER] (_ _) _ _ - _ _ _ _ → GO TO OTHEXT

↓

OTHFOR. Other Phone - Foreign Number

(What is the area code and phone number?)

- ASK; or CONFIRM if phone number has been prelisted and this is the same Respondent same [Respondent / Head] as [P2YEAR]
- Ctrl-D and Ctrl-R not allowed; For DK/RF, GO BACK and ENTER [5] at WtrOther

String 20

OTHEXT. Other Phone - Extension

Is there an extension?

- If none, PRESS [Enter] to continue
- Ctrl-D and Ctrl-R not allowed; For DK/RF, PRESS [Enter] to continue

String 20

END RPHONE

HSPCKPT. CAI Checkpoint: Respondent; Whether Spouse/Partner in FU

| | | |
|-----------------------|---------------------------------------|--------------------------|
| R=Head (RESPONDENT=1) | 3. R=Spouse/Partner (RESPONDENT=2, 3) | 4. R=OFUM (RESPONDENT=4) |
| 1. Spouse/Partner | 2. No Spouse/Partner | |
| ↓ | | ↓ |
| GO TO RPAY2GCKPT | | |

ADDRPAYMENT.HSPPHONE (Prefilled with NewPreload preload)

ADDRTYPE. Which Phone

9. Head/SP

AQSN. AQSN of Current Head (R=SP, OFUM) or Current Spouse/Partner (R=HEAD)

WTRCELL. [CYNAMF CYNAMFL]: [CYAQRTH], [CYFUHU], Age [AGEIWDATE]

Does [R=SP, OFUM: [HEAD] / R=HEAD: [SP]] have a cell phone?

- Ctrl-D and Ctrl-R not allowed; For DK/RF ENTER [5]

1. Yes | 5. No → GO TO RPAY2GCKPT

↓

CELLPH. [CYNAMF CYNAMFL]: [CYAQRTH], [CYFUHU], Age [AGEIWDATE]

Cell Phone - Area Code and Telephone Number

What is the area code and phone number?

- ASK; or CONFIRM if phone number has been prelisted and this is the same [R=SP, OFUM: Head / R=HEAD: Spouse/Partner] as [P2YEAR]
- If foreign phone, PRESS [ENTER] to go to foreign phone field
- Ctrl-D and Ctrl-R not allowed; For DK/RF, GO BACK and ENTER [5] at WtrCell

[ENTER] (____)____-____ → GO TO CARRIER



CELLFOR. [CYNAMF CYNAMFL]: [CYAQRTH], [CYFUHU], Age [AGEIWDATE]

Cell Phone - Foreign Number

(What is the area code and phone number?)

- ASK; or CONFIRM if phone number has been prelisted and this is the same [Head / Spouse/Partner] as [P2YEAR]
- Ctrl-D and Ctrl-R not allowed; For DK/RF, GO BACK and ENTER [5] at WtrCell

String 20

CARRIER. [CYNAMF CYNAMFL]: [CYAQRTH], [CYFUHU], Age [AGEIWDATE]

Cell Phone - Carrier

Which carrier does that cell phone use?

| | | | | | | |
|-------------------|--|-----------------|--------------|--------------|-------------------|-------------|
| 1. Alltel | 2. AT&T | 3. Boost Mobile | 4. Cricket | 5. MetroPCS | 6. Nextel | 7. Ptel |
| 8. Qwest | 9. Sprint | 10. Suncom | 11. T-Mobile | 12. Tracfone | 13. U.S. Cellular | 14. Verizon |
| 15. Virgin Mobile | 97. Other - Specify (CARRIERSPEC. Specify cell phone carrier. (String 20)) | | | | | |

END HSPPHONE

RPAY2GCKPT. CAI Checkpoint: Respondent

1. R=Head, Spouse/Partner, OFUM (RESPONDENT=1-4) 2. R=Proxy (RESPONDENT=7) → GO TO RPAY3A



ADDRPAYMENT.RPAY2G_H[1-2] [1]=Respondent, [2]=Respondent's spouse or partner (R=HEAD, SP)

EMAILAQSN. AQSN of Respondent (Respondent's spouse or partner)

RPAY2G. [CYNAMF CYNAMFL]: [CYAQRTH], [CYFUHU], Age [AGEIWDATE]

[LOOP 2: R's Email Address: LOOP 1=YES: [RPAY2H] / LOOP 1<>YES: No email reported]

Is there an email address where we can contact [LOOP 1: you / LOOP 2: [HEAD / SP]]?

1. Yes [LOOP 2: , and is different than R's] [LOOP 2: 2. Yes, and is same as R's] 5. No → GO TO RPAY2G END RULE



Assign RPAY2H[2]=RPAY2H[1];
Then GO TO RPAY3A

(Prefilled with RespondentAddr or NewPreload email)

RPAY2H. [CYNAMF CYNAMFL]: [CYAQRTH], [CYFUHU], Age [AGEIWDATE]

(What is that e-mail address?)

- ASK; or CONFIRM if email address has been prelisted and this is the same [LOOP 1: Respondent / LOOP 2: [Head / Spouse/Partner]] as [P2YEAR]
- ENTER email address, then READ BACK and VERIFY with Respondent
- Ctrl-D and Ctrl-R not allowed; For DK/RF go back and ENTER [Ctrl-D, Ctrl-R] at previous question

String 50

RPAY2G END Rule: Respondent; Whether Spouse/Partner in FU

| | |
|--|----------------------|
| R=Head, Spouse/Partner (RESPONDENT=1-3) | R=OFUM RESPONDENT=4) |
| Spouse/Partner (CYFUHU=1, 4 & CYAQRTH=201-222) | No Spouse/Partner |
| Repeat RPAY2G-RPAY2H; Then GO TO RPAY3A | ↓ |

END RPAY2G_H

RPAY3A. Is [your / [HEAD]'s] street address where [you / he / she] actually live[s] different from the mailing address?

- STREET ADDRESS is the address where R/Head ACTUALLY LIVES, which is sometimes different from R/Head's mailing address
- Ctrl-D and Ctrl-R not allowed; For DK/RF ENTER [5]

1. Yes 5. No → GO TO RPAY4PPCKPT



ADDRPAYMENT.RPAY3B

| | |
|---|--|
| <p>INCO. Please tell me that address.</p> <p>In Care Of</p> <ul style="list-style-type: none"> • If none, PRESS [Enter] to continue • Ctrl-D and Ctrl-R not allowed; For DK/RF, PRESS [Enter] to continue <p>String 40</p> <p>ADDR1. Address 1</p> <ul style="list-style-type: none"> • DO NOT enter PO Box here, since we are asking for a <u>street address</u>. GO BACK to R's/Head's mailing address to enter PO Box • Ctrl-D and Ctrl-R not allowed; For DK/RF type [DK] or [RF] <p>String 40</p> <p>APTSTE. Apt/Suite</p> <ul style="list-style-type: none"> • If none, PRESS [Enter] to continue • Ctrl-D and Ctrl-R not allowed; For DK/RF, PRESS [Enter] to continue <p>String 10</p> <p>ADDR2. Address 2</p> <ul style="list-style-type: none"> • DO NOT enter PO Box here, since we are asking for a <u>street address</u>. GO BACK to R's/Head's mailing address to enter PO Box • If none, PRESS [Enter] to continue • Ctrl-D and Ctrl-R not allowed; For DK/RF, PRESS [Enter] to continue <p>String 40</p> | <p>CITY. City</p> <ul style="list-style-type: none"> • Ctrl-D and Ctrl-R not allowed; For DK/RF type [DK] or [RF] <p>String 40</p> <p>STATE. State</p> <ul style="list-style-type: none"> • Start typing the name of the State to bring up the look-up list • If foreign country, ENTER [FOR] to select "Foreign Country" <p>String 30; String 4</p> <p>ZIP. Zip Code</p> <ul style="list-style-type: none"> • If foreign country, ENTER all [0]'s • Ctrl-D and Ctrl-R not allowed; For DK/RF ENTER all [0]'s <p>-----</p> <p>COUNTRY. Country if different from USA</p> <ul style="list-style-type: none"> • Start typing the name of the Foreign Country to bring up the look-up list <p>String 30; String 2</p> |
|---|--|

END RPAY3B

RPAY4PPCKPT. CAI Checkpoint: Whether Interview Incentive Was Prepaid

| | | |
|---------------------------|-------------------------------|----------------|
| 1. Prepaid (WTRPREPAID=1) | 5. Not Prepaid (WTRPREPAID=0) | → GO TO RPAY4A |
| ↓ | | |

RPAY4PP. Interviewer Checkpoint

- This interview was prepaid \$[AMTPREPAID] – was the prepayment received? ASK R if needed.
 - The standard payment amount for this interview is \$^PAYMENT
 - Non-standard payment amounts can be \$^PAYMENT to \$^xRPay9a_Code
 - Other payment amounts (e.g., in addition to prepaid amount) can be \$1.00 to \$^xRPay9a_Code
- Ctrl-D and Ctrl-R not allowed; For DK/RF, ENTER [1]

| | | | |
|--|--------------------------------|---|------------------------------------|
| 1. Yes, prepayment received and accepted | → RPAY4A=1; GO TO RPAY5CKPT | 2. Yes, prepayment received but a different payment is needed | 5. No, prepayment was not received |
|--|--------------------------------|---|------------------------------------|



RPAY4A. [WTRPREPAID=1: IWER: This interview was PREPAID \$[AMTPREPAID] but R reported the prepayment was not received or a different/additional payment is needed.]

[R=HEAD, SP, OFUM: You / R=PROXY: As a proxy respondent, you] may accept the [WTRPREPAID=5: \$[PAYMENT] / WTRPREPAID=1: payment] [R=HEAD, SP, OFUM: or have it sent / R=PROXY: have it sent to [HEAD], or sent] to someone else of your choosing. Which would you prefer?

- Ctrl-D and Ctrl-R not allowed; For DK/RF ENTER [1]

| | | | |
|-------------------------------------|--|----------------------------------|------------------------------|
| 1. Respondent/Proxy accepts payment | [R=PROXY: 2. Proxy wishes that Head receive payment] | 3. Other person receives payment | 4. Payment declined (If VOL) |
|-------------------------------------|--|----------------------------------|------------------------------|

GO TO RPAY5A



GO TO RPAY5A

ADDRPAYMENT.RPAY4B

ADDRTYPE. Which Address

3. Other Payee

TITLE. Who would you like to receive the check? To what address should we send the check?

Title -- e.g. "Mr", "Mrs", "Ms", "Miss", "Dr"

- If no title, PRESS [Enter] to continue
- Ctrl-D and Ctrl-R not allowed; For DK/RF, PRESS [Enter] to continue

String 6

NAMF. First Name

- Ctrl-D and Ctrl-R not allowed; For DK/RF type [DK] or [RF]

String 20

NAMM. Middle Name

- Ask for Middle Name but do not probe DK or RF
- If none, PRESS [Enter] to continue
- Ctrl-D and Ctrl-R not allowed; For DK/RF, PRESS [Enter] to continue

String 20

NAML. Last Name

- Ctrl-D and Ctrl-R not allowed; For DK/RF type [DK] or [RF]

String 20

SUFFIX. Suffix -- e.g. "Sr", "Jr"

- If none, PRESS [Enter] to continue
- Ctrl-D and Ctrl-R not allowed; For DK/RF, PRESS [Enter] to continue

String 20

INCO. In Care Of

ADDR1. Address 1

- If R says the mailing address contains both a street address and PO Box: ENTER street address here (Address 1) and ENTER PO Box in Address 2
- Ctrl-D and Ctrl-R not allowed; For DK/RF type [DK] or [RF]

String 40

APTSTE. Apt/Suite

- If none, PRESS [Enter] to continue
- Ctrl-D and Ctrl-R not allowed; For DK/RF, PRESS [Enter] to continue

String 10

ADDR2. Address 2

- If R says the mailing address contains both a street address and PO Box: ENTER PO Box here (Address 2)
- If none, PRESS [Enter] to continue
- Ctrl-D and Ctrl-R not allowed; For DK/RF, PRESS [Enter] to continue

String 40

CITY. City

- Ctrl-D and Ctrl-R not allowed; For DK/RF type [DK] or [RF]

String 40

STATE. State

- Start typing the name of the State to bring up the look-up list
- If foreign country, ENTER [FOR] to select "Foreign Country"

String 30; String 4

ZIP. Zip Code

- If foreign country, ENTER all [0]'s
- Ctrl-D and Ctrl-R not allowed; For DK/RF ENTER all [0]'s

- If none, PRESS [Enter] to continue
- Ctrl-D and Ctrl-R not allowed; For DK/RF, PRESS [Enter] to continue

String 40

_____ - _____
COUNTRY. Country if different from USA

- Start typing the name of the Foreign Country to bring up the look-up list

String 30; String 2

END RPAY4B**ADDRPAYMENT.OPPHONE**

ADDRTYPE. Which Phone

3. Other Payee

WTRCELL. Does [OTHER PAYEE] have a cell phone?

- Ctrl-D and Ctrl-R not allowed; For DK/RF ENTER [5]

1. Yes 5. No → GO TO WTRHOME

↓

CELLPH. Cell Phone - Area Code and Telephone Number

What is the area code and phone number?

- If foreign phone, PRESS [ENTER] to go to foreign phone field
- Ctrl-D and Ctrl-R not allowed; For DK/RF, GO BACK and ENTER [5] at WtrCell

[ENTER] (____)____-_____ → GO TO CARRIER

↓

CELLFOR. Cell Phone - Foreign Number

(What is the area code and phone number?)

- Ctrl-D and Ctrl-R not allowed; For DK/RF, GO BACK and ENTER [5] at WtrCell

String 20

CARRIER. Cell Phone - Carrier

Which carrier does (his/her) cell phone use?

| | | | | | | |
|-------------------|--|-----------------|--------------|--------------|-------------------|-------------|
| 1. Alltel | 2. AT&T | 3. Boost Mobile | 4. Cricket | 5. MetroPCS | 6. Nextel | 7. Ptel |
| 8. Qwest | 9. Sprint | 10. Suncom | 11. T-Mobile | 12. Tracfone | 13. U.S. Cellular | 14. Verizon |
| 15. Virgin Mobile | 97. Other - Specify (CARRIERSPEC. Specify cell phone carrier. (String 20)) | | | | | |

WTRHOME. Does [OTHER PAYEE] have a home phone?

- Ctrl-D and Ctrl-R not allowed; For DK/RF ENTER [5]

1. Yes 5. No → GO TO WTROTHER

↓

HOMEPH. Home Phone - Area Code and Telephone Number

What is the area code and phone number?

- If foreign phone, PRESS [ENTER] to go to foreign phone field
- Ctrl-D and Ctrl-R not allowed; For DK/RF, GO BACK and ENTER [5] at WtrHome

[ENTER] (____)____-_____ → GO TO WTROTHER

↓

HOMEFOR. Home Phone - Foreign Number

(What is the area code and phone number?)

- Ctrl-D and Ctrl-R not allowed; For DK/RF, GO BACK and ENTER [5] at WtrHome

String 20

WTROTHER. Is there any other phone where we can reach [OTHER PAYEE]?

- Ctrl-D and Ctrl-R not allowed; For DK/RF ENTER [5]

1. Yes 5. No → GO TO RPAY5A



OTHPH. Other Phone - Area Code and Telephone Number

What is the area code and phone number?

- If foreign phone, PRESS [ENTER] to go to foreign phone field
- Ctrl-D and Ctrl-R not allowed; For DK/RF, GO BACK and ENTER [5] at WtrOther

[ENTER] (_ _) _ _ - _ _ _ → GO TO OTHEXT



OTHFOR. Other Phone - Foreign Number

(What is the area code and phone number?)

- Ctrl-D and Ctrl-R not allowed; For DK/RF, GO BACK and ENTER [5] at WtrOther

String 20

OTHEXT. Other Phone - Extension

Is there an extension?

- If none, PRESS [Enter] to continue
- Ctrl-D and Ctrl-R not allowed; For DK/RF, PRESS [Enter] to continue

String 20

END OPPHONE

RPAY5A. [R=HEAD, SP, OFUM: Just in case you should move [REINT, RECON: and we don't receive your address update postcard,] we would like the name of someone, such as a close friend or relative not living with you, who will know where we can reach you. / R=PROXY: Just in case [HEAD] should move [REINT, RECON: and we do not receive [his / her] address update postcard,] we would like the name of someone who could help us locate [him / her].]

- ENTER [1] to continue

1. Continue

RPAY5B. Interviewer Checkpoint

- Is there Contact Person 1 information displayed below?

1. Yes, Contact Person is displayed 5. No, no contact person is displayed → GO TO RPAY5D.TITLE



RPAY5C. Last time, we had [PRELOADED CONTACT PERSON 1] listed as a contact for [you / [HEAD]]. Would you like to continue with this contact?

- ENTER [7] if R refuses Contact Person information

| | | | | |
|--|---|---|---|---|
| [R=HEAD, SP, OFUM: 1. Yes, continue with this contact] | [R=PROXY: 2. Yes, & CP is <u>not</u> Proxy] | [R=PROXY: 3. Yes, & CP <u>is</u> Proxy] | 5. No, change CP info GO TO RPAY5D.TITLE | 7. R <u>refused</u> CP info GO TO RPAY6A |
|--|---|---|---|---|



GO TO RPAY6A

RPAY5D1. Is the address I have for [PRELOADED CONTACT PERSON 1] correct?

- READ Contact Person 1 address to R

1. Yes, address is correct → Assign ADDRTYPE=4;
Then GO TO C1PHONE

5. No, address needs updating



ADDRPAYMENT.RPAY5D (Prefilled with ContactPerson1 preload)

ADDRTYPE. Which Address

4. Contact Person 1

TITLE. Title -- e.g. "Mr", "Mrs", "Ms", "Miss", "Dr"

[RPAY5C=CONTINUE: Does (he/she) still live at this address?
/ RPAY5C=CHANGE: Who shall I list as a contact person for
[you / [HEAD]]? What is (his/her) complete name and
mailing address?]

- If needed, REMIND R: This should be someone, such as a close friend or relative not living with [you / [HEAD]], who will know where we can reach [you / (him / her)]
- If no title, PRESS [Enter] to continue
- Ctrl-D and Ctrl-R not allowed; For DK/RF, PRESS [Enter] to continue
- If R refuses Contact Person info, DO NOT ENTER anything here. GO BACK and ENTER [7] at RPay5c to exit these questions (you may need to go back and ENTER RPay5b=1 first)

String 6

NAMF. First Name

- Ctrl-D and Ctrl-R not allowed; For DK/RF type [DK] or [RF]

String 20

NAMM. Middle Name

- Ask for Middle Name but do not probe DK or RF
- If none, PRESS [Enter] to continue
- Ctrl-D and Ctrl-R not allowed; For DK/RF, PRESS [Enter] to continue

String 20

NAML. Last Name

- Ctrl-D and Ctrl-R not allowed; For DK/RF type [DK] or [RF]

String 20

SUFFIX. Suffix -- e.g. "Sr", "Jr"

- If none, PRESS [Enter] to continue
- Ctrl-D and Ctrl-R not allowed; For DK/RF, PRESS [Enter] to continue

String 20

INCO. In Care Of

- If none, PRESS [Enter] to continue
- Ctrl-D and Ctrl-R not allowed; For DK/RF, PRESS [Enter] to continue

String 40

ADDR1. Address 1

- If R says the mailing address contains both a street address and PO Box: ENTER street address here (Address 1) and ENTER PO Box in Address 2
- Ctrl-D and Ctrl-R not allowed; For DK/RF type [DK] or [RF]

String 40

APTSTE. Apt/Suite

- If none, PRESS [Enter] to continue
- Ctrl-D and Ctrl-R not allowed; For DK/RF, PRESS [Enter] to continue

String 10

ADDR2. Address 2

- If R says the mailing address contains both a street address and PO Box: ENTER PO Box here (Address 2)
- If none, PRESS [Enter] to continue
- Ctrl-D and Ctrl-R not allowed; For DK/RF, PRESS [Enter] to continue

String 40

CITY. City

- Ctrl-D and Ctrl-R not allowed; For DK/RF type [DK] or [RF]

String 40

STATE. State

- Start typing the name of the State to bring up the look-up list
- If foreign country, ENTER [FOR] to select "Foreign Country"

String 30; String 4

ZIP. Zip Code

- If foreign country, ENTER all [0]'s
- Ctrl-D and Ctrl-R not allowed; For DK/RF ENTER all [0]'s

COUNTRY. Country if different from USA

- Start typing the name of the Foreign Country to bring up the look-up list

String 30; String 2

END RPAY5D

ADDRPAYMENT.C1PHONE (Prefilled with ContactPerson1 preload)

ADDRTYPE. Which Phone

4. Contact Person 1

WTRCELL. Does [RPAY5D.NAMF RPAY5D.NAML] have a cell phone?

- Ctrl-D and Ctrl-R not allowed; For DK/RF ENTER [5]

1. Yes 5. No → GO TO WTRHOME



CELLPH. Cell Phone - Area Code and Telephone Number

What is the area code and phone number?

- ASK; or CONFIRM if phone number has been prelisted and this is the same Contact Person as [P2YEAR]
- If foreign phone, PRESS [ENTER] to go to foreign phone field
- Ctrl-D and Ctrl-R not allowed; For DK/RF, GO BACK and ENTER [5] at WtrCell

[ENTER] (____)____-____ → GO TO CARRIER



CELLFOR. Cell Phone - Foreign Number

(What is the area code and phone number?)

- ASK; or CONFIRM if phone number has been prelisted and this is the same Contact Person as [P2YEAR]
- Ctrl-D and Ctrl-R not allowed; For DK/RF, GO BACK and ENTER [5] at WtrCell

String 20

CARRIER. Cell Phone - Carrier

Which carrier does (his/her) cell phone use?

| | | | | | | |
|-------------------|--|-----------------|--------------|--------------|-------------------|-------------|
| 1. Alltel | 2. AT&T | 3. Boost Mobile | 4. Cricket | 5. MetroPCS | 6. Nextel | 7. Ptel |
| 8. Qwest | 9. Sprint | 10. Suncom | 11. T-Mobile | 12. Tracfone | 13. U.S. Cellular | 14. Verizon |
| 15. Virgin Mobile | 97. Other - Specify (CARRIERSPEC. Specify cell phone carrier. (String 20)) | | | | | |

WTRHOME. Does [RPAY5D.NAMF RPAY5D.NAML] have a home phone?

- Ctrl-D and Ctrl-R not allowed; For DK/RF ENTER [5]

1. Yes 5. No → GO TO WTROTHER



HOMEPH. Home Phone - Area Code and Telephone Number

What is the area code and phone number?

- ASK; or CONFIRM if phone number has been prelisted and this is the same Contact Person as [P2YEAR]
- If foreign phone, PRESS [ENTER] to go to foreign phone field
- Ctrl-D and Ctrl-R not allowed; For DK/RF, GO BACK and ENTER [5] at WtrHome

[ENTER] (____)____-____ → GO TO WTROTHER



HOMEFOR. Home Phone - Foreign Number

(What is the area code and phone number?)

- ASK; or CONFIRM if phone number has been prelisted and this is the same Contact Person as [P2YEAR]
- Ctrl-D and Ctrl-R not allowed; For DK/RF, GO BACK and ENTER [5] at WtrHome

String 20

WTROTHER. Is there any other phone where we can reach [RPAY5D.NAMF RPAY5D.NAML]?

- Ctrl-D and Ctrl-R not allowed; For DK/RF ENTER [5]

1. Yes 5. No → GO TO RPAY5JJ



OTHPH. Other Phone - Area Code and Telephone Number

What is the area code and phone number?

- ASK; or CONFIRM if phone number has been prelisted and this is the same Contact Person as [P2YEAR]
- If foreign phone, PRESS [ENTER] to go to foreign phone field
- Ctrl-D and Ctrl-R not allowed; For DK/RF, GO BACK and ENTER [5] at WtrOther

[ENTER] (_ _) _ _ - _ _ _ _ → GO TO OTHEXT



OTHFOR. Other Phone - Foreign Number

(What is the area code and phone number?)

- ASK; or CONFIRM if phone number has been prelisted and this is the same Contact Person as [P2YEAR]
- Ctrl-D and Ctrl-R not allowed; For DK/RF, GO BACK and ENTER [5] at WtrOther

String 20

OTHEXT. Other Phone - Extension

Is there an extension?

- If none, PRESS [Enter] to continue
- Ctrl-D and Ctrl-R not allowed; For DK/RF, PRESS [Enter] to continue

String 20

END C1PHONE

RPAY5JJ. What is (his / her) relationship to [you / [HEAD]]?

| | | | | | |
|-------------------|------------|---|-----------------|------------|-------------------|
| 1. Mother | 2. Father | 3. Son | 4. Daughter | 5. Sister | 6. Brother |
| 7. Aunt | 8. Uncle | 9. Grandmother | 10. Grandfather | 11. Friend | 12. Father-in-law |
| 13. Mother-in-law | 14. Cousin | 97. Other-Specify (RPAY5JJSPEC. Specify. (String 50)) | | | |

RPAY5K. Is there an email address where we can contact [RPAY5D.NAMF RPAY5D.NAML]?

1. Yes 5. No → GO TO RPAY6A



(Prefilled with ContactPerson1 preload)

RPAY5L. (What is that e-mail address?)

- ASK; or CONFIRM if email address has been prelisted and this is the same Contact Person as [P2YEAR]
- ENTER email address, then READ BACK and VERIFY with Respondent
- Ctrl-D and Ctrl-R not allowed; For DK/RF go back and ENTER [Ctrl-D, Ctrl-R] at previous question

String 50

RPAY6A. Interviewer Checkpoint

- Is there Contact Person 2 information displayed below?

1. Yes, Contact Person is displayed 5. No, no contact person is displayed → GO TO RPAY6C



RPAY6B. Last time, we had [PRELOADED CONTACT PERSON 2] listed as a contact for [you / [HEAD]]. Would you like to continue with this contact?

- ENTER [7] if R refuses Contact Person information

| | | | | |
|--|---|---|---|---|
| [R=HEAD, SP, OFUM: 1. Yes, continue with this contact] | [R=PROXY: 2. Yes, & CP is <u>not</u> Proxy] | [R=PROXY: 3. Yes, & CP <u>is</u> Proxy] | 5. No, change CP info GO TO RPAY6D.TITLE | 7. R <u>refused</u> CP info GO TO TY1 RULE |
| GO TO RPAY6D1 | | GO TO TY1 RULE | | |

RPAY6C. We would like to have the name of a second contact person, someone who will know where we can reach [you / [HEAD]] if the first contact is not able to help us. Is there a second contact person who can help us reach [you / [HEAD]]?

- If needed, REMIND R: This should be someone, such as a close friend or relative not living with [you / [HEAD]], who will know where we can reach [you / (him / her)]

1. Yes → GO TO RPAY6D.TITLE 5. No → GO TO TY1 RULE

RPAY6D1. Is the address I have for [PRELOADED CONTACT PERSON 2] correct?

- READ Contact Person 2 address to R

1. Yes, address is correct → Assign ADDRTYPE=5;
Then GO TO C2PHONE

5. No, address needs updating



ADDRPAYMENT.RPAY6D (Prefilled with ContactPerson2 preload)

ADDRTYPE. Which Address

5. Contact Person 2

TITLE. Title -- e.g. "Mr", "Mrs", "Ms", "Miss", "Dr"

[RPAY6B=CONTINUE: Does (he/she) still live at this address? / RPAY6B=CHANGE: Who shall I list as a contact person for [you / [HEAD]]? What is (his/her) complete name and mailing address?]

- If needed, REMIND R: This should be someone, such as a close friend or relative not living with [you / [HEAD]], who will know where we can reach [you / (him / her)]
- If no title, PRESS [Enter] to continue
- Ctrl-D and Ctrl-R not allowed; For DK/RF, PRESS [Enter] to continue
- If R refuses Contact Person info, DO NOT ENTER anything here. GO BACK and ENTER [7] at RPay6b to exit these questions (you may need to go back and ENTER RPay6a=1 first)

String 6

NAMF. First Name

- Ctrl-D and Ctrl-R not allowed; For DK/RF type [DK] or [RF]

String 20

NAMM. Middle Name

- Ask for Middle Name but do not probe DK or RF
- If none, PRESS [Enter] to continue
- Ctrl-D and Ctrl-R not allowed; For DK/RF, PRESS [Enter] to continue

String 20

NAML. Last Name

ADDR1. Address 1

- If R says the mailing address contains both a street address and PO Box: ENTER street address here (Address 1) and ENTER PO Box in Address 2
- Ctrl-D and Ctrl-R not allowed; For DK/RF type [DK] or [RF]

String 40

APTSTE. Apt/Suite

- If none, PRESS [Enter] to continue
- Ctrl-D and Ctrl-R not allowed; For DK/RF, PRESS [Enter] to continue

String 10

ADDR2. Address 2

- If R says the mailing address contains both a street address and PO Box: ENTER PO Box here (Address 2)
- If none, PRESS [Enter] to continue
- Ctrl-D and Ctrl-R not allowed; For DK/RF, PRESS [Enter] to continue

String 40

CITY. City

- Ctrl-D and Ctrl-R not allowed; For DK/RF type [DK] or [RF]

String 40

STATE. State

- Start typing the name of the State to bring up the look-up list
- If foreign country, ENTER [FOR] to select "Foreign Country"

String 30; String 4

ZIP. Zip Code

| | |
|--|---|
| <ul style="list-style-type: none"> Ctrl-D and Ctrl-R not allowed; For DK/RF type [DK] or [RF] <input type="text" value="String 20"/> <p>SUFFIX. Suffix -- e.g. "Sr", "Jr"</p> <ul style="list-style-type: none"> If none, PRESS [Enter] to continue Ctrl-D and Ctrl-R not allowed; For DK/RF, PRESS [Enter] to continue <input type="text" value="String 20"/> <p>INCO. In Care Of</p> <ul style="list-style-type: none"> If none, PRESS [Enter] to continue Ctrl-D and Ctrl-R not allowed; For DK/RF, PRESS [Enter] to continue <input type="text" value="String 40"/> | <ul style="list-style-type: none"> If foreign country, ENTER all [0]'s Ctrl-D and Ctrl-R not allowed; For DK/RF ENTER all [0]'s <input type="text" value="-----"/> <p>COUNTRY. Country if different from USA</p> <ul style="list-style-type: none"> Start typing the name of the Foreign Country to bring up the look-up list <input type="text" value="String 30; String 2"/> |
|--|---|

END RPAY6D**ADDRPAYMENT.C2PHONE** (Prefilled with ContactPerson2 preload)

ADDRTYPE. Which Phone

WTRCELL. Does [RPAY6D.NAMF RPAY6D.NAML] have a cell phone?

- Ctrl-D and Ctrl-R not allowed; For DK/RF ENTER [5]

 → GO TO WTRHOME

CELLPH. Cell Phone - Area Code and Telephone Number

What is the area code and phone number?

- ASK; or CONFIRM if phone number has been prelisted and this is the same Contact Person as [P2YEAR]
- If foreign phone, PRESS [ENTER] to go to foreign phone field
- Ctrl-D and Ctrl-R not allowed; For DK/RF, GO BACK and ENTER [5] at WtrCell

 → GO TO CARRIER

CELLFOR. Cell Phone - Foreign Number

(What is the area code and phone number?)

- ASK; or CONFIRM if phone number has been prelisted and this is the same Contact Person as [P2YEAR]
- Ctrl-D and Ctrl-R not allowed; For DK/RF, GO BACK and ENTER [5] at WtrCell

CARRIER. Cell Phone - Carrier

Which carrier does (his/her) cell phone use?

| | | | | | | |
|--|---|--|---|---|--|--|
| <input type="text" value="1. Alltel"/> | <input type="text" value="2. AT&T"/> | <input type="text" value="3. Boost Mobile"/> | <input type="text" value="4. Cricket"/> | <input type="text" value="5. MetroPCS"/> | <input type="text" value="6. Nextel"/> | <input type="text" value="7. Ptel"/> |
| <input type="text" value="8. Qwest"/> | <input type="text" value="9. Sprint"/> | <input type="text" value="10. Suncom"/> | <input type="text" value="11. T-Mobile"/> | <input type="text" value="12. Tracfone"/> | <input type="text" value="13. U.S. Cellular"/> | <input type="text" value="14. Verizon"/> |
| <input type="text" value="15. Virgin Mobile"/> | <input type="text" value="97. Other - Specify (CARRIERSPEC. Specify cell phone carrier. (String 20))"/> | | | | | |

WTRHOME. Does [RPAY6D.NAMF RPAY6D.NAML] have a home phone?

- Ctrl-D and Ctrl-R not allowed; For DK/RF ENTER [5]

1. Yes 5. No → GO TO WTROTHER



HOMEPH. Home Phone - Area Code and Telephone Number

What is the area code and phone number?

- ASK; or CONFIRM if phone number has been prelisted and this is the same Contact Person as [P2YEAR]
- If foreign phone, PRESS [ENTER] to go to foreign phone field
- Ctrl-D and Ctrl-R not allowed; For DK/RF, GO BACK and ENTER [5] at WtrHome

[ENTER] (_ _) _ _ - _ _ _ → GO TO WTROTHER



HOMEFOR. Home Phone - Foreign Number

(What is the area code and phone number?)

- ASK; or CONFIRM if phone number has been prelisted and this is the same Contact Person as [P2YEAR]
- Ctrl-D and Ctrl-R not allowed; For DK/RF, GO BACK and ENTER [5] at WtrHome

String 20

WTROTHER. Is there any other phone where we can reach [RPAY6D.NAMF RPAY6D.NAML]?

- Ctrl-D and Ctrl-R not allowed; For DK/RF ENTER [5]

1. Yes 5. No → GO TO RPAY6JJ



OTHPH. Other Phone - Area Code and Telephone Number

What is the area code and phone number?

- ASK; or CONFIRM if phone number has been prelisted and this is the same Contact Person as [P2YEAR]
- If foreign phone, PRESS [ENTER] to go to foreign phone field
- Ctrl-D and Ctrl-R not allowed; For DK/RF, GO BACK and ENTER [5] at WtrOther

[ENTER] (_ _) _ _ - _ _ _ → GO TO OTHEXT



OTHFOR. Other Phone - Foreign Number

(What is the area code and phone number?)

- ASK; or CONFIRM if phone number has been prelisted and this is the same Contact Person as [P2YEAR]
- Ctrl-D and Ctrl-R not allowed; For DK/RF, GO BACK and ENTER [5] at WtrOther

String 20

OTHEXT. Other Phone - Extension

Is there an extension?

- If none, PRESS [Enter] to continue
- Ctrl-D and Ctrl-R not allowed; For DK/RF, PRESS [Enter] to continue

String 20

END C2PHONE

RPAY6JJ. What is (his / her) relationship to [you / [HEAD]]?

| | | | | | |
|-------------------|------------|---|-----------------|------------|-------------------|
| 1. Mother | 2. Father | 3. Son | 4. Daughter | 5. Sister | 6. Brother |
| 7. Aunt | 8. Uncle | 9. Grandmother | 10. Grandfather | 11. Friend | 12. Father-in-law |
| 13. Mother-in-law | 14. Cousin | 97. Other-Specify (RPAY6JJSPEC. Specify. (String 50)) | | | |

RPAY6K. Is there an email address where we can contact [RPAY6D.NAMF RPAY6D.NAML]?

1. Yes 5. No → GO TO TY1 RULE

↓

(Prefilled with ContactPerson2 preload)

RPAY6L. (What is that e-mail address?)

- ASK; or CONFIRM if email address has been prelisted and this is the same Contact Person as [P2YEAR]
- ENTER email address, then READ BACK and VERIFY with Respondent
- Ctrl-D and Ctrl-R not allowed; For DK/RF go back and ENTER [Ctrl-D, Ctrl-R] at previous question

String 50

TY1 Rule: Whether TAS Eligible Individuals Age 17 or Older in FU

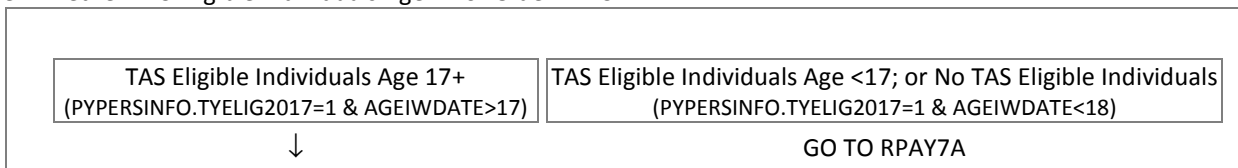

ADDRPAYMENT.TY[1-24] [1-24]=AQSN of FU Member

TYAQSN. AQSN of TAS FU Member

TY1. **TAS Eligible Person:** [CYNAMF CYNAML] [CYAQRTH]

[R=TAS FU MEMBER: You / ALL OTHERS: [CYNAMF CYNAML]] [AGE=17: may [LOOP 2+: also] be / AGE>17: [are / is] [LOOP 2+: also]] eligible to participate in a new survey we will be doing in the near future. Will we be able to reach [you / [CYNAMF CYNAML]] at [CYFUHU=FU, FUMI: your current address and phone number / CYFUHU=MO, MIL, EDUC: the address and phone number that you gave me earlier]?

1. Yes → GO TO TY EMAIL RULE 5. No DK/RF

↓

TY2. **TAS Eligible Person:** [CYNAMF CYNAML] [CYAQRTH]

Do you know what [your / his / her] new address and phone number will be?

1. Yes 5. No → GO TO TY EMAIL RULE

↓

ADDR1. **TAS Eligible Person:** [CYNAMF CYNAML] [CYAQRTH]

- Address 1
- Enter P.O. Box in Addr2
- Record complete street address including apartment/suite number here
- Record any college or university or military base name here
- Ctrl-D and Ctrl-R not allowed; For DK/RF type [DK] or [RF]

String 40

ADDR2. **TAS Eligible Person:** [CYNAMF] [CYNAML] [CYAQRTH]

- Address 2
- Enter P.O. Box here
- If none, PRESS [Enter] to continue
- Ctrl-D and Ctrl-R not allowed; For DK/RF, PRESS [Enter] to continue

String 40

CITY. TAS Eligible Person: [CYNAMF CYNAML] [CYAQRTH]

City

- Ctrl-D and Ctrl-R not allowed; For DK/RF type [DK] or [RF]

String 40

STATE. TAS Eligible Person: [CYNAMF CYNAML] [CYAQRTH]

State

- Start typing the name of the State to bring up the look-up list
- If foreign country, ENTER [FOR] to select "Foreign Country"

String 30; String 4

ZIP. TAS Eligible Person: [CYNAMF CYNAML] [CYAQRTH]

Zip Code

- If foreign country, ENTER all [0]'s
- Ctrl-D and Ctrl-R not allowed; For DK/RF ENTER all [0]'s

COUNTRY. TAS Eligible Person: [CYNAMF CYNAML] [CYAQRTH]

Country if different from USA

- Start typing the name of the Foreign Country to bring up the look-up list

String 30; String 2

PHONE. TAS Eligible Person: [CYNAMF CYNAML] [CYAQRTH]

What is the area code and phone number?

Area Code and Telephone Number

- If foreign phone, ENTER all [0]'s and put foreign number in next field
- Ctrl-D and Ctrl-R not allowed; For DK/RF ENTER all [0]'s

(____) ____ - ____

EXTENSION. TAS Eligible Person: [CYNAMF CYNAML] [CYAQRTH]

Extension?

- Enter foreign phone number in this field
- If none, PRESS [Enter] to continue
- Ctrl-D and Ctrl-R not allowed; For DK/RF, PRESS [Enter] to continue

String 20

TY3. TAS Eligible Person: [CYNAMF CYNAML] [CYAQRTH]

Is this a home phone, work phone, cell phone, or what?

- For educational or military group housing, use [7 - Other specify] and PROBE: "Is that phone number for a private telephone or one that is used by several people?"
- Ctrl-D and Ctrl-R not allowed; For DK/RF ENTER [8]

1. Home phone or residence 2. Work phone 3. Cell phone 4. Pager 5. Fax 6. VoIP

7. Other-specify (TY3SPEC. Specify (String 50)) 8. Don't know

TY EMAIL Rule: Respondent

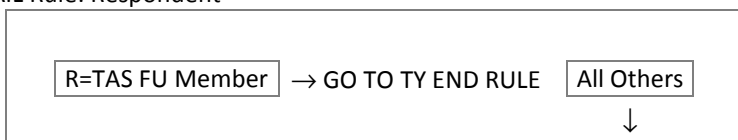

TYEMAIL. **TAS Eligible Person:** [CYNAMF CYNAML] [CYAQRTH]

Is there an email address where we can contact [CYNAMF]?

1. Yes 5. No → GO TO TY END RULE



TYEMAILADDR. **TAS Eligible Person:** [CYNAMF CYNAML] [CYAQRTH]

(What is that email address?)

- ENTER email address, then READ BACK and VERIFY with Respondent
- Ctrl-D and Ctrl-R not allowed; For DK/RF go back and ENTER [Ctrl-D, Ctrl-R] at previous question

TY END Rule: Whether More Eligible TAS FU Members in FU

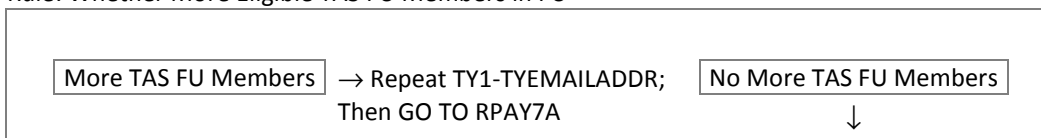

END TY

RPAY7A. **Interviewer Checkpoint**

- Are there others in this family folder whose address and phone number need updating?

1. Yes 5. No → GO TO RPAY7C



RPAY7B. We would like to update our address and phone number information for other members of [your / HEAD] family who are also participants in our study. Could you help me with that?

- If Yes, make paper notes to update address information – enter in SurveyTrak later

1. Yes 5. No

NOTE: If SurveyTrak *tsample_line.vext_059* (Was cell phone payment offered?) =Yes/No, then value "1" is pushed into RPAY7C.

RPAY7C. **Interviewer Checkpoint**

- Did Respondent use a cell phone to complete this interview?

1. Yes 5. No → GO TO RPAY9ACKPT



SIGNAL FOR RPAY7C=YES:

IWER: You entered that R completed this interview using a cell phone.

- If this is true, click Suppress to confirm.
- If R did not use a cell phone to complete this interview, click Close and change your response to No.

RPAY7D. **Interviewer Checkpoint**

- Was a cell phone payment offered by you or anyone else?

1. Yes 5. No

RPAY9ACKPT. CAI Checkpoint: Whether Payment Accepted or Declined

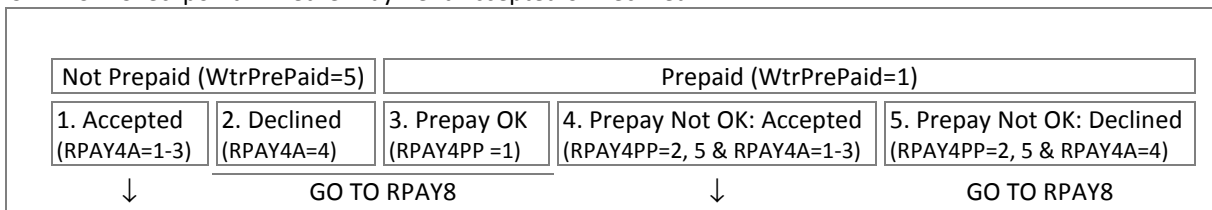

RPAY9A. Interviewer Checkpoint

WTRPREPAID=5: Tell us the type of Respondent payment to make

- The standard payment amount for this interview is \$[PAYMENT]
- Non-standard payment amounts can be \$[PAYMENT] to \$[PAYMENT*2]
- ENTER [1, 7] or [2, 7] to record a cell phone payment and/or temporary mailing address **in addition to** a standard check/money order payment
- Ctrl-D and Ctrl-R not allowed

WTRPREPAID=1: IWER: This interview was PREPAID \$[AMTPREPAID] but R reported the prepayment was not received or a different/additional payment is needed

- The standard payment amount for this interview is \$[PAYMENT]
- Non-standard payment amounts can be \$[PAYMENT] to \$[PAYMENT*2]
- Other payment amounts (e.g., in addition to prepaid amount) can be \$1.00 to \$^xRPay9a_Code
- ENTER [5] if a cash payment was made or ENTER [7] to request a check payment/special handling
- Ctrl-D and Ctrl-R not allowed

[*WTRPREPAID=5*: 1. Pay by check in standard amount of \$[PAYMENT] (*Exclusive of 2, 5*)]

[*WTRPREPAID=5*: 2. Pay by money order in standard amount of \$[PAYMENT] (*Exclusive of 1, 5*)]

→ GO TO RPAY8

5. Cash payment made (*Exclusive of 1, 2, 7*)

→ GO TO RPAY9B

7. Special handling: [*WTRPREPAID=5*: Non-standard / *WTRPREPAID=1*: Payment] amount, cell phone payment, temporary address

→ GO TO RPAY9D

SIGNAL FOR RPAY9A=MONEY ORDER:

You have selected money order as method of payment.

READ TO R: A money order would delay payment by 1-2 weeks, and if it is lost cannot be replaced for 6-8 weeks.

Is that okay or should we issue a check instead?

Change your selection to [1. Check] if necessary.

SIGNAL FOR RPAY7D=YES & RPAY9A=CHECK, MONEY ORDER & RPAY9A<>SPECIAL HANDLING:

INTERVIEW WAS COMPLETED USING CELL PHONE and CELL PHONE PAYMENT HAS BEEN OFFERED.

Standard payments by check or money order: ENTER [7] in addition to [1] or [2].

Non-standard payment amounts: ENTER [7].

Cash payments: a separate screen will automatically ask for cell phone payment amount.

RPAY9B. [*WTRPREPAID=1*: IWER: This interview was PREPAID \$[AMTPREPAID] but R reported the prepayment was not received or a different/additional payment is needed]

When did you make the [*WTRPREPAID=1*: different /additional] cash payment?

- ENTER MM/DD/[CYEAR], with or without slashes
- Ctrl-D and Ctrl-R not allowed

__ / __ / [CYEAR]

RPAY9C. [*WTRPREPAID=1*: IWER: This interview was PREPAID \$[AMTPREPAID] but R reported the prepayment was not received or a different/additional payment is needed]

How much was the cash Respondent payment for this interview?

- The standard payment amount for this interview is \$[PAYMENT]
- Non-standard payment amounts can be \$[PAYMENT] to \$[PAYMENT*2]
- [*WTRPREPAID=1*: Other payment amounts (e.g., in addition to prepaid amount) can be \$1.00 to \$[PAYMENT*2]]
- **DO NOT INCLUDE** amount for cell phone payment here – record this separately at the next screen
- Ctrl-D and Ctrl-R not allowed

WTRPREPAID=5 \$[PAYMENT] - [PAYMENT*2]

WTRPREPAID=1 \$1.00 - [PAYMENT*2]

RPAY9C2. How much, if any, was the cash Respondent payment for cell phone use?

- ENTER either \$0.00 or \$10.00
- Standard payment for cell phone use is \$10.00
- Ctrl-D and Ctrl-R not allowed

\$ 0.00; 10.00

GO TO RPAY8

SIGNAL FOR RPAY7D=YES & RPAY9C2=\$0:

INTERVIEW WAS COMPLETED USING CELL PHONE and CELL PHONE PAYMENT HAS BEEN OFFERED.

Cash payments: RECORD amount paid for cell phone use

RPAY9D. [*WTRPREPAID=1: IWER: This interview was PREPAID \$[AMTPREPAID] but R reported the prepayment was not received or a different/additional payment is needed*]

Please indicate the type(s) of [*WTRPREPAID=1: payment/*] special handling needed.

- ENTER all that apply
- Ctrl-D and Ctrl-R not allowed

[*WTRPREPAID=5 & RPAY9A<>1, 2: 1. Non-standard IW payment*]

ASK RPAY9DAMT

2. Temporary mailing address

ASK RPAY9D.TITLE

3. Cell phone use payment, \$10

GO TO CHECK BEFORE RPAY8

[*WTRPREPAID=1: 4. Additional or new payment*]

ASK RPAY9DAMT

7. Other-specify

ASK RPAY9DSPEC

SIGNAL FOR RPAY7D=YES & RPAY9D<>CELL PHONE:

INTERVIEW WAS COMPLETED USING CELL PHONE and CELL PHONE PAYMENT HAS BEEN OFFERED.

Standard and non-standard payments: ENTER [3] to select cell phone payment.

RPAY9DAMT. [*WTRPREPAID=1: IWER: This interview was PREPAID \$[AMTPREPAID] but R reported the prepayment was not received or a different/additional payment is needed*]

How much is the Respondent payment for this interview?

- The standard payment amount for this interview is \$[PAYMENT]
- Non-standard payment amounts can be \$[PAYMENT] to \$[PAYMENT*2]
- [*WTRPREPAID=1: Other payment amounts (e.g., in addition to prepaid amount) can be \$1.00 to \$[PAYMENT*2]*]
- DO NOT INCLUDE amount for cell phone payment here – a separate check must be issued for cell phone payment. Go back to RPay9d and select “3 - Cell phone payment”
- Ctrl-D and Ctrl-R not allowed

WTRPREPAID=5 \$[PAYMENT] - [PAYMENT*2]

WTRPREPAID=1 \$1.00 - [PAYMENT*2]

RPAY9DSPEC. Please specify other special handling needed

- But, go back to temporary address to record address where payment should be sent

String 500

ADDRPAYMENT.RPAY9DADDR

ADDRTYPE. Which Address

TITLE. What is that name and address?

Title -- e.g. "Mr", "Mrs", "Ms", "Miss", "Dr"

- If no title, PRESS [Enter] to continue
- Ctrl-D and Ctrl-R not allowed; For DK/RF, PRESS [Enter] to continue

NAMF. First Name

- Ctrl-D and Ctrl-R not allowed; For DK/RF type [DK] or [RF]

NAML. Last Name

- Ctrl-D and Ctrl-R not allowed; For DK/RF type [DK] or [RF]

SUFFIX. Suffix -- e.g. "Sr", "Jr"

- If none, PRESS [Enter] to continue
- Ctrl-D and Ctrl-R not allowed; For DK/RF, PRESS [Enter] to continue

INCO. In Care Of

- If none, PRESS [Enter] to continue
- Ctrl-D and Ctrl-R not allowed; For DK/RF, PRESS [Enter] to continue

ADDR1. Address 1

- IF the mailing address contains both a street address and PO Box: ENTER street address here (Address 1) and ENTER PO Box in Address 2
- Ctrl-D and Ctrl-R not allowed; For DK/RF type [DK] or [RF]

APTSTE. Apt/Suite

- If none, PRESS [Enter] to continue
- Ctrl-D and Ctrl-R not allowed; For DK/RF, PRESS [Enter] to continue

ADDR2. Address 2

- IF the mailing address contains both a street address and PO Box: ENTER PO Box here (Address 2)
- If none, PRESS [Enter] to continue
- Ctrl-D and Ctrl-R not allowed; For DK/RF, PRESS [Enter] to continue

CITY. City

- Ctrl-D and Ctrl-R not allowed; For DK/RF type [DK] or [RF]

STATE. State

- Start typing the name of the State to bring up the look-up list
- If foreign country, ENTER [FOR] to select "Foreign Country"

ZIP. Zip Code

- If foreign country, ENTER all [0]'s
- Ctrl-D and Ctrl-R not allowed; For DK/RF ENTER all [0]'s

COUNTRY. Country if different from USA

- Start typing the name of the Foreign Country to bring up the look-up list

END RPAY9DADDR

CHECK FOR NO PAYMENT SELECTED AT RPAY4A, RPAY9A, OR RPAY9D:

You must select an interview payment type at RPAY9A or RPAY9D.

WHYCKPT: CAI Checkpoint. Interview Type

→ GO TO RPAY8



WHYFES. There are many different reasons that families participate in the F.E.S (Family Economics Study). What are the reasons that [R=HEAD, SP, OFUM: your / R=PROXY: this] family participates?

- ENTER all that apply

| | | |
|--|--|---|
| 1. Enjoys the interview | 2. Feels loyal to the study | 3. Cares about the importance of the study to science |
| 4. Feels loyal to other family members who started with the study many years ago | | |
| 5. Likes payment/token of appreciation | 7. Other-specify (WHYFESSPEC. Specify. (String 100)) | |

WHYFES Rule: Number of Selections at WHYFES

| | | |
|-------------------------|---------------------------|---------------|
| More Than One Selection | Only One Selection, DK/RF | → GO TO RPAY8 |
| ↓ | | |

WHYFESMAIN. What is the main reason that [your / this] family participates?

| | | |
|--|-----------------------------|---|
| 1. Enjoys the interview | 2. Feels loyal to the study | 3. Cares about the importance of the study to science |
| 4. Feels loyal to other family members who started with the study many years ago | | |
| 5. Likes payment/token of appreciation | 7. [WHYFESSPEC] | |

RPAY8. Thank you, these are all the questions I have for you. As part of our quality control procedures, another interviewer from The University of Michigan may call you back to ask a few questions about this interview and to answer any questions you may have about the interview process.

- ENTER [1] to continue

| |
|-------------|
| 1. Continue |
|-------------|

NOTE: Locator 1 data are pushed from SurveyTrak tsample_line_address into Blaise: vExt_032 (AddrPayment.RPay10a), stitle_long (AddrPayment.RPay10b.Title), vFirstName (AddrPayment.RPay10b.NamF), vMiddleName (AddrPayment.RPay10b.NamM), vLastName (AddrPayment.RPay10b.NamL), sSuffix (AddrPayment.RPay10b.Suffix), vInCareOf (AddrPayment.RPay10b.InCo), vAddressLine1 (AddrPayment.RPay10b.Addr1), vUSPS_Secondary_Address (AddrPayment.RPay10b.AptSte), vAddressLine2 (AddrPayment.RPay10b.Addr2), sCity (AddrPayment.RPay10b.City), sState (AddrPayment.RPay10b.State), sPostalCode (AddrPayment.RPay10b.Zip), sCountry (AddrPayment.RPay10b.Country), sPhone (AddrPayment.L1Phone.CellPh), vext_017 (AddrPayment.L1Phone.CellFor), vext_018 (AddrPayment.L1Phone.Carrier), vext_019 (AddrPayment.L1Phone.CarrierSpec), sphone2 (AddrPayment.L1Phone.HomePh), vext_027 (AddrPayment.L1Phone.HomeFor), vext_028 (AddrPayment.L1Phone.OthPh), vext_029 (AddrPayment.L1Phone.OthFor), vext_008 (AddrPayment.L1Phone.OthExt), vRelationship (AddrPayment.RPay10gg), vExt_012 (AddrPayment.RPay10ggSpec), vExt_060 (AddrPayment.RPay10h), vExt_061 (AddrPayment.RPay10i)

RPAY10A. Interviewer Checkpoint

- Did you or any other interviewer offer a Locator Fee to get this interview?

| | | |
|--------|-------|----------------|
| 1. Yes | 5. No | → GO TO RPAY12 |
|--------|-------|----------------|



ADDRPAYMENT.RPAY10B

| | |
|---|--|
| <p>ADDRTYPE. Which Address</p> <p>6. Locator 1</p> <p>TITLE. Enter name and mailing address for Locator #1 Title -- e.g. "Mr", "Mrs", "Ms", "Miss", "Dr"</p> <ul style="list-style-type: none"> • If no title, PRESS [Enter] to continue • Ctrl-D and Ctrl-R not allowed; For DK/RF, PRESS [Enter] to continue <p>String 6</p> <p>NAMF. First Name</p> <ul style="list-style-type: none"> • Ctrl-D and Ctrl-R not allowed; For DK/RF type [DK] or [RF] | <p>ADDR1. Address 1</p> <ul style="list-style-type: none"> • IF the mailing address contains both a street address and PO Box: ENTER street address here (Address 1) and ENTER PO Box in Address 2 • Ctrl-D and Ctrl-R not allowed; For DK/RF type [DK] or [RF] <p>String 40</p> <p>APTSTE. Apt/Suite</p> <ul style="list-style-type: none"> • If none, PRESS [Enter] to continue • Ctrl-D and Ctrl-R not allowed; For DK/RF, PRESS [Enter] to continue <p>String 10</p> |
|---|--|

| | |
|---|--|
| <p>String 20</p> <p>NAMM. Middle Name</p> <ul style="list-style-type: none"> Ask for Middle Name but do not probe DK or RF If none, PRESS [Enter] to continue Ctrl-D and Ctrl-R not allowed; For DK/RF, PRESS [Enter] to continue <p>String 20</p> <p>NAML. Last Name</p> <ul style="list-style-type: none"> Ctrl-D and Ctrl-R not allowed; For DK/RF type [DK] or [RF] <p>String 20</p> <p>SUFFIX. Suffix -- e.g. "Sr", "Jr"</p> <ul style="list-style-type: none"> If none, PRESS [Enter] to continue Ctrl-D and Ctrl-R not allowed; For DK/RF, PRESS [Enter] to continue <p>String 20</p> <p>INCO. In Care Of</p> <ul style="list-style-type: none"> If none, PRESS [Enter] to continue Ctrl-D and Ctrl-R not allowed; For DK/RF, PRESS [Enter] to continue <p>String 40</p> | <p>ADDR2. Address 2</p> <ul style="list-style-type: none"> If the mailing address contains both a street address and PO Box: ENTER PO Box here (Address 2) If none, PRESS [Enter] to continue Ctrl-D and Ctrl-R not allowed; For DK/RF, PRESS [Enter] to continue <p>String 40</p> <p>CITY. City</p> <ul style="list-style-type: none"> Ctrl-D and Ctrl-R not allowed; For DK/RF type [DK] or [RF] <p>String 40</p> <p>STATE. State</p> <ul style="list-style-type: none"> Start typing the name of the State to bring up the look-up list If foreign country, ENTER [FOR] to select "Foreign Country" <p>String 30; String 4</p> <p>ZIP. Zip Code</p> <ul style="list-style-type: none"> If foreign country, ENTER all [0]'s Ctrl-D and Ctrl-R not allowed; For DK/RF ENTER all [0]'s <p>-----</p> <p>COUNTRY. Country if different from USA</p> <ul style="list-style-type: none"> Start typing the name of the Foreign Country to bring up the look-up list <p>String 30; String 2</p> |
|---|--|

END RPAY10B*SIGNAL FOR LOCATOR 1:*

IWER: Make sure that Helper/Locator's name and address are complete.

Payments will NOT be made to incomplete names or addresses. If any field is Missing/DK/RF, SUSPEND the interview until you have the correct information.

ADDRPAYMENT.L1PHONE

ADDRTYPE. Which Phone

6. Locator 1

WTRCELL. Does [RPAY10B.NAMF RPAY10B.NAML] have a cell phone?

- Ctrl-D and Ctrl-R not allowed; For DK/RF ENTER [5]

1. Yes 5. No → GO TO WTRHOME

↓

CELLPH. Cell Phone - Area Code and Telephone Number

What is the area code and phone number?

- If foreign phone, PRESS [ENTER] to go to foreign phone field
- Ctrl-D and Ctrl-R not allowed; For DK/RF, GO BACK and ENTER [5] at WtrCell

[ENTER] (____)____-____ → GO TO CARRIER

↓

CELLFOR. [Cell Phone - Foreign Number](#)

(What is the area code and phone number?)

- Ctrl-D and Ctrl-R not allowed; For DK/RF, GO BACK and ENTER [5] at WtrCell

String 20

CARRIER. [Cell Phone - Carrier](#)

Which carrier does your cell phone use?

| | | | | | | |
|-------------------|--|-----------------|--------------|--------------|-------------------|-------------|
| 1. Alltel | 2. AT&T | 3. Boost Mobile | 4. Cricket | 5. MetroPCS | 6. Nextel | 7. Ptel |
| 8. Qwest | 9. Sprint | 10. Suncom | 11. T-Mobile | 12. Tracfone | 13. U.S. Cellular | 14. Verizon |
| 15. Virgin Mobile | 97. Other - Specify (CARRIERSPEC. Specify cell phone carrier. (String 20)) | | | | | |

WTRHOME. Does [RPAY10B.NAMF RPAY10B.NAML] have a home phone?

- Ctrl-D and Ctrl-R not allowed; For DK/RF ENTER [5]

1. Yes 5. No → GO TO WTROTHER

↓

HOMEPH. [Home Phone - Area Code and Telephone Number](#)

What is the area code and phone number?

- If foreign phone, PRESS [ENTER] to go to foreign phone field
- Ctrl-D and Ctrl-R not allowed; For DK/RF, GO BACK and ENTER [5] at WtrHome

[ENTER] (_ _) _ _ - _ _ _ → GO TO WTROTHER

↓

HOMEFOR. [Home Phone - Foreign Number](#)

(What is the area code and phone number?)

- Ctrl-D and Ctrl-R not allowed; For DK/RF, GO BACK and ENTER [5] at WtrHome

String 20

WTROTHER. Is there any other phone where we can reach [RPAY10B.NAMF RPAY10B.NAML]?

- Ctrl-D and Ctrl-R not allowed; For DK/RF ENTER [5]

1. Yes 5. No → GO TO RPAY10GG

↓

OTHPH. [Other Phone - Area Code and Telephone Number](#)

What is the area code and phone number?

- If foreign phone, PRESS [ENTER] to go to foreign phone field
- Ctrl-D and Ctrl-R not allowed; For DK/RF, GO BACK and ENTER [5] at WtrOther

[ENTER] (_ _) _ _ - _ _ _ → GO TO OTHEXT

↓

OTHFOR. [Other Phone - Foreign Number](#)

(What is the area code and phone number?)

- Ctrl-D and Ctrl-R not allowed; For DK/RF, GO BACK and ENTER [5] at WtrOther

String 20

OTHEXT. [Other Phone - Extension](#)

Is there an extension?

- If none, PRESS [Enter] to continue
- Ctrl-D and Ctrl-R not allowed; For DK/RF, PRESS [Enter] to continue

String 20

END L1PHONE

RPAY10GG. What is (his/her) relationship to [HEAD]?

| | | | | | |
|-------------------|------------|--|-----------------|------------|-------------------|
| 1. Mother | 2. Father | 3. Son | 4. Daughter | 5. Sister | 6. Brother |
| 7. Aunt | 8. Uncle | 9. Grandmother | 10. Grandfather | 11. Friend | 12. Father-in-law |
| 13. Mother-in-law | 14. Cousin | 97. Other-Specify (RPAY10GGSPEC. Specify. (String 50)) | | | |

RPAY10H. How much did you offer Locator #1?

| | | |
|------------------------|----------------------------|--|
| 10. Ten dollars (\$10) | 15. Fifteen dollars (\$15) | 20. Twenty dollars (\$20) – with TL approval |
|------------------------|----------------------------|--|

RPAY10I. Can Locator #1 be paid by check or did (he/she) request a money order?

| | | | | |
|---------------|----------------|---------|---------------------|-------|
| 1. Check | 2. Money Order | 3. Cash | 4. Declined Payment | DK/RF |
| GO TO RPAY11A | | ↓ | GO TO RPAY11A | |

RPAY10J. When was Locator #1 paid?

- ENTER MM/DD/[CYEAR], with or without slashes

| |
|-------------------|
| __ / __ / [CYEAR] |
|-------------------|

NOTE: Locator 2 data are pushed from SurveyTrak tsample_line_address into Blaise: vExt_033 (AddrPayment.RPay11a), stitle_long (AddrPayment.RPay11b.Title), vFirstName (AddrPayment.RPay11b.NamF), vMiddleName (AddrPayment.RPay11b.NamM), vLastName (AddrPayment.RPay11b.NamL), sSuffix (AddrPayment.RPay11b.Suffix), vInCareOf (AddrPayment.RPay11b.InCo), vAddressLine1 (AddrPayment.RPay11b.Addr1), vUSPS_Secondary_Address (AddrPayment.RPay11b.AptSte), vAddressLine2 (AddrPayment.RPay11b.Addr2), sCity (AddrPayment.RPay11b.City), sState (AddrPayment.RPay11b.State), sPostalCode (AddrPayment.RPay11b.Zip), sCountry (AddrPayment.RPay11b.Country), sPhone (AddrPayment.L2Phone.CellPh), vext_017 (AddrPayment.L2Phone.CellFor), vext_018 (AddrPayment.L2Phone.Carrier), vext_019 (AddrPayment.L2Phone.CarrierSpec), sphone2 (AddrPayment.L2Phone.HomePh), vext_027 (AddrPayment.L2Phone.HomeFor), vext_028 (AddrPayment.L2Phone.OthPh), vext_029 (AddrPayment.L2Phone.OthFor), vext_008 (AddrPayment.L2Phone.OthExt), vRelationship (AddrPayment.RPay11gg), vExt_012 (AddrPayment.RPay11ggSpec), vExt_062 (AddrPayment.RPay11h), vExt_063 (AddrPayment.RPay11i)

RPAY11A. Interviewer Checkpoint

- Was there a second Locator Fee offered for this interview?

| | | |
|--------|-------|----------------|
| 1. Yes | 5. No | → GO TO RPAY12 |
|--------|-------|----------------|



ADDRPAYMENT.RPAY11B

ADDRTYPE. Which Address

| |
|--------------|
| 7. Locator 2 |
|--------------|

TITLE. Enter name and mailing address for Locator #2

Title -- e.g. "Mr", "Mrs", "Ms", "Miss", "Dr"

- If no title, PRESS [Enter] to continue
- Ctrl-D and Ctrl-R not allowed; For DK/RF, PRESS [Enter] to continue

| |
|----------|
| String 6 |
|----------|

NAMF. First Name

- Ctrl-D and Ctrl-R not allowed; For DK/RF type [DK] or [RF]

| |
|-----------|
| String 20 |
|-----------|

NAMM. Middle Name

- Ask for Middle Name but do not probe DK or RF
- If none, PRESS [Enter] to continue
- Ctrl-D and Ctrl-R not allowed; For DK/RF, PRESS [Enter] to continue

| |
|-----------|
| String 20 |
|-----------|

ADDR1. Address 1

- If the mailing address contains both a street address and PO Box: ENTER street address here (Address 1) and ENTER PO Box in Address 2

- Ctrl-D and Ctrl-R not allowed; For DK/RF type [DK] or [RF]

| |
|-----------|
| String 40 |
|-----------|

APTSTE. Apt/Suite

- If none, PRESS [Enter] to continue
- Ctrl-D and Ctrl-R not allowed; For DK/RF, PRESS [Enter] to continue

| |
|-----------|
| String 10 |
|-----------|

ADDR2. Address 2

- If the mailing address contains both a street address and PO Box: ENTER PO Box here (Address 2)
- If none, PRESS [Enter] to continue
- Ctrl-D and Ctrl-R not allowed; For DK/RF, PRESS [Enter] to continue

| |
|-----------|
| String 40 |
|-----------|

| | |
|--|--|
| <p>NAML. Last Name</p> <ul style="list-style-type: none"> Ctrl-D and Ctrl-R not allowed; For DK/RF type [DK] or [RF] <input type="text" value="String 20"/> <p>SUFFIX. Suffix -- e.g. "Sr", "Jr"</p> <ul style="list-style-type: none"> If none, PRESS [Enter] to continue Ctrl-D and Ctrl-R not allowed; For DK/RF, PRESS [Enter] to continue <input type="text" value="String 20"/> <p>INCO. In Care Of</p> <ul style="list-style-type: none"> If none, PRESS [Enter] to continue Ctrl-D and Ctrl-R not allowed; For DK/RF, PRESS [Enter] to continue <input type="text" value="String 40"/> | <p>CITY. City</p> <ul style="list-style-type: none"> Ctrl-D and Ctrl-R not allowed; For DK/RF type [DK] or [RF] <input type="text" value="String 40"/> <p>STATE. State</p> <ul style="list-style-type: none"> Start typing the name of the State to bring up the look-up list If foreign country, ENTER [FOR] to select "Foreign Country" <input type="text" value="String 30; String 4"/> <p>ZIP. Zip Code</p> <ul style="list-style-type: none"> If foreign country, ENTER all [0]'s Ctrl-D and Ctrl-R not allowed; For DK/RF ENTER all [0]'s <input type="text" value="-----"/> <p>COUNTRY. Country if different from USA</p> <ul style="list-style-type: none"> Start typing the name of the Foreign Country to bring up the look-up list <input type="text" value="String 30; String 2"/> |
|--|--|

END RPAY11B

SIGNAL FOR LOCATOR 2:

IWER: Make sure that Helper/Locator's name and address are complete.

Payments will NOT be made to incomplete names or addresses. If any field is Missing/DK/RF, SUSPEND the interview until you have the correct information.

ADDRPAYMENT.L2PHONE

ADDRTYPE. Which Phone

WTRCELL. Does [RPAY11B.NAMF RPAY11B.NAML] have a cell phone?

- Ctrl-D and Ctrl-R not allowed; For DK/RF ENTER [5]

→ GO TO WTRHOME

↓

CELLPH. Cell Phone - Area Code and Telephone Number

What is the area code and phone number?

- If foreign phone, PRESS [ENTER] to go to foreign phone field
- Ctrl-D and Ctrl-R not allowed; For DK/RF, GO BACK and ENTER [5] at WtrCell

→ GO TO CARRIER

↓

CELLFOR. Cell Phone - Foreign Number

(What is the area code and phone number?)

- Ctrl-D and Ctrl-R not allowed; For DK/RF, GO BACK and ENTER [5] at WtrCell

CARRIER. [Cell Phone - Carrier](#)

Which carrier does your cell phone use?

| | | | | | | |
|-------------------|--|-----------------|--------------|--------------|-------------------|-------------|
| 1. Alltel | 2. AT&T | 3. Boost Mobile | 4. Cricket | 5. MetroPCS | 6. Nextel | 7. Ptel |
| 8. Qwest | 9. Sprint | 10. Suncom | 11. T-Mobile | 12. Tracfone | 13. U.S. Cellular | 14. Verizon |
| 15. Virgin Mobile | 97. Other - Specify (CARRIERSPEC. Specify cell phone carrier. (String 20)) | | | | | |

WTRHOME. Does [RPAY11B.NAMF RPAY11B.NAML] have a home phone?

- [Ctrl-D and Ctrl-R not allowed; For DK/RF ENTER \[5\]](#)

1. Yes | 5. No → GO TO WTROTHER

↓

HOMEPH. [Home Phone - Area Code and Telephone Number](#)

What is the area code and phone number?

- [If foreign phone, PRESS \[ENTER\] to go to foreign phone field](#)
- [Ctrl-D and Ctrl-R not allowed; For DK/RF, GO BACK and ENTER \[5\] at WtrHome](#)

[ENTER] | (____)____-____ → GO TO WTROTHER

↓

HOMEFOR. [Home Phone - Foreign Number](#)

(What is the area code and phone number?)

- [Ctrl-D and Ctrl-R not allowed; For DK/RF, GO BACK and ENTER \[5\] at WtrHome](#)

String 20

WTROTHER. Is there any other phone where we can reach [RPAY11B.NAMF RPAY11B.NAML]?

- [Ctrl-D and Ctrl-R not allowed; For DK/RF ENTER \[5\]](#)

1. Yes | 5. No → GO TO RPAY11GG

↓

OTHPH. [Other Phone - Area Code and Telephone Number](#)

What is the area code and phone number?

- [If foreign phone, PRESS \[ENTER\] to go to foreign phone field](#)
- [Ctrl-D and Ctrl-R not allowed; For DK/RF, GO BACK and ENTER \[5\] at WtrOther](#)

[ENTER] | (____)____-____ → GO TO OTHEXT

↓

OTHFOR. [Other Phone - Foreign Number](#)

(What is the area code and phone number?)

- [Ctrl-D and Ctrl-R not allowed; For DK/RF, GO BACK and ENTER \[5\] at WtrOther](#)

String 20

OTHEXT. [Other Phone - Extension](#)

Is there an extension?

- [If none, PRESS \[Enter\] to continue](#)
- [Ctrl-D and Ctrl-R not allowed; For DK/RF, PRESS \[Enter\] to continue](#)

String 20

END L2PHONE

RPAY11GG. What is (his/her) relationship to [HEAD]?

| | | | | | |
|-------------------|------------|--|-----------------|------------|-------------------|
| 1. Mother | 2. Father | 3. Son | 4. Daughter | 5. Sister | 6. Brother |
| 7. Aunt | 8. Uncle | 9. Grandmother | 10. Grandfather | 11. Friend | 12. Father-in-law |
| 13. Mother-in-law | 14. Cousin | 97. Other-Specify (RPAY11GGSPEC. Specify. (String 50)) | | | |

RPAY11H. How much did you offer Locator #2?

| | | |
|------------------------|----------------------------|--|
| 10. Ten dollars (\$10) | 15. Fifteen dollars (\$15) | 20. Twenty dollars (\$20) – with TL approval |
|------------------------|----------------------------|--|

RPAY11I. Can Locator #2 be paid by check or did (he/she) request a money order?

| | | | | |
|--------------|----------------|---------|---------------------|-------|
| 1. Check | 2. Money Order | 3. Cash | 4. Declined payment | DK/RF |
| GO TO RPAY12 | | ↓ | GO TO RPAY12 | |

RPAY11J. When was Locator #2 paid?

- ENTER MM/DD/[CYEAR], with or without slashes

| |
|-------------------|
| __ / __ / [CYEAR] |
|-------------------|

RPAY12. Were there any Respondent or Helper payment problems reported by this Respondent?

| | | |
|--------|-------|--------------------|
| 1. Yes | 5. No | → GO TO IWCOMPLETE |
|--------|-------|--------------------|

↓

RPAY12SPEC. Please provide details of payment issue.

| |
|------------|
| String 500 |
|------------|

END ADDRPAYMENT

Interview Complete

[TOC](#)

IWCOMPLETE. You have reached the end of the Interview.

- ENTER [1] to complete.

1. Interview (Module) Complete

IWPARTIAL. Is this a Completed interview or an [approved](#) Partial interview?

- ENTER [0] for a COMPLETED interview
- ENTER [1005] for a PARTIAL interview

0. Completed IW 1005. Partial IW

SIGNAL FOR IWPARTIAL=1005:

IWER: Are you sure that this is an APPROVED Partial interview?

- If you have approval from your TL to make this a Partial interview, click Suppress to continue
- Otherwise, if this is a Completed interview, click Close and ENTER [0]