

Panel Study of Income Dynamics

Wave 41
2019

The Panel Study of Income Dynamics
The Institute for Social Research
426 Thompson Street
Ann Arbor, MI 48104

Last updated: 5/22/2019

[RP] = proper name of current Reference Person

[SP] = proper name of current Spouse/Partner (of Reference Person)

Table of Contents

Interview Start	3
Family Listing.....	4
Section A: Housing, Utilities, Computer Use.....	18
Section BC: Employment.....	30
Section F: Expenditures.....	57
Section G: Income; OFUM Education	75
Section W: Wealth and Active Savings	133
Section P: Pensions	150
Section H: Health	166
Section J: Marriages and Children	196
Section KL: New RP/SP Background; Returning RP/SP Education	229
Section IMMIG: New Immigrant	254
Section M: Philanthropy	257
Interview Close	261
Address Updates and Payment.....	262
Interview End	290

Interview Start

[TOC](#)

RECORDEDIW Rule: Whether IW Flagged For Recording

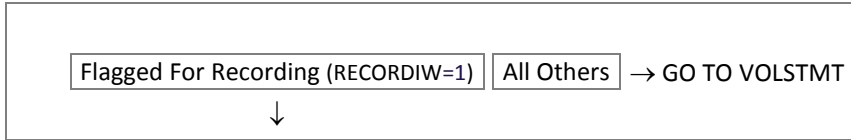

RECORDEDIW_CONSENT. We sometimes record interviews to help us maintain quality. Your interview may be recorded for quality control purposes. Do you agree for this interview to be recorded? You can still participate if you do not want your interview to be recorded.

- If R consents to the RECORDING of this interview, ENTER [1]
- If R does not consent to the RECORDING of this interview, ENTER [5]
- If resuming a suspended interview, RE-READ the consent and ENTER [1] if R consents to the recording or [5] if R does not consent to recording

1. Yes, consent given	5. No, consent not given
-----------------------	--------------------------

VOLSTMT. **VOLUNTARY STATEMENT:** READ to Respondent before the interview begins.

- [*SPANUSED=YES*: USE Ctrl-L to switch between English and Spanish at any point during the interview.]
- Before I begin, I want you to know that this interview is completely voluntary and confidential. In addition, if we come to any question which you don't want to answer, just let me know and we will go on to the next question. The answers that you give will be kept confidential to the maximum extent allowable under federal and state law.
- ENTER [1] to continue
 - If resuming a suspended interview, RE-READ the voluntary statement and ENTER [1] to continue.

1. Continue

Family Listing

[TOC](#)

FU Member Status

COVERSCREEN.CYPERSINFO.CYPINFO [1-24] [1-24]=AQSN of FU member

AQSN. Sequential ID assigned to each FU member

1 – 24

CYFUHU. IWTYPE=REINT & PRELISTED FU

[1st PRELISTED: In [P2YEAR], we had (you/[CYNAMF CYNAML (CYAQRTH)]) listed as living (here / there) as part of the family. Is that still true? / ALL OTHERS: (In [P2YEAR], we had (you/[CYNAMF]) listed as living (here / there) as part of the family.) How about (you/[CYNAMF])? ((Are you/Is [CYNAMF]) currently living (here / there) as part of the family?)]

ALL OTHER IWTYPEs & PRELISTED FU

[1st PRELISTED: Next, I'd like to know who lives (here / there) as part of the family. (Are you/Is [CYNAMF CYNAML]) currently living (here / there) as part of the family? / ALL OTHERS: (Next, I'd like to know who lives (here / there) as part of the family.) How about (you/[CYNAMF])? ((Are you/Is [CYNAMF]) currently living (here / there) as part of the family?)]

PRELISTED INST

Is [CYNAMF CYNAML] still [incarcerated / in a military facility / in an educational facility / in a health facility / in an institutional facility]?

NEW

[1st NEW: Is anyone else currently living (here / there) as part of the family who I did not mention, including any newborn children? / ALL OTHERS: Is anyone else currently living (here / there) as part of the family (who I did not mention,) (including any newborn children?)]

- [PRELISTED: IF NO, change / NEW: IF YES, select and enter] CYFUHU status as follows:
 [PRELISTED INST: 'FU-Mover In' if person has moved back into the Family Unit;]
 [PRELISTED: 'Mover Out' for a person who moved out to another household;
 'Died' if person has died;
 Institution type listed below if person moved to an [institution](#)
 / NEW: 'HU Member w/ Own CS' - HU member listed on their own Reinterview CS
 'HU Member' - Living in HU, but not a member of this FU
 'FU - Mover In' for a new FU Member moved into or born into the Family Unit]
- [NEW: PRESS [Enter] if finished adding family members
- Ctrl-D and Ctrl-R not allowed

PRELISTED	1. FU member	6. Mover Out	7. Died		
	8. Jail	9. Military	10. Education	11. Health	12. Other Inst
NEW	2. HU Member w/Own CS	3. HU member	4. FU Mover In		

*INST 8-12 for FS=YES only;
FS=NO coded as Mover Out*

CYAQRTH. [CYFUHU=PYFUHU: VERIFY or update 'CYAQRTH' if you have a new Reference Person or change in marital status of Reference Person]

- [CYFUHU=HUCS, HU, FUMI: ENTER relationship to current Reference Person / CYFUHU=MO, DIED, INST: DO NOT change 'CYAQRTH' if person moved out, died, or moved to some type of institution]
- Ctrl-D and Ctrl-R not allowed

101 - 982 *SIGNAL for this FU member is a child but not a child of Reference Person or Spouse/Partner (CYFUHU=FU, FUMI & CYAQRTH=601/2, 651/2, 701/2, 711/2, 741/2, 751/2, 951/2, 961/2, 971/2): Remember to VERIFY the parents of this child and the [parents' relationship to the REFERENCE PERSON](#) – you will be asked to record this information in the post-interview observations.*

CYNAMF. [CYFUHU=PYFUHU: FOR pre-listed persons, make any name changes indicated by the Respondent / CYFUHU=HUCS, HU, FUMI: FOR newly listed persons, enter and verify spelling of name]

- Ctrl-D and Ctrl-R not allowed; For DK/RF, type [DK] or [RF]

String 20

CYNAMM. [CYFUHU=PYFUHU: FOR pre-listed persons, make any name changes indicated by the Respondent / CYFUHU=HUCS, HU, FUMI: FOR newly listed persons, enter and verify spelling of name]

- Ask for Middle Name but do not probe DK or RF
- Ctrl-D and Ctrl-R not allowed; For DK/RF, PRESS [Enter] to continue

String 10

CYNAML. [CYFUHU=PYFUHU: FOR pre-listed persons, make any name changes indicated by the Respondent / CYFUHU=HUCS, HU, FUMI: FOR newly listed persons, enter and verify spelling of name]

- [LOOPS 2–24: Not necessary to confirm spelling of last name if it's evident that it's the same as a previous family member]
- If needed, include SUFFIX here (e.g. SR, JR)
- Ctrl-D and Ctrl-R not allowed; For DK/RF, type [DK] or [RF]

String 20 → GO TO CYFUHU For Next FU Member; Then GO TO FAMLISTCONFIRM

FAMLISTCONFIRM. Is the Family Listing Table complete?

- SELECT "YES" and continue OR go back to Family Listing Table

1. Yes

END CYPINFO

Movers-In (FUMI)

MOVEIN Rule: Whether FU Member Moved In Since 1/1/P2YEAR

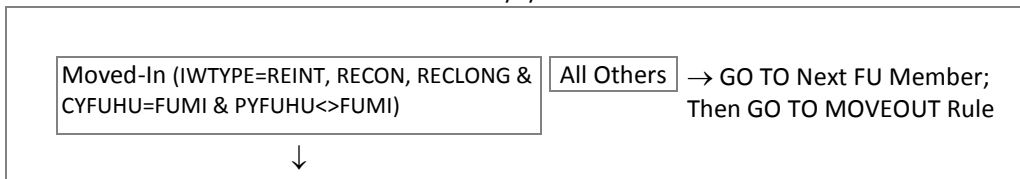

COVERSCREEN.MOVEIN [1-24] [1-24]=AQSN of FU member

MOVEINMO. [REINT: When did [CYNAMF CYNAML] ([CYAQRTH]) move in / RECON, RECLONG: When did [CYNAMF CYNAML] ([CYAQRTH]) start living (here / there) as part of the family?]

- SELECT month moved in
- PROBE DK month: Do you know what season it was?

1. January	2. February	3. March	4. April	5. May	6. June
7. July	8. August	9. September	10. October	11. November	12. December
21. Winter	22. Spring	23. Summer	24. Fall		

MOVEINYR. ([REINT: When did [CYNAMF CYNAML] ([CYAQRTH]) move in? / RECON, RECLONG: When did [CYNAMF CYNAML] ([CYAQRTH]) start living (here / there) as part of the family]?)

- ENTER year moved in
- PROBE /RR/ Move-In years prior to [P2YEAR]

1901 – [CYEAR] → GO TO MOVEIN RULE For Next FU Member; Then GO TO MOVEOUT Rule

END MOVEIN

Movers-Out (MO)

MOVEOUT Rule: Whether FU Member Moved Out Since 1/1/P2YEAR

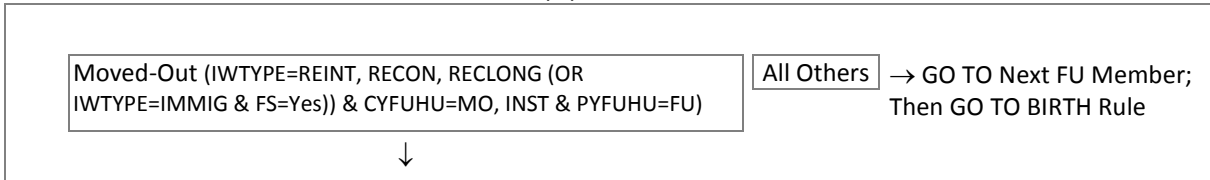
**COVERSCREEN.MOVEOUT [1-24]** [1-24]=AQS_N of FU member

MOVEOUTMO. When did [CYNAMF CYNAML] move out?

- [SELECT month moved out](#)
- [PROBE DK month](#): Do you know what season it was?

1. January	2. February	3. March	4. April	5. May	6. June
7. July	8. August	9. September	10. October	11. November	12. December
21. Winter	22. Spring	23. Summer	24. Fall		

MOVEOUTYR. (When did [CYNAMF CYNAML] move out?)

- [ENTER year moved out](#)
- [PROBE /RR/ Move-Out years prior to \[P2YEAR\]](#)

1901 – [YEAR]

 → GO TO MOVEOUT Rule For Next FU Member; Then GO TO BIRTH Rule
END MOVEOUTBirth Information

BIRTH Rule: Whether FU Member is Living

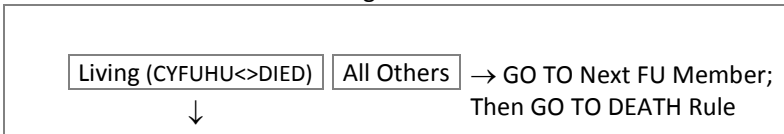
**COVERSCREEN.CYBIRTHINFO.CYBINFO [1-24]** [1-24]=AQS_N of FU member

CYMOBRN. Now, I would like to check some birthdate information.

[PRELOADED DOB=RESPONSE: [VERIFY](#): We have (your / [CYNAMF CYNAML]'s) birthdate as [CYMOBRN / CYDYBRN / CYRBRN]. Is that correct? / PRELOADED DOB=NA & CYFUHU=FU, INST: What is (your / [CYNAMF CYNAML]'s) complete birthdate? / PRELOADED DOB=NA & CYFUHU=HUCS, HU, FUMI: And what is (your / [CYNAMF CYNAML]'s) complete birthdate?]

- [UPDATE or ENTER month](#)

1. January	2. February	3. March	4. April	5. May	6. June
7. July	8. August	9. September	10. October	11. November	12. December

CYDYBRN. ([PRELOADED DOB=RESPONSE: [VERIFY](#): We have (your / [CYNAMF CYNAML]'s) birthdate as [CYMOBRN / CYDYBRN / CYRBRN]. Is that correct? / PRELOADED DOB=NA & CYFUHU=FU, INST: What is (your / [CYNAMF CYNAML]'s) complete birthdate? / PRELOADED DOB=NA & CYFUHU=HUCS, HU, FUMI: And what is (your / [CYNAMF CYNAML]'s) complete birthdate?])

- [UPDATE or ENTER day](#)

1 – 31

CYYRBRN. ([PRELOADED DOB=RESPONSE: VERIFY: We have (your / [CYNAMF CYNAML's]) birthdate as [CYMOBRN / CYDYBRN / CYYRBRN]. Is that correct? / PRELOADED DOB=NA & CYFUHU=FU, INST: What is (your / [CYNAMF CYNAML's]) complete birthdate? / PRELOADED DOB=NA & CYFUHU=HUCS, HU, FUMI: And what is (your / [CYNAMF CYNAML's]) complete birthdate?])

- UPDATE or ENTER year

1880 – [CYEAR]

BIRTH2 Rule: Whether Any Part of Birth Date is Non-Response

CY(MO, DY, YR)BRN=DK/RF	All Others	→ GO TO BIRTH Rule For Next FU Member; Then GO TO DEATH Rule
-------------------------	------------	---

↓

CYESTAGE. Could you tell me how old (you are/he is/she is)?

- IF necessary: What is your best estimate?

1 – 120	→ GO TO BIRTH Rule For Next FU Member; Then GO TO DEATH Rule	DK/RF
---------	---	-------

↓

AGEGE16. VERIFY or ASK: Can you tell me if [CYNAMF CYNAML] is age 16 or older?

1. Yes	5. No	DK/RF NOT ALLOWED
--------	-------	-------------------

GO TO BIRTH Rule For Next FU Member; Then GO TO DEATH Rule

END CYBINFO

Death Information

DEATH Rule: Whether FU Member Has Died

Deceased (CYFUHU=DIED)	All Others	→ GO TO Next FU Member; Then GO TO MARITAL Rule
------------------------	------------	--

↓

COVERSCREEN.CYDEATHINFO.CYDINFO [1-24] [1-24]=AQSN of FU member

CYMOBRN. [You mentioned that [CYNAMF CYNAML] has died. (We are sorry for your loss.) If I may, I have a few questions about (him/her) at this time. / And you mentioned that [CYNAMF CYNAML] has also died.]

[PRELOADED DOB=RESPONSE: VERIFY: We have [CYNAMF CYNAML's] birthdate as [CYMOBRN / CYDYBRN / CYYRBRN]. Is that correct? / PRELOADED DOB=NA: What is [CYNAMF CYNAML's] complete birthdate?]

- UPDATE or ENTER month

1. January	2. February	3. March	4. April	5. May	6. June
7. July	8. August	9. September	10. October	11. November	12. December

CYDYBRN. ([PRELOADED DOB=RESPONSE: VERIFY: We have [CYNAMF CYNAML's] birthdate as [CYMOBRN / CYDYBRN / CYYRBRN]. Is that correct? / PRELOADED DOB=NA: What is [CYNAMF CYNAML's] complete birthdate?])

- UPDATE or ENTER day

1 – 31

CYRBRN. ([PRELOADED DOB=RESPONSE: VERIFY: We have [CYNAMF CYNAML's] birthdate as [CYMOBRN / CYDYBRN / CYRBRN]. Is that correct? / PRELOADED DOB=NA: What is [CYNAMF CYNAML's] complete birthdate?])

- UPDATE or ENTER year

1880 – [CYEAR]

DEATH2 Rule: Whether Any Part of Birth Date is Non-Response

CY(MO, DY, YR)BRN = DK/RF	All Others	→ GO TO BIRTHST
↓		

CYESTAGE. Could you tell me how old (he was/she was)?

- IF necessary: What is your best estimate?

1 – 120

BIRTHST. What state was [CYNAMF CYNAML] born in?

- Start typing the name of the State to bring up the look-up list
- If foreign country, ENTER [FOR] to select "Foreign Country" (Note: Specific Country will not be asked)

String 25

CYMODTH. And what was (his/her) date of death?

- ENTER month

1. January	2. February	3. March	4. April	5. May	6. June
7. July	8. August	9. September	10. October	11. November	12. December

CYDYDTH. (And what was (his/her) date of death?)

- ENTER day

1 – 31

CYIRDTH. (And what was (his/her) date of death?)

- ENTER year

1901 – [CYEAR]

DEATHST. What state was [CYNAMF CYNAML] residing in at the time of (his/her) death?

- Start typing the name of the State to bring up the look-up list
- If foreign country, ENTER [FOR] to select "Foreign Country" (Note: Specific Country will not be asked)

String 25 → GO TO DEATH Rule For Next FU Member; Then GO TO MARITAL Rule

END CYDINFO

Marital Status

MARITAL Rule: Whether FU Member is 15+ Years Old and in the FU

15+ Years Old (AGEIWDATE=15-120 & CYFUHU=FU, FUMI)	All Others	→ GO TO Next FU Member; Then GO TO MSCONFIRM
↓		

COVERSCREEN.MARRSTAT.MSTAT [1-24] [1-24]=AQSN of FU member

MARITAL. [RP/SP LOOP: VERIFY or ASK:] What is (your/[CYNAMF CYNAML's]) current marital status?

(Are you/[Is he / Is she]) now married, widowed, divorced, separated, or (have you/[has he / has she]) never been married?

- If R says Single, PROBE: Does that mean (you are/[he is / she is]) now widowed, divorced, separated, or (have you/[has he / has she]) never been married?

1. Married	2. Never married	3. Widowed	4. Divorced	5. Separated	DK/RF
------------	------------------	------------	-------------	--------------	-------



GO TO MARITAL Rule For Next FU Member; Then GO TO MSCONFIRM

SPOUNAM. [RP/SP LOOP: VERIFY spouse name - Ask R only if you are unclear about the answer: What is (your/[CYNAMF CYNAML's]) spouse's name? / ALL OTHERS: What is (your/[CYNAMF CYNAML's]) spouse's name?]

String 20 → GO TO MARITAL Rule For Next FU Member; Then GO TO MSCONFIRM

MSCONFIRM. Is the Marital Status Information Table complete?

- SELECT "YES" and continue OR go back to Marital Status Information Table

1. Yes

END MSTAT

HU and HUCS Information

HUCS Rule: Whether HU/CS or HU

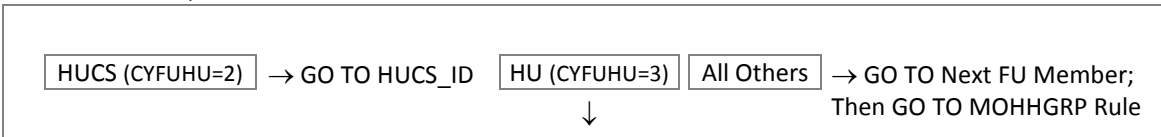
**COVERSCREEN.HUNOTFU [1-24] [1-24]=AQSN of FU member**

HUREASON. SELECT reason(s) why [CYNAMF CYNAML] is not included in this FU.

- ENTER all that apply

1. Has own Coversheet (HU/CS) - Warning: FuHu Status will be permanently changed from HU to HUCS	2. Living with this FU only temporarily	3. Roommate (not related to FU, living in HU as roommate)	4. Refused to be included in the Interview
GO TO HUCS Rule For Next FU Member; Then GO TO MOHHGRP Rule			



END HUNOTFU

COVERSCREEN.HUCSSAMPID.SIDHUCS [1-24] [1-24]=AQSN of FU member

HUCS_ID. REFER to the Family Listing sheet for this 68ID

- ENTER the Sample IDs of all other FU(s) living in this household

String 7 → GO TO HUCS Rule For Next FU Member; Then GO TO MOHHGRP Rule

END HUNOTFU

Movers-Out – Group and Contact Information

MOHHGRP Rule: Whether Any FU Members Moved Out since 1/1/P2YEAR

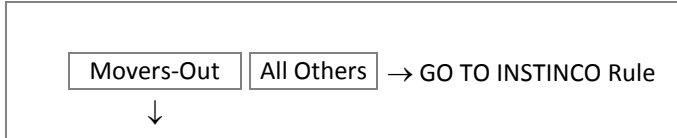

MOHHGRP1. Mover-Out Household Grouping 1

1 MOVER-OUT: Only one person with 'Follow Status = Yes' has moved out of the FU.

- SELECT that person as "MOHHGrp1" and [ENTER] to continue

2 MOVERS-OUT: The following people moved out or are no longer living with (you/the family):

- READ first and last names from answer list below.

Do these two people now live together in the same household? (Which of these people now live together?)

- IF YES: Select these two people into the first grouping (MOHHGrp1), then [ENTER] to continue
- IF NO: Select each person into their own individual groupings (MOHHGrp1, MOHHGrp2))

3+ MOVERS-OUT: The following people moved out or are no longer living with (you/the family):

- READ first and last names from answer list below.

Do any of these [X] people live together in the same household? (Which of these people now live together?)

- IF YES: Select all persons mentioned into the first grouping (MOHHGrp1), then [ENTER] to continue
- IF NO: Select each person into their own individual groupings (MOHHGrp1, MOHHGrp2, etc.)
- Ctrl-D and Ctrl-R not allowed

1 – 24. [CYNAMF CYNAML] [(FS=Yes)] *AQSN list of FU Members if MO*

MOHHGRP[2–8]. Mover-Out Household Grouping [2–8]

1 MOVER-OUT LEFT: Only one Mover-Out remains

- SELECT that person as "MOHHGrp[2–8]" and [ENTER] to continue

2+ MOVERS-OUT LEFT: Do (any of) the other people who moved out now live together?

- IF NECESSARY: READ first and last names from answer list below.
- IF YES: Select all persons mentioned into "MOHHGrp[2–8]", then [ENTER] to continue
- IF NO: Select each person into their own individual groupings (MOHHGrp2, MOHHGrp3, etc.)
- Ctrl-D and Ctrl-R not allowed

1 – 24. [CYNAMF CYNAML] [(FS=Yes)] *AQSN list of FU members if MO*

MOHHGRP2 Rule: Whether Only One Mover-Out Selected For This MOHHGRP

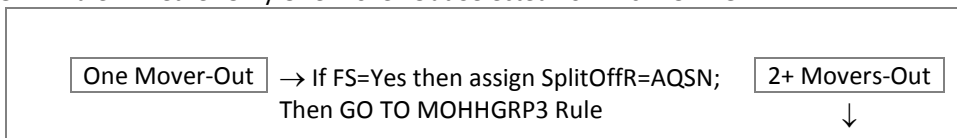

SPLITOFFR[1–8]. SELECT one adult age 18 or older as probable Respondent for this household.

- IF there are no adults (age 18 or older) listed, SELECT oldest child with "FS = YES"

1 – 24. [CYNAMF CYNAML], Age [AGEIWDAT] [(FS=Yes)] *AQSN list of FU Members selected at MOHHGRP*

MOHHGRP3 Rule: Whether There Are More Movers-Out To Be Assigned To A MOHHGRP

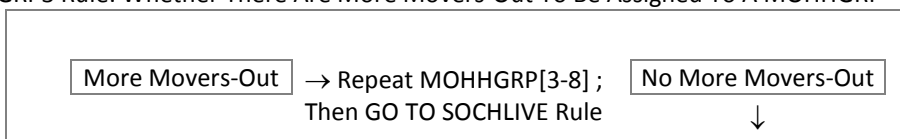

COVERSCREEN.SOCHLIVE [1-8] [1-8]=Which Mover-Out group

SOCHLIVE Rule: Whether SplitOff R is 18+ Years Old



PERSNAMF. Who is [CYNAMF CYNAML] living with now?

String 10

PERSNAML. (Who is [CYNAMF CYNAML] living with now?)

String 15

PERSRTCH. What is (his/her) relationship to [CYNAMF CYNAML]?

String 100

END SOCHLIVE

COVERSCREEN.MOADDRESS [1-8] [1-8]=Which Mover-Out group

<p>MOINCO. Address Update for * Mover Out * <i>[SPLITOFFR<18: SplitOff Child, [CYNAMF CYNAML], is living with [PERSNAMF PERSNAML]]</i> <i>[SPLITOFFR<18: Can you give me [CYNAMF CYNAML]'s new address, I mean the address of the person with whom (he/she) is now living? Is there an "in care of" for the address? / ALL OTHERS: Can you give me [CYNAMF CYNAML's] new address? Is there an "in care of" for the address?]</i></p> <ul style="list-style-type: none"> • ATTACH comment to any item using [F2] • If none, PRESS [Enter] to continue • Ctrl-D and Ctrl-R not allowed; For DK/RF, PRESS [Enter] to continue <p style="border: 1px solid black; padding: 2px 5px;">String 40</p> <p>MOADDR1. Address Update for * Mover Out * <i>[SplitOff Child, [CYNAMF CYNAML], is living with [PERSNAMF PERSNAML]]</i> What is the street address?</p> <ul style="list-style-type: none"> • ATTACH comment to any item using [F2] • If there is a street address and a PO Box, ENTER PO Box here (ENTER street address in the Address 2 field) • Ctrl-D and Ctrl-R not allowed; For DK/RF type [DK] or [RF] <p style="border: 1px solid black; padding: 2px 5px;">String 40</p> <p>MOAPTSTE. Address Update for * Mover Out * <i>[SplitOff Child, [CYNAMF CYNAML], is living with [PERSNAMF PERSNAML]]</i> (Is there an apartment or suite number?)</p> <ul style="list-style-type: none"> • ATTACH comment to any item using [F2] • If none, PRESS [Enter] to continue 	<p>MOADDR2. Address Update for * Mover Out * <i>[SplitOff Child, [CYNAMF CYNAML], is living with [PERSNAMF PERSNAML]]</i> (What is the street address?)</p> <ul style="list-style-type: none"> • ATTACH comment to any item using [F2] • If there is a street address and a PO Box, ENTER street address here (ENTER PO Box in Address1 field) • If none, PRESS [Enter] to continue • Ctrl-D and Ctrl-R not allowed; For DK/RF, PRESS [Enter] to continue <p style="border: 1px solid black; padding: 2px 5px;">String 40</p> <p>MOCITY. Address Update for * Mover Out * <i>[SplitOff Child, [CYNAMF CYNAML], is living with [PERSNAMF PERSNAML]]</i> What is the City?</p> <ul style="list-style-type: none"> • ATTACH comment to any item using [F2] • Ctrl-D and Ctrl-R not allowed; For DK/RF type [DK] or [RF] <p style="border: 1px solid black; padding: 2px 5px;">String 40</p> <p>MOSTATE. Address Update for * Mover Out * <i>[SplitOff Child, [CYNAMF CYNAML], is living with [PERSNAMF PERSNAML]]</i> What is the State?</p> <ul style="list-style-type: none"> • ATTACH comment to any item using [F2] • Start typing the name of the State to bring up the look-up list • If foreign country, ENTER [FOR] to select "Foreign Country" <p style="border: 1px solid black; padding: 2px 5px;">String 30; String 4</p>
--	--

<ul style="list-style-type: none"> Ctrl-D and Ctrl-R not allowed; For DK/RF, PRESS [Enter] to continue <p>String 10</p>	<p>ZIP. MOZIP. Address Update for * Mover Out * [SplitOff Child, [CYNAMF CYNAML], is living with [PERSNAMF PERSNAML]] What is the Zip code?</p> <ul style="list-style-type: none"> ATTACH comment to any item using [F2] If foreign country, ENTER all [0]'s Ctrl-D and Ctrl-R not allowed; For DK/RF ENTER all [0]'s <p>-----</p> <p>MOCOUNTRY. Address Update for * Mover Out * [SplitOff Child, [CYNAMF CYNAML], is living with [PERSNAMF PERSNAML]] IF other than USA: What is the Country?</p> <ul style="list-style-type: none"> ATTACH comment to any item using [F2] Start typing the name of the Foreign Country to bring up the look-up list <p>String 30; String 2</p>
--	--

<p>WTRCELL. Cell Phone for * Mover Out * [SPLITOFFR<18: SplitOff Child, [CYNAMF CYNAML], is living with [PERSNAMF PERSNAML]] Does [SPLITOFFR=18+: [CYNAMF CYNAML] / SPLITOFFR<18: [PERSNAMF PERSNAML]] have a <u>cell</u> phone?</p> <ul style="list-style-type: none"> Ctrl-D and Ctrl-R not allowed; For DK/RF ENTER [5] <p>1. Yes 5. No → GO TO WTRHOME</p> <p>↓</p> <p>CELLPH. Cell Phone for * Mover Out * [SplitOff Child, [CYNAMF CYNAML], is living with [PERSNAMF PERSNAML]] What is the area code and phone number?</p> <ul style="list-style-type: none"> If foreign phone, PRESS [ENTER] to go to foreign phone field Ctrl-D and Ctrl-R not allowed; For DK/RF, GO BACK and ENTER [5] at WtrCell <p>[ENTER] (____)____-_____ → GO TO WTRHOME</p> <p>↓</p> <p>CELLFOR. Cell Phone for * Mover Out * [SplitOff Child, [CYNAMF CYNAML], is living with [PERSNAMF PERSNAML]] (What is the area code and phone number?)</p> <ul style="list-style-type: none"> Ctrl-D and Ctrl-R not allowed; For DK/RF, GO BACK and ENTER [5] at WtrCell <p>String 20</p>	<p>WTRHOME. Home Phone for * Mover Out * [SplitOff Child, [CYNAMF CYNAML], is living with [PERSNAMF PERSNAML]] Does [[CYNAMF CYNAML] / [PERSNAMF PERSNAML]] have a <u>home</u> phone?</p> <ul style="list-style-type: none"> Ctrl-D and Ctrl-R not allowed; For DK/RF ENTER [5] <p>1. Yes 5. No → GO TO MOEMAIL Rule</p> <p>↓</p> <p>HOMEPH. Home Phone for * Mover Out * [SplitOff Child, [CYNAMF CYNAML], is living with [PERSNAMF PERSNAML]] What is the area code and phone number?</p> <ul style="list-style-type: none"> If foreign phone, PRESS [ENTER] to go to foreign phone field Ctrl-D and Ctrl-R not allowed; For DK/RF, GO BACK and ENTER [5] at WtrHome <p>[ENTER] (____)____-_____ → GO TO MOEMAIL Rule</p> <p>↓</p> <p>HOMEFOR. Home Phone for * Mover Out * [SplitOff Child, [CYNAMF CYNAML], is living with [PERSNAMF PERSNAML]] (What is the area code and phone number?)</p> <ul style="list-style-type: none"> Ctrl-D and Ctrl-R not allowed; For DK/RF, GO BACK and ENTER [5] at WtrHome <p>String 20</p>
---	--

MOEMAIL Rule: Whether SplitOff R is 18+ Years Old

18+ Years Old (AGEIWDATE=18+)	Less than 18 Years Old (AGEIWDATE<18)	→ GO TO SOMARST Rule
↓		

MOEMAIL. [Address Update for * Mover Out *](#)

Is there an e-mail address where we can contact [CYNAMF CYNAML]?

1. Yes 5. No → GO TO SOMARSTAT Rule

↓

MOEMAILADDR. [Address Update for * Mover Out *](#)

(What is that e-mail address?)

- ENTER email address, then READ BACK and VERIFY with Respondent
- Ctrl-D and Ctrl-R not allowed; For DK/RF go back and ENTER [Ctrl-D, Ctrl-R] at previous question

String 50

MOEMAIL2. [Address Update for * Mover Out *](#)

Is there another e-mail address where we can contact [CYNAMF CYNAML]?

1. Yes 5. No → GO TO SOMARSTAT Rule

↓

MOEMAIL2ADDR. [Address Update for * Mover Out *](#)

(What is that e-mail address?)

- ENTER email address, then READ BACK and VERIFY with Respondent
- Ctrl-D and Ctrl-R not allowed; For DK/RF go back and ENTER [Ctrl-D, Ctrl-R] at previous question

String 50

END MOADDRESS

COVERSCREEN.SOMARSTAT [1-8] [1-8]=Which Mover-Out group

SOMARST Rule: Whether SplitOff R is 18+ Years Old

18+ Years Old (AGEIWDATE=18+)	Less than 18 Years Old (AGEIWDATE<18)	→ GO TO DIFFPANFU
↓		

SOMARST. Is [he / she] married, widowed, divorced, separated, or never married?

1. Married 2. Never married 3. Widowed 4. Divorced 5. Separated DK/RF

↓

GO TOLIVOWNHH

SPOUNAMF. [*MO=PRELOADED RP/SP: VERIFY spouse name - Ask R only if you are unclear about the answer:*] What is [CYNAMF CYNAML]'s spouse's name?

String 20

SPOUNAML. [*MO=PRELOADED RP/SP: VERIFY spouse name - Ask R only if you are unclear about the answer:*] What is [CYNAMF CYNAML]'s spouse's name?

String 25

LIVOWNHH. Have they set up their own household, have they moved in with another FES (Family Economics Study) family, or have they moved in with a family not in FES?

- BY 'Set up their own household', we mean they are financially independent.
- IF R says "Living with someone else", PROBE: Is that with another FES (Family Economics Study) family, a family not in FES, or have they set up their own household?
- Ctrl-D and Ctrl-R not allowed

1. Yes, set-up own household GO TO SOCHLIVE Rule For Next MOHHGRP; Then GO TO INST Rule	2. Moved to a household not in study	3. Moved to an institution (military, education, health, other institution)	4. Moved to a household in study
---	--------------------------------------	---	----------------------------------



CHECK for LIVOWNHH=3 & CYFUHU = M_O: You have selected "Moved to an institution" which is not valid for a FU Member who has been coded as Mover-Out in the family listing. If this FU Member is not a Mover-out, select GOTO to go back to the family listing and enter the correct FU/HU code.

PERSNAMF. Who is [CYNAMF CYNAML] living with now?

String 10

PERSNAML. (Who is [CYNAMF CYNAML] living with now?)

String 15

PERSRTCH. What is (his/her) relationship to [CYNAMF CYNAML]?

String 100

END SOMARSTAT

COVERSCREEN.SOCHOTHFU [1-8] [1-8]=Which Mover-Out group

SIDMOVE Rule: Whether MOHHGRP Moved in with a PSID Family

Moved To PSID Family (LIVOWNHH=4)	All Others	→ GO TO SOCHLIVE Rule For Next MOHHGRP; Then GO TO INST Rule
-----------------------------------	------------	---

↓

SIDMOVE. ENTER Sample ID of the family unit into which [CYNAMF CYNAML] has moved.

String 7 → GO TO SOCHLIVE RULE For Next MOHHGRP; Then GO TO INST RULE

DIFPANFU. Has SplitOff moved to another household in the Family Economics Panel Study?

- CHECK Family Listing Sheets for this 68ID

1. Yes, moved to another FU in study	5. No, moved to a household <u>not</u> in the study	→ GO TO SOCHLIVE Rule For Next MOHHGRP; Then GO TO INST Rule
--------------------------------------	---	--

↓

SIDMOVE. ENTER Sample ID of the family unit into which [CYNAMF CYNAML] has moved.

String 7 → GO TO SOCHLIVE Rule For Next MOHHGRP; Then GO TO INST Rule

END SOCHOTHFU

Institutional Contact Information

INST Rule: Whether Any FU Member Moved to Institution

<div style="border: 1px solid black; padding: 2px; display: inline-block;">Institutional (REINT/RECON & FS=Yes & CYFUHU=INST & PYFUHU=FU)</div> <div style="border: 1px solid black; padding: 2px; display: inline-block; margin-left: 10px;">All Others</div> → GO TO Next FU Member; Then GO TO RSELECT
↓

COVERSCREEN.INSTADDRESS [1-24] [1-24]=AQSN of FU member

<p>INSTINCO. Address Update for Institutional *[Prison / Military / Education / Health / Other]* <i>[INST<18: Institutional is a Child, [CYNAMF CYNAML]]</i> Can you give me [CYNAMF CYNAML]'s address and phone number? Is there an "in care of" for the address</p> <ul style="list-style-type: none"> • ATTACH comment to any item using [F2] • If none, PRESS [Enter] to continue • Ctrl-D and Ctrl-R not allowed; For DK/RF, PRESS [Enter] to continue <div style="border: 1px solid black; padding: 2px; width: fit-content;">String 40</div> <p>INSTADDR1. Address Update for Institutional *[Prison / Military / Education / Health / Other]* <i>[Institutional is a Child, [CYNAMF CYNAML]]</i> What is the street address?</p> <ul style="list-style-type: none"> • ATTACH comment to any item using [F2] • If there is a street address and a PO Box, ENTER PO Box here (ENTER street address in the Address 2 field) • Ctrl-D and Ctrl-R not allowed; For DK/RF type [DK] or [RF] <div style="border: 1px solid black; padding: 2px; width: fit-content;">String 40</div> <p>INSTAPTSTE. Address Update for Institutional *[Prison / Military / Education / Health / Other]* <i>[Institutional is a Child, [CYNAMF CYNAML]]</i> (Is there an apartment or suite number?)</p> <ul style="list-style-type: none"> • ATTACH comment to any item using [F2] • If none, PRESS [Enter] to continue • Ctrl-D and Ctrl-R not allowed; For DK/RF, PRESS [Enter] to continue <div style="border: 1px solid black; padding: 2px; width: fit-content;">String 10</div> <p>INSTADDR2. Address Update for Institutional *[Prison / Military / Education / Health / Other]* <i>[Institutional is a Child, [CYNAMF CYNAML]]</i> (What is the street address?)</p> <ul style="list-style-type: none"> • ATTACH comment to any item using [F2] • If there is a street address and a PO Box, ENTER street address here (ENTER PO Box in Address1 field) • If none, PRESS [Enter] to continue • Ctrl-D and Ctrl-R not allowed; For DK/RF, PRESS [Enter] to continue <div style="border: 1px solid black; padding: 2px; width: fit-content;">String 40</div>	<p>INSTCITY. Address Update for Institutional *[Prison / Military / Education / Health / Other]* <i>[Institutional is a Child, [CYNAMF CYNAML]]</i> What is the City?</p> <ul style="list-style-type: none"> • ATTACH comment to any item using [F2] • Ctrl-D and Ctrl-R not allowed; For DK/RF type [DK] or [RF] <div style="border: 1px solid black; padding: 2px; width: fit-content;">String 40</div> <p>INSTSTATE. Address Update for Institutional *[Prison / Military / Education / Health / Other]* <i>[Institutional is a Child, [CYNAMF CYNAML]]</i> What is the State?</p> <ul style="list-style-type: none"> • ATTACH comment to any item using [F2] • Start typing the name of the State to bring up the look-up list • If foreign country, ENTER [FOR] to select "Foreign Country" <div style="border: 1px solid black; padding: 2px; width: fit-content;">String 30; String 4</div> <p>INSTZIP. Address Update for Institutional *[Prison / Military / Education / Health / Other]* <i>[Institutional is a Child, [CYNAMF CYNAML]]</i> What is the Zip code?</p> <ul style="list-style-type: none"> • ATTACH comment to any item using [F2] • If foreign country, ENTER all [0]'s • Ctrl-D and Ctrl-R not allowed; For DK/RF ENTER all [0]'s <div style="border: 1px solid black; padding: 2px; width: fit-content;">_ _ _ _ _ - _ _ _ _ _</div> <p>INSTCOUNTRY. Address Update for Institutional *[Prison / Military / Education / Health / Other]* <i>[Institutional is a Child, [CYNAMF CYNAML]]</i> IF other than USA: What is the Country?</p> <ul style="list-style-type: none"> • ATTACH comment to any item using [F2] • Start typing the name of the Foreign Country to bring up the look-up list <div style="border: 1px solid black; padding: 2px; width: fit-content;">String 30; String 2</div>
---	---

<p>WTRCELL. Cell Phone for Institutional *[Prison / Military / Education / Health / Other]* [INST<18: Institutional is a Child, [CYNAMF CYNAML]] [INST=18+: Does [CYNAMF CYNAML] have a <u>cell</u> phone / INST<18: Is there a <u>cell</u> phone where we can contact [CYNAMF CYNAML]]? • Ctrl-D and Ctrl-R not allowed; For DK/RF ENTER [5]</p> <p>1. Yes 5. No → GO TO WTRHOME</p> <p>↓</p> <p>CELLPH. Cell Phone for Institutional *[Prison / Military / Education / Health / Other]* [Institutional is a Child, [CYNAMF CYNAML]] What is the area code and phone number? • If foreign phone, PRESS [ENTER] to go to foreign phone field • Ctrl-D and Ctrl-R not allowed; For DK/RF, GO BACK and ENTER [5] at WtrCell</p> <p>[ENTER] (_ _) _ _ - _ _ _ _ → GO TO WTRHOME</p> <p>↓</p> <p>CELLFOR. Cell Phone for Institutional *[Prison / Military / Education / Health / Other]* [Institutional is a Child, [CYNAMF CYNAML]] (What is the area code and phone number?) • Ctrl-D and Ctrl-R not allowed; For DK/RF, GO BACK and ENTER [5] at WtrCell</p> <p>String 20</p>	<p>WTRHOME. Home Phone for Institutional *[Prison / Military / Education / Health / Other]* [Institutional is a Child, [CYNAMF CYNAML]] [Does [CYNAMF CYNAML] have a <u>home</u> phone / Is there a <u>home</u> phone where we can contact [CYNAMF CYNAML]]? • Ctrl-D and Ctrl-R not allowed; For DK/RF ENTER [5]</p> <p>1. Yes 5. No → GO TO INSTEMAIL Rule</p> <p>↓</p> <p>HOMEPH. Home Phone for Institutional *[Prison / Military / Education / Health / Other]* [Institutional is a Child, [CYNAMF CYNAML]] What is the area code and phone number? • If foreign phone, PRESS [ENTER] to go to foreign phone field • Ctrl-D and Ctrl-R not allowed; For DK/RF, GO BACK and ENTER [5] at WtrHome</p> <p>[ENTER] (_ _) _ _ - _ _ _ _ → GO TO INSTEMAIL Rule</p> <p>↓</p> <p>HOMEFOR. Home Phone for Institutional *[Prison / Military / Education / Health / Other]* [Institutional is a Child, [CYNAMF CYNAML]] (What is the area code and phone number?) • Ctrl-D and Ctrl-R not allowed; For DK/RF, GO BACK and ENTER [5] at WtrHome</p> <p>String 20</p>
---	---

INSTEMAIL Rule: Whether Institutional Is 18+ Years Old

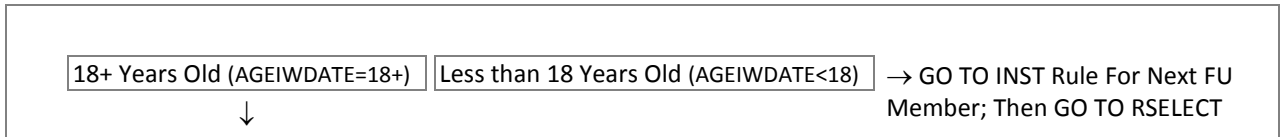

INSTEMAIL. Address Update for Institutional *[Military / Education / Health / Other]*

Is there an e-mail address where we can contact [CYNAMF CYNAML]?

1. Yes | 5. No → GO TO INST Rule For Next FU Member; Then GO TO RSELECT



INSTEMAILADDR. Address Update for Institutional *[Military / Education / Health / Other]*

(What is that e-mail address?)

- ENTER email address, then READ BACK and VERIFY with Respondent
- Ctrl-D and Ctrl-R not allowed; For DK/RF go back and ENTER [Ctrl-D, Ctrl-R] at previous question

String 50

INSTEMAIL2. Address Update for Institutional *[Military / Education / Health / Other]*

Is there another e-mail address where we can contact [CYNAMF CYNAML]?

1. Yes | 5. No → GO TO INST Rule For Next FU Member; Then GO TO RSELECT



INSTEMAIL2ADDR. Address Update for Institutional *[Military / Education / Health / Other]*

(What is that e-mail address?)

- ENTER email address, then READ BACK and VERIFY with Respondent
- Ctrl-D and Ctrl-R not allowed; For DK/RF go back and ENTER [Ctrl-D, Ctrl-R] at previous question

String 50 → GO TO INST Rule For Next FU Member; Then GO TO RSELECT

END INSTADDRESS

Respondent Selection and FU Confirmation

RSELECT. SELECT Respondent from list of FU Members below or enter Code 97 for Proxy Respondent

- NOTE: Proxy Respondent is any person who is not a member of this FU

1 – 24. [CYNAMF CYNAML], [CYAQRTH], [CYFUHU] *AQSN list of current RP, current SP, & current OFUMs age 18+*

97. Proxy Respondent-Specify (RSELECTSPEC. Please specify relationship to Reference Person and the Proxy's name (String 100))

SIGNAL FOR RSELECT=RP, SP age<18: This person is less than 18 years old. SUSPEND this interview and contact your TL before continuing.

FUFINALCONFIRM. Review the family listing with Respondent. If necessary, go back to make changes. Once past this screen, [you will not be able to go back to the Family Listing](#)

Respondent: [FNAME LNAME]

Relationship to Reference Person: [CYAQRTH]

FU Status: [CYFUHU]

1 – 24. [CYNAMF CYNAML], [CYAQRTH], [CYFUHU], [MARITAL], Birthdate: [DOB] *[AQSN list of FU Members]*

- ENTER [1] to confirm family listing and continue

1. Confirm → GO TO SECTION A

END COVERSCREEN

Section A: Housing, Utilities, Computer Use

[TOC](#)

SECTION_A

A3CKPT. CAI Checkpoint: Who is Respondent

1. R=Reference Person, Spouse/Partner (RESPONDENT=1, 2, 3)	5. R=OFUM, Proxy (RESPONDENT=4, 7)
↓	
GO TO A4	

A3. Please think about your life-as-a-whole. How satisfied are you with it? Are you completely satisfied, very satisfied, somewhat satisfied, not very satisfied, or not at all satisfied?

1. Completely satisfied	2. Very satisfied	3. Somewhat satisfied	4. Not very satisfied	5. Not at all satisfied
-------------------------	-------------------	-----------------------	-----------------------	-------------------------

A4. Do you live in a one-family house, a two-family house, an apartment, a mobile home, or what?

- IF R answers "condo," PROBE for the physical structure of the condo: We are looking for the physical structure of your condo. Is it a free standing home, attached to others, or part of a multi-unit building?

1. One-family house	2. Two-family house or duplex	3. Apartment in a multi-unit building; project
4. Mobile home or trailer	6. Row or town house	7. Other-specify (A4SPEC. Please specify. (String 100))

A5CKPT. CAI Checkpoint: Whether Reference Person or Spouse/Partner is Age 55+

1. Reference Person, Spouse/Partner is Age 55+ (AGEIWDATE=55-120)	5. All Others	→ GO TO A8
↓		

A6A. Some places require at least one family member to be 55 years or older. Is the place you live like that?

1. Yes	5. No	→ GO TO A8
--------	-------	------------

↓

A7A Rule: Whether FU Lives In Apartment/Project or Other

Apartment/Project, Other (A4=3, 7)	All Others	→ GO TO A8
↓		

A7A. Sometimes places offer services that help with daily activities, such as help with bathing or dressing, group meals, or handling medications. Does the place you live offer services like that?

1. Yes	5. No
--------	-------

A8. [R=RP, SP, OFUM: For these next questions, when I refer to "family", I mean your family living there with you.] How many rooms do you have [for your family] not counting bathrooms?

- [HU/CS IN FU: Remind R not to include rooms used by HU or HUCS people]
- ENTER [1 -19] for Actual number of rooms;
- ENTER [20] for Twenty or more rooms;
- ENTER [0] if FU shares a one-room HU with non-FU persons

0 - 20

A19. Do you [or anyone else in your family living there] own the [A4=APT: apartment / A4=MOBILE: mobile home / ALL OTHERS: home], do you pay rent, or what?

- If R says “coop, cooperative”, PROBE: Are you a shareholder - do you have a purchase agreement - in the cooperative, or do you have a lease agreement?
 - If SHAREHOLDER/PURCHASE agreement or Don't Know, ENTER [1]
 - If LEASE agreement, ENTER [5]

1. Any FU member owns or is buying (fully or jointly)	5. FU pays rent	8. FU neither owns nor rents
	GO TO A31	GO TO A34



Owners (A19=1)

A20. Could you tell me what the present value of your [apartment / mobile home / home] is [A4=MOBILE: including the value of the lot if you own the lot] - I mean about how much would it bring if you sold it today?

\$ 0 – 9,999,997 → GO TO A20A1	DK/RF
--------------------------------	-------



A20A. Would it amount to \$200,000 or more?					
1. Yes	5. No		DK/RF → GO TO A20A1		
↓	↓				
A20B. (Would it amount to)		A20D. (Would it amount to)			
\$300,000 or more?		\$100,000 or more?			
1. Yes	5. No	DK/RF	1. Yes	5. No	DK/RF
↓	GO TO A20A1		GO TO A20A1	↓	GO TO A20A1
A20C. (Would it amount to)			A20E. (Would it amount to)		
\$500,000 or more?			\$50,000 or more?		
1. Yes	5. No	DK/RF	1. Yes	5. No	DK/RF

A20A1. If someone were to rent this [apartment/mobile home/home] today, how much do you think it would rent for per month, unfurnished and without utilities?

- ENTER amount here, then SELECT unit of time on next screen (Week, Month, Year)

\$ 1 – 99,997	DK/RF	→ GO TO A20F RULE
---------------	-------	-------------------



A20A1PER. The rent amount entered is: [A20A1] per ____

- SELECT the unit of time below

3. Week	5. Month	6. Year	7. Other-specify (A20A1PERSPEC. Specify. (String 100))
---------	----------	---------	--

A20F Rule: Whether FU Lives In Mobile Home

Mobile Home (A4=4)	All Others	→ GO TO A21
↓		

A20F. Do you rent the lot (where your mobile home is located)?

1. Yes 5. No → GO TO A21



A20G. How much do you pay to rent the lot?

- ENTER amount here, then SELECT unit of time on next screen (Week, Two weeks, Month, Year)

→ GO TO A20H



A20GPER. The amount entered is: [A20G] per _____

- SELECT the unit of time below

A20H. Does [A20G=DK/RF: the lot rent / ALL OTHERS: this amount] include water and sewer?

1. Yes 5. No

A21. About how much are your total yearly property taxes, including city, county, and school taxes?

A22. How much is your total yearly homeowner's insurance premium?

Mortgages

SECTION_A.MGTE [1-2] [1]=1st mortgage, [2]=2nd mortgage

A23. Do you have a mortgage or loan on this property?

- If R says more than one mortgage or loan: Please tell me about the one (mortgage or loan) you've had the longest

→ GO TO A37FOR



A23A. [1ST MTGE: Is that a mortgage, a land contract, a home equity loan, or what? / 2nd MTGE: For the second mortgage, what type of loan is that?]



GO TO A24

A23B. Is that the original loan and terms, or have you refinanced?

A24. About how much is the remaining principal on this loan?

A25. How much are your monthly loan payments?

A25A1. Does this amount include property taxes?

1. Yes 5. No

A25A2. Does it (this mortgage or loan payment) include insurance premiums?

1. Yes 5. No

A25A3. Is the interest rate on that mortgage or loan fixed or variable?

1. Fixed 2. Variable

A25A4. What is the current interest rate on that loan?

- ENTER the whole number portion and then ENTER the fraction portion at the next screen.

0 – 65 DK/RF → GO TO A26



SIGNAL for A25A4=25-65: You have entered interest rate = [A25A4] %. If this is not correct, go back to A25A4 and enter correct amount. If this is correct, click [SUPPRESS] to continue.

A25B. (What is the current interest rate on that loan?)

- The whole number amount entered is: [A25A4]. ____ %
- SELECT the fraction portion of the mortgage rate below

0. [A25A].0	1. [A25A] 1/8 or [A25A].125
2. [A25A] 1/4 or [A25a].25	3. [A25A] 3/8 or [A25A].375
4. [A25A] 1/2 or [A25A].5	5. [A25A] 5/8 or [A25A].625
6. [A25A] 3/4 or [A25A].75	7. [A25A] 7/8 or [A25A].875
8. Other-specify (A25BSPEC. Please specify. (String 100))	

A26. What year did you [A23B=REFINANCED: (last) refinance / ALL OTHERS: obtain that loan?

1901 – [CYEAR]

A27. About how many more years will you have to pay on it?

1 – 97

Foreclosure

A27A. [1ST MTGE: Some people have had difficulties recently making their mortgage or loan payments.

Are you [or anyone in your family living there], currently behind on your [A23A=MTGE: mortgage / ALL OTHERS: loan] payments? / 2nd MTGE: (Some people have had difficulties recently making their mortgage or loan payments.) Are you [or anyone in your family living there], currently behind on your [A23A=MTGE: mortgage / ALL OTHERS: loan] payments (for this [A23A=MTGE: mortgage / ALL OTHERS: loan])?)

1. Yes 5. No → GO TO A27F



A27B. How many months are you behind?

1 – 97

A27C. Has your bank or lender started the process of foreclosing on your home?

1. Yes 5. No → GO TO A27F



A27D. In what month and year did the foreclosure start?

- SELECT Month and [Enter] to go to next screen for year
- IF NECESSARY: What would be your best estimate?

1. January	2. February	3. March	4. April
5. May	6. June	7. July	8. August
9. September	10. October	11. November	12. December
21. Winter	22. Spring	23. Summer	24. Fall

A27E. (In what month and year did the foreclosure start?)

[A27D], _____

- ENTER Year: [[P2YEAR] / [P4YEAR] / 2001] – [CYEAR]

REINT, RECLONG

RECON

ALL OTHERS

A27F. Have you worked with your bank or lender to restructure or modify your [A23A=MTGE: mortgage / ALL OTHERS: loan] [A27A=YES: because of missed payments]?

1. Yes 5. No

A27G. How likely is it that you [A27A=YES: will continue to be behind / ALL OTHERS: will fall behind] on your [A23A=MTGE: mortgage / ALL OTHERS: loan] payments in the next 12 months? Would you say very likely, somewhat likely, or not likely at all?

1. Very likely 3. Somewhat likely 5. Not likely at all

A28. Do you also have a second mortgage on this property?

1. Yes → Repeat A23A-A27G; MAX=2; 5. No → GO TO A37FOR
Then GO TO A37FOR

END MGTE

Renters (A19=5)

A31. About how much rent do you pay a month [A4=MOBILE: , including rent for the lot]?

- [HU/CS IN FU: IF FU lives with non-FU members, PROBE: Is that only for your (FU's) share of the rent?]
- [A4=MOBILE: If FU owns the lot, do not include the value of the lot]
- ENTER amount here, then SELECT unit of time on next screen (Week, Two weeks, Month, Year)

→ GO TO A31A RULE



A31PER. The rent amount entered is: [A31] per _____

- SELECT the unit of time below

3. Week 4. Two weeks 5. Month 6. Year

7. Other-specify (A31PERSPEC. Specify. (String 100))

A31A Rule: Whether FU Lives In Mobile Home

Mobile Home (A4=4)	All Others	→ GO TO A31B
--------------------	------------	--------------

↓

A31A. Does [A31=DK/RF: the rent / ALL OTHERS: this amount] include water and sewer?

1. Yes	5. No
--------	-------

A31B. Is this [apartment / mobile home / home] rented fully furnished?

1. Yes	5. No
--------	-------

A31C. Is heating included in your monthly rent?

1. Yes	5. No
--------	-------

A32. Is this [apartment / mobile home / home] in a public housing project, that is, is it owned by a local housing authority or other public agency?

1. Yes	→ GO TO A37FOR	5. No
--------	----------------	-------



A33. Does a federal, state, or local government housing program pay part of your rent?

(\$[A31] per [A31PER])

1. Yes	5. No
--------	-------

GO TO A37FOR

Neither Owns nor Rents (A19=8)

A34. How is that? (Could you tell me a little more about your situation?)

String 400

A35. How much would it rent for if it were rented?

- [HU/CS IN FU: IF FU lives with non-FU members, PROBE: Would that be only for your (FU's) share of the rent?]
- ENTER amount here, then SELECT unit of time on next screen (Week, Two weeks, Month, Year)

\$ 1 – 9,997	DK/RF	→ GO TO A36
--------------	-------	-------------



A35PER. The rent amount entered is: [A35] per ____

- SELECT the unit of time below

3. Week	4. Two weeks	5. Month	6. Year
---------	--------------	----------	---------

7. Other-specify (A35PERSPEC. Specify. (String 100))
--

A36. Is this [apartment / mobile home / home] in a public housing project, that is, is it owned by a local housing authority or other public agency?

1. Yes	→ GO TO A37FOR	5. No
--------	----------------	-------



A37. Are you paying no rent because a Federal, State, or local government housing program is paying all of it?

1. Yes	5. No
--------	-------

Past Foreclosure

SECTION_A.A37FOR [1]

A37A. *A27C=FORECLOSURE STARTED*: [*REINT, RECLONG*: Other than the foreclosure experience we just talked about, since our last interview in [P2YEAR] [*PYIWDATE=RESPONSE*: ([PYIWDATE])], have you [or anyone in your family living there] had a home on which a foreclosure was started? / *RECON*: Other than the foreclosure experience we just talked about, since our last interview in [P4YEAR] [*PYIWDATE=RESPONSE*: ([PYIWDATE])], have you [or anyone in your family living there] had a home on which a foreclosure was started? / *ALL OTHERS*: Other than the foreclosure experience we just talked about, since January 1, 2001, have you [or anyone in your family living there] had a home on which a foreclosure was started?]

A27C=ALL OTHERS: [*REINT, RECLONG*: Since our last interview in [P2YEAR] [[PYIWDATE]], have you [or anyone in your family living there] had a home on which a foreclosure was started? / *RECON*: Since our last interview in [P4YEAR] [[PYIWDATE]], have you [or anyone in your family living there] had a home on which a foreclosure was started? / *ALL OTHERS*: Since January 1, 2001, have you [or anyone in your family living there] had a home on which a foreclosure was started?]

1. Yes 5. No → GO TO A42



A37B. In what month and year did the foreclosure start?

- **SELECT Month and [Enter] to go to next screen for year**
- **IF NECESSARY**: What would be your best estimate?
- **If R says more than one foreclosure**: Please tell us about the first of those foreclosures

1. January	2. February	3. March	4. April	5. May	6. June
7. July	8. August	9. September	10. October	11. November	12. December
21. Winter	22. Spring	23. Summer	24. Fall		

A37C. (In what month and year did the foreclosure start?)

[A37B], _____

- **ENTER Year**: [[P2YEAR] / [P4YEAR] / 2001] – [CYEAR]
- **If R says more than one foreclosure**: Please tell us about the first of those foreclosures

REINT, RECLONG [P2YEAR] – [CYEAR]

RECON [P4YEAR] – [CYEAR]

ALL OTHERS 2001 – [CYEAR]

A37D. Was the home foreclosed upon?

- **If R says more than one foreclosure**: Please tell us about the first of those foreclosures

1. Yes 5. No → GO TO A37F



A37E. Did you lose your home as a result of this foreclosure?

- **If R says more than one foreclosure**: Please tell us about the first of those foreclosures

1. Yes 5. No

A37F. Was this home your main residence, investment property, a vacation home or what?

- **If R says more than one foreclosure**: Please tell us about the first of those foreclosures

1. Main residence	2. Investment property	3. Vacation home / condo
7. Other-specify (A37FSPEC. Please specify. (String 255))		

A37G. About how much did you still owe on your mortgage or loan when the foreclosure started?

- If R says more than one foreclosure: Please tell us about the first of those foreclosures

END A37FOR

Utilities

A42. The next few questions are about your utilities for your [apartment / mobile home / home].

Do you [and your family living there] get one bill that combines electricity, gas, and other fuel for your home?

- If R says Yes, PROBE: Would you be able to separate those amounts?
- ENTER [5] for “does not use gas”, “utilities included in rent”

1. Yes, one bill and R can report separate amounts	2. Yes, one bill but R cannot report separate amounts	5. No, not on one bill	DK/RF
↓	GO TO A42C	↓	

A42A. How much do you [and your family living there] usually pay for gas or other types of fuel (for your [apartment / mobile home / home]) per month on average?

- [HU/CS IN FU: Remind R not to include amounts paid by HU or HUCS people]
- ENTER amount here, then SELECT unit of time on next screen (Month, Year)

→ GO TO A42B → GO TO A42B



A42APER. The amount entered is: [A42A] per ____

- SELECT the unit of time below

A42B. (How much do you [and your family living there] usually pay...)

For electricity per month?

- [HU/CS IN FU: Remind R not to include amounts paid by HU or HUCS people]
- ENTER amount here, then SELECT unit of time on next screen (Month, Year)

→ GO TO A43CKPT → GO TO A43CKPT



A42BPER. The amount entered is: [A42B] per ____

- SELECT the unit of time below

GO TO A43CKPT

A42C. How much do you [and your family living there] usually pay for these (electricity and gas or other types of fuel) combined?

- [HU/CS IN FU: Remind R not to include amounts paid by HU or HUCS people]
- ENTER amount here, then SELECT unit of time on next screen (Month, Year)

→ GO TO A43CKPT → GO TO A43CKPT



A42CPER. The amount entered is: [A42C] per ____

- SELECT the unit of time below

A43CKPT. CAI Checkpoint: Whether Sewer/Water Included In Mobile Home Rent

1. Not Included; Not Mobile Home (A4<>4 or (A4=4 & (A20H<>Yes & A31A<>Yes)))	5. Included (A4=4 & (A20H=Yes or A31A=Yes))	→ GO TO A44
↓		

A43. (How much do you [and your family living there] usually pay...)

For water and sewer per month?

- [HU/CS IN FU: Remind R not to include amounts paid by HU or HUCS people]
- ENTER amount here, then SELECT unit of time on next screen (Quarter, Month, Year)

 → GO TO A44 → GO TO A44

A43PER. The amount entered is: [A43] per ____

- SELECT the unit of time below

A44. (How much do you [and your family living there] usually pay...)

For telephone, including cell phone, cable or satellite TV, and internet service combined, per month?

- Includes streaming services such as Hulu and Netflix
- [HU/CS IN FU: Remind R not to include amounts paid by HU or HUCS people]
- ENTER amount here, then SELECT unit of time on next screen (Month, Year)

 → GO TO A45 → GO TO A45

A44PER. The amount entered is: [A44] per ____

- SELECT the unit of time below

A45. And do you have any other utility expenses?

 → GO TO A40

A45A. What are those other utility expenses?

A45B. On average, how much are these other utility expenses per month?

- [HU/CS IN FU: Remind R not to include amounts paid by HU or HUCS people]
- ENTER amount here, then SELECT unit of time on next screen (Month, Year)

 → GO TO A40

A45BPER. The amount entered is: [A45B] per ____

- SELECT the unit of time below

A40. How is your [apartment / mobile home / home] heated - with gas, electricity, oil or what?

- ENTER all that apply
- PROBE: Any others?

1. Gas	2. Electricity	3. Oil	4. Wood	5. Coal	6. Solar	10. Bottled gas; propane	11. Kerosene
97. Other-specify (A40SPEC. Please specify. (String 100))							

A46. There are government programs that give money to people to help them pay for heating and cooling their homes. Did you receive help from such a program last year ([PYEAR])?

1. Yes	5. No	→ GO TO A57CKPT
--------	-------	-----------------



A46A. About how much did that amount to altogether?

- If R gives a percentage, PROBE: Could you convert that into an amount? If YES, ENTER amount; If NO, PRESS [Enter] to record percentage
- ENTER dollar amount here, then SELECT unit of time on next screen (Month, Year) OR PRESS [Enter] to enter percentage

[ENTER]	→ GO TO A46PCT	\$ 1 – 9,997	DK/RF	→ GO TO A57CKPT
---------	----------------	--------------	-------	-----------------



A46APER. The amount entered is: [A46A] per ____

- SELECT the unit of time below

5. Month	6. Year	7. Other-specify (A46APERSPEC. Please specify. (String 100))
----------	---------	--

GO TO A57CKPT

A46PCT. (What percent did that amount to altogether?)

- ENTER a percentage from 1.0 to 100.0

1.0 – 100.0 %

A57CKPT. CAI Checkpoint: Who is Respondent

1. R=Proxy (RESPONDENT=7)	5. R= Reference Person, Spouse/Partner, OFUM (RESPONDENT=1-4)
GO TO SECTION BC	

↓

Device and Internet Use - Reference Person and Spouse/Partner

SECTION_A.A57 [1-2] [1]=Current Reference Person, [2]=Current Spouse/Partner

AQSN. AQSN of Current Reference Person (Spouse/Partner)

A57A. [CYNAMF CYNAML], [CYAQRTH, [CYFUHU], AGE [AGEIWDATE] [(Respondent)]

[Do you / Does [RP / SP]] have a computer, laptop, or tablet that [you / he / she] can use at home?

- If needed: Include devices that [you / he / she] might bring home to do work related to [your / his / her] job.
- If needed: A tablet is used by touching the screen, like the iPad, Samsung Galaxy, Motorola Xoom, or Kindle Fire.

1. Yes	5. No	→ GO TO A57D
--------	-------	--------------



A57B. [CYNAMF CYNAML], [CYAQRTH, [CYFUHU], AGE [AGEIWDATE] [(Respondent)]

In the past month, how often [have you / has [he / she]] gone on the Internet using a computer, laptop, or tablet at home?

Would you say every day, a few times a week, once a week, less than once a week, or never?

1. Every day 2. A few times a week 3. Once a week 4. Less than once a week 5. Never DK/RF

GO TO A57E



A57C. [CYNAMF CYNAML], [CYAQRTH, [CYFUHU], AGE [AGEIWDATE] [(Respondent)]

In the past year, [have you / has [he / she]] gone on the Internet using a computer, laptop, or tablet at home?

1. Yes → GO TO A57E 5. No



A57D. [CYNAMF CYNAML], [CYAQRTH, [CYFUHU], AGE [AGEIWDATE] [(Respondent)]

In the past year, [have you / has [he / she]] gone on the Internet using a computer, laptop, or tablet somewhere other than [your / his / her] home?

1. Yes 5. No

A57E. [CYNAMF CYNAML], [CYAQRTH, [CYFUHU], AGE [AGEIWDATE] [(Respondent)]

[Do you / Does [RP / SP]] have a smart phone that [you / he / she] can use to go on the Internet?

1. Yes 5. No → GO TO A57J



A57F. [CYNAMF CYNAML], [CYAQRTH, [CYFUHU], AGE [AGEIWDATE] [(Respondent)]

In the past month, how often [have you / has [he / she]] sent or received text messages on [your / his / her] smart phone?

Would you say every day, a few times a week, once a week, less than once a week, or never?

1. Every day 2. A few times a week 3. Once a week 4. Less than once a week 5. Never

A57G. [CYNAMF CYNAML], [CYAQRTH, [CYFUHU], AGE [AGEIWDATE] [(Respondent)]

In the past month, how often [have you / has [he / she]] used [your / his / her] smart phone to access email or other websites on the Internet?

(Would you say every day, a few times a week, once a week, less than once a week, or never?)

1. Every day 2. A few times a week 3. Once a week 4. Less than once a week 5. Never DK/RF

GO TO A57LCKPT



A57H. [CYNAMF CYNAML], [CYAQRTH, [CYFUHU], AGE [AGEIWDATE] [(Respondent)]

In the past year, [have you / has [he / she]] used [your / his / her] smart phone to access email or other websites on the Internet?

1. Yes 5. No

GO TO A57LCKPT

A57J. [CYNAMF CYNAML], [CYAQRTH, [CYFUHU], AGE [AGEIWDATE] [(Respondent)]

[Do you / Does [RP / SP]] have a cell phone?

1. Yes 5. No → GO TO A57LCKPT



A57K. [CYNAMF CYNAML], [CYAQRTH, [CYFUHU], AGE [AGEIWDATE] [(Respondent)]

In the past month, how often [have you / has [he / she]] sent or received text messages on [your / his / her] cell phone?

(Would you say every day, a few times a week, once a week, less than once a week, or never?)

1. Every day 2. A few times a week 3. Once a week 4. Less than once a week 5. Never

A57LCKPT. CAI Checkpoint: Whether Used Internet in Past Year

1. Has Not Used Internet (A57A=No, DK/RF or (A57C=No, DK/RF & A57D=No, DK/RF)) & (A57E=No, DK/RF or (A57G=Never, DK/RF & A57H=No, DK/RF))	→ GO TO A57 END RULE	5. All Others ↓
---	-------------------------	--------------------

A57L. [CYNAMF CYNAML], [CYAQRTH, [CYFUHU], AGE [AGEIWDATE] [(Respondent)]

In the past month, how often [have you / has [he / she]] used email?

(Would you say every day, a few times a week, once a week, less than once a week, or never?)

1. Every day 2. A few times a week 3. Once a week 4. Less than once a week 5. Never DK/RF

GO TO A57 END RULE



A57M. [CYNAMF CYNAML], [CYAQRTH, [CYFUHU], AGE [AGEIWDATE] [(RESPONDENT)]

In the past year, [have you / has [he / she]] used email?

1. Yes 5. No

A57 END Rule: Whether Spouse/Partner in FU

Spouse/Partner (CYAQRTH=201-222, CYFUHU=FU, FUMI)	→ Repeat A57; Then GO TO SECTION BC	No Spouse/Partner GO TO SECTION BC
---	--	---------------------------------------

END A57

END SECTION_A

Section BC: Employment

[TOC](#)

Employment Status - Reference Person and Spouse/Partner

EMPLOYEEHC 1[1-2] [1]=Current Reference Person, [2]=Current Spouse/Partner

BCDE1. [CYNAMF CYNAML]: [CYAQRTH], [CYFUHU], Age [AGEIWDATE] [(Respondent)]

We would like to know about what [you do / [RP / SP] does] - [are you / is [RP / SP]] working now, looking for work, retired, keeping house, a student, or what?

- If R says "Unemployed/Not working", PROBE: [Are you / Is [RP / SP]] looking for work?
 - If unemployed/not working and looking for work, ENTER [3]
 - If unemployed/not working and not looking for work, ENTER [6]
- ENTER all that apply
- PROBE: Anything else?

1. Working now	2. Only temporarily laid off, sick or maternity leave	3. Looking for work, unemployed	4. Retired
		5. Disabled, permanently or temporarily	↓
		6. Keeping house	7. Student
GO TO EHCINTRO		8. Other-specify (BCDE1SPEC. Please tell me what [you are / [RP / SP] is] doing now. (String 100))	BCDE2. In what year did [you / [RP / SP]] (last) retire?
		DK/RF	1901 – [CYEAR]

↓

BCDE3. [CYNAMF CYNAML]: [CYAQRTH], [CYFUHU], Age [AGEIWDATE] [(Respondent)]

[Are you / Is [he / she]] doing any work for money now?

1. Yes → GO TO EHCINTRO 5. No

↓

BCDE3A. [CYNAMF CYNAML]: [CYAQRTH], [CYFUHU], Age [AGEIWDATE] [(Respondent)]

[Have you / Has [RP / SP]] done any work for money since January 1, [P2YEAR]? Please include any type of work, no matter how small.

1. Yes 5. No

EHCINTRO. [CYNAMF CYNAML]: [CYAQRTH], [CYFUHU], Age [AGEIWDATE] [(Respondent)]

Next, I will be asking you about [BCDE1=WORKING, LAID OFF or BCDE3=WORKING NOW or BCDE3A=HAS WORKED: jobs [you / [RP / SP]] had / ALL OTHERS: what [you have / [RP / SP] has] done] and places [you have / [RP / SP] has] lived during the past two years.

- ENTER [1] to go into [CYNAMF CYNAML]'s employment EHC

1. Continue

EHC - Residences

LANDMARKRESIDENCESECTION.RESECTION [1-6] [1-6]=Which residence

Asked for RP only; If REINT & same RP as last wave & preload=Response, then timeline #1 is preloaded with last wave residence.

Residence Domain

[CYNAMF CYNAML]: [CYAQRTH], [CYFUHU], Age [AGEIWDATE] [(Respondent)] End date of calendar is [IWSTARTDATE]

[SP LOOP: IWER: Residence domain is disabled because this is the Spouse/Partner EHC]

1. [PRELOADED: IWER: Residence timeline #1 has been preloaded with [RP]'s [P2YEAR] residence. CLICK on address label (left-column) and PROBE whether this is still [his / her] current residence. VERIFY and EDIT Start Date and Address as needed. / ALL OTHERS: What is the street address and move-in date of [your / [RP]'s] current residence?]

2. [PRELOADED: If needed:] [Have you / Has [he / she]] lived anywhere else since January [P2YEAR]? IF YES: Please tell me the address of each of those residences and the dates [you / he / she] lived there.

PROBE for full address

If R says "Homeless", ENTER [Homeless] in the Address field for that timeline

IWER: By "Winter" we mean Dec, Jan and Feb in that order and overlapping 2 calendar years. If R says "Winter", PROBE whether that is late in the year (Dec) or early in the following year (Jan, Feb).

sADDRESS. sCITY. ISCURRENT. Current residence SAMERES. Pld residence is current (Reint)

sSTATE. sZIP.

sCOUNTRY.

SMONTHSEASON; EMONTHSEASON. Starting and Ending Month/Season

<input type="text" value="21. Winter"/>	<input type="text" value="12. December"/>	<input type="text" value="1. January"/>	<input type="text" value="2. February"/>	<input type="text" value="DK"/>
<input type="text" value="22. Spring"/>	<input type="text" value="3. March"/>	<input type="text" value="4. April"/>	<input type="text" value="5. May"/>	
<input type="text" value="23. Summer"/>	<input type="text" value="6. June"/>	<input type="text" value="7. July"/>	<input type="text" value="8. August"/>	
<input type="text" value="24. Fall"/>	<input type="text" value="9. September"/>	<input type="text" value="10. October"/>	<input type="text" value="11. November"/>	

SDAY; EDAY. Starting and Ending Day/3rd of Month

<input type="text" value="41. First third"/>	<input type="text" value="1"/>	<input type="text" value="2"/>	<input type="text" value="3"/>	<input type="text" value="4"/>	<input type="text" value="5"/>	<input type="text" value="6"/>	<input type="text" value="7"/>	<input type="text" value="8"/>	<input type="text" value="9"/>	<input type="text" value="10"/>	<input type="text" value="DK"/>
<input type="text" value="42. Middle third"/>	<input type="text" value="11"/>	<input type="text" value="12"/>	<input type="text" value="13"/>	<input type="text" value="14"/>	<input type="text" value="15"/>	<input type="text" value="16"/>	<input type="text" value="17"/>	<input type="text" value="18"/>	<input type="text" value="19"/>	<input type="text" value="20"/>	
<input type="text" value="43. Last third"/>	<input type="text" value="21"/>	<input type="text" value="22"/>	<input type="text" value="23"/>	<input type="text" value="24"/>	<input type="text" value="25"/>	<input type="text" value="26"/>	<input type="text" value="27"/>	<input type="text" value="28"/>	<input type="text" value="29"/>	<input type="text" value="30"/>	

SYEAR; EYEAR. Starting and Ending Year

Past Residences

A50. Why did [you / he / she] move?

If "Homeless", DO NOT READ question-SELECT [9]

ENTER all that apply

PROBE: Any other reasons?

<input type="text" value="1. Take a job; stopped school"/>	<input type="text" value="2. Nearer to work"/>
<input type="text" value="3. More space; better place"/>	<input type="text" value="4. Smaller; less expensive"/>
<input type="text" value="5. Get own home/place; got married"/>	
<input type="text" value="6. Better area; close to family"/>	
<input type="text" value="7. Evicted; divorced; job transfer; foreclosed"/>	
<input type="text" value="8. Other-specify (A50OTHER. Specify (String 200))"/>	
<input type="text" value="9. Homeless"/>	<input type="text" value="10. DK"/>
<input type="text" value="11. RF"/>	

Current Residence

A51. Do you think [you / he / she] might move in the next couple of years?

→ EXIT



A52. Would you say [you / he / she] definitely will move, probably will move, or are you more uncertain?

A53. Why [will/might] [you/ he / she] move?

For Don't Know type [DK]; For Refusal, type [RF]

END RESECTION

EHC - Employers

EMPLOYEHC1 [1-2].EMPLOYSECTION [1-10] [1]=Current RP, [2]=Current SP; [1-10]=Which employer
 Disabled if BCDE3=No, DK/RF & BCDE3A=No, DK/RF; If REINTERVIEW & same RP/SP as last wave & preloaded
 CMJ=Response, then timeline#1 preloaded with that CMJ.

Employment Domain

[CYNAMF CYNAML]: [CYAQRTH], [CYFUHU], Age [AGEIWDATE] [(Respondent)] End date of calendar is [IWSTARTDATE]
 I'd like to know about all of the work for money that [you have / [RP / SP has]] done since January 1, [P2YEAR]. Please
 include self-employment and any other kind of work that [you have / [he / she] has] done for pay. [PRELOADED CMJ: IWER:
 Employment timeline #1 has been preloaded with [RP / SP]'s [P2YEAR] current main job. CLICK on employer name (left-
 column) and PROBE whether this is still a current job. VERIFY and EDIT Start Date and Employer as needed. / ALL OTHERS:
 Start with any job that [you / [RP / SP]] had during this time.]

1. [PRELOADED CMJ: If needed:] What (is / was) the name of this employer?
2. [PRELOADED CMJ: If needed:] When did [you / [RP / SP]] start and when did [you / he / she] stop working for this employer? Please give me all of [your / his / her] start and stop dates if [you have / [he / she] has] worked for (yourself / himself / herself / this employer) more than once.

Before exiting this domain, probe for any other work for pay, no matter how small.

IF NECESSARY: This information will help us to process employment information you gave us. The name itself will never be released as part of data from the study.

If no employer name is given by R, ask for job title or anything that can help identify the job.

By "Winter" we mean Dec, Jan and Feb in that order and overlapping 2 calendar years. If R says "Winter", PROBE whether that is late in the year (Dec) or early in the following year (Jan, Feb).

AQSN. AQSN of Current Reference Person (Spouse/Partner)

EMPLOYER. Name of employer ISCURRENT. Whether job is current

String 100	DK/RF	0. Not checked
		1. Checked

SMONTHSEASON; EMONTHSEASON. Starting and Ending Month/Season

21. Winter	12. December	1. January	2. February	DK
22. Spring	3. March	4. April	5. May	
23. Summer	6. June	7. July	8. August	
24. Fall	9. September	10. October	11. November	

SDAY; EDAY. Starting and Ending Day/3rd of Month

41. First third	1	2	3	4	5	6	7	8	9	10	DK
42. Middle third	11	12	13	14	15	16	17	18	19	20	
43. Last third	21	22	23	24	25	26	27	28	29	30	31

SYEAR; EYEAR. Starting and Ending Year

[P2YEAR]	[PYEAR]	[CYEAR]	1901– [P3YEAR]. Before [P2YEAR] → Enter Year 1901– [P3YEAR]
9997. DK (Before [P2YEAR])	9998. DK ([P2YEAR] – [CYEAR])		

END EMPLOYSECTION

EHC – Time Away from Work

EMPLOYEEHC1 [1-2].TIMEAWAYSECTION (2, 3, 4, 5) [1-5] [1]=Current RP, [2]=Current SP; [1-5]=Which time away; (2-5)=REASON; Disabled if BCDE3=No, DK/RF and BCDE3A=No, DK/RF.

Time Away Domain

[CYNAMF CYNAML]: [CYAQRTH], [CYFUHU], Age [AGEIWDATE] [(Respondent)]

1. While [you were / [RP / SP] was] employed during [PYEAR], did [you / he / she] miss any work because someone else was sick?
2. (Did [you / he / she] miss any work) because [you were / [he / she] was] sick?
3. (Did [you / he / she] miss any work) for a vacation or time off?
4. (Did [you / he / she] miss any work) because [you were / [he / she] was] on strike?
5. (Did [you / he / she] miss any work) because [you were / [he / she] was] temporarily laid off from work?

If Yes: When was that (or how much time was that) (in [PYEAR])?

PROBE each type of Time Away: Any others?

If R can remember dates, ENTER Start and End dates; Otherwise, CHECK “Don't Know When” box and ENTER duration of Months, Weeks, Days

By “Winter” we mean Dec, Jan and Feb in that order and overlapping 2 calendar years. If R says “Winter”, PROBE whether that is late in the year (Dec) or early in the following year (Jan, Feb).

AQSN. AQSN of Current Reference Person (Spouse/Partner)

REASON. Time Away Timelines per PYEAR

1. Someone else sick	2. Own sick	3. Vacation	4. On strike	5. Temporary layoff
----------------------	-------------	-------------	--------------	---------------------

MONTHSEASON; EMONTHSEASON. Starting and Ending Month/Season

21. Winter	12. December	1. January	2. February	DK
22. Spring	3. March	4. April	5. May	
23. Summer	6. June	7. July	8. August	
24. Fall	9. September	10. October	11. November	

SDAY; EDAY. Starting and Ending Day/3rd of Month

41. First third	1	2	3	4	5	6	7	8	9	10	DK
42. Middle third	11	12	13	14	15	16	17	18	19	20	
43. Last third	21	22	23	24	25	26	27	28	29	30	

SYEAR; EYEAR. Starting and Ending Year

[PYEAR]

TIME AWAY Rule

[DK When] Selected; or SMonth/EMonth=DK; or SMonth=EMonth & SDay/EDay=DK

↓

Don't Know When During PYEAR

DKWHENMONTHS.	0 – 12	DK
DKWHENWEEKS.	0 – 3	DK
DKWHENDAYS.	0 – 31	DK

END TIMEAWAYSECTION

EHC – Not Working

EMPLOYEEHC1 [1-2].NOTWORKSECTION (2, 3, 4) [1-5] [1]=Current RP, [2]Current SP; [1-5]=Which time away; (2-5)=LOOKNOT

Not Working Domain

[CYNAMF CYNAML]: [CYAQRTH], [CYFUHU], Age [AGEIWDATE] [(Respondent)]

1. Were there any times during [P2YEAR] when [you were / [RP / SP] was] not employed (not working at all for pay)? **IF YES:** [Were you / Was [he / she]] looking for a job, or not looking (for a job)?

PROBE: When was that (or how much time was that) (when [you were / [he / she] was] (looking / not looking) in [P2YEAR])?

2. Were there any times during [PYEAR] when [you were / [RP / SP] was] not employed (not working at all for pay)? **IF YES:** [Were you / Was [he / she]] looking for a job, or not looking (for a job)?

PROBE: When was that (or how much time was that) (when [you were / [he / she] was] (looking / not looking) in [PYEAR])?

If R can remember dates, ENTER Start and End dates; Otherwise, CHECK “Don't Know When” box and ENTER duration of Months, Weeks, Days

If R says the entire year, CHECK “Entire Year” box

By “Winter” we mean Dec, Jan and Feb in that order and overlapping 2 calendar years. If R says “Winter”, PROBE whether that is late in the year (Dec) or early in the following year (Jan, Feb).

AQSN. AQSN of Current Reference Person (Spouse/Partner)

LOOKNOT. Not Working Timelines per P2YEAR/PYEAR

ENTIREYR. Whether not working entire year

1. Looking 2. Not looking

0. Not checked 1. Checked

SMONTHSEASON; EMONTHSEASON. Starting and Ending Month/Season

21. Winter	12. December	1. January	2. February	DK
22. Spring	3. March	4. April	5. May	
23. Summer	6. June	7. July	8. August	
24. Fall	9. September	10. October	11. November	

SDAY; EDAY. Starting and Ending Day/3rd of Month

41. First third	1	2	3	4	5	6	7	8	9	10	DK
42. Middle third	11	12	13	14	15	16	17	18	19	20	
43. Last third	21	22	23	24	25	26	27	28	29	30	

SYEAR; EYEAR. Starting and Ending Year

NOT WORKING Rule

[DK When] Selected; or SMonth/EMonth=DK; or SMonth=EMonth & SDay/EDay=DK

↓

Don't Know When During [PYEAR/P2YEAR] [Looking / Not Looking]

DKWHENMONTHS.

DKWHENWEEKS.

DKWHENDAYS.

END NOTWORKSECTION

Confirm Same CMJ as Last Wave

CONFIRMSAMECMJ Rule: Whether Edits Made in EHC to Preloaded CMJ Name or Preloaded CMJ Start Date

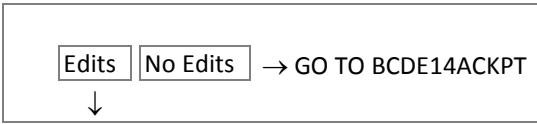

CONFIRMSAMECMJ. [CYNAMF CYNAML]: [CYAQRTH], [CYFUHU], Age [AGEIWDATE] [(Respondent)]
[\[EHC CMJ\] \(\[EHC MO/DY/YR\]\)](#)

Interviewer checkpoint:

You made changes to the preloaded current main job (CMJ) in the EHC:

CMJ preloaded from last wave: [PRELOAD CMJ] ([PRELOAD CMJ MO/DY/YR])

CMJ with edits this wave: [EHC CMJ] ([EHC MO/DY/YR])

Is the CMJ for this wave the same job as the CMJ that was preloaded from last wave?

ASK R if needed

- | | |
|-------------------------------|--------------------------------|
| 1. Yes, same job as last wave | 5. No, different job this wave |
|-------------------------------|--------------------------------|

PYear Weeks Worked and Hours per Week Worked

BCDE14ACKPT. CAI Checkpoint: Whether Had Job in PYEAR

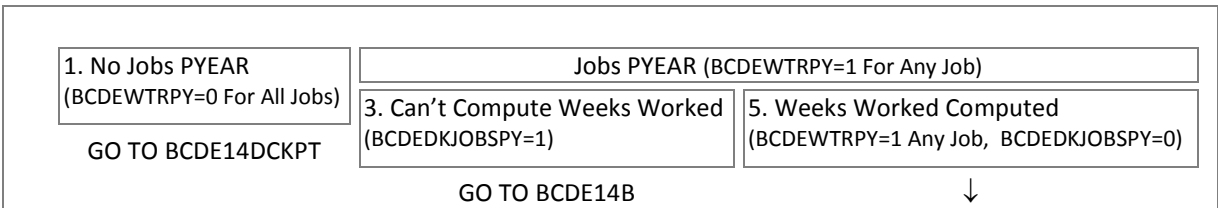

BCDE14A. [CYNAMF CYNAML]: [CYAQRTH], [CYFUHU], Age [AGEIWDATE] [(Respondent)]

EMPLOYMENT SUMMARY

[\[List of PYEAR Employers from EHC\]](#)

From the information you have given me on [2 JOBS: both of / >2 JOBS: all of] [your / [RP / SP]'s] [1 JOB: job / 2+ JOBS: jobs], [you were / [he / she] was] employed approximately [#WEEKS] out of 52 weeks in [PYEAR]. Does this sound correct?

- | | |
|-------------------------|-------|
| 1. Yes → GO TO BCDE14BB | 5. No |
|-------------------------|-------|



BCDE14B. [CYNAMF CYNAML]: [CYAQRTH], [CYFUHU], Age [AGEIWDATE] [(Respondent)]

EMPLOYMENT SUMMARY

[\[List of PYEAR Employers from EHC\]](#)

Thinking about [your / [RP / SP]'s] work in [PYEAR], how many weeks did [you / he / she] actually work on [all of] [your / his / her] [job / jobs] in [PYEAR], not counting time off for vacations, sick time, unemployment, etc.?

- | | | |
|-------------------|--------|-------|
| 0 → GO TO BCDE14C | 1 - 52 | DK/RF |
|-------------------|--------|-------|



BCDE14BB. [CYNAMF CYNAML]: [CYAQRTH], [CYFUHU], Age [AGEIWDATE] [(Respondent)]

EMPLOYMENT SUMMARY

[List of PYEAR Employers from EHC]

On average, how many hours a week did [you / he / she] work on [all of] [your / his / her] [job / jobs] during [PYEAR]?

- ROUND DOWN for fractions less than ½ (0.5)
- ROUND UP for fractions ½ (0.5) or more

1 – 112 DK/RF → GO TO BCDE14DCKPT



BCDE4B3. [CYNAMF CYNAML]: [CYAQRTH], [CYFUHU], Age [AGEIWDATE] [(Respondent)]

EMPLOYMENT SUMMARY

[List of PYEAR Employers from EHC]

Did [you / he / she] work any overtime which isn't included in that?

1. Yes 5. No → GO TO BCDE14DCKPT



BCDE14B4. [CYNAMF CYNAML]: [CYAQRTH], [CYFUHU], Age [AGEIWDATE] [(Respondent)]

EMPLOYMENT SUMMARY

[List of PYEAR Employers from EHC]

How many hours did that overtime amount to (on [all of] [your / his / her] [job / jobs] in [PYEAR])?

- ENTER amount here, then SELECT unit of time on next screen (Week, Two weeks, Month, Year)
- ROUND DOWN for fractions less than ½ (0.5)
- ROUND UP for fractions ½ (0.5) or more

1 – 3760 DK/RF → GO TO BCDE14DCKPT



BCDE14B4PER. The amount entered is: [BCDE14B4] per ____

- SELECT the unit of time below

3. Week 4. Two weeks 5. Month 6. Year

7. Other-specify (BCDE14B4PERSPEC. Please specify. (String 100))

GO TO BCDE14DCKPT

BCDE14C. [CYNAMF CYNAML]: [CYAQRTH], [CYFUHU], Age [AGEIWDATE] [(Respondent)]

IWER: The EHC indicates that [RP / SP] had a job in [PYEAR], but BCDE14B is '00' for total weeks worked in [PYEAR]. Please explain why.

EMPLOYMENT SUMMARY

[List of PYEAR Employers from EHC]

String 500

BCDE14DCKPT. CAI Checkpoint: Whether Had Job inP2YEAR

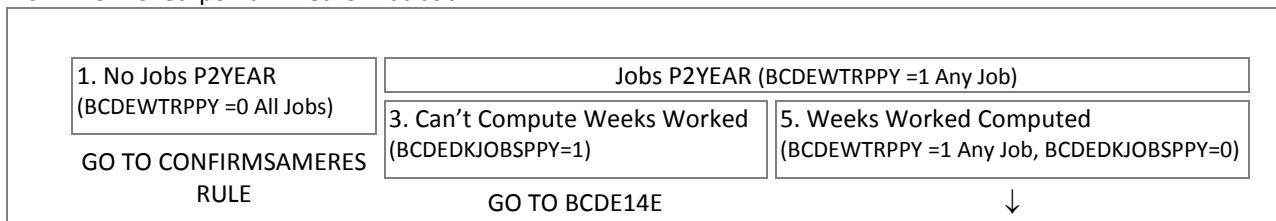

P2Year Weeks Worked and Hours per Week Worked

BCDE14D. [CYNAMF CYNAML]: [CYAQRTH], [CYFUHU], Age [AGEIWDATE] [(Respondent)]

EMPLOYMENT SUMMARY

[List of P2YEAR Employers from EHC]

For the year before last, [P2YEAR], from the information you have given me on [both of / all of] [your / your / [RP / SP]'s] [job / jobs], [you were / [he / she] was] employed approximately [#WEEKS] out of 52 weeks in [P2YEAR].

Does this sound correct?

1. Yes → GO TO BCDE14EE 5. No



BCDE14E. [CYNAMF CYNAML]: [CYAQRTH], [CYFUHU], Age [AGEIWDATE] [(Respondent)]

EMPLOYMENT SUMMARY

[List of P2YEAR Employers from EHC]

Thinking about [your / your / [RP / SP]'s] work in [P2YEAR], how many weeks did [you / he / she] actually work on [all of] [your / his / her] [job / jobs] in [P2YEAR], not counting time off for vacations, sick time, unemployment, etc.?

→ GO TO BCDE14F



BCDE14EE. [CYNAMF CYNAML]: [CYAQRTH], [CYFUHU], Age [AGEIWDATE] [(Respondent)]

EMPLOYMENT SUMMARY

[List of P2YEAR Employers from EHC]

On average, how many hours a week did [you / he / she] work on [all of] [your / his / her] [job / jobs] during [P2YEAR]?

- ROUND DOWN for fractions less than ½ (0.5)
- ROUND UP for fractions ½ (0.5) or more

GO TO SAME RESIDENCE RULE

BCDE14F. [CYNAMF CYNAML]: [CYAQRTH], [CYFUHU], Age [AGEIWDATE] [(Respondent)]

IWER: The EHC indicates that [RP / SP] had a job in [P2YEAR], but BCDE14E is '00' for total weeks worked in [P2YEAR]. Please explain why.

EMPLOYMENT SUMMARY

[List of P2YEAR Employers from EHC]

CONFIRMSAMERES Rule: Whether Edits Made in EHC to Preloaded Residence or Preloaded Start Date

<input type="text" value="Edits"/> <input type="text" value="No Edits"/> → GO TO BC15CKPT
↓

Confirm Same Residence as Last Wave

CONFIRMSAMERES. [CYNAMF CYNAML]: [CYAQRTH], [CYFUHU], Age [AGEIWDATE] [(Respondent)]

Interviewer checkpoint:

You made changes to the preloaded residence in the EHC:

Residence preloaded from last wave: [PRELOAD RES CITY, STATE, ZIP] ([PRELOAD RES MO/DY/YR])

Residence with edits this wave: [EHC RES] ([EHC MO/DY/YR])

Is the address for this wave the same residence as the address that was preloaded from last wave?

ASK R if needed

1. Yes, same residence as last wave	5. No, different residence this wave
-------------------------------------	--------------------------------------

END EMPLOYEHC1

SECTION_BC [1-2] [1]=Current Reference Person, [2]=Current Spouse/Partner

EMPLOYMENT INDICATORS	
BCWTRWRK	0, 1: Whether working now or worked since 1/1/P2YEAR
BCJOBACOUNT	0 - 10: Total jobs since 1/1/P2YEAR
BCCURCOUNT	0 - 10: Total current jobs
BCMOSTRECCOUNT	0 - 10: Total recent jobs
PER JOB INDICATORS	
BC18.JOBNUM	1 - 10
BC18.EMPNAME	Employer name
BC18.JOBTYP	1=CMJ, 2=MRMJ, 3=Other job
BC18.SAMECMJPRELOAD	1=CMJ, same as last wave, 5=All others (CMJ, not same as last wave; MRMJ; Other job)
BCJOBINFO.BCWTRP2YEAR	0, 1: Whether worked at this job in P2YEAR
BCJOBINFO.BCWTRP1YEAR	0, 1: Whether worked at this job in PYEAR
BCJOBINFO.BCWTRCYR	0, 1: Whether worked at this job in CYEAR
BCJOBINFO.BCCUR	0, 1: Whether job is current
BCJOBINFO.BCMOSTREC	0, 1: Whether job is recent

BC15CKPT. CAI Checkpoint: Number and Types of Job

Employers Exported From EHC (BCWTRWRK=1)				5. All Others
1. One Current Job	2. 2+ Current Jobs	3. One Most Recent Job	4. 2+ Most Recent Jobs	GO TO BC60ACKPT
GO TO BC19CKPT	↓	GO TO BC19CKPT	↓	

BCAQSN. AQSN of Current Reference Person (Spouse/Partner)

Select CMJ or MRMJ

BC16. [CYNAMF CYNAML]: [CYAQRTH], [CYFUHU], Age [AGEIWDATE] [(Respondent)]

You have just told me that [you are / [RP / SP] is] working now for more than one employer. Which one of these jobs do you consider to be [your / his / her] main job?

- READ list of employers/jobs if needed

1 – 10. [EMPNAME] *List of current employers*

DK/RF NOT ALLOWED

ASSIGN BC18.JOBTYP=CMJ FOR SELECTED JOB

BC17. [CYNAMF CYNAML]: [CYAQRTH], [CYFUHU], Age [AGEIWDATE] [(Respondent)]

You mentioned [#] jobs that ended at the same time. Which one of these jobs do you consider to have been [your / his / her] main job?

- READ list of employers/jobs if needed

1 – 10. [EMPNAME] *List of non-current employers*

DK/RF NOT ALLOWED

ASSIGN BC18.JOBTYP=MRMJ FOR SELECTED JOB

Individual Job Information

SECTION_BC [1-2].BCJOBS [1-10] [1]=Current Reference Person, [2]=Current Spouse/Partner; [1-10]=Which employer

BC19CKPT. CAI Checkpoint: Whether Worked This Job in PYEAR–CYEAR

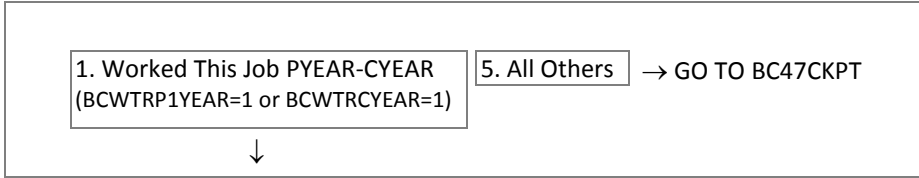

BC19BCKPT. CAI Checkpoint: Type of Interview (IWTYPE); Whether Same CMJ as Last Wave (BC18.SAMECMJPRELOAD)

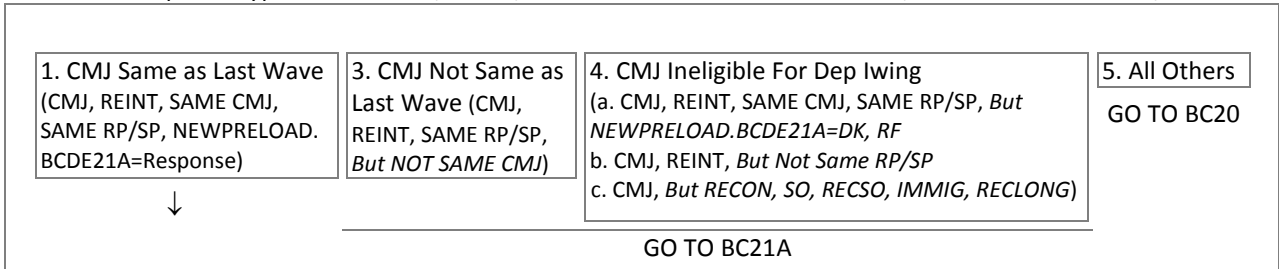

CMJ

Reinterview-dependent interviewing: Same CMJ
 All Other IW Types: n/a

BC19B. [CYNAMF CYNAML]: [CYAQRTH], [CYFUHU], Age [AGEIWDATE] [(Respondent)]

EMPLOYER: [EMPNAME] [(BEGMO/BEGYR) – [ENDMO/ENDYR]]

At our last interview [PYIWDATE=RESPONSE: on [PYIWDATE] / ALL OTHERS: in [P2YEAR]], we recorded [your / [RP / SP]'s] job title at [EMPNAME] [(BEGMO/BEGYR) – [ENDMO/ENDYR]] as [PRELOAD BCDE21A].

Is this [your / his / her] current job title?

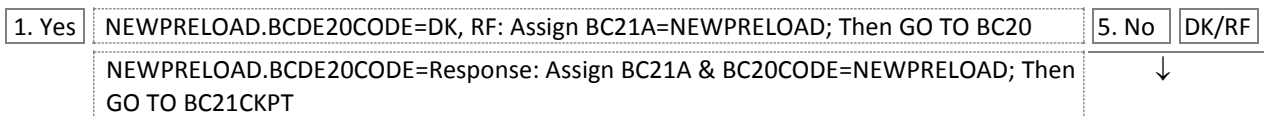

CMJ

Reinterview-dependent interviewing: Same CMJ & BC19B=No, DK/RF, or Not Same CMJ, or CMJ But INEL
 All Other IW Types: CMJ

BC21A. [CYNAMF CYNAML]: [CYAQRTH], [CYFUHU], Age [AGEIWDATE] [(Respondent)]

EMPLOYER: [EMPNAME] [(BEGMO/BEGYR) – [ENDMO/ENDYR]]

What is the official title of [your / [RP / SP]'s] job? (The title that [your / his / her] employer uses.)

String 200

BC20 RULE: Whether Same CMJ as Last Wave (BC18.SAMECMJPRELOAD); Whether Same Job Title as Last Wave (BC19B)

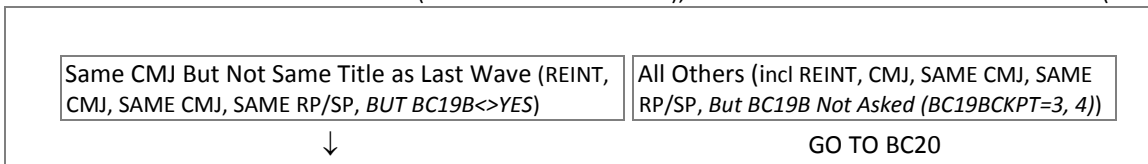

CMJ

Reinterview-dependent interviewing: Same CMJ & BC19B=No, DK/RF
 All Other IW Types: n/a

BC20CKPT. [CYNAMF CYNAML]: [CYAQRTH], [CYFUHU], Age [AGEIWDTE] [(Respondent)]

EMPLOYER: [EMPNAME] ([BEGMO/BEGYR] – [ENDMO/ENDYR])

Interviewer Checkpoint: You entered that [RP / SP]'s job title for this job has changed from [PRELOAD BCDE21A] to [BC21A]. Did R mention that the sort of work [RP / SP] does - job duties and activities - are the same even though the job title has changed?

ASK R if needed: Are your duties and activities on your job with [EMPNAME] the same even though your job title has changed?

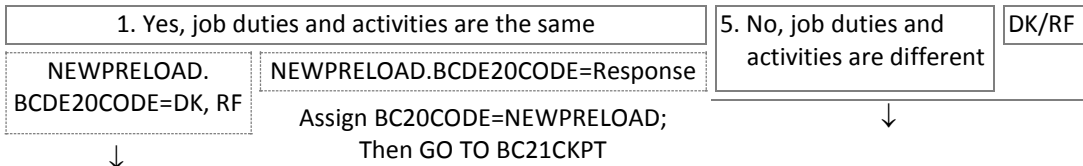

ALL JOBS PY-CY

Reinterview-dependent interviewing: Same CMJ & Title Not Same, or CMJ Not Same, or CMJ But INEL, or PY-CY MRMJ/OTHER JOB
 All Other IW Types: CMJ, or PY-CY MRMJ/OTHER JOB

BC20. [CYNAMF CYNAML]: [CYAQRTH], [CYFUHU], Age [AGEIWDTE] [(Respondent)]

EMPLOYER: [EMPNAME] ([BEGMO/BEGYR] – [ENDMO/ENDYR])

((And) the job with [EMPNAME] ([BEGMO/BEGYR] – [ENDMO/ENDYR]),...)

In [your / his / her] work for [EMPNAME] ([BEGMO/BEGYR] – [ENDMO/ENDYR]), [CMJ: what is [your / [RP / SP]'s] occupation? What sort of work [do you / does [he / she]] do? What are [your / his / her] most important activities or duties? / MRMJ: what was [your / [RP / SP]'s] occupation? What sort of work did [you / he / she] do? What were [your / his / her] most important activities or duties? / OTHER JOB: what sort of work [do you do / does [he / she] do] / did [you / he / she] do]?)

- [CMJ, MRMJ: PROBE up to 3 times if needed]
- [MRMJ: If needed, PROBE for most recent occupation at this employer]
- [OTHER JOB: DO NOT PROBE]
- To SAVE your entry, use Alt-S

Open End

BC21CKPT. CAI Checkpoint: Type of Interview (IWTYPE); Whether Same CMJ as Last Wave (BC18.SAMECMJPRELOAD)

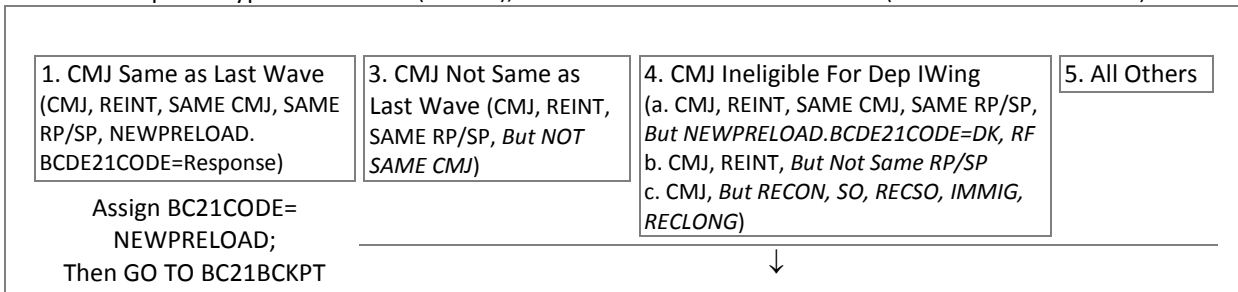

ALL JOBS PY-CY

Reinterview-dependent interviewing: CMJ Not Same, or CMJ But INEL, or PY-CY MRMJ/OTHER JOB
 All Other IW Types: CMJ, or PY-CY MRMJ/OTHER JOB

- BC21. [CYNAMF CYNAML]: [CYAQRTH], [CYFUHU], Age [AGEIWDATE] [(Respondent)]
 EMPLOYER: [EMPNAME] ([BEGMO/BEGYR] – [ENDMO/ENDYR])
 ((And) the job with [EMPNAME] ([BEGMO/BEGYR] – [ENDMO/ENDYR]),...)
 What kind of business or industry [is / was] that in?
- [JOBTYPE=OTHER: DO NOT PROBE]
 - To SAVE your entry, use Alt-S

Open End

NOTE: BC21A is found before BC20 RULE

BC21BCKPT. CAI Checkpoint: Job Type

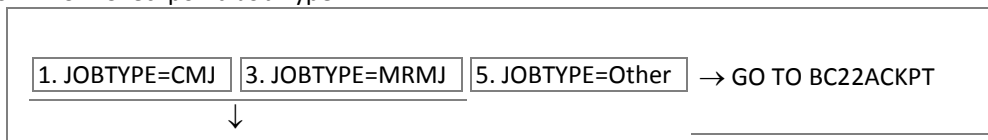

CMJ, or PY-CY MRMJ

- BC21B. [CYNAMF CYNAML]: [CYAQRTH], [CYFUHU], Age [AGEIWDATE] [(Respondent)]
 EMPLOYER: [EMPNAME] ([BEGMO/BEGYR] – [ENDMO/ENDYR])
 On a typical day, how many minutes [CMJ: is / MRMJ: was] [your / his / her] round trip commute to and from work?
- If R says “travels from home to temporary lodging near worksite”, ENTER [995]
 - If R says “it varies”, ENTER [996]
 - If R says “doesn’t commute” (e.g. self-employed, works from home), ENTER [997]

1 – 900 995. Temp lodging 996. It varies 997. No commute

BC22ACKPT. CAI Checkpoint: Type of Interview (IWTYPE); Whether Same CMJ as Last Wave (BC18.SAMECMJPRELOAD)

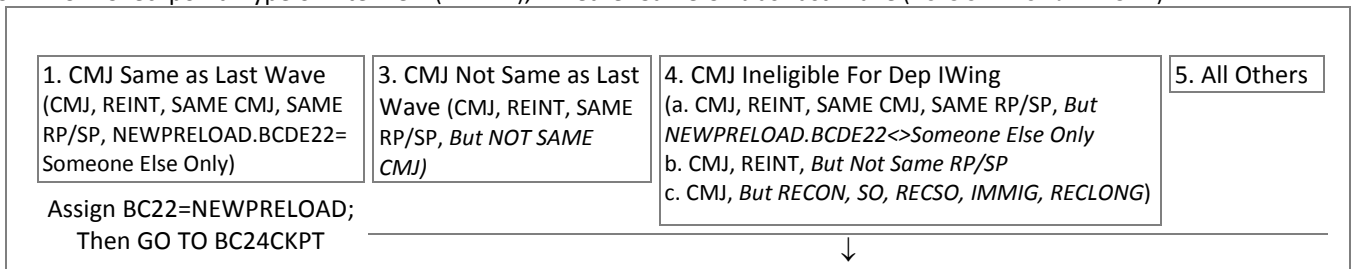
ALL JOBS PY-CY

Reinterview-dependent interviewing: CMJ Not Same, or CMJ But INEL, or PY-CY MRMJ/OTHER JOB
 All Other IW Types: CMJ, or PY-CY MRMJ/OTHER JOB

- BC22. [CYNAMF CYNAML]: [CYAQRTH], [CYFUHU], Age [AGEIWDATE] [(Respondent)]
 EMPLOYER: [EMPNAME] ([BEGMO/BEGYR] – [ENDMO/ENDYR])
 [[Are / Were] you] / [Is / Was] [RP / SP]] self-employed, [[are / were] you / [is / was] [he / she]] employed by someone else, or what?

1. Someone else only 2. Both someone else and self 3. Self-employed only DK/RF

GO TO BC24CKPT



GO TO BC25ACKPT

BC23. [CYNAMF CYNAML]: [CYAQRTH], [CYFUHU], Age [AGEIWDATE] [(Respondent)]
 EMPLOYER: [EMPNAME] ((BEGMO/BEGYR) – [ENDMO/ENDYR])
 [Is / Was] that an unincorporated business or a corporation?

1. Unincorporated 2. Corporation

GO TO BC25ACKPT

BC24CKPT. CAI Checkpoint: Type of Interview (IWTYPE); Whether Same CMJ as Last Wave (BC18.SAMECMJPRELOAD);
 Whether Works for Someone Else Only (NEWPRELOAD.BC22, BC22)

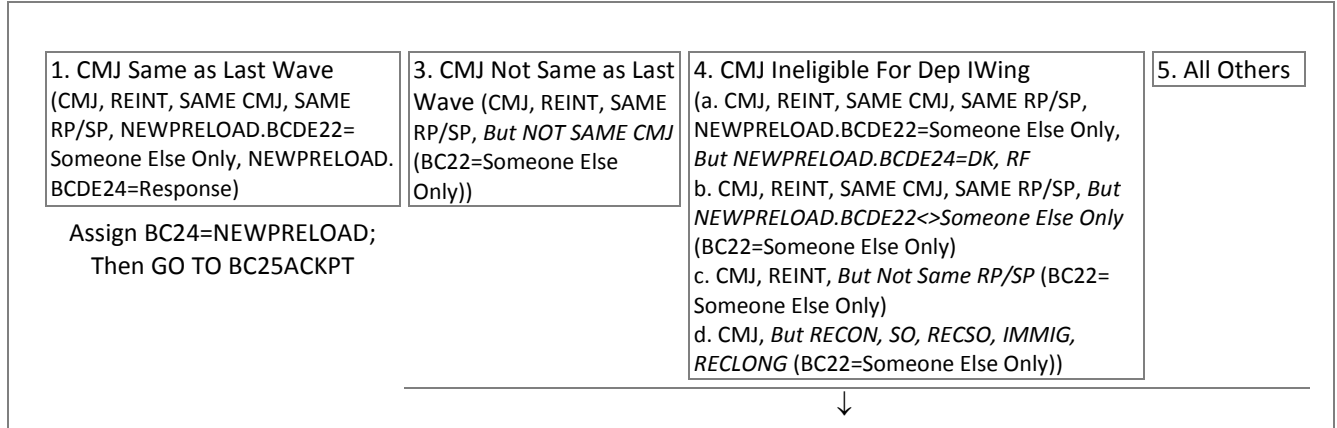

ALL JOBS PY-CY and BC22=Works for Someone Else Only

Reinterview-dependent interviewing: CMJ Not Same, or CMJ But INEL, or PY-CY MRMJ/OTHER JOB
All Other IW Types: CMJ, or PY-CY MRMJ/OTHER JOB

BC24. [Do you / Did [RP / SP]] work for the government or a private company?

- **IF R says government PROBE:** Is that the federal, state, or local government?

1. Federal government 2. State government 3. Local government 4. Private non-government
 7. **Other-specify** (BC24SPEC. **Specify.** (String 100))

BC25ACKPT. CAI Checkpoint: Type of Interview (IWTYPE); Whether Same CMJ as Last Wave (BC18.SAMECMJPRELOAD)

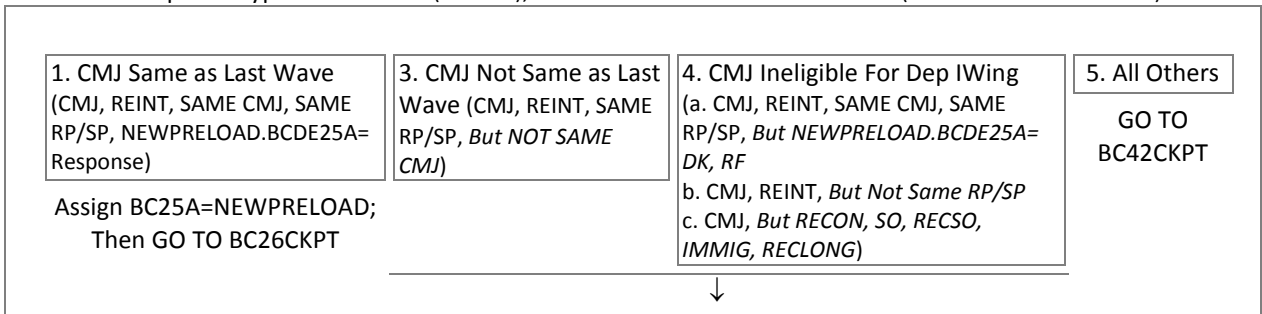

CMJ

Reinterview-dependent interviewing: CMJ Not Same, or CMJ But INEL
 All Other IW Types: CMJ

BC25A. [CYNAMF CYNAML]: [CYAQRTH], [CYFUHU], Age [AGEIWDATE] [(Respondent)]
 EMPLOYER: [EMPNAME] ([BEGMO/BEGYR] – [ENDMO/ENDYR])

Including [yourself / [RP / SP]], about how many people are employed [BC22=SOMEONE ELSE ONLY: (by [[EMPNAME] ([BEGMO/BEGYR] – [ENDMO/ENDYR])]] at the location where [you work / [RP / SP] works]?

1 – 999,999,997 → GO TO BC26CKPT DK/RF

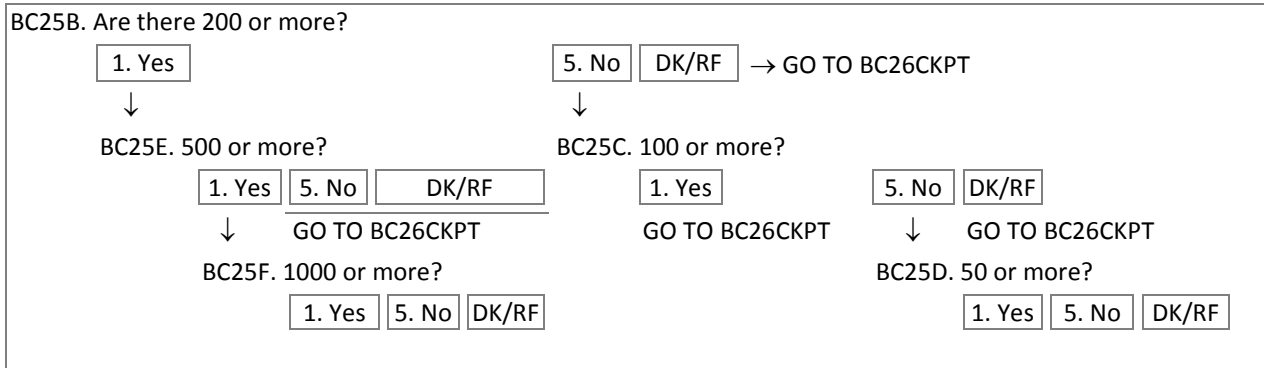

BC26CKPT. CAI Checkpoint: Type of Interview (IWTYPE); Whether Same CMJ as Last Wave (BC18.SAMECMJPRELOAD); Whether Same Job Title (BC19B); Whether Works for Someone Else Only

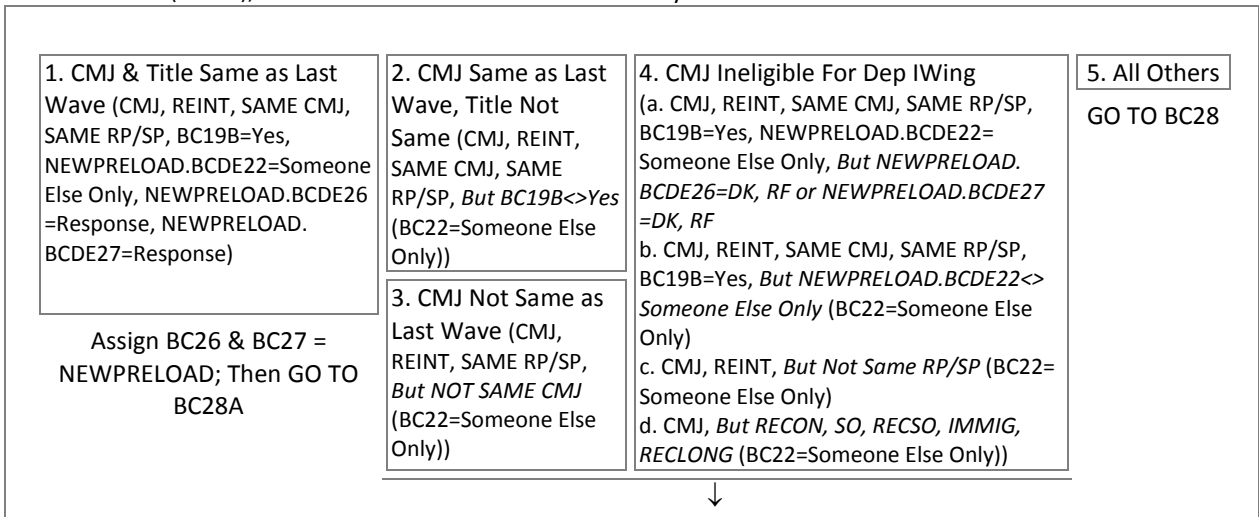

CMJ and BC22=Works for Someone Else Only

Reinterview-dependent interviewing: Same CMJ & Title Not Same, or CMJ Not Same, or CMJ But INEL
 All Other IW Types: CMJ

BC26. [CYNAMF CYNAML]: [CYAQRTH], [CYFUHU], Age [AGEIWDATE]
 EMPLOYER: [BC EMPNAME] ([BEGMO/BEGYR] – [ENDMO/ENDYR])

Is [your / his / her] current job covered by a union contract?

1. Yes 5. No → GO TO BC28A

↓

BC27. [CYNAMF CYNAML]: [CYAQRTH], [CYFUHU], Age [AGEIWDATE] [(Respondent)]
 EMPLOYER: [EMPNAME] ([BEGMO/BEGYR] – [ENDMO/ENDYR])
 [Do you / Does [RP / SP]] belong to that labor union?

1. Yes 5. No

GO TO BC28A

CMJ and BC22<>Works for Someone Else Only

BC28. [CYNAMF CYNAML]: [CYAQRTH], [CYFUHU], Age [AGEIWDATE] [(Respondent)]
 EMPLOYER: [EMPNAME] ([BEGMO/BEGYR] – [ENDMO/ENDYR])

Interviewer Checkpoint:

Is [RP / SP] a farmer or rancher?

- Ask R only if you are unclear about the answer.

1. Yes 5. No

CMJ

BC28A. [CYNAMF CYNAML]: [CYAQRTH], [CYFUHU], Age [AGEIWDATE] [(Respondent)]
 EMPLOYER: [EMPNAME] ([BEGMO/BEGYR] – [ENDMO/ENDYR])

And would you say [your / his / her] work requires the use of a computer - All of the time, Most of the time, Some of the time, or None of the time?

1. All of the time 2. Most of the time 3. Some of the time 4. None of the time

CMJ

BC29. [CYNAMF CYNAML]: [CYAQRTH], [CYFUHU], Age [AGEIWDATE] [(Respondent)]
 EMPLOYER: [EMPNAME] ([BEGMO/BEGYR] – [ENDMO/ENDYR])

On [your / his / her] main job for [EMPNAME] ([BEGMO/BEGYR] – [ENDMO/ENDYR]), [are you / is [RP / SP]]
 salaried, paid by the hour, or what?

1. Salaried 2. Salary + commission 3. Paid by hour 4. Hourly + tips 7. Other DK/RF

GO TO BC30

6. Hourly + commission

↓

GO TO
BC39A

GO TO BC33

BC38. [CYNAMF CYNAML]: [CYAQRTH], [CYFUHU], Age [AGEIWDATE] [(Respondent)]
 EMPLOYER: [EMPNAME] ([BEGMO/BEGYR] – [ENDMO/ENDYR])

How is that?

<input type="checkbox"/> 1. Piecework, hourly + piecework/ production	<input type="checkbox"/> 2. Commission
<input type="checkbox"/> 5. Self-employed, farmer, "profits" - draw on account	<input type="checkbox"/> 6. By the job/day/mile
<input type="checkbox"/> 7. Other-specify (BC38SPEC. Specify (String 500))	

BC39. [CYNAMF CYNAML]: [CYAQRTH], [CYFUHU], Age [AGEIWDATE] [(Respondent)]
 EMPLOYER: [EMPNAME] ([BEGMO/BEGYR] – [ENDMO/ENDYR])

If [you / he / she] worked an extra hour, how much would [you / he / she] earn for that hour?

- PER hour

\$ 0.00 – 999,997.99 → GO TO BC39A

CMJ - Salaried or Salary + commission

BC30. [CYNAMF CYNAML]: [CYAQRTH], [CYFUHU], Age [AGEIWDATE] [(Respondent)]

EMPLOYER: [EMPNAME] ([BEGMO/BEGYR] – [ENDMO/ENDYR])

How much is [your / his / her] salary?

- ENTER amount here, then SELECT unit of time on next screen (Week, Two weeks, Month, Year)

 → GO TO BC31

BC30PER. [CYNAMF CYNAML]: [CYAQRTH], [CYFUHU], Age [AGEIWDATE] [(Respondent)]

EMPLOYER: [EMPNAME] ([BEGMO/BEGYR] – [ENDMO/ENDYR])

- The salary amount entered is: [BC30] per ____
- SELECT the unit of time below

CMJ - Salaried or Salary + commission

BC31. [CYNAMF CYNAML]: [CYAQRTH], [CYFUHU], Age [AGEIWDATE] [(Respondent)]

EMPLOYER: [EMPNAME] ([BEGMO/BEGYR] – [ENDMO/ENDYR])

If [you / he / she] were to work more hours per week than usual, would [you / he / she] get paid for those extra hours of work?

 → GO TO BC35CKPT

BC32. [CYNAMF CYNAML]: [CYAQRTH], [CYFUHU], Age [AGEIWDATE] [(Respondent)]

EMPLOYER: [EMPNAME] ([BEGMO/BEGYR] – [ENDMO/ENDYR])

About how much would [you / he / she] make per hour for those extra hours?

- If needed: Would that be time and a half, double time, straight time, comp time or an exact amount?

GO TO BC35CKPT



BC32A. [CYNAMF CYNAML]: [CYAQRTH], [CYFUHU], Age [AGEIWDATE] [(Respondent)]

EMPLOYER: [EMPNAME] ([BEGMO/BEGYR] – [ENDMO/ENDYR])

- SPECIFY amount
- ENTER amount here, then SELECT unit of time on next screen (Hour, Day, Week, Two weeks, Month, Year)

 → GO TO BC35CKPT

BC32APER. [CYNAMF CYNAML]: [CYAQRTH], [CYFUHU], Age [AGEIWDATE] [(Respondent)]

EMPLOYER: [EMPNAME] ([BEGMO/BEGYR] – [ENDMO/ENDYR])

- The amount entered is: [BC32A] per ____
- SELECT the unit of time below

GO TO BC35CKPT

CMJ - Hourly or Hourly + tips or Hourly + commission

BC33. [CYNAMF CYNAML]: [CYAQRTH], [CYFUHU], Age [AGEIWDATE] [(Respondent)]
 EMPLOYER: [EMPNAME] ([BEGMO/BEGYR] – [ENDMO/ENDYR])

What is [your / his / her] hourly wage rate for [your / his / her] regular work time?

- PER hour

\$ 1.00 – 997.99

CMJ - Hourly or Hourly + tips or Hourly + commission

BC34. [CYNAMF CYNAML]: [CYAQRTH], [CYFUHU], Age [AGEIWDATE] [(Respondent)]
 EMPLOYER: [EMPNAME] ([BEGMO/BEGYR] – [ENDMO/ENDYR])

What is [your / his / her] hourly wage rate for overtime?

- ENTER all that apply
- ENTER Refusal [Ctrl-R] for “does not work overtime”, “does not get overtime pay”
- If R says “Straight time”, PROBE: Do you mean [you are / [he / she] is] paid the same rate for overtime as for regular hours?
- If R says “Comp time” or “compensation time”, PROBE: Do you mean [you receive / [he / she] receives] additional time off instead of overtime pay?

1. Time and a half 2. Double time 3. Straight time 4. Comp time 5. Exact amount-specify
 7. Other-specify (BC34SPEC. Specify other overtime wage rate. (String 100))



GO TO BC35CKPT

BC34A. [CYNAMF CYNAML]: [CYAQRTH], [CYFUHU], Age [AGEIWDATE] [(Respondent)]
 EMPLOYER: [EMPNAME] ([BEGMO/BEGYR] – [ENDMO/ENDYR])

- SPECIFY overtime exact amount
- ENTER amount here, then SELECT unit of time on next screen (Hour, Day, Week, Two weeks, Month, Year)

\$ 1.00 – 9,999,997.99 DK/RF → GO TO BC35CKPT



BC34APER. [CYNAMF CYNAML]: [CYAQRTH], [CYFUHU], Age [AGEIWDATE] [(Respondent)]
 EMPLOYER: [EMPNAME] ([BEGMO/BEGYR] – [ENDMO/ENDYR])

- The amount entered is: [BC34A] per ____
- SELECT the unit of time below

1. Hour 2. Day 3. Week 4. Two Weeks 5. Month 6. Year
 7. Other-specify (BC34APERSPEC. Specify. (String 100))

CMJ - Tips and Commissions

BC35CKPT. CAI Checkpoint: Whether Receives Tips or Commissions

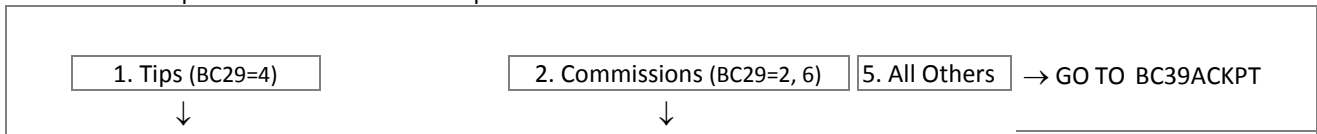

BC36. [CYNAMF CYNAML]: [CYAQRTH], [CYFUHU], Age [AGEIWDATE] [(Respondent)]
 EMPLOYER: [EMPNAME] [(BEGMO/BEGYR) – [ENDMO/ENDYR]]

How much are [your / his / her] tips, on average?

- ENTER amount here, then SELECT unit of time on next screen (Hour, Day, Week, Two weeks, Month, Year)

\$ 1.00 – 99,997.99 DK/RF → GO TO BC39ACKPT

↓

BC36PER. [CYNAMF CYNAML]: [CYAQRTH], [CYFUHU], Age [AGEIWDATE] [(Respondent)]
 EMPLOYER: [EMPNAME] [(BEGMO/BEGYR) – [ENDMO/ENDYR]]

The amount entered is: [BC36] per ____

- SELECT the unit of time below

1. Hour	2. Day	3. Week
4. Two Weeks	5. Month	6. Year
7. Other-specify (BC36PERSPEC. Specify. (String 100))		

BC37. [CYNAMF CYNAML]: [CYAQRTH], [CYFUHU], Age [AGEIWDATE] [(Respondent)]
 EMPLOYER: [EMPNAME] [(BEGMO/BEGYR) – [ENDMO/ENDYR]]

How much is [your / his / her] commission on average?

- ENTER amount here, then SELECT unit of time on next screen (Week, Two weeks, Month, Year)

\$ 1 – 9,999,997 DK/RF → GO TO BC39ACKPT

↓

BC37PER. [CYNAMF CYNAML]: [CYAQRTH], [CYFUHU], Age [AGEIWDATE] [(Respondent)]
 EMPLOYER: [EMPNAME] [(BEGMO/BEGYR) – [ENDMO/ENDYR]]

The amount entered is: [BC37] per ____

- SELECT the unit of time below

3. Week	4. Two Weeks	5. Month	6. Year
7. Other-specify (BC37ERSPEC. Specify. (String 100))			

BC39ACKPT. CAI Checkpoint: Number of Current Jobs

1. One Current Job (BCCUR=1 for just one job) → GO TO BC40CKPT	5. 2+ Current Jobs (BCCUR=1 for >1 job)
--	---

↓

CMJ - Hours Per Week Worked

BC39A. [CYNAMF CYNAML]: [CYAQRTH], [CYFUHU], Age [AGEIWDATE] [(Respondent)]
 EMPLOYER: [EMPNAME] [(BEGMO/BEGYR) – [ENDMO/ENDYR]]

On average, how many hours a week do you / does [RP / SP] currently work on this job?

- ROUND DOWN for fractions less than ½ (0.5)
- ROUND UP for fractions ½ (0.5) or more

1 – 112

BC40CKPT. CAI Checkpoint: Type of Interview (IWTYPE); Whether Same CMJ as Last Wave (BC18.SAMECMJPRELOAD); Whether Works for Someone Else Only (NEWPRELOAD.BC22, BC22)

1. CMJ Same as Last Wave (CMJ, REINT, SAME CMJ, SAME RP/SP, NEWPRELOAD.BCDE22=Someone Else Only, NEWPRELOAD.BCDE41=Response) Assign BC41=NEWPRELOAD + 2 YEARS; Then GO TO BC42CKPT	3. CMJ Not Same as Last Wave (CMJ, REINT, SAME RP/SP, But NOT SAME CMJ (BC22=Someone Else Only))	4. CMJ Ineligible For Dep IWing (a. CMJ, REINT, SAME CMJ, SAME RP/SP, NEWPRELOAD.BCDE22=Someone Else Only But NEWPRELOAD.BCDE41=DK, RF b. CMJ, REINT, SAME CMJ, SAME RP/SP, But NEWPRELOAD.BCDE22<>Someone Else Only (BC22=Someone Else Only) c. CMJ, REINT, But Not Same RP/SP (BC22=Someone Else Only) d. CMJ, But RECON, SO, RECSO, IMMIG, RECLONG (BC22=Someone Else Only))	5. All Others GO TO BC42CKPT
---	--	---	-------------------------------------

↓

CMJ and BC22=Works for Someone Else Only

Reinterview-dependent interviewing: CMJ Not Same, or CMJ But INEL

All Other IW Types: CMJ

BC41. [CYNAMF CYNAML]: [CYAQRTH], [CYFUHU], Age [AGEIWDATE] [(Respondent)]

EMPLOYER: [EMPNAME] [(BEGMO/BEGYR) – [ENDMO/ENDYR)]

How many years' experience [do you / does [RP / SP]] have altogether with [your / his / her] present employer?

- USE Years for amounts given in whole years
- USE Months and Weeks for amounts less than one year
- USE 1 week for amounts of one week or less

BC41.YEARS

BC41.MONTHS

BC41.WEEKS

BC42CKPT. CAI Checkpoint: Whether Worked Job in PYEAR; Whether PYEAR Weeks or Hours/Week Can Be Computed

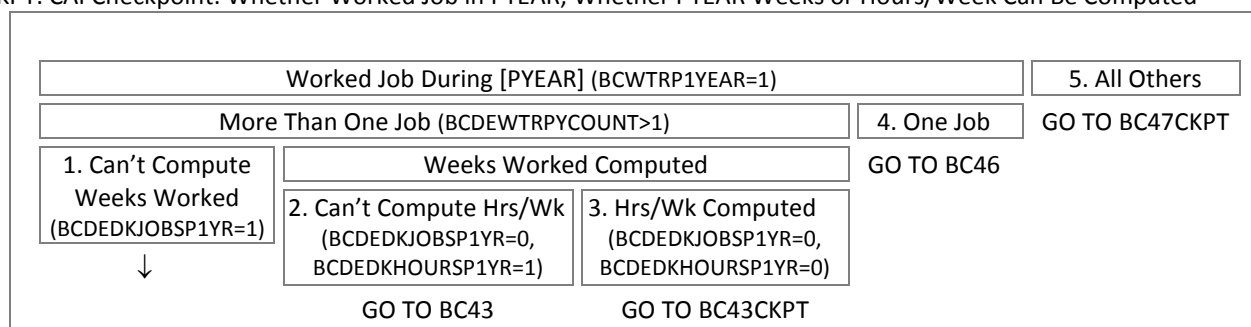

PYear Job and EmployEHC1.BCDEDKJobsP1Yr=1

BC42A. [CYNAMF CYNAML]: [CYAQRTH], [CYFUHU], Age [AGEIWDATE] [(Respondent)]

EMPLOYER: [EMPNAME] [(BEGMO/BEGYR) – [ENDMO/ENDYR)]

((And) the job with [EMPNAME] [(BEGMO/BEGYR) – [ENDMO/ENDYR)],...)

How many weeks out of the year did [you / [RP / SP]] actually work on this job in [PYEAR], not including any time off that you told me about earlier?

- IF R says "Every week except what (I / he / she) took off", ENTER [97]

*BC42A data used to calculate 'total weeks worked' and not included in public use data

BC43CKPT. CAI Checkpoint: Whether PYEAR Hours/Week Can Be Computed

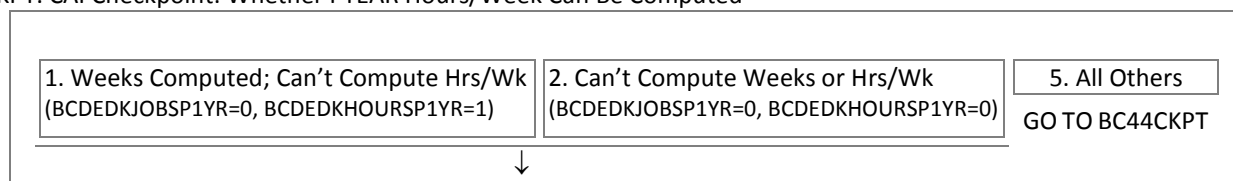

PYear Job and EmployEHC1.BCDEDkJobsP1Yr=1

- BC43. [CYNAMF CYNAML]: [CYAQRTH], [CYFUHU], Age [AGEIWDATE] [(Respondent)]
 EMPLOYER: [EMPNAME] ([BEGMO/BEGYR] – [ENDMO/ENDYR])
 ((And) the job with [EMPNAME] ([BEGMO/BEGYR] – [ENDMO/ENDYR]),...)
 On average, how many hours a week did [you / he / she] work on this job in [PYEAR]?
- ROUND DOWN for fractions less than ½ (0.5)
 - ROUND UP for fractions ½ (0.5) or more

1 – 112

BC44CKPT. CAI Checkpoint: Whether PYEAR Overtime Can Be Computed

1. Can't Compute Overtime (BCDEDKOTP1YR=1)	5. All Others	→ GO TO BC46
--	---------------	--------------

PYear Job and EmployEHC1.BCDEDkJobsP1Yr=1

- BC44. [CYNAMF CYNAML]: [CYAQRTH], [CYFUHU], Age [AGEIWDATE] [(Respondent)]
 EMPLOYER: [EMPNAME] ([BEGMO/BEGYR] – [ENDMO/ENDYR])
 ((And) the job with [EMPNAME] ([BEGMO/BEGYR] – [ENDMO/ENDYR]),...)
 Did [you / he / she] work any overtime [HRS/WK COMPUTED BUT OT NOT COMPUTED: (on this job in [PYEAR]) /
 HRS/WK & OT NOT COMPUTED: which isn't included in that]?

1. Yes 5. No → GO TO BC46



- BC45. [CYNAMF CYNAML]: [CYAQRTH], [CYFUHU], Age [AGEIWDATE] [(Respondent)]
 EMPLOYER: [EMPNAME] ([BEGMO/BEGYR] – [ENDMO/ENDYR])
 How many hours did that overtime amount to in (that period during) [PYEAR]?
- ENTER amount here, then SELECT unit of time on next screen (Week, Two weeks, Month, Year)
 - ROUND DOWN for fractions less than ½ (0.5)
 - ROUND UP for fractions ½ (0.5) or more

1 – 3760 DK/RF → GO TO BC46



- BC45PER. [CYNAMF CYNAML]: [CYAQRTH], [CYFUHU], Age [AGEIWDATE] [(Respondent)]
 EMPLOYER: [EMPNAME] ([BEGMO/BEGYR] – [ENDMO/ENDYR])
- The amount entered is: [BC45] per ____
 - SELECT the unit of time below

3. Week	4. Two weeks	5. Month	6. Year
7. Other-specify (BC45PERSPEC. Specify. (String 100))			

PYear Job

- BC46. [CYNAMF CYNAML]: [CYAQRTH], [CYFUHU], Age [AGEIWDATE] [(Respondent)]
 EMPLOYER: [EMPNAME] ([BEGMO/BEGYR] – [ENDMO/ENDYR])
 ((And) the job with [EMPNAME] ([BEGMO/BEGYR] – [ENDMO/ENDYR]),...)
 About how much did [you / he / she] make at this job in [PYEAR]?
- ENTER amount here, then SELECT unit of time on next screen (Hour, Day, Week, Two weeks, Month, Year)

\$ 1.0 – 9,999,997.99 DK/RF → GO TO BC47CKPT



BC46PER. [CYNAMF CYNAML]: [CYAQRTH], [CYFUHU], Age [AGEIWDATE] [(Respondent)]
 EMPLOYER: [EMPNAME] ([BEGMO/BEGYR] – [ENDMO/ENDYR])

- The amount entered is: [BC46] per ____
- SELECT the unit of time below

1. Hour	2. Day	3. Week	4. Two Weeks	5. Month	6. Year
7. Other-specify (BC46PERSPEC. Specify. (String 100))					

BC47CKPT. CAI Checkpoint: Whether Worked Job in P2YEAR; Whether P2YEAR Weeks or Hours/Week Can Be Computed

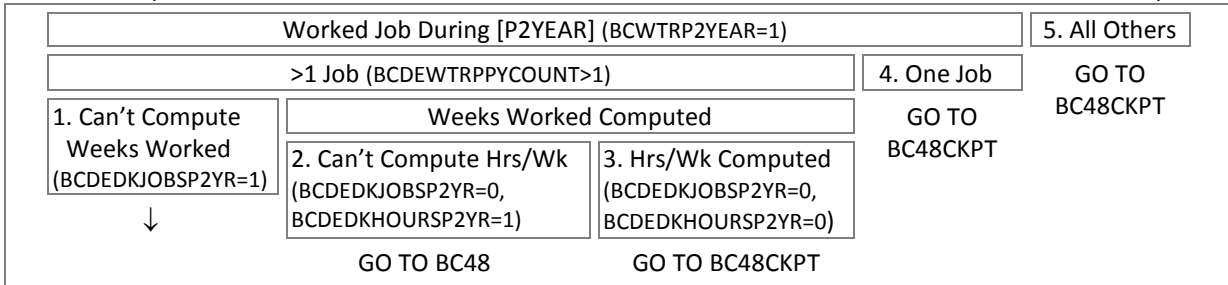

P2Year Job **and** EmployEHC1.BCDEdKJobsP2Yr=1

BC47A. [CYNAMF CYNAML]: [CYAQRTH], [CYFUHU], Age [AGEIWDATE] [(Respondent)]
 EMPLOYER: [EMPNAME] ([BEGMO/BEGYR] – [ENDMO/ENDYR])
 ((And) the job with [EMPNAME] ([BEGMO/BEGYR] – [ENDMO/ENDYR]),...)
 How many weeks out of the year did [you / RP / SP] actually work on this job in [P2YEAR]?

- IF R says "Every week except what (I / he / she) took off", ENTER [97]

1.0 – 52.0	97.0
------------	------

BC48CKPT. CAI Checkpoint: Whether P2YEAR Hours/Week Can Be Computed

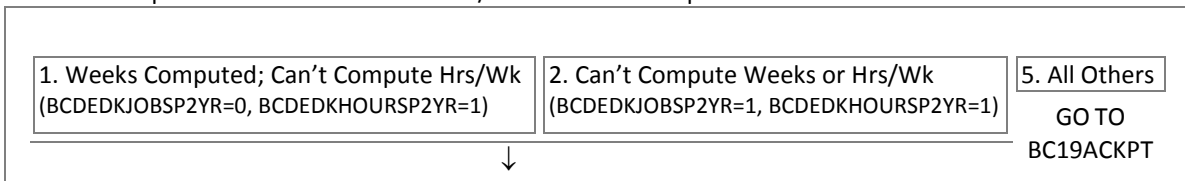

P2Year Job **and** EmployEHC1.BCDEdKJobsP2Yr=1

BC48. [CYNAMF CYNAML]: [CYAQRTH], [CYFUHU], Age [AGEIWDATE] [(Respondent)]
 EMPLOYER: [EMPNAME] ([BEGMO/BEGYR] – [ENDMO/ENDYR])
 ((And) the job with [EMPNAME] ([BEGMO/BEGYR] – [ENDMO/ENDYR]),...)
 On average, how many hours a week did [you / he / she] work on this job in [P2YEAR] ?

- ROUND DOWN for fractions less than ½ (0.5)
- ROUND UP for fractions ½ (0.5) or more

1 – 112

BC19ACKPT. CAI Checkpoint: Type of Interview (IWTYPE); Whether Same CMJ as Last Wave (BC18.SAMECMJPRELOAD); Whether Works for Someone Else Only (NEWPRELOAD.BC22, BC22)

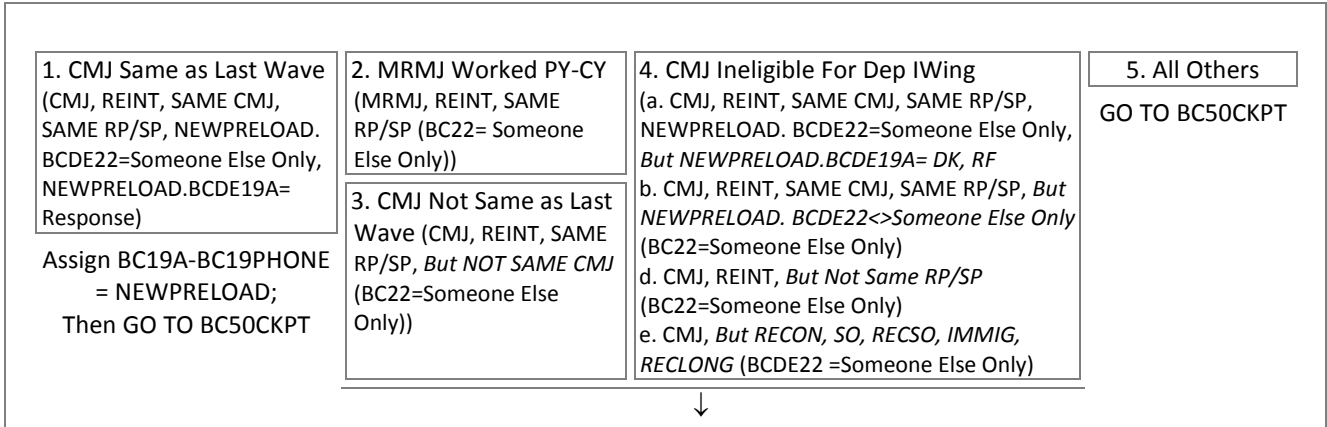

CMJ or PY-CY MRMJ and BC22=Works for Someone Else Only
 Reinterview-dependent interviewing: CMJ Not Same or CMJ But INEL or PY-CY MRMJ
 All Other IW Types: CMJ, or PY-CY MRMJ

BC19A. [CYNAMF CYNAML]: [CYAQRTH], [CYFUHU], Age [AGEIWDATE] [(Respondent)]
 EMPLOYER: [EMPNAME] [(BEGMO/BEGYR) – [ENDMO/ENDYR]]

[1st ITERATION: We would like to obtain information about characteristics of employers of our study members, such as benefits offered to employees. In order to do this, we need the full address of the place where [you work / [RP / SP] works] for [EMPNAME].

As you know, the information we collect is confidential, and that includes maintaining confidentiality in collecting information about employers. / 2nd ITERATION: As we mentioned earlier, we would like to obtain information about employer characteristics, such as benefits offered to employees.

In order to do this, we need the full address of the place where [you work / [SP]] works] for [EMPNAME].

- **If needed:** We would use the employer address to collect general information about [your / her] employer, such as number of workers or benefits offered to employees.]
- **If needed:** The information we collect is confidential, and that includes maintaining confidentiality in collecting information about employers.
- **If R knows just part of the address, ENTER [1]**
- **If R knows none of the address, ENTER [Ctrl-D]**

1. Continue [DK/RF] → GO TO BC50CKPT



<p>BC19ADDR1. [CYNAMF CYNAML]: [CYAQRTH], [CYFUHU], Age [AGEIWDATE] [(Respondent)] EMPLOYER: [EMPNAME] [(BEGMO/BEGYR) – [ENDMO/ENDYR]] What is the mailing address? Address 1</p> <ul style="list-style-type: none"> • Enter street address here • Enter PO Box at next screen • Ctrl-D and Ctrl-R not allowed; For DK/RF, PRESS [Enter] to continue <p>String 40</p>	<p>BC19STATE. [CYNAMF CYNAML]: [CYAQRTH], [CYFUHU], Age [AGEIWDATE] [(Respondent)] EMPLOYER: [EmpName] [(BegMo/BegYr) – [EndMo/EndYr]] State</p> <ul style="list-style-type: none"> • Start typing the name of the State to bring up the look-up list • If foreign country, ENTER [FOR] to select “Foreign Country” <p>String 30; String 4</p>
<p>BC19ADDR2. [CYNAMF CYNAML]: [CYAQRTH], [CYFUHU], Age [AGEIWDATE] [(Respondent)] EMPLOYER: [EMPNAME] [(BEGMO/BEGYR) –</p>	<p>BC19ZIP. [CYNAMF CYNAML]: [CYAQRTH], [CYFUHU], Age [AGEIWDATE] [(Respondent)] EMPLOYER: [EMPNAME] [(BEGMO/BEGYR) – [ENDMO/ENDYR]]</p>

<p>[ENDMO/ENDYR] Address 2</p> <ul style="list-style-type: none"> • Enter PO Box here • If none, PRESS [Enter] to continue • Ctrl-D and Ctrl-R not allowed; For DK/RF, PRESS [Enter] to continue <p>String 40</p> <p>BC19CITY. [CYNAMF CYNAML]: [CYAQRTH], [CYFUHU], Age [AGEIWDATE] [(Respondent)] EMPLOYER: [EMPNAME] [(BEGMO/BEGYR) – [ENDMO/ENDYR]] City</p> <ul style="list-style-type: none"> • Ctrl-D and Ctrl-R not allowed; For DK/RF type [DK] or [RF] <p>String 40</p>	<p>Zip Code</p> <ul style="list-style-type: none"> • If foreign country, ENTER all [0]'s • Ctrl-D and Ctrl-R not allowed; For DK/RF ENTER all [0]'s <p>-----</p> <p>BC19CNTRY. [CYNAMF CYNAML]: [CYAQRTH], [CYFUHU], Age [AGEIWDATE] [(Respondent)] EMPLOYER: [EMPNAME] [(BEGMO/BEGYR) – [ENDMO/ENDYR]] Country if different from USA</p> <ul style="list-style-type: none"> • Start typing the name of the Foreign Country to bring up the look-up list <p>String 30; String 2</p> <p>BC19PHONE. [CYNAMF CYNAML]: [CYAQRTH], [CYFUHU], Age [AGEIWDATE] [(Respondent)] EMPLOYER: [EMPNAME] [(BEGMO/BEGYR) – [ENDMO/ENDYR]] (And) the area code and phone number? Area Code and Telephone Number</p> <ul style="list-style-type: none"> • If foreign phone, ENTER all [0]'s • Ctrl-D and Ctrl-R not allowed; For DK/RF ENTER all [0]'s <p>(____)____-_____</p>
---	--

BC50CKPT. CAI Checkpoint: Whether Job Ended in P2YEAR-CYEAR

<p>1. Stopped Job P2YEAR or Later (BCCUR=0; or JOBTYP=MRMJ; or JOBTYP=Other , BCCUR=0)</p>	<p>5. All Others GO TO BC52CKPT</p>
<p>↓</p>	

Job Ended P2Year-CYear

BC51. [CYNAMF CYNAML]: [CYAQRTH], [CYFUHU], Age [AGEIWDATE] [(Respondent)]
EMPLOYER: [EMPNAME] [(BEGMO/BEGYR) – [ENDMO/ENDYR]]
((And) the job with [EMPNAME] [(BEGMO/BEGYR) – [ENDMO/ENDYR]],...)
Why did [you / he / she] stop working for [EMPNAME] [(BEGMO/BEGYR) – [ENDMO/ENDYR]]? Did the company go out of business, [were you / was [he / she]] laid off, did [you / he / she] quit, or what?

String 500

BC52CKPT. CAI Checkpoint: Whether More Jobs in EHC

<p>1. More Jobs → Repeat BC19-BC51; Max=10; Then GO TO BC60ACKPT</p>	<p>5. No More Jobs</p>
<p>↓</p>	

END BCJOBS

Time Use at Work

BC60ACKPT. CAI Checkpoint: Whether Currently Working

1. Currently Working (BCCUR=1 For Any Job)	5. All Others	→ GO TO BC61CKPT
↓		

BC60A. [CYNAMF CYNAML]: [CYAQRTH], [CYFUHU], Age [AGEIWDATE] [(Respondent)]

Current Employers:

[List of Current Employers from EHC]

These next questions are about the time [you spend / [RP / SP] spends] working in a typical week.

In a typical week, how many hours [do you / does [he /she]] spend working for pay?

- IF R report hours other than weekly, PROBE: About how many hours per week would you say that is?
- IF R reports a range, PROBE: Within that range, what is your best estimate?
- ROUND DOWN for fractions less than ½ (0.5)
- ROUND UP for fractions ½ (0.5) or more

0 None

1 – 111 Actual hours

112 112 Hours or more

0 – 112

BC60B. [CYNAMF CYNAML]: [CYAQRTH], [CYFUHU], Age [AGEIWDATE] [(Respondent)]

Current Employers:

[List of Current Employers from EHC]

While [you are / he is / she is] working, how often [do you / does [he /she]] interact with other people, including on the phone, in person, and online? Would you say never, rarely, sometimes, often, or almost always?

1. Never 2. Rarely 3. Sometimes 4. Often 5. Almost always or Always

BC60C. [CYNAMF CYNAML]: [CYAQRTH], [CYFUHU], Age [AGEIWDATE] [(Respondent)]

Current Employers:

[List of Current Employers from EHC]

While [you are / he is / she is] working, how often [do you / does [he /she]] perform physically demanding activities, for example, those that require strength or physical effort for long periods of time? Would you say never, rarely, sometimes, often, or almost always?

1. Never 2. Rarely 3. Sometimes 4. Often 5. Almost always or Always

BC60D. [CYNAMF CYNAML]: [CYAQRTH], [CYFUHU], Age [AGEIWDATE] [(Respondent)]

Current Employers:

[List of Current Employers from EHC]

(While [you are / he is / she is] working,...)

How often [do you / does [he /she]] perform mentally demanding activities, for example, analyzing information, learning new material, or solving complex problems?

(Would you say never, rarely, sometimes, often, or almost always?)

1. Never 2. Rarely 3. Sometimes 4. Often 5. Almost always or Always

BC60E. [CYNAMF CYNAML]: [CYAQRTH], [CYFUHU], Age [AGEIWDATE] [(Respondent)]

Current Employers:

[List of Current Employers from EHC]

(While [you are / he is / she is] working,...)

How often [do you / does [he /she]] feel rushed or pressed for time?

(Would you say never, rarely, sometimes, often, or almost always?)

1. Never 2. Rarely 3. Sometimes 4. Often 5. Almost always or Always

BC61CKPT. CAI Checkpoint: Type of Interview; Whether Did Not Work At All since 1/1/P2YEAR

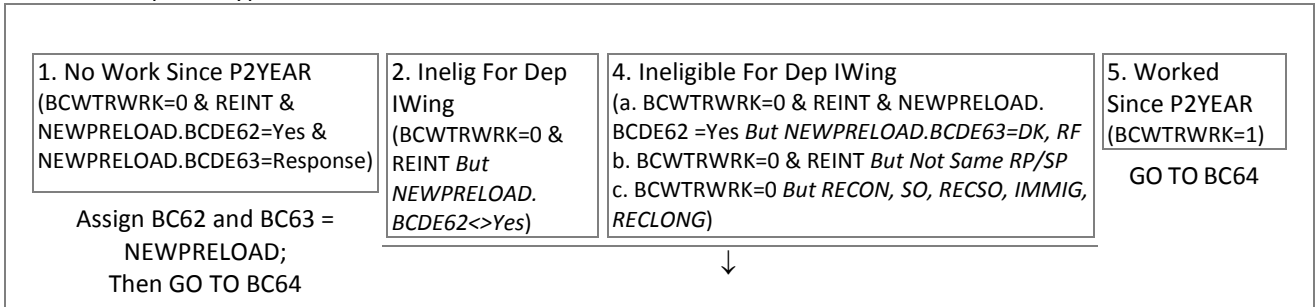

No Work Since P2Year

Reinterview-dependent interviewing: No Work Since P2Y But INEL

All Other IW Types: No Work Since P2Y

BC62. [CYNAMF CYNAML]: [CYAQRTH], [CYFUHU], Age [AGEIWDATE] [(Respondent)]

[Have you / Has [RP / SP]] ever done any work for money?

1. Yes 5. No → GO TO BC64



BC63.MONTH. [CYNAMF CYNAML]: [CYAQRTH], [CYFUHU], Age [AGEIWDATE] [(Respondent)]

In what month and year did [you / he / she] last work for money?

- **SELECT** Month and [Enter] to go to next screen for year
- **IF NECESSARY:** What would be your best estimate?

- | | | | | | |
|------------|-------------|--------------|-------------|--------------|--------------|
| 1. January | 2. February | 3. March | 4. April | 5. May | 6. June |
| 7. July | 8. August | 9. September | 10. October | 11. November | 12. December |
| 21. Winter | 22. Spring | 23. Summer | 24. Fall | | |

BC63.YEAR. [CYNAMF CYNAML]: [CYAQRTH], [CYFUHU], Age [AGEIWDATE] [(Respondent)]

(In what month and year did [you / he / she] last work for money?)

[BC63.MONTH], _____

- **ENTER** Year
- **ENTER [9997]** if before [P2YEAR] and DK exact year

- | | |
|-----------------|--------------------------------------|
| 1901 – [P3YEAR] | 9997. Before [P2YEAR], DK Exact Year |
|-----------------|--------------------------------------|

Looking for Work

BC64. [CYNAMF CYNAML]: [CYAQRTH], [CYFUHU], Age [AGEIWDATE] [(Respondent)]

[Have you / Has [RP / SP] been looking for [BCDE1=WORKING, LAID OFF or BCDE3=WORKING NOW: another job / ALL OTHERS: work] during the past four weeks?

1. Yes 5. No → GO TO BC68CKPT



BC65. [\[CYNAMF CYNAML\]: \[CYAQRTH\], \[CYFUHU\], Age \[AGEIWDATE\] \[\(Respondent\)\]](#)

What [have you / has [he / she]] been doing the last four weeks to find [another job / work]?

- IF R SAYS "Internet, website, on-line, on the computer" etc., PROBE for specific activity: What did [you / [RP / SP]] do - did [you / [RP / SP]] contact employers or agencies, check out potential employers without applying, or what?
- ENTER all that apply
- PROBE: Any others?

1. Checked with public employment agency	2. Checked with private employment agency
3. Checked with current employer directly	4. Checked with other employer directly
5. Checked with friends or relatives	6. Placed or answered ads
7. Other-specify (BC65SPEC. Specify. (String 100))	8. Nothing
9. Contacted school/university employment center	10. Checked union/professional registers
11. Sent out resumes/filled out applications	12. Attended job training programs/courses
13. Went on job interviews	14. Looked at ads or employers without applying
15. Used social media, e.g. Facebook, LinkedIn	

BC65ACKPT. CAI Checkpoint: Methods Used to Look for Work

1. Nothing, or Social Media Only, or Non-Response (BC65=8, 15 ONLY, DK/RF)	→ GO TO BC66CKPT	5. All Others
		↓

BC65A. [\[CYNAMF CYNAML\]: \[CYAQRTH\], \[CYFUHU\], Age \[AGEIWDATE\] \[\(Respondent\)\]](#)[Methods Reported](#)[\[List of BC65 Selections\]](#)

ASK or CONFIRM: When [you / he / she] searched, did [you / he / she] use the Internet (such as sending email or visiting websites)?

- If needed: Did [you / he / she] use the internet for any of the methods you mentioned?
- If needed: We're talking about the last 4 weeks

1. Yes	5. No	→ GO TO BC66CKPT
--------	-------	------------------

BC65B. [\[CYNAMF CYNAML\]: \[CYAQRTH\], \[CYFUHU\], Age \[AGEIWDATE\] \[\(Respondent\)\]](#)[Methods Reported](#)[\[List of BC65 Selections\]](#)

[Were you / Was [he / she]] required to use the internet, or were other options available (such as visiting, calling, or mailing materials)?

- ENTER [1] if R says the internet was required for some but not others
- If needed: We're talking about the last 4 weeks

1. Yes, required to use the internet	5. No, other options were available
--------------------------------------	-------------------------------------

BC66CKPT. CAI Checkpoint: Whether Currently Working

1. Not Currently Working (BC15CKPT=3, 4, 5)	5. All Others	→ GO TO BC68CKPT
		↓

BC67. [CYNAMF CYNAML]: [CYAQRTH], [CYFUHU], Age [AGEIWDATE] [(Respondent)]

How long [have you / has [he / she]] been looking for work?

- USE Years for amounts given in whole years
- USE Months and Weeks for amounts less than one year
- USE 1 week for amounts of one week or less

BC67.YEARS

BC67.MONTHS

BC67.WEEKS

Not Working and Not Looking for Work

BC68CKPT. CAI Checkpoint: Whether Currently Working; Whether Looking for Work

<input type="text" value="1. Not Currently Working (BC15CKPT=3, 4, 5) & Not Looking (BC64=5, DK/RF)"/>	<input type="text" value="5. All Others"/>	→ GO TO BC END RULE
↓		

BC68. [CYNAMF CYNAML]: [CYAQRTH], [CYFUHU], Age [AGEIWDATE] [(Respondent)]

What is the main reason [you were / he was / she was] not looking for work during the last four weeks?

- If R gives multiple reasons, PROBE: Which of those would be the main reason?

<input type="text" value="1. Believe no work available in area that R likes"/>	<input type="text" value="2. Couldn't find any work"/>	
<input type="text" value="3. Lack necessary schooling/training"/>	<input type="text" value="4. Employers think too young"/>	
<input type="text" value="5. Other types of discrimination"/>	<input type="text" value="6. In school or training"/>	
<input type="text" value="7. Transportation problems"/>	<input type="text" value="8. Family responsibilities"/>	
<input type="text" value="9. Can't arrange child care"/>	<input type="text" value="10. Disability"/>	<input type="text" value="11. Retired"/>
<input type="text" value="97. Other-specify (BC68SPEC. Specify (String 500))"/>		

BC END Rule. Whether Spouse/Partner in FU

<input type="text" value="Spouse/Partner (CYAQRTH=201-222, CYFUHU=FU, FUMI)"/>	→ Repeat SECTION BC; Then GO TO SECTION F	<input type="text" value="No Spouse/Partner"/>
		GO TO SECTION F

END SECTION_BC

Section F: Expenditures

[TOC](#)

SECTION_F

F1. Now I have a few questions about housework and food costs. [*R=RP, SP, OFUM*: For these questions, when I refer to “family”, I mean your family living there with you.]

- [ENTER \[1\] to continue](#)

1. Continue

F1ACKPT. CAI Checkpoint: Whether Single Reference Person or Reference Person + Spouse/Partner in FU

1. Male Reference Person + Spouse/Partner (CYAQRTH[1]=101; CYFUHU=FU, FUMI & CYAQRTH[2]=201-222; CYFUHU=FU, FUMI)	2. Male Reference Person, No Spouse/Partner (CYAQRTH[1]=101; CYFUHU=FU, FUMI)
3. Female Reference Person, No Spouse/Partner (CYAQRTH[1]=102; CYFUHU=FU, FUMI)	4. Female Reference Person + Spouse/Partner (CYAQRTH[1]=102; CYFUHU=FU, FUMI & CYAQRTH[2]=201-222; CYFUHU=FU, FUMI)

Time Use Outside of Work

SECTION_F.F1A_F1K [1-2] [*1*]=Current Reference Person, [*2*]=Current Spouse/Partner

AQSN. AQSN of Current Reference Person (Spouse/Partner)

F1A. (F2, F3) [*CYNAMF CYNAML*]: [*CYAQRTH*], [*CYFUHU*], Age [*AGEIWDATE*] [(Respondent)]

These next few questions are about how [you spend/ [RP] spends / [SP spends]] [your / his / her] time [*CURRENTLY WORKING*: when [you are / he is /she is] not working].

In a typical week, how many hours [do you / does [he / she]] spend doing housework, for example, cooking, cleaning, and other work around the house?

- [IF R report hours other than weekly, PROBE](#): About how many hours per week would you say that is?
- [IF R reports a range, PROBE](#): Within that range, what is your best estimate?
- [ROUND DOWN](#) for fractions less than ½ (0.5)
- [ROUND UP](#) for fractions ½ (0.5) or more

0 None

1 – 111 Actual hours

112 112 Hours or more

0 – 112

F1B. [CYNAMF CYNAML]: [CYAQRTH], [CYFUHU], Age [AGEIWDATE] [(Respondent)]

(In a typical week, how many hours [do you / does [he / she]] spend)

Doing personal care activities, for example, grooming, getting ready for the day, or taking care of [your / his / her] health needs?

- IF R report hours other than weekly, PROBE: About how many hours per week would you say that is?
- IF R reports a range, PROBE: Within that range, what is your best estimate?
- ROUND DOWN for fractions less than $\frac{1}{2}$ (0.5)
- ROUND UP for fractions $\frac{1}{2}$ (0.5) or more

0 None

1 – 111 Actual hours

112 112 Hours or more

0 – 112

F1C. [CYNAMF CYNAML]: [CYAQRTH], [CYFUHU], Age [AGEIWDATE] [(Respondent)]

(In a typical week, how many hours [do you / does [he / she]] spend)

Shopping, for example, buying groceries or clothes, or shopping online?

- IF R report hours other than weekly, PROBE: About how many hours per week would you say that is?
- IF R reports a range, PROBE: Within that range, what is your best estimate?
- ROUND DOWN for fractions less than $\frac{1}{2}$ (0.5)
- ROUND UP for fractions $\frac{1}{2}$ (0.5) or more

0 None

1 – 111 Actual hours

112 112 Hours or more

0 – 112

F1D. [CYNAMF CYNAML]: [CYAQRTH], [CYFUHU], Age [AGEIWDATE] [(Respondent)]

(In a typical week, how many hours [do you / does [he / she]] spend)

Caring for or looking after children? [*CURRENTLY WORKING*: Exclude hours providing care if this is [your / his / her] job.]

- IF R reports 24/7, ENTER [168]
- IF R report hours other than weekly, PROBE: About how many hours per week would you say that is?
- IF R reports a range, PROBE: Within that range, what is your best estimate?
- ROUND DOWN for fractions less than $\frac{1}{2}$ (0.5)
- ROUND UP for fractions $\frac{1}{2}$ (0.5) or more

0 None

1 – 168 Actual hours

0 – 168

F1D2. [CYNAMF CYNAML]: [CYAQRTH], [CYFUHU], Age [AGEIWDATE] [(Respondent)]

(In a typical week, how many hours [do you / does [he / she]] spend)

Caring for or looking after an adult who needs assistance with daily activities? [*CURRENTLY WORKING*: Exclude hours providing care if this is [your / his / her] job.]

- IF R reports 24/7, ENTER [168]
- IF R report hours other than weekly, PROBE: About how many hours per week would you say that is?
- IF R reports a range, PROBE: Within that range, what is your best estimate?
- ROUND DOWN for fractions less than $\frac{1}{2}$ (0.5)
- ROUND UP for fractions $\frac{1}{2}$ (0.5) or more

0 None

1 – 168 Actual hours

0 – 168

F1E. [CYNAMF CYNAML]: [CYAQRTH], [CYFUHU], Age [AGEIWDATE] [(Respondent)]

(In a typical week, how many hours [do you / does [he / she]] spend)

Volunteering, for example, at religious organizations, schools, hospitals, charities, or community organizations?

- IF R report hours other than weekly, PROBE: About how many hours per week would you say that is?
- IF R reports a range, PROBE: Within that range, what is your best estimate?
- ROUND DOWN for fractions less than ½ (0.5)
- ROUND UP for fractions ½ (0.5) or more

0 None

1 – 111 Actual hours

112 112 Hours or more

0 – 112

F1F. [CYNAMF CYNAML]: [CYAQRTH], [CYFUHU], Age [AGEIWDATE] [(Respondent)]

(In a typical week, how many hours [do you / does [he / she]] spend)

Doing educational activities, for example, taking classes, doing homework, or studying for exams? [*>1 FU MEMBER*:

Exclude time spent helping others with homework.]

- IF R report hours other than weekly, PROBE: About how many hours per week would you say that is?
- IF R reports a range, PROBE: Within that range, what is your best estimate?
- ROUND DOWN for fractions less than ½ (0.5)
- ROUND UP for fractions ½ (0.5) or more

0 None

1 – 111 Actual hours

112 112 Hours or more

0 – 112

F1G. [CYNAMF CYNAML]: [CYAQRTH], [CYFUHU], Age [AGEIWDATE] [(Respondent)]

(In a typical week, how many hours [do you / does [he / she]] spend)

Doing leisure activities for enjoyment, for example, watching TV, doing physical activities that [you enjoy/ [he / she] enjoys], going online, or spending time with friends?

- IF R report hours other than weekly, PROBE: About how many hours per week would you say that is?
- IF R reports a range, PROBE: Within that range, what is your best estimate?
- ROUND DOWN for fractions less than ½ (0.5)
- ROUND UP for fractions ½ (0.5) or more

0 None

1 – 111 Actual hours

112 112 Hours or more

0 – 112

F1H. [CYNAMF CYNAML]: [CYAQRTH], [CYFUHU], Age [AGEIWDATE] [(Respondent)]

Now think about all the activities [you do / [he / she] does] in a typical week [*CURRENTLY WORKING*: outside of work, that is, when [you are / [he / she] is] not working].

[*CURRENTLY WORKING*: Outside of work, how / *ALL OTHERS*: How] often [do you / does [he / she]] interact with other people, including on the phone, in person, and online? Would you say never, rarely, sometimes, often, or almost always?

Never Rarely Sometimes Often Almost Always or Always

F1I. [CYNAMF CYNAML]: [CYAQRTH], [CYFUHU], Age [AGEIWDATE] [(Respondent)]

[*CURRENTLY WORKING*: Outside of work, how / *ALL OTHERS*: How] often [do you / does [he / she]] perform physically demanding activities, for example, those that require strength or physical effort for long periods of time? Would you say never, rarely, sometimes, often, or almost always?

Never Rarely Sometimes Often Almost Always or Always

F1J. [CYNAMF CYNAML]: [CYAQRTH], [CYFUHU], Age [AGEIWDATE] [(Respondent)]

[CURRENTLY WORKING: Outside of work, how / ALL OTHERS: How] often [do you / does [he / she]] perform mentally demanding activities, for example, analyzing information, learning new material, or solving complex problems? (Would you say never, rarely, sometimes, often, or almost always?)

Never Rarely Sometimes Often Almost Always or Always

F1K. [CYNAMF CYNAML]: [CYAQRTH], [CYFUHU], Age [AGEIWDATE] [(Respondent)]

[CURRENTLY WORKING: Outside of work, how / ALL OTHERS: How] often [do you / does [he / she]] feel rushed or pressed for time? (Would you say never, rarely, sometimes, often, or almost always?)

Never Rarely Sometimes Often Almost Always or Always

F1K END Rule: Whether Spouse/Partner in FU

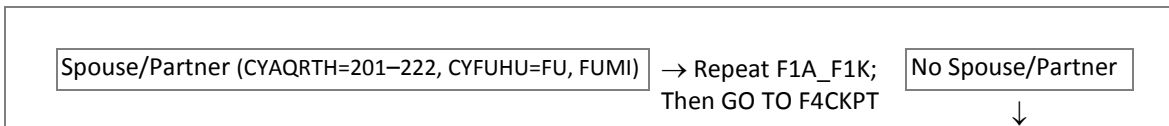

END F1A_F1K

F4CKPT. CAI Checkpoint: Number of Current FU Members

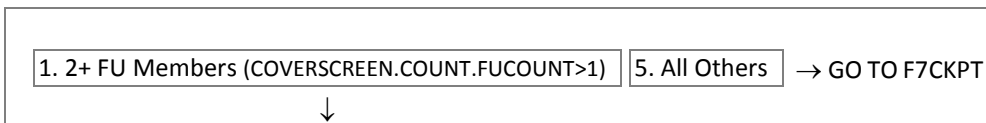

Family Meals

F5. How many days a week does the family sit down and eat the main meal of the day together?

0–7

F7CKPT. CAI Checkpoint: Whether Children Age 5–18 in FU in PYEAR

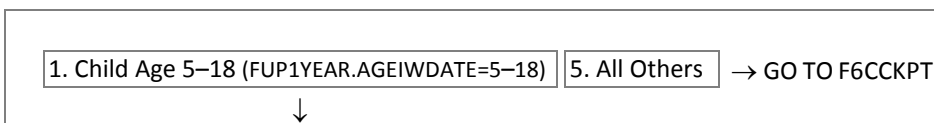

Child and Elder Care and Food

F6AB. And during [PYEAR], did [1 CHILD IN FU PYEAR: [CYNAMF CYNAML] / ALL OTHERS: any child in your family between 5 and 18 years old] receive free or reduced-cost breakfasts or lunches at school? If “Yes”: Was that breakfast, lunch, or both?

1. Yes, breakfast only 2. Yes, lunch only 3. Yes, both 5. No, neither

F6CKPT. CAI Checkpoint: Whether Children Age 15 or Younger in FU in PYEAR

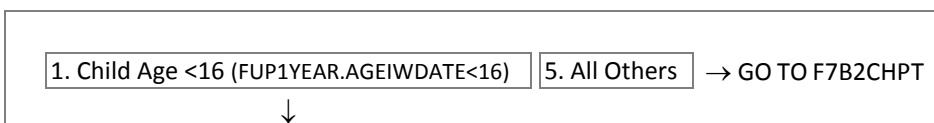

F7. How much did you [and your family living there] pay for child care in [PYEAR]?

- ENTER amount here, then SELECT unit of time on next screen (Week, Two weeks, Month, Year)

→ GO TO F7A → GO TO F7MO



F7PER. The amount entered is: [F6D] per _____

- SELECT the unit of time below

F7MO. For which months in [PYEAR] was that?

- ENTER all that apply
- PROBE: Any others?

F7A. Was any child enrolled in a day care center or family day care home in [PYEAR]?

 → GO TO F7B2CHPT



F7B. Were meals or snacks provided in any of these day care arrangements (attended last year)?

 → GO TO F7B2CHPT



F7B1. Did that day care center or family day care home participate in any government-sponsored food program, such as the Child and Adult Care Food Program?

F7B2CHPT. CAI Checkpoint: Whether Female Age 16–46 or Children Age 5 or Younger in FU in PYEAR



GO TO F7CCKPT

F7B2. And during [PYEAR], did anyone in your family get food through the WIC program?

F7CCKPT. CAI Checkpoint: Whether FU Member Age 61 or Older in FU in PYEAR

 → GO TO F8



F7C. During [PYEAR], did you [or anyone in your family] receive free or reduced-cost meals for the elderly?

Food Stamps

F8. Did you [or anyone else in your family] receive food stamp benefits, that is, either food stamps or a food stamp benefit card, at any time in [P2YEAR], two years ago?

- **If needed:** Food stamp benefits are issued by SNAP, the federal Supplemental Nutrition Assistance Program, also called Food Stamp Program.

1. Yes 5. No

F11. Did you [or anyone else in your family] receive food stamp benefits, (that is, either food stamps or a food stamp benefit card,) at any time last year, in [PYEAR]?

- **If needed:** Food stamp benefits are issued by SNAP, the federal Supplemental Nutrition Assistance Program, also called Food Stamp Program.

1. Yes 5. No → GO TO F14



F12. How much did you receive (in food stamp benefits) in [PYEAR]?

- **If needed:** Food stamp benefits are issued by SNAP, the federal Supplemental Nutrition Assistance Program, also called Food Stamp Program.
- **ENTER amount here, then SELECT unit of time on next screen (Week, Two weeks, Month, Year)**

→ GO TO F13



F12PER. The amount entered is: [F12] per _____

- **SELECT the unit of time below**

3. Week 4. Two weeks 5. Month 6. Year

7. Other-specify (F12PERSPEC. Specify. (String 100))

F13. During which months was that?

- **ENTER all that apply**
- **PROBE:** Any others?

1. January 2. February 3. March 4. April 5. May 6. June
 7. July 8. August 9. September 10. October 11. November 12. December 13. All

(Section_F.xF14aDisplay=0; F14A not included)

F14. Did you [or anyone else now living in your family] use food stamp benefits last month?

- **If needed:** Food stamp benefits are issued by SNAP, the federal Supplemental Nutrition Assistance Program, also called Food Stamp Program.
- **ENTER [1] if R says food stamps were not received - or were received early – because of the federal government shutdown**

1. Yes 5. No → GO TO F18F22



F15. How many members of your family were covered (by food stamp benefits)?

- **If needed:** Food stamp benefits are issued by SNAP, the federal Supplemental Nutrition Assistance Program, also called Food Stamp Program.
- **ENTER [7] for seven or more family members**

F16. How much did you receive (in food stamp benefits) last month?

- **If needed:** Food stamp benefits are issued by SNAP, the federal Supplemental Nutrition Assistance Program, also called Food Stamp Program.

F17. In addition to what you buy with food stamp benefits, do you [or anyone else in your family] spend any money on food that you use at home?

- **If needed:** Food stamp benefits are issued by SNAP, the federal Supplemental Nutrition Assistance Program, also called Food Stamp Program.

→ GO TO F19F23



Food

F18F22. [F14=YES: How much do you spend on that food in an average week? / ALL OTHERS: How much do you [and everyone else in your family] spend on food that you use at home in an average week?]

- [HU/CS IN FU: IF R lives with non-FU members, PROBE: Is that only your (FU's) share of the food?]
- **ENTER amount here, then SELECT unit of time on next screen (Week, Two weeks, Month, Year)**

→ GO TO F19F23 → GO TO F19F23



F18F22PER. The amount entered is: [F18F22] per ____

- **SELECT the unit of time below**

F19F23. Do you have any food delivered to the door which isn't included in that?

→ GO TO F21F25



F20F24. How much do you spend on that food?

- [HU/CS IN FU: IF R lives with non-FU members, PROBE: Is that only your (FU's) share of the food?]
- **ENTER amount here, then SELECT unit of time on next screen (Week, Two weeks, Month, Year)**

→ GO TO F21F25



F20F24PER. The amount entered is: [F20F24] per ____

- **SELECT the unit of time below**

F21F25. About how much do you [and everyone else in your family] spend eating out?

- [HU/CS IN FU: IF R lives with non-FU members, PROBE: Is that only your (FU's) share of the food?]
- ENTER amount here, then SELECT unit of time on next screen (Week, Two weeks, Month, Year)

→ GO TO FOOD1 → GO TO FOOD1



F21F25PER. The amount entered is: [F21F25] per _____

- SELECT the unit of time below

FOOD1CKPT. CAI Checkpoint: Who is Respondent

→ GO TO F47



Food Security

SECTION_F.FOOD

Household Stage 1

FOOD1. Now I'm going to read you several statements that people have made about their food situation. For these statements, please tell me whether the statement was often true, sometimes true, or never true for [you / your household] in the last 12 months - that is, since last [CURRMONTH].

The first statement is "[NO SP IN FU: I / SP IN FU: We] worried whether [NO SP IN FU: my / SP IN FU: our] food would run out before [NO SP IN FU: I / SP IN FU: we] got money to buy more."

Was that often true, sometimes true, or never true for [NO SP IN FU: you / SP IN FU: your household] in the last 12 months?

FOOD2. "The food that [I / we] bought just didn't last, and [I / we] didn't have money to get more."

(Was that often, sometimes, or never true for [you / your household] in the last 12 months?)

FOOD3. "[I / We] couldn't afford to eat balanced meals."

(Was that often, sometimes, or never true for [you / your household] in the last 12 months?)

Household Stage 2

FOOD4 Rule: Whether Any Food1 – Food3 Endorsed As Often/Sometimes

→ GO TO FOOD11CKPT



FOOD4. In the last 12 months, since last [CURRMONTH], did [you / you or other adults in your household] ever cut the size of your meals or skip meals because there wasn't enough money for food?

→ GO TO FOOD6



FOOD5. How often did this happen - almost every month, some months but not every month, or in only 1 or 2 months?

1. Almost every month 2. Some months but not every month 3. Only 1 or 2 months

FOOD6. In the last 12 months, (since last [CURRMONTH]), did you ever eat less than you felt you should because there wasn't enough money for food?

1. Yes 5. No

FOOD7. In the last 12 months, (since last [CURRMONTH]), were you ever hungry but didn't eat because there wasn't enough money for food?

1. Yes 5. No

FOOD8. In the last 12 months, did you lose weight because there wasn't enough money for food?

1. Yes 5. No

Household Stage 3

FOOD9 Rule: Whether Any Food4, Food6, Food7, Food8 Endorsed

One or More FOOD4, FOOD6, FOOD7, or FOOD8 = Yes All Others → GO TO FOOD11CKPT



FOOD9. In the last 12 months, (since last [CURRMONTH]), did [you / you or other adults in your household] ever not eat for a whole day because there wasn't enough money for food?

1. Yes 5. No → GO TO FOOD11CKPT



FOOD10. How often did this happen - almost every month, some months but not every month, or in only 1 or 2 months?

1. Almost every month 2. Some months but not every month 3. Only 1 or 2 months

Child Stage 1

FOOD11CKPT. CAI Checkpoint: Whether Children Age 0–17 in FU

1. There are One or More Children in FU (CYAQRTH<>101-222,881-882,901-922; CYFUHU=FU, FUMI; AGEIWDAT<18) 5. All Others → GO TO F47



FOOD11. Now I'm going to read you several statements that people have made about the food situation of their children.

For these statements, please tell me whether the statement was often true, sometimes true, or never true in the last 12 months for your [child / children living in the household who are under 18 years old].

"[I / We] relied on only a few kinds of low-cost food to feed [my / our] [1 CHILD: child / >1 CHILD: children] because [I was / we were] running out of money to buy food."

Was that often, sometimes, or never true for [you / your household] in the last 12 months, (since last [CURRMONTH])?

1. Often true 2. Sometimes true 3. Never true

FOOD12. "[I / We] couldn't feed [my / our] [child / children] a balanced meal, because [I / we] couldn't afford that."
(Was that often, sometimes, or never true for [you / your household] in the last 12 months, (since last [CURRMONTH]))?

1. Often true 2. Sometimes true 3. Never true

FOOD13. "[My / Our] [child was / children were] not eating enough because [I / we] just couldn't afford enough food."
(Was that often, sometimes, or never true for [you / your household] in the last 12 months, (since last [CURRMONTH]))?

1. Often true 2. Sometimes true 3. Never true

Child Stage 2

FOOD14 Rule: Whether Any Food11 – Food13 Endorsed As Often/Sometimes

One or More FOOD11, FOOD12, or FOOD13 = Often True or Sometimes True All Others → GO TO F47



FOOD14. In the last 12 months, since [CURRMONTH] of last year, did you ever cut the size of [your child's / any of the children's] meals because there wasn't enough money for food?

1. Yes 5. No

FOOD15. In the last 12 months, (since last [CURRMONTH]), did [your child / any of the children] ever skip meals because there wasn't enough money for food?

1. Yes 5. No → GO TO FOOD17



FOOD16. How often did this happen?

(Would you say almost every month, some months but not every month, or in only 1 or 2 months?)

1. Almost every month 2. Some months but not every month 3. Only 1 or 2 months

FOOD17. In the last 12 months, (since last [CURRMONTH]), [was your child / were the children] ever hungry but you just couldn't afford more food?

1. Yes 5. No

FOOD18. In the last 12 months, (since last [CURRMONTH]), did [your child / the children] ever not eat for a whole day because there wasn't enough money for food?

1. Yes 5. No

END FOOD

Vehicles

F47. These next questions are about personal vehicles and transportation. Do you [or anyone else in your family living there] own or lease a car or other vehicle for personal use?

- DO NOT include motorcycles or vehicles used exclusively by institutionals, HU or HUCS people

1. Yes 5. No → GO TO F81A



F48. Altogether, how many vehicles do you [or anyone else in your family living there] own or lease (for your personal use)?

- DO NOT include motorcycles or vehicles used exclusively by institutionals, HU or HUICS people

→ GO TO F81A



SECTION_F.F49SERIES.F49[1-3] [1-3]=Which vehicle

F49A. [VEHICLE 1: I would like to ask a few questions about [F48=1: that vehicle / F48>1: those vehicles, starting with the one most recently acquired]. / ALL OTHERS: For the next vehicle:]

What is the year?

F49B. What is the make and model of the vehicle?

- PROBE if multiple models are listed with the same name
- PROBE for hybrid or non-hybrid as needed. If R doesn't know, SELECT the non-hybrid model

→ GO TO F49BCKPT



F49B1. Hybrid Indicator from Car Database (0, 1)

F49C. 8-Digit Vehicle Model ID from Car Database

F49BCKPT. CAI Checkpoint: Whether Vehicle is Hybrid; Whether Vehicle Older Than 1999

GO TO F53 RULE



F49B2. [F49A F49B]

Is this vehicle a hybrid, plug-in hybrid, electric-only, or alternative fuel use vehicle, or none of the above?

- If R says Yes, PROBE: Is it a hybrid, plug-in hybrid, electric, or alternative fuel?

EV: Electric vehicle

BEV: Battery electric vehicle

CNG: Compressed natural gas

LPG: Liquified petroleum gas

F53 Rule: Whether More Vehicles at F48

→ Repeat F49; Max=3;
Then GO TO F53



END F49

SECTION_F.VEHICLE [1-3] [1-3]=Which vehicle

F53. [YEAR MAKE-MODEL]

(And) for your [F49B=DK/RF: [first / second / third] vehicle / ALL OTHERS: [F49B]], did you buy it, lease it, receive it as a gift, or what?

1. Bought 2. Leased 3. Received as a gift

7. Other-specify (F53SPEC. Specify. (String 100)) DK/RF → GO TO F75 RULE



F55. [YEAR MAKE-MODEL]

In what year did you [F53=BOUGHT: buy / F53=LEASED: lease / F53=GIFT: receive / F53=OTHER: acquire] it?

1901 – [CYEAR]

F57. [YEAR MAKE-MODEL]

Not counting routine use to get to and from work, is this vehicle also used for business purposes?

1. Yes 5. No → GO TO F60 RULE



F58. [YEAR MAKE-MODEL]

Is it used primarily for business purposes?

- DEFINITION: more than half of the miles driven per year are for business

1. Yes 5. No

F60 Rule: Whether This Vehicle Bought or Leased in P2YEAR–CYEAR

Bought P2YEAR-CYEAR (F53=1 & F55≥P2YEAR)	Leased P2YEAR-CYEAR (F53=2 & F55≥P2YEAR)	→ GO TO F71 RULE	All Others	→ GO TO F75 RULE
↓				

F61. [YEAR MAKE-MODEL]

What was the total price of the [F49B=DK/RF: [first / second / third] vehicle / ALL OTHERS: [F49B]]?

\$ 1 – 999,997

F64. [YEAR MAKE-MODEL]

How much did you pay down in cash?

- IF necessary: Over and above the value of your trade-in or sale.

\$ 0 – 999,997

F65. [YEAR MAKE-MODEL]

Did you borrow or finance part of the total price?

1. Yes 5. No → GO TO F75 RULE



F66. [YEAR MAKE-MODEL]

How much did you borrow, not including financing charges?

\$ 1 – 999,997

F67. [YEAR MAKE-MODEL]

How much are your current payments and how often are they made?

- ENTER [0] if paid off
- ENTER amount here, then SELECT unit of time on next screen (Two weeks, Month, Year)

→ GO TO F75 RULE → GO TO F75 RULE



F67PER. The amount entered is: [F67] per ____

- SELECT the unit of time below

F69. [YEAR MAKE-MODEL]

How many payments did you agree to make altogether?

[Monthly payments conversions](#)

3 years = 36 6 years = 72

4 years = 48 7 years = 84

5 years = 60

F70. [YEAR MAKE-MODEL]

How many payments have you made?

[Monthly payments conversions](#)

3 years = 36 6 years = 72

4 years = 48 7 years = 84

5 years = 60

F71 Rule: Whether This Vehicle Leased in P2YEAR–CYEAR

<input type="text" value="Leased P2YEAR-CYEAR (F53=2 & F55≥P2YEAR)"/>	<input type="text" value="All Others"/>	→ GO TO F75 RULE
---	---	------------------

↓

F71. [YEAR MAKE-MODEL]

(And for your [F49B=DK/RF: [first / second / third] vehicle / ALL OTHERS: [F49B]],) how much was your initial outlay for that lease - including your down payment and any fees?

F72. [YEAR MAKE-MODEL]

How much are your payments and how often are they made?

- ENTER amount here, then SELECT unit of time on next screen (Two weeks, Month, Year)

→ GO TO F75 RULE



F72PER. The amount entered is: [F72] per ____

- SELECT the unit of time below

F73. [YEAR MAKE-MODEL]

How many payments did you agree to make altogether?

[Monthly payments conversions](#)

3 years = 36 6 years = 72

4 years = 48 7 years = 84

5 years = 60

1 – 200

F74. [YEAR MAKE-MODEL]

How many payments have you made?

[Monthly payments conversions](#)

3 years = 36 6 years = 72

4 years = 48 7 years = 84

5 years = 60

0 – 200

F75 Rule: Whether More Vehicles at F48

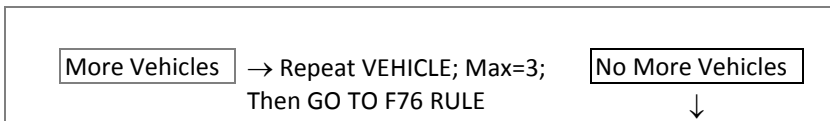

END VEHICLE

F76 Rule: Whether FU Has a Vehicle

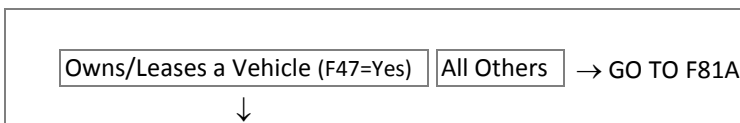

Other Expenses

Car Insurance, Repairs and Other Transportation

F77. [ALL VEHICLES: YEAR MAKE-MODEL]

How much do you [and your family living there] pay for car insurance [F48=2+, DK: for all of your vehicles]?

- IF necessary: Please give me your best estimate.
- ENTER amount here, then SELECT unit of time on next screen (Every 6 months, Month, Year)

→ GO TO F80D

 → GO TO F80D

↓

F77PER. The amount entered is: [F77] per ____

- SELECT the unit of time below

F80D. How much did you [and your family living there] pay for car repairs and maintenance in the last 12 months?

- If needed: We're talking about the last 12 months
- ENTER to the nearest dollar.
- If None, ENTER [0]

F78 Rule: Whether Any Vehicle Bought or Leased Before P2YEAR

Vehicle Bought/Leased Before P2YEAR (F53=1-2 & F55<P2YEAR)	All Others	→ GO TO F80B
↓		

F79. [Vehicles Bought/Leased < [P2YEAR]: YEAR MAKE-MODEL]

[ANY VEHICLE BOUGHT/LEASED [P2YEAR] OR LATER: Other than the car payments you already told me about, how / ALL OTHERS: How] much did you [and your family living there] pay in car payments in [LAST MONTH]?

- If needed: We're talking about last month ([LAST MONTH])
- INCLUDE vehicle purchase and lease payments not already covered

\$ 0 – 999,997

F80B. Altogether for the month of [LAST MONTH], how much did you [and your family living there] pay for each of these transportation related expenses. Do not include costs associated with trips and vacations, which we will ask about later.

Gasoline?

- If needed: We're talking about last month ([LAST MONTH])
- ENTER to the nearest dollar.
- If None, ENTER [0]

\$ 0 – 99,997

F80C. (Altogether for the month of [LAST MONTH], how much did you [and your family living there] pay for each of these transportation related expenses. Do not include costs associated with trips and vacations, which we will ask about later.)

Parking and car pool?

- If needed: We're talking about last month ([LAST MONTH])
- ENTER to the nearest dollar.
- If None, ENTER [0]

\$ 0 – 99,997

F81A. [F47=YES: (Altogether for the month of [LAST MONTH], how much did you [and your family living there] pay for each of these transportation related expenses. Do not include costs associated with trips and vacations, which we will ask about later.) / F47<>YES: Altogether for the month of [LAST MONTH], how much did you [you and your family living there] pay for each of these transportation related expenses. Do not include costs associated with trips and vacations, which we will ask about later.]

Bus fares and train fares?

- If needed: We're talking about last month ([LAST MONTH])
- ENTER to the nearest dollar.
- If None, ENTER [0]

\$ 0 – 99,997

F81B. (Altogether for the month of [LAST MONTH], how much did you [and your family living there] pay for each of these transportation related expenses. Do not include costs associated with trips and vacations, which we will ask about later.)

Taxicabs?

- If needed: Please include ride sharing services like Uber and Lyft
- If needed: We're talking about last month ([LAST MONTH])
- ENTER to the nearest dollar.
- If None, ENTER [0]

\$ 0 – 99,997

F81C. (Altogether for the month of [LAST MONTH], how much did you [and your family living there] pay for each of these transportation related expenses. Do not include costs associated with trips and vacations, which we will ask about later.)

Other transportation costs?

- **If needed:** We're talking about last month ([LAST MONTH])
- **ENTER to the nearest dollar.**
- **If None, ENTER [0]**

→ GO TO F82



F81CSPEC. What were those other costs?

Education

F82. In [PYEAR], did you [and your family living there] have any school-related expenses such as:

Tuition or tutoring (not including any amounts already mentioned for day care or nursery school);

Room and board for a family member who is away at school;

Purchase or rental of books, supplies, uniforms, or equipment including computers and software?

→ GO TO F86A



F83. How much in total were these expenses?

F84. In [PYEAR], were there any other school-related expenses not already covered in the previous question?

→ GO TO F86A



F85. What other types of school-related expenses did you have?

F86. Altogether, how much were these other expenses?

Devices and Software

F86A. [*F82=YES OR F84=YES*: Not including any amounts already reported, how / *ALL OTHERS*: How] much did you [and your family living there] spend altogether in [PYEAR] on computers, laptops, tablets, cell phones, game players, and software for these devices?

- **IF needed:** Do not include cell phone or internet service

→ GO TO F87



F86A1. Would it amount to \$600 or more?

 → GO TO F87



F86A3. (Would it amount to) \$900 or more? F86A2. (Would it amount to) \$400 or more?

Home Repairs and Maintenance

F87. Next, let me ask you about some other household expenses. Please indicate to the best of your ability, the amount spent on each of these items altogether during [PYEAR].

How much did you [and your family living there] spend altogether in [PYEAR] on home repairs and maintenance, including materials plus any costs for hiring a professional?

- ENTER amount here, then SELECT unit of time on next screen (Month, Year)

→ GO TO F88

F87PER. The amount entered is: [F87] per __

- SELECT the unit of time below

7. Other-specify (F87PERSPEC.
Please specify. (String 100))

F87A. Would it amount to \$400 or more?

→ GO TO F88

↓ ↓

F87B. \$1000 or more? F87C. \$100 or more?

Household Furnishings

F88. (How much did you [and your family living there] spend altogether in [PYEAR]...)

On household furnishings and equipment, including household textiles, furniture, floor coverings, major appliances, small appliances and miscellaneous housewares?

- ENTER amount here, then SELECT unit of time on next screen (Month, Year)

→ GO TO F89

F88PER. The amount entered is: [F88] per __

- SELECT the unit of time below

7. Other-specify (F88PERSPEC.
Please specify. (String 100))

F88A. Would it amount to \$500 or more?

→ GO TO F89

↓ ↓

F88B. \$1500 or more? F88C. \$100 or more?

Clothing

F89. (How much did you [and your family living there] spend altogether in [PYEAR]...)

On clothing and apparel, including footwear, outerwear, and products such as watches or jewelry?

- ENTER amount here, then SELECT unit of time on next screen (Month, Year)

→ GO TO F90

F89PER. The amount entered is: [F89] per __

- SELECT the unit of time below

7. Other-specify (F89PERSPEC.
Please specify. (String 100))

F89A. Would it amount to \$700 or more?

→ GO TO F90

↓ ↓

F89B. \$1500 or more? F89C. \$200 or more?

Vacations

F90. (How much did you [and your family living there] spend altogether in [PYEAR]...)

On trips and vacations, including transportation, accommodations, and recreational expenses on trips?

- ENTER amount here, then SELECT unit of time on next screen (Month, Year)

\$ 0 → GO TO F91	\$ 1 – 999,997	DK/RF
↓		
<p>F90PER. The amount entered is: [F90] per __</p> <ul style="list-style-type: none"> • SELECT the unit of time below <div style="display: flex; justify-content: space-around;"> 5. Month 6. Year </div> <div style="border: 1px solid black; padding: 5px; margin-top: 5px;"> <p>7. Other-specify (F90PERSPEC. Please specify. (String 100))</p> </div>	<p>F90A. Would it amount to \$500 or more?</p> <div style="display: flex; justify-content: space-around;"> 1. Yes 5. No DK/RF → GO TO F91 </div> <div style="text-align: center; margin-top: 5px;">↓</div> <div style="display: flex; justify-content: space-around;"> <p>F90B. \$1500 or more?</p> <p>F90C. \$200 or more?</p> </div> <div style="display: flex; justify-content: space-around; margin-top: 5px;"> <div style="display: flex; gap: 10px;"> 1. Yes 5. No </div> <div style="display: flex; gap: 10px;"> 1. Yes 5. No </div> </div>	

Entertainment

F91. (How much did you [and your family living there] spend altogether in [PYEAR]...)

On recreation and entertainment, including tickets to movies, sporting events, and performing arts and hobbies including exercise, bicycles, trailers, camping, photography, and reading materials? [F90<>0: Do not include costs associated with the trips and vacations you mentioned previously.]

- ENTER amount here, then SELECT unit of time on next screen (Month, Year)

\$ 0 → GO TO SECTION G	\$ 1 – 999,997	DK/RF
↓		
<p>F91PER. The amount entered is: [F91] per __</p> <ul style="list-style-type: none"> • SELECT the unit of time below <div style="display: flex; justify-content: space-around;"> 5. Month 6. Year </div> <div style="border: 1px solid black; padding: 5px; margin-top: 5px;"> <p>7. Other-specify (F91PERSPEC. Please specify. (String 100))</p> </div> <p style="text-align: center; margin-top: 10px;">GO TO SECTION G</p>	<p>F91A. Would it amount to \$500 or more?</p> <div style="display: flex; justify-content: space-around;"> 1. Yes 5. No DK/RF → GO TO SECTION G </div> <div style="text-align: center; margin-top: 5px;">↓</div> <div style="display: flex; justify-content: space-around;"> <p>F91B. \$1500 or more?</p> <p>F91C. \$200 or more?</p> </div> <div style="display: flex; justify-content: space-around; margin-top: 5px;"> <div style="display: flex; gap: 10px;"> 1. Yes 5. No </div> <div style="display: flex; gap: 10px;"> 1. Yes 5. No </div> </div> <p style="text-align: center; margin-top: 10px;">GO TO SECTION G</p>	

END SECTION_F

Section G: Income; OFUM Education

[TOC](#)

SECTION_G

G1. Now I have some questions about finances and income.

- [ENTER \[1\] to continue](#)

2018/2019 Government Shutdown

GSD1. The next few questions are about the shutdown of the U.S. federal government that started in December 2018. Were you [[>1 FU MEMBER](#): or someone in your family living there] **financially affected** by the shutdown?

→ GO TO G1A

↓

GSD2 Rule: Number of FU Members

<input type="text" value="More Than One FU Member"/>	<input type="text" value="Only One FU Member"/>	→ Assign GSD2=AQSN of FU Member; Then GO TO GSD3
↓		

GSD2. Who was financially affected by the federal government shutdown?

- [ENTER all that apply](#)
- [PROBE](#): Any others?

AQSN list of FU Members if FU, FUMI, INST

GSD3. Were you [[>1 FU MEMBER](#): or someone in your family living there] furloughed (because of the shutdown)?

GSD4. Because of the shutdown, did you [[>1 FU MEMBER](#): or anyone in your family living there] miss any paychecks or receive paychecks for zero dollars, even if retroactive pay is eventually received?

GSD5. (Because of the shutdown,) did you [[>1 FU MEMBER](#): or anyone in your family living there] lose any earnings, after any retroactive pay was received?

→ GO TO GSD7

↓

GSD6. How much was that altogether?

- [[>1 FU MEMBER](#): [If needed](#): This amount should be the total lost earnings for everyone in your family]
- [ENTER amount here, then SELECT unit of time on next screen \(Week, Two weeks, Month, Year\)](#)

→ GO TO GSD7

↓

GSD6PER. The amount entered is: [GSD6] per _____

- SELECT the unit of time below

3. Week	4. Two weeks	5. Month	6. Year
7. Other-specify (GSD6PERSPEC. Specify. (String 100))			

GSD7. How did [1 FU MEMBER: you / >1 FU MEMBER: your family] manage any financial difficulties due to the shutdown - did you cut back on spending?

1. Yes	5. No
--------	-------

GSD8. (How did [1 FU MEMBER: you / >1 FU MEMBER: your family] manage any financial difficulties (due to the shutdown) – did you...)

Use savings in your bank or credit union savings account?

1. Yes	5. No
--------	-------

GSD9. (How did [1 FU MEMBER: you / >1 FU MEMBER: your family] manage any financial difficulties (due to the shutdown) – did you...)

Put off paying the rent or mortgage?

- ENTER [5] if R says “No rent or mortgage”

1. Yes	5. No
--------	-------

GSD10. (How did [1 FU MEMBER: you / >1 FU MEMBER: your family] manage any financial difficulties (due to the shutdown) – did you...)

Put off paying any other bills?

1. Yes	5. No
--------	-------

GSD11. (How did [1 FU MEMBER: you / >1 FU MEMBER: your family] manage any financial difficulties (due to the shutdown) – did you...)

Use your credit card more than you usually would?

1. Yes	5. No
--------	-------

GSD12. (How did [1 FU MEMBER: you / >1 FU MEMBER: your family] manage any financial difficulties (due to the shutdown) – did you...)

Use money from your retirement savings?

1. Yes	5. No
--------	-------

GSD13. (How did [1 FU MEMBER: you / >1 FU MEMBER: your family] manage any financial difficulties (due to the shutdown) – did you...)

Sell your belongings?

1. Yes	5. No
--------	-------

GSD14. (How did [1 FU MEMBER: you / >1 FU MEMBER: your family] manage any financial difficulties (due to the shutdown) – did you...)

Get a second job?

1. Yes	5. No
--------	-------

GSD15. (How did [*1 FU MEMBER: you / >1 FU MEMBER: your family*] manage any financial difficulties (due to the shutdown) – did you...)

File for unemployment insurance?

1. Yes 5. No

GSD16. (How did [*1 FU MEMBER: you / >1 FU MEMBER: your family*] manage any financial difficulties (due to the shutdown) – did you...)

Use a food bank or other emergency community support?

1. Yes 5. No

GSD17. (How did [*1 FU MEMBER: you / >1 FU MEMBER: your family*] manage any financial difficulties (due to the shutdown) – did you...)

Do something else?

1. Yes 5. No → GO TO G1A



GSD17SPEC. Please specify.

PYear Farm Income

G1A. CAI Checkpoint: Whether Reference Person or Spouse/Partner is a Farmer or Rancher on Current Main Job

<input type="checkbox"/> Farmer/Rancher (JOBTYPE=CMJ & BC28=Yes)	<input type="checkbox"/> 5. All Others	→ GO TO G5
<input type="checkbox"/> 1. RP Only	<input type="checkbox"/> 2. SP Only	<input type="checkbox"/> 3. Both

↓

G2. What were [*R=RP: [your / your (and [SP]'s) / R=SP [your / your (and [RP]'s) / R=OFUM, Proxy: [RP / SP]'s / [RP]'s and [SP]'s*] total receipts from farming in [PYEAR], including soil bank payments and commodity credit loans?

G3. What were [[*your / your (and [SP]'s) / [your / your (and [RP]'s) / [RP / SP]'s / [RP]'s and [SP]'s*] total operating expenses, not counting living expenses?

G4CKPT. CAI Checkpoint: Whether G2 or G3 is Non-Response

<input type="checkbox"/> 1. G2=DK, RF or G3=DK, RF	<input type="checkbox"/> 5. All Others	→ Assign G4=G2 minus G3; Then GO TO G5
--	--	--

↓

G4. (And) what was the net income from farming?

- Receipts: [Don't Know / Refused / \$[G2]]
- Expenses: [Don't Know / Refused / \$[G3]]

PYear Businesses

G5. Did [you / [RP]] [or anyone else in the family there] own a business at any time in [PYEAR] or have a financial interest in any business enterprise?

1. Yes 5. No → GO TO G12



G6. How many businesses or financial interests did you have in [PYEAR]?

1. One → GO TO G7A 2. Two 3. Three 4. Four 5. Five DK/RF → GO TO G12



SECTION_G.G7_G11 [1-5] [1-5]=Which business

G7. [LOOP 1: I'll be asking this next series of questions about each business separately. We can begin with whichever business you choose. / ALL OTHERS: And now some questions about the next business.]

- ENTER [1] to continue

1. Continue

G7A. Business #[1-5]

What kind of business was that?

String 500

G7B. Business #[1-5]

What was the name of (the/that) business?

- IF necessary: This information will help us to process employment information you gave us. The name itself will never be released as part of data from the study.
- IWER: IF no employer name is given by R, ask for job title or anything that can help identify the job.

String 25

G8. Business #[1-5]: [G7B]

Who in the family owned that business?

- ENTER all that apply
- PROBE: Any others?

1 – 24. [CYNAMF CYNAML], [CYAQRTH], [CYFUHU] AQSN list of FU Members if FU, FUMI≤PY, MO≥PY, DEC> PY, MILIT, EDUC, HLTH, OTHR

97. Owner not on family list (G8SPEC. Who was that? (String 100))

SECTION_G.G7_G11 [1-5].G9_G10 [1-2] [1-5]=Which business; [1]=Current RP, [2]=Current SP

G9AQSN. AQSN of Current Reference Person (Spouse/Partner)

G9A. Business #[1-5]: [G7B] - [CYNAMF CYNAML]: [CYAQRTH], [CYFUHU], Age [AGEIWDATE] [(Respondent)]

Did [you / [RP / SP]] put in any work time for this business in [PYEAR]?

- PROBE if inconsistent with employment section

1. Yes 5. No → GO TO G9BB RULE



G9B. Business #[1-5]: [G7B] - [CYNAMF CYNAML]: [CYAQRTH], [CYFUHU], Age [AGEIWDATE] [(Respondent)]

Did you tell me about this work earlier?

[READ employers if needed](#)

[\[List of PYEAR Employers from EHC\]](#)

1. Yes, these work hours were reported

→ GO TO G9 RULE

5. No, these work hours were not reported



G9J1H. Business #[1-5]: [G7B] - [CYNAMF CYNAML]: [CYAQRTH], [CYFUHU], Age [AGEIWDATE]

[(Respondent)]

Then I would like to ask you some questions now about this business and [your / [RP / SP]'s] work in it.

- ENTER [1] to continue

1. Continue

G9J3H. Business #[1-5]: [G7B] - [CYNAMF CYNAML]: [CYAQRTH], [CYFUHU], Age [AGEIWDATE]

[(Respondent)]

What sort of work did [you / he / she] do?

- DO NOT PROBE

String 500

G9J3AH. Business #[1-5]: [G7B] - [CYNAMF CYNAML]: [CYAQRTH], [CYFUHU], Age [AGEIWDATE]

[(Respondent)]

What was the official title of [your / [RP / SP]'s] job? (The title that the business used.)

- DO NOT PROBE

String 200

G9J4H. Business #[1-5]: [G7B] - [CYNAMF CYNAML]: [CYAQRTH], [CYFUHU], Age [AGEIWDATE]

[(Respondent)]

And, how many weeks did [you / he / she] work at this business in [PYEAR]?

1 – 52

G9J5H. Business #[1-5]: [G7B] - [CYNAMF CYNAML]: [CYAQRTH], [CYFUHU], Age [AGEIWDATE]

[(Respondent)]

On average, how many hours a week did [you / he / she] work at this business in [PYEAR]?

- ROUND DOWN for fractions less than ½ (0.5)
- ROUND UP for fractions ½ (0.5) or more

1 – 112

G9J6HMO. Business #[1-5]: [G7B] - [CYNAMF CYNAML]: [CYAQRTH], [CYFUHU], Age [AGEIWDATE]

[(Respondent)]

In what month and year did [you / he / she] start working at this business?

- SELECT Month and [Enter] to go to next screen for year
- IF NECESSARY: What would be your best estimate?

1. January	2. February	3. March	4. April	5. May	
6. June	7. July	8. August	9. September	10. October	
11. November	12. December	21. Winter	22. Spring	23. Summer	24. Fall

G9J6HYR. Business #[1-5]: [G7B] - [CYNAMF CYNAML]: [CYAQRTH], [CYFUHU], Age [AGEIWDAT] [(Respondent)]

- The month entered is: [9J6HMO]
- ENTER the year below
1901- [PYEAR] Actual year
9997 Before [P2YEAR], DK exact year

[1901 -- [PYEAR]] [9997. Before [P2YEAR], DK Exact Year]

G9J7H. Business #[1-5]: [G7B] - [CYNAMF CYNAML]: [CYAQRTH], [CYFUHU], Age [AGEIWDAT] [(Respondent)]

In which months during [PYEAR] [were you / was [he / she]] working at this business?

- ENTER all that apply
- PROBE: Any others?

1. January	2. February	3. March	4. April	5. May
6. June	7. July	8. August	9. September	10. October
11. November	12. December	13. All		

G9J8H. Business #[1-5]: [G7B] - [CYNAMF CYNAML]: [CYAQRTH], [CYFUHU], Age [AGEIWDAT] [(Respondent)]

[Have you / Has [he / she]] stopped working at this business?

1. Yes 5. No → GO TO G9 RULE



G9J9HMO. Business #[1-5]: [G7B] - [CYNAMF CYNAML]: [CYAQRTH], [CYFUHU], Age [AGEIWDAT] [(Respondent)]

In what month and year was that?

- SELECT Month and [Enter] to go to next screen for year
- IF NECESSARY: What would be your best estimate?

1. January	2. February	3. March	4. April
5. May	6. June	7. July	8. August
9. September	10. October	11. November	12. December
21. Winter	22. Spring	23. Summer	24. Fall

G9J9HYR. Business #[1-5]: [G7B] - [CYNAMF CYNAML]: [CYAQRTH], [CYFUHU], Age [AGEIWDAT] [(Respondent)]

The month entered is: [G9J9HMO]

- ENTER the year below
9996 [PYEAR] or [CYEAR] and DK which

[PYEAR] [CYEAR] 9996. [PYEAR] - [CYEAR], DK Which Year

G9J10H. Business #[1-5]: [G7B] - [CYNAMF CYNAML]: [CYAQRTH], [CYFUHU], Age [AGEIWDAT] [(Respondent)]

What happened - did it go out of business, did [you / he / she] quit, or what?

String 500

G9 RULE: Whether Spouse/Partner in FU

Spouse/Partner (CYAQRTH=201-222, CYFUHU=FU, FUMI)	→ Repeat G9_G10; Then GO TO G10	No Spouse/Partner ↓
---	------------------------------------	------------------------

END G9_G10

G10. Business #[1-5]: [G7B] - [CYNAMF CYNAML]: [CYAQRTH], [CYFUHU], Age [AGEIWDATE] [(Respondent)]
(Please remind me,) was it a corporation or an unincorporated business?

1. Corporation	2. Unincorporated	7. Other-specify (G10SPEC. Specify (String 100))	DK/RF
----------------	-------------------	--	-------

GO TO G11D_G11E



G11. Business #[1-5]: [G7B] - [CYNAMF CYNAML]: [CYAQRTH], [CYFUHU], Age [AGEIWDATE] [(Respondent)]
What were the total receipts from the business in [PYEAR]?

\$ 0 – 9,999,997

G11A. Business #[1-5]: [G7B] - [CYNAMF CYNAML]: [CYAQRTH], [CYFUHU], Age [AGEIWDATE] [(Respondent)]

What were the total operating expenses, not counting living expenses (in [PYEAR])?

\$ 0 – 9,999,997

G11CKPT. CAI Checkpoint: Whether G11 or G11A is Non-Response

1. G11=DK, RF or G11A=DK, RF	5. All Others	→ Assign G11B=G11 minus G11A; Then GO TO G12 RULE
------------------------------	---------------	--

↓

G11B. Business #[1-5]: [G7B] - [CYNAMF CYNAML]: [CYAQRTH], [CYFUHU], Age [AGEIWDATE] [(Respondent)]

(And) what was the net income from the business (in [PYEAR])?

- Receipts: [Don't Know / Refused / \$[G11]]
- Expenses: [Don't Know / Refused / \$[G11A]]

\$ -999,999 – 9,999,997

GO TO G12 RULE

SECTION_G.G7_G11 [1-5].G11D_G11E [1-2] [1-5]=Which business; [1]=Current RP, [2]=Current SP

G11DAQSN. AQSN of Current Reference Person (Spouse/Partner)

G11DCKPT. CAI Checkpoint: Whether Worked For This Corp But Did Not Report It

1. Worked For Corp But Didn't Report It (G9A=Yes & G9B<>Yes)	5. All Others	→ GO TO G11E RULE
--	---------------	-------------------

↓

G11D. Business #[1-5]: [G7B] - [CYNAMF CYNAML]: [CYAQRTH], [CYFUHU], Age [AGEIWDATE] [(Respondent)]
How much did [you / RP / SP] make at this business in [PYEAR]?

\$ 1 – 9,999,997

G11E RULE: Whether Spouse/Partner in FU

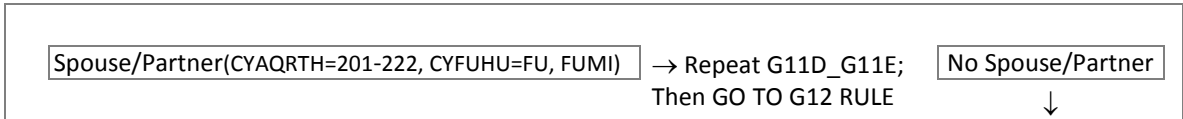

END G11D_G11E

G12 RULE: Number of Businesses at G6

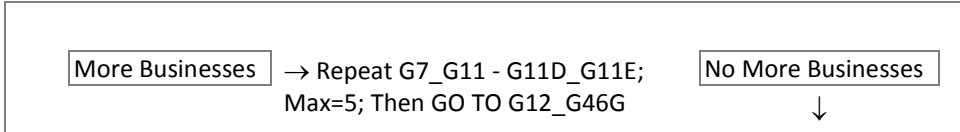

END G7_G11

PYear Income - Reference Person and Spouse/Partner

SECTION_G.G12_G46G [1-2] [1]=Current Reference Person, [2]=Current Spouse/Partner

G12A QSN. A QSN of Current Reference Person (Spouse/Partner)

Earnings from Work

G12. [CYNAMF CYNAML]: [CYAQRTH], [CYFUHU], Age [AGEIWDATE] [(Respondent)]

Did [you / [RP / SP]] earn wages or salaries in [PYEAR] from working on any jobs [G9A=YES & G10=UNINCORPORATED: besides the unincorporated business we have just talked about]?

(Including the jobs we already talked about)

[READ Employers Worked for in \[PYEAR\]:](#)
[\[List of PYEAR Employers from EHC\]](#)

- IF necessary, review employment history and add: including wages or salaries from the job(s) we already talked about?

→ GO TO G13



G12CKPT2/G12CKPT2S. CAI Checkpoint: Whether Job Reported for PYEAR, or No Job Reported but Worked For a Reported Incorporated Business

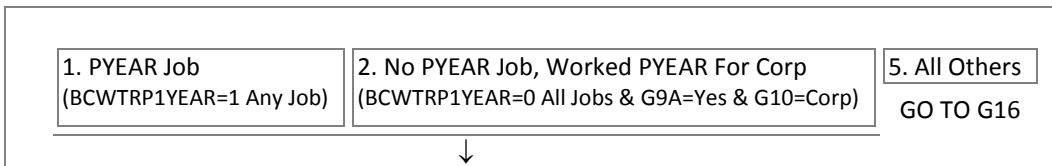

G12 CHECK: [Reference Person / Spouse/Partner] either reported a [PYEAR] job in the EHC, or reported working for an incorporated business in [PYEAR], but reported NO wages or salary at G12.

- If the [PYEAR] job is THE SAME as work reported in [PYEAR] for an UNincorporated business, DO NOT PROBE - SELECT [Suppress] and enter this information in G12A.
- Otherwise, PROBE: (Were/Was) there any wage(s) or salary(s) from (this job/these jobs)?
- If "YES", PRESS [Enter] or SELECT [Go To], to go to G12 & ENTER [Yes]
- If "NO", SELECT [Suppress] to go to G12A & record explanation.

→ RETURN TO G12



G12A. [CYNAMF CYNAML]: [CYAQRTH], [CYFUHU], Age [AGEIWDATE] [(Respondent)]
 How is it that [you / [RP / SP]] worked in [PYEAR], but did not receive earnings from it?
 → GO TO G16

G13. [CYNAMF CYNAML]: [CYAQRTH], [CYFUHU], Age [AGEIWDATE] [(Respondent)]
 How much did [you / [RP / SP]] earn altogether from wages or salaries in [PYEAR], that is, before anything was deducted for taxes or other things?

G14. [CYNAMF CYNAML]: [CYAQRTH], [CYFUHU], Age [AGEIWDATE] [(Respondent)]
 In addition to this, did [you / [RP / SP]] have any income from bonuses, overtime, tips, or commissions?
 → GO TO G16A → GO TO G17F

G16. [CYNAMF CYNAML]: [CYAQRTH], [CYFUHU], Age [AGEIWDATE] [(Respondent)]
 Did [you / [RP / SP]] have any income from bonuses, overtime, tips, or commissions?
 → GO TO G18A

↓

G16A. [CYNAMF CYNAML]: [CYAQRTH], [CYFUHU], Age [AGEIWDATE] [(Respondent)]
 Which was that?

- ENTER all that apply
- PROBE: Any others?

1. Bonuses	2. Overtime	3. Tips	4. Commissions	7. Other-specify	DK/RF
ASK G17A	ASK G17B	ASK G17C	ASK G17D	ASK G16B, G17E	GO TO G17F

G17A. [CYNAMF CYNAML]: [CYAQRTH], [CYFUHU], Age [AGEIWDATE] [(Respondent)]
 How much was from bonuses?

G17B. [CYNAMF CYNAML]: [CYAQRTH], [CYFUHU], Age [AGEIWDATE] [(Respondent)]
 How much was from overtime?

G17C. [CYNAMF CYNAML]: [CYAQRTH], [CYFUHU], Age [AGEIWDATE] [(Respondent)]
 How much was from tips?

G17D. [CYNAMF CYNAML]: [CYAQRTH], [CYFUHU], Age [AGEIWDATE] [(Respondent)]
 How much was from commissions?

G16B. [CYNAMF CYNAML]: [CYAQRTH], [CYFUHU], Age [AGEIWDATE] [(Respondent)]
 What was that other job-related income from?

G17E. [CYNAMF CYNAML]: [CYAQRTH], [CYFUHU], Age [AGEIWDATE] [(Respondent)]
 How much was from other job related income?

- G17F. [CYNAMF CYNAML]: [CYAQRTH], [CYFUHU], Age [AGEIWDATE] [(Respondent)]
 Reported Incomes: [Wages/salaries, bonus, overtime, tips, commissions, other job-related income]
 Did you tell me earlier about all the jobs that go with (this / these) income(s)?
 (Including the jobs we already talked about)
[READ employers if needed](#)
[\[List of PYEAR Employers from EHC\]](#)

1. Yes, R reported all jobs that produced this income	→ GO TO G18A	5. No, R did not report all jobs that produced this income
---	--------------	--



- G17J1. [CYNAMF CYNAML]: [CYAQRTH], [CYFUHU], Age [AGEIWDATE] [(Respondent)]
 Then I would like to ask you some questions now about the work [you / [RP / SP]] did for this income. Did [you / he / she] work for the government or a private company?
- **If R says Government, PROBE:** Is that the federal, state, or local government?

1. Federal government	2. State government	3. Local government
4. Private non-government	5. Self-employed	7. Other-specify (G17J1SPEC. Specify (String 100))

- G17J2. [CYNAMF CYNAML]: [CYAQRTH], [CYFUHU], Age [AGEIWDATE] [(Respondent)]
 What was the name of that employer?
- **IF necessary:** This information will help us to process employment information you gave us. The name itself will never be released as part of data from the study.
 - **IWER:** IF no employer name is given by R, ask for job title or anything that can help identify the job.

String 25

- G17J3. [CYNAMF CYNAML]: [CYAQRTH], [CYFUHU], Age [AGEIWDATE] [(Respondent)]
 What sort of work did [you / he / she] do?
- **DO NOT PROBE**

String 500

- G17J3B. [CYNAMF CYNAML]: [CYAQRTH], [CYFUHU], Age [AGEIWDATE] [(Respondent)]
 What kind of business or industry was that in?
- **DO NOT PROBE**

String 500

- G17J3C. [CYNAMF CYNAML]: [CYAQRTH], [CYFUHU], Age [AGEIWDATE] [(Respondent)]
 What was the official title of [your / [RP / SP]]'s job? (The title that [your / his / her] employer used.)
- **DO NOT PROBE**

String 200

- G17J4. [CYNAMF CYNAML]: [CYAQRTH], [CYFUHU], Age [AGEIWDATE] [(Respondent)]
 And, how many weeks did [you / he / she] work at this in [PYEAR]?

1 – 52

G17J5. [CYNAMF CYNAML]: [CYAQRTH], [CYFUHU], Age [AGEIWDATE] [(Respondent)]

On average, how many hours a week did [you / he / she] work in [PYEAR]?

- ROUND DOWN for fractions less than ½ (0.5)
- ROUND UP for fractions ½ (0.5) or more

1 – 112

G17J6MO. [CYNAMF CYNAML]: [CYAQRTH], [CYFUHU], Age [AGEIWDATE] [(Respondent)]

In what month and year did [you / he / she] start this work?

- SELECT Month and [Enter] to go to next screen for year
- IF NECESSARY: What would be your best estimate?

1. January	2. February	3. March	4. April	5. May	6. June
7. July	8. August	9. September	10. October	11. November	12. December
21. Winter	22. Spring	23. Summer	24. Fall		

G17J6YR. [CYNAMF CYNAML]: [CYAQRTH], [CYFUHU], Age [AGEIWDATE] [(Respondent)]

The month entered is: [G17J6MO]

- ENTER the year below
- 9997 Before [P2YEAR], DK exact year

1901 – [PYEAR] 9997. Before [P2YEAR], DK Exact Year

G17J7. [CYNAMF CYNAML]: [CYAQRTH], [CYFUHU], Age [AGEIWDATE] [(Respondent)]

In which months during [PYEAR] [were you / was [he / she]] working at it?

- ENTER all that apply
- PROBE: Any others?

1. January	2. February	3. March	4. April	5. May	6. June
7. July	8. August	9. September	10. October	11. November	12. December
13. All					

G17J8. [CYNAMF CYNAML]: [CYAQRTH], [CYFUHU], Age [AGEIWDATE] [(Respondent)]

[Have you / Has [he / she]] stopped this work?

1. Yes 5. No → GO TO G18A



G17J9MO. [CYNAMF CYNAML]: [CYAQRTH], [CYFUHU], Age [AGEIWDATE] [(Respondent)]

In what month and year was that?

- SELECT Month and [Enter] to go to next screen for year
- IF NECESSARY: What would be your best estimate?

1. January	2. February	3. March	4. April	5. May	
6. June	7. July	8. August	9. September	10. October	
11. November	12. December	21. Winter	22. Spring	23. Summer	24. Fall

G17J9YR. [CYNAMF CYNAML]: [CYAQRTH], [CYFUHU], Age [AGEIWDATE] [(Respondent)]

The month entered is: [G17J9MO]

- ENTER the year below
- 9996 [PYEAR] or [CYEAR] and DK which

[PYEAR] [CYEAR] 9996. [PYEAR] – [CYEAR], DK Which Year

G17J10. [CYNAMF CYNAML]: [CYAQRTH], [CYFUHU], Age [AGEIWDATE] [(Respondent)]

What happened - did [your / his / her] employer close or go out of business, did [you / he / she] quit, or what?

String 500

Professional Practice or Trade

G18A. [CYNAMF CYNAML]: [CYAQRTH], [CYFUHU], Age [AGEIWDATE] [(Respondent)]

I'm going to read you a list of other sources of income [you / [RP / SP]] might have had. Did [you / [RP / SP]] receive any other income in [PYEAR] from professional practice or trade?

1. Yes 5. No → GO TO G22CKPT

↓

G19A. [CYNAMF CYNAML]: [CYAQRTH], [CYFUHU], Age [AGEIWDATE] [(Respondent)]

How much was it?

- ENTER amount here, then SELECT unit of time on next screen (Day, Week, Two weeks, Month, Year)

\$ 1 – 9,999,997 DK/RF → GO TO G20A

↓

G19APER. The amount entered is: [G19A] per ____

- SELECT the unit of time below

2. Day 3. Week 4. Two weeks 5. Month 6. Year

7. Other-specify (G19APERSPEC. Specify. (String 100))

G20A. [CYNAMF CYNAML]: [CYAQRTH], [CYFUHU], Age [AGEIWDATE] [(Respondent)]

During which months of [PYEAR] did [you / he / she] get this income?

- ENTER all that apply
- PROBE: Any others?

1. January 2. February 3. March 4. April 5. May 6. June
7. July 8. August 9. September 10. October 11. November 12. December 13. All

G21ACKPT. [CYNAMF CYNAML]: [CYAQRTH], [CYFUHU], Age [AGEIWDATE] [(Respondent)]

Reported Incomes: Professional Practice or Trade

Did you tell me earlier about all the jobs that go with this income?

(Including the jobs we already talked about)

READ employers if needed

[List of PYEAR Employers from EHC]

1. Yes, R reported all jobs that produced this income → GO TO G22CKPT 5. No, R did not report all jobs that produced this income

↓

G18AJ1. [CYNAMF CYNAML]: [CYAQRTH], [CYFUHU], Age [AGEIWDATE] [(Respondent)]

Then I would like to ask you some questions now about the work [you / he / she] did for this income. Did [you / he / she] work for the government or a private company?

- If R says Government, PROBE: Is that the federal, state, or local government?

1. Federal government 2. State government 3. Local government

4. Private non-government 5. Self-employed 7. Other-specify (G18AJ1SPEC. Specify (String 100))

G18AJ2. [CYNAMF CYNAML]: [CYAQRTH], [CYFUHU], Age [AGEIWDATE] [(Respondent)]

What was the name of that employer?

- IF NECESSARY: This information will help us to process employment information you gave us. The name itself will never be released as part of data from the study.
- IWER: IF no employer name is given by R, ask for job title or anything that can help identify the job.

String 25

G18AJ3. [CYNAMF CYNAML]: [CYAQRTH], [CYFUHU], Age [AGEIWDATE] [(Respondent)]

What sort of work did [you / he / she] do?

- DO NOT PROBE

String 500

G18AJ3B. [CYNAMF CYNAML]: [CYAQRTH], [CYFUHU], Age [AGEIWDATE] [(Respondent)]

What kind of business or industry was that in?

- DO NOT PROBE

String 500

G18AJ3C. [CYNAMF CYNAML]: [CYAQRTH], [CYFUHU], Age [AGEIWDATE] [(Respondent)]

What was the official title of [your / [RP / SP]'s] job? (The title that [your / his / her] employer used.)

- DO NOT PROBE

String 200

G18AJ4. [CYNAMF CYNAML]: [CYAQRTH], [CYFUHU], Age [AGEIWDATE] [(Respondent)]

And, how many weeks did [you / he / she] work at this in [PYEAR]?

1 – 52

G18AJ5. [CYNAMF CYNAML]: [CYAQRTH], [CYFUHU], Age [AGEIWDATE] [(Respondent)]

On average, how many hours a week did [you / he / she] work in [PYEAR]?

- ROUND DOWN for fractions less than $\frac{1}{2}$ (0.5)
- ROUND UP for fractions $\frac{1}{2}$ (0.5) or more

1 – 112

G18AJ6MO. [CYNAMF CYNAML]: [CYAQRTH], [CYFUHU], Age [AGEIWDATE] [(Respondent)]

In what month and year did [you / he / she] start this work?

- SELECT Month and [Enter] to go to next screen for year
- IF NECESSARY: What would be your best estimate?

1. January	2. February	3. March	4. April	5. May	6. June
7. July	8. August	9. September	10. October	11. November	12. December
21. Winter	22. Spring	23. Summer	24. Fall		

G18AJ6YR. [CYNAMF CYNAML]: [CYAQRTH], [CYFUHU], Age [AGEIWDATE] [(Respondent)]

The month entered is: [G18AJ6MO]

- ENTER the year below
9997 Before [P2YEAR], DK exact year

1901 – [PYEAR] 9997. Before [P2YEAR], DK Exact Year

G18AJ7. [CYNAMF CYNAML]: [CYAQRTH], [CYFUHU], Age [AGEIWDATE] [(Respondent)]

In which months during [PYEAR] [were you / was [he / she]] working at it?

- ENTER all that apply
- PROBE: Any others?

1. January	2. February	3. March	4. April	5. May	6. June	
7. July	8. August	9. September	10. October	11. November	12. December	13. All

G18AJ8. [CYNAMF CYNAML]: [CYAQRTH], [CYFUHU], Age [AGEIWDATE] [(Respondent)]

[Have you / Has [he / she]] stopped this work?

1. Yes 5. No → GO TO G22CKPT



G18AJ9MO. [CYNAMF CYNAML]: [CYAQRTH], [CYFUHU], Age [AGEIWDATE] [(Respondent)]

In what month and year was that?

- SELECT Month and [Enter] to go to next screen for year
- IF NECESSARY: What would be your best estimate?

1. January	2. February	3. March	4. April	5. May	
6. June	7. July	8. August	9. September	10. October	
11. November	12. December	21. Winter	22. Spring	23. Summer	24. Fall

G18AJ9YR. [CYNAMF CYNAML]: [CYAQRTH], [CYFUHU], Age [AGEIWDATE] [(Respondent)]

The month entered is: [G18AJ9MO]

- ENTER the year below
9996 [PYEAR] or [CYEAR] and DK which

[PYEAR] [CYEAR] 9996. [PYEAR] – [CYEAR], DK Which Year

G18AJ10. [CYNAMF CYNAML]: [CYAQRTH], [CYFUHU], Age [AGEIWDATE] [(Respondent)]

What happened – did it go out of business, did [you / he / she] quit, or what?

String 500

Other Earnings

G22CKPT. CAI Checkpoint: Number of PYEAR Jobs Reported

1. More Than One Job in [PYEAR]	5. All Others	→ GO TO G25A
---------------------------------	---------------	--------------

↓

G23. [CYNAMF CYNAML]: [CYAQRTH], [CYFUHU], Age [AGEIWDATE] [(Respondent)]

Did you include [your / [RP / SP]'s] earnings from all of [your / his / her] jobs in the amounts we just talked about?

1. Yes → GO TO G25A 5. No



G24. [CYNAMF CYNAML]: [CYAQRTH], [CYFUHU], Age [AGEIWDATE] [(Respondent)]

How much did [you / [RP / SP]] earn from (that job/those other jobs) in [PYEAR]?

\$ 1 – 9,999,997

Rent

G25A. [CYNAMF CYNAML]: [CYAQRTH], [CYFUHU], Age [AGEIWDATE] [(Respondent)]

Did [you / [RP / SP]] receive any (other) income in [PYEAR] from rent?

1. Yes 5. No → GO TO G25B



G26A. [CYNAMF CYNAML]: [CYAQRTH], [CYFUHU], Age [AGEIWDATE] [(Respondent)]

How much was it?

- ENTER amount here, then SELECT unit of time on next screen (Week, Two weeks, Month, Year)

\$ 1 – 999,997 DK/RF → GO TO G26A1CKPT



G26APER. The amount entered is: [G26A] per _____

- SELECT the unit of time below

3. Week 4. Two weeks 5. Month 6. Year
7. Other-specify (G26APERSPEC. Specify. (String 100))

G26A1CKPT. CAI Checkpoint: Whether Spouse/Partner in FU

1. RP Loop: SP in FU (CYAQRTH=201-222, CYFUHU=FU, FUMI)	3. SP Loop	5. RP Loop: No SP
↓	GO TO G26A3CKPT	GO TO G27A

G26A2. [CYNAMF CYNAML]: [CYAQRTH], [CYFUHU], Age [AGEIWDATE] [(Respondent)]

Does that include [your / [SP]'s] share?

1. Yes 5. No

G26A3CKPT.CAI Checkpoint: Whether Reference Person Reported Rent

1. SP Loop: RP Rent (G25A[1]=Yes)	2. RP Loop	3. SP Loop: No RP Rent (G25A[1]<>Yes)
↓	GO TO G27A	

G26A3. [CYNAMF CYNAML]: [CYAQRTH], [CYFUHU], Age [AGEIWDATE] [(Respondent)]

Is that in addition to the amount you reported for [[RP] / yourself]?

1. Yes 5. No

G27A. [CYNAMF CYNAML]: [CYAQRTH], [CYFUHU], Age [AGEIWDATE] [(Respondent)]

During which months of [PYEAR] did [you / [RP / SP]] get this income?

- ENTER all that apply
- PROBE: Any others?

1. January	2. February	3. March	4. April	5. May	6. June
7. July	8. August	9. September	10. October	11. November	12. December
					13. All

Dividends

G25B. [CYNAMF CYNAML]: [CYAQRTH], [CYFUHU], Age [AGEIWDATE] [(Respondent)]

(Did [you / [RP / SP]] receive any other income in [PYEAR]...)

From dividends?

1. Yes 5. No → GO TO G25C



G26B. [CYNAMF CYNAML]: [CYAQRTH], [CYFUHU], Age [AGEIWDATE] [(Respondent)]

How much was it?

- ENTER amount here, then SELECT unit of time on next screen (Month, Year)

\$ 1 – 999,997 DK/RF → GO TO G26B1CKPT



G26BPER. The amount entered is: [G26B] per _____

- SELECT the unit of time below

5. Month 6. Year 7. Other-specify (G26BPERSPEC. Specify. (String 100))

G26B1CKPT. CAI Checkpoint: Whether Spouse/Partner in FU

1. RP Loop: SP in FU (CYAQRTH=201-222, CYFUHU=FU, FUMI)	3. SP Loop	5. RP Loop: No SP
↓	GO TO G26B3CKPT	GO TO G27B

G26B2. [CYNAMF CYNAML]: [CYAQRTH], [CYFUHU], Age [AGEIWDATE] [(Respondent)]

Does that include [your / [SP]'s] dividends?

1. Yes 5. No

G26B3CKPT.CAI Checkpoint: Whether Reference Person Reported Dividends

1. SP Loop: RP Dividends (G25B[1]=Yes)	2. RP Loop	3 SP Loop: No RP Dividends (G25B[1]<>Yes)
↓	GO TO G27B	

G26B3. [CYNAMF CYNAML]: [CYAQRTH], [CYFUHU], Age [AGEIWDATE] [(Respondent)]

Is that in addition to the amount you reported for [[RP] / yourself]?

1. Yes 5. No

G27B. [CYNAMF CYNAML]: [CYAQRTH], [CYFUHU], Age [AGEIWDATE] [(Respondent)]

During which months of [PYEAR] did [you / [RP / SP]] get this income?

- ENTER all that apply

- PROBE: Any others?

1. January	2. February	3. March	4. April	5. May	6. June
7. July	8. August	9. September	10. October	11. November	12. December
					13. All

Interest

G25C. [CYNAMF CYNAML]: [CYAQRTH], [CYFUHU], Age [AGEIWDATE] [(Respondent)]

(Did [you / [RP / SP]] earn any other income in [PYEAR]...)

From interest?

1. Yes 5. No → GO TO G25D



G26C. [CYNAMF CYNAML]: [CYAQRTH], [CYFUHU], Age [AGEIWDATE] [(Respondent)]

How much was it?

- ENTER amount here, then SELECT unit of time on next screen (Week, Two weeks, Month, Year)

\$ 1 – 999,997 DK/RF → GO TO G26C1CKPT



G26CPER. The amount entered is: [G26C] per ____

- SELECT the unit of time below

3. Week 4. Two weeks 5. Month 6. Year

7. Other-specify (G26CPERSPEC. Specify. (String 100))

G26C1CKPT. CAI Checkpoint: Whether Spouse/Partner in FU

1. RP Loop: SP in FU (CYAQRTH=201-222, CYFUHU=FU, FUMI)

3. SP Loop

5. RP Loop: No SP



GO TO G26C3CKPT

GO TO G27C

G26C2. [CYNAMF CYNAML]: [CYAQRTH], [CYFUHU], Age [AGEIWDATE] [(Respondent)]

Does that include [your / [SP]'s] interest?

1. Yes 5. No

G26C3CKPT. CAI Checkpoint: Whether Reference Person Reported Interest

1. SP Loop: RP Interest (G25C[1]=Yes)

2. RP Loop

3. SP Loop: No RP Interest (G25C[1]<>Yes)



GO TO G27C

G26C3. [CYNAMF CYNAML]: [CYAQRTH], [CYFUHU], Age [AGEIWDATE] [(Respondent)]

Is that in addition to the amount you reported for [[RP] / yourself]?

1. Yes 5. No

G27C. [CYNAMF CYNAML]: [CYAQRTH], [CYFUHU], Age [AGEIWDATE] [(Respondent)]

During which months of [PYEAR] did [you / [RP / SP]] get this income?

- ENTER all that apply

- PROBE: Any others?

1. January	2. February	3. March	4. April	5. May	6. June	
7. July	8. August	9. September	10. October	11. November	12. December	13. All

Trust Funds and Royalties

G25D. [CYNAMF CYNAML]: [CYAQRTH], [CYFUHU], Age [AGEIWDATE] [(Respondent)]

(Did [you / [RP / SP]] receive any other income in [PYEAR]...)

From trust funds and royalties?

1. Yes 5. No → GO TO G25ECKPT



G26D. [CYNAMF CYNAML]: [CYAQRTH], [CYFUHU], Age [AGEIWDATE] [(Respondent)]

How much was it?

- ENTER amount here, then SELECT unit of time on next screen (Month, Year)

\$ 1 – 999,997 DK/RF → GO TO G27D



G26DPER. The amount entered is: [G26D] per ____

- SELECT the unit of time below

5. Month 6. Year 7. Other-specify (G26DPERSPEC. Specify. (String 100))

G27D. [CYNAMF CYNAML]: [CYAQRTH], [CYFUHU], Age [AGEIWDATE] [(Respondent)]

During which months of [PYEAR] did [you / [RP / SP]] get this income?

- ENTER all that apply
- PROBE: Any others?

1. January	2. February	3. March	4. April	5. May	6. June	
7. July	8. August	9. September	10. October	11. November	12. December	13. All

Temporary Assistance for Needy Families (TANF)

G25ECKPT. CAI Checkpoint: PYEAR Wages/Salary

1. PYEAR Wages/Salary \$25,000 or Less (G13 ≤ \$25,000, DK/RF) 5. All Others → GO TO G31CKPT



G25E. [CYNAMF CYNAML]: [CYAQRTH], [CYFUHU], Age [AGEIWDATE] [(Respondent)]

(Did [you / [RP / SP]] receive any income in [PYEAR]...)

From TANF (Temporary Assistance for Needy Families) [PYSTATERESIDE<>FC/DK/RF: or [STATEPROG]]?

1. Yes 5. No → GO TO G25F



G26E. [CYNAMF CYNAML]: [CYAQRTH], [CYFUHU], Age [AGEIWDATE] [(Respondent)]

How much was it?

- ENTER amount here, then SELECT unit of time on next screen (Two weeks, Month, Year)

\$ 1 – 999,997 DK/RF → GO TO G27E



G26EPPER. The amount entered is: [G26E] per ____

- SELECT the unit of time below

4. Two weeks 5. Month 6. Year 7. Other-specify (G26EPPERPEC. Specify. (String 100))

G27E. [CYNAMF CYNAML]: [CYAQRTH], [CYFUHU], Age [AGEIWDATE] [(Respondent)]

During which months of [PYEAR] did [you / [RP / SP]] get this income?

- ENTER all that apply
- PROBE: Any others?

1. January	2. February	3. March	4. April	5. May	6. June	
7. July	8. August	9. September	10. October	11. November	12. December	13. All

G27EE. [CYNAMF CYNAML]: [CYAQRTH], [CYFUHU], Age [AGEIWDATE] [(Respondent)]

Who in the family was covered by this?

- ENTER all that apply
- PROBE: Any others?

1 – 24. [CYNAMF CYNAML], [CYAQRTH], [CYFUHU] AQSN list of FU Members if FU, FUMI≤PY, MO≥PY, DEC≥PY, MIL, EDUC, HLTH, OTHR

Supplemental Security Income (SSI)

G25F. [CYNAMF CYNAML]: [CYAQRTH], [CYFUHU], Age [AGEIWDATE] [(Respondent)]

(Did [you / [RP / SP]] receive any income in [PYEAR]...)

From Supplemental Security Income?

- SSI (Supplemental Security Income) is **not** Social Security, nor is it Social Security Disability Insurance (SSDI), although the Social Security Administration administers the program and a person can receive both. See F1-Help for more information.

1. Yes 5. No → GO TO G25G



G25FF. [CYNAMF CYNAML]: [CYAQRTH], [CYFUHU], Age [AGEIWDATE] [(Respondent)]

Did [you / [RP / SP]] receive it for [yourself / himself / herself], or for someone else?

1. Self → GO TO G26F 2. Someone else 3. Both DK/RF → GO TO G26F



G25FFF. [CYNAMF CYNAML]: [CYAQRTH], [CYFUHU], Age [AGEIWDATE] [(Respondent)]

Let's talk about the other person's Supplemental Security when we talk about their income.

- ENTER [1] to continue

1. Continue

G25F4 Rule: Whether SSI for Someone Else or Both

Someone Else (G25FF=2) → GO TO G25G	Both (G25FF=3)
	↓

G26F. [CYNAMF CYNAML]: [CYAQRTH], [CYFUHU], Age [AGEIWDATE] [(Respondent)]

How much was [G25FF=SELF: it / ALL OTHERS: the Supplemental Security Income [you / he / she] received for [yourself / himself / herself]]?

- ENTER amount here, then SELECT unit of time on next screen (Month, Year)

\$ 1 – 999,997 DK/RF → GO TO G27F



G26FPER. The amount entered is: [G26F] per ____

- SELECT the unit of time below

5. Month 6. Year 7. Other-specify (G26FPERSPEC. Specify. (String 100))

G27F. [CYNAMF CYNAML]: [CYAQRTH], [CYFUHU], Age [AGEIWDATE] [(Respondent)]

During which months of [PYEAR] did [you / [RP / SP]] get this income?

- ENTER all that apply
- PROBE: Any others?

1. January	2. February	3. March	4. April	5. May	6. June	
7. July	8. August	9. September	10. October	11. November	12. December	13. All

Other Welfare

G25G. [CYNAMF CYNAML]: [CYAQRTH], [CYFUHU], Age [AGEIWDATE] [(Respondent)]

(Did [you / [RP / SP]] receive any income in [PYEAR]...)

From other welfare?

1. Yes 5. No → GO TO G31CKPT



G26G. [CYNAMF CYNAML]: [CYAQRTH], [CYFUHU], Age [AGEIWDATE] [(Respondent)]

How much was it?

- ENTER amount here, then SELECT unit of time on next screen (Week, Two weeks, Month, Year)

\$ 1 – 999,997 DK/RF → GO TO G27G



G26GPER. The amount entered is: [G26G] per _____

- SELECT the unit of time below

3. Week	4. Two weeks	5. Month	6. Year
7. Other-specify (G26GPERSPEC. Specify. (String 100))			

G27G. [CYNAMF CYNAML]: [CYAQRTH], [CYFUHU], Age [AGEIWDATE] [(Respondent)]

During which months of [PYEAR] did [you / [RP / SP]] get this income?

- ENTER all that apply
- PROBE: Any others?

1. January	2. February	3. March	4. April	5. May	6. June	
7. July	8. August	9. September	10. October	11. November	12. December	13. All

Social Security

G31CKPT. CAI Checkpoint: Whether Spouse/Partner's Social Security Reported During Reference Person's Loop

1. Reference Person Loop	Spouse/Partner Loop	
↓	3. Social Security Not Reported	5. Social Security Already Reported
	↓	
	GO TO G37A	

G31. [CYNAMF CYNAML]: [CYAQRTH], [CYFUHU], Age [AGEIWDATE] [(Respondent)]

Did [RP LOOP: [you / [RP]] [or anyone else in the family there] / SP LOOP: Did [you / [SP]] receive any income in [PYEAR] from Social Security, such as disability, retirement or survivor's benefits?

- [RP LOOP: All Social Security received by any FU member must be reported here]

1. Yes 5. No → GO TO G37A



G32 Rule: Number of FU Members

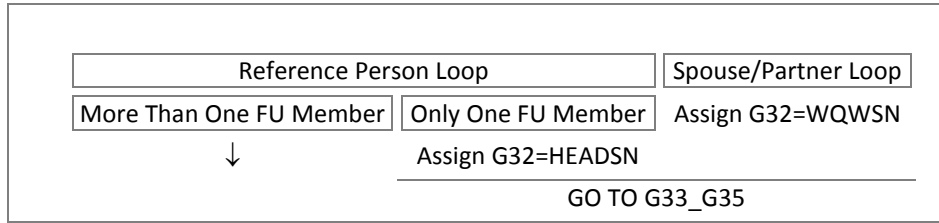

G32. [CYNAMF CYNAML]: [CYAQRTH], [CYFUHU], Age [AGEIWDATE] [(Respondent)]

Who was that?

- ENTER all that apply
- PROBE: Any others?

1 – 24. [CYNAMF CYNAML], [CYAQRTH], [CYFUHU] DK/RF → GO TO G37A

AQSN list of RP if FU, FUMI; SP if FU, FUMI; OFUM if FU, FUMI≤PYEAR, MO≥PYEAR, DECD≥PYEAR



SECTION_G.G12_G46G [1-2].G33_G35 1-24 [1]=Current RP, [2]=Current SP; [1-24]=AQSN of FU Member

G33A. [G32]: [CYAQRTH], [CYFUHU], Age [AGEIWDATE] [(Respondent)]

((First / Next),) let me ask about [your / [G32]'s] Social Security. Was that disability, retirement, survivor's benefits, or what?

- ENTER all that apply
- PROBE: Any others?

1. Disability	2. Retirement	3. Survivor's benefits	5. Dependent of disabled recipient
6. Dependent of retired recipient		7. Other-specify (G33ASPEC. Specify. (String 100))	

G34. [G32]: [CYAQRTH], [CYFUHU], Age [AGEIWDATE] [(Respondent)]

How much was the total amount from Social Security? [2+ SOCSEC INCOMES: Please include all amounts from all types of Social Security [you / [G32]] received in [PYEAR].]

- ENTER amount here, then SELECT unit of time on next screen (Month, Year)

\$ 1 – 999,997 DK/RF → GO TO G35



G34PER. The amount entered is: [G34] per ____

- SELECT the unit of time below

5. Month	6. Year	7. Other-specify (G34PERSPEC. Specify. (String 100))
----------	---------	--

G35. [G32]: [CYAQRTH], [CYFUHU], Age [AGEIWDATE] [(Respondent)]

During which months of [PYEAR] did [you / [G32]] get this income? [(This includes all types of Social Security [you / [G32]] received in [PYEAR].)]

- ENTER all that apply
- PROBE: Any others?

1. January	2. February	3. March	4. April	5. May	6. June	
7. July	8. August	9. September	10. October	11. November	12. December	13. All

G35 Rule: Whether More FU Members Reported at G32

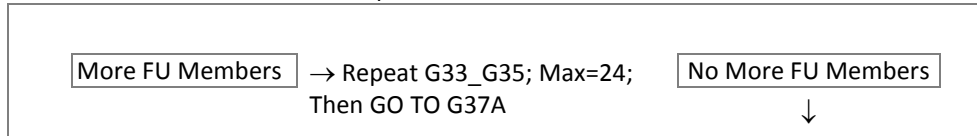

END G33_G35

Veterans Administration (VA) Pensions

G37A. [CYNAMF CYNAML]: [CYAQRTH], [CYFUHU], Age [AGEIWDATE] [(Respondent)]

Did [you / [RP / SP]] receive any income in [PYEAR] from the Veterans Administration for a servicemen's, [MALE CYAQRTH=101, 201, 221: (widow's,) / FEMALE CYAQRTH=102, 202, 222: widow's,] or survivor's pension, service disability, or the GI bill?

- ENTER all that apply
- PROBE: Any others?

1. Yes, servicemen's, widow's, or survivor's pension	2. Yes, service disability	
3. Yes, GI bill	4. Yes, other-specify (G37ASPEC. Specify. (String 100))	5. No → GO TO G40



G38. [CYNAMF CYNAML]: [CYAQRTH], [CYFUHU], Age [AGEIWDATE] [(Respondent)]

How much was the total amount? [2+ VA INCOMES: Please include all amounts from all types of VA (Veterans Administration) income [you / he / she] received in [PYEAR].]

- ENTER amount here, then SELECT unit of time on next screen (Month, Year)

\$ 1 – 999,997	DK/RF	→ GO TO G39
----------------	-------	-------------



G38PER. The amount entered is: [G38] per ____

- SELECT the unit of time below

5. Month	6. Year	7. Other-specify (G38PERSPEC. Specify. (String 100))
----------	---------	--

G39. [CYNAMF CYNAML]: [CYAQRTH], [CYFUHU], Age [AGEIWDATE] [(Respondent)]

During which months of [PYEAR] did [you / [RP / SP]] get this income? [(This includes all types of VA (Veterans Administration) income [you / he / she] received in [PYEAR].)]

- ENTER all that apply
- PROBE: Any others?

1. January	2. February	3. March	4. April	5. May	6. June
7. July	8. August	9. September	10. October	11. November	12. December
13. All					

Other Retirement

G40. [CYNAMF CYNAML]: [CYAQRTH], [CYFUHU], Age [AGEIWDATE] [(Respondent)]

Did [you / [RP / SP]] receive any income in [PYEAR] from other retirement pay, pensions, I.R.A.s (Individual Retirement Account) or annuities?

- ENTER all that apply
- PROBE: Any others?

1. Yes, retirement pay, pensions	2. Yes, annuities	3. Yes, other-specify	4. Yes, I.R.A.s	5. No
----------------------------------	-------------------	-----------------------	-----------------	-------



GO TO G44A

G40=Retirement Pay, Pensions

G41A. [CYNAMF CYNAML]: [CYAQRTH], [CYFUHU], Age [AGEIWDATE] [(Respondent)]

How much was from retirement pay or pensions?

- ENTER amount here, then SELECT unit of time on next screen (Month, Year)

\$ 1 – 999,997	DK/RF	→ GO TO G42A
----------------	-------	--------------



G41APER. The amount entered is: [G41A] per ____

- SELECT the unit of time below

5. Month	6. Year	7. Other-specify (G41APERSPEC. Specify. (String 100))
----------	---------	---

G42A. [CYNAMF CYNAML]: [CYAQRTH], [CYFUHU], Age [AGEIWDATE] [(Respondent)]

During which months of [PYEAR] did [you / he / she] get this income?

- ENTER all that apply
- PROBE: Any others?

1. January	2. February	3. March	4. April	5. May	6. June	
7. July	8. August	9. September	10. October	11. November	12. December	13. All

G40=Annuities

G41B. [CYNAMF CYNAML]: [CYAQRTH], [CYFUHU], Age [AGEIWDATE] [(Respondent)]

How much was from annuities?

- ENTER amount here, then SELECT unit of time on next screen (Month, Year)

\$ 1 – 999,997	DK/RF	→ GO TO G42B
----------------	-------	--------------



G41BPER. The amount entered is: [G41B] per ____

- SELECT the unit of time below

5. Month	6. Year	7. Other-specify (G41BPERSPEC. Specify. (String 100))
----------	---------	---

G42B. [CYNAMF CYNAML]: [CYAQRTH], [CYFUHU], Age [AGEIWDATE] [(Respondent)]

During which months of [PYEAR] did [you / [RP / SP]] get this income?

- ENTER all that apply
- PROBE: Any others?

1. January	2. February	3. March	4. April	5. May	6. June	
7. July	8. August	9. September	10. October	11. November	12. December	13. All

G40=Other

G41C. [CYNAMF CYNAML]: [CYAQRTH], [CYFUHU], Age [AGEIWDATE] [(Respondent)]

How much was the other (retirement) income?

- ENTER amount here, then SELECT unit of time on next screen (Month, Year)

\$ 1 – 999,997	DK/RF	→ GO TO G41C1
----------------	-------	---------------



G41CPER. The amount entered is: [G41C] per ____

- SELECT the unit of time below

5. Month	6. Year	7. Other-specify (G41CPERSPEC. Specify. (String 100))
----------	---------	---

G41C1. [CYNAMF CYNAML]: [CYAQRTH], [CYFUHU], Age [AGEIWDATE] [(Respondent)]

What was that (other retirement income) from?

String 200

G42C. [CYNAMF CYNAML]: [CYAQRTH], [CYFUHU], Age [AGEIWDATE] [(Respondent)]

During which months of [PYEAR] did [you / he / she] get this income?

- ENTER all that apply
- PROBE: Any others?

1. January	2. February	3. March	4. April	5. May	6. June	
7. July	8. August	9. September	10. October	11. November	12. December	13. All

G40=IRA

G41D. [CYNAMF CYNAML]: [CYAQRTH], [CYFUHU], Age [AGEIWDATE] [(Respondent)]

How much was from I.R.A.s (Individual Retirement Account)?

- ENTER amount here, then SELECT unit of time on next screen (Month, Year)

\$ 1 – 999,997 DK/RF → GO TO G42D



G41DPER. The amount entered is: [G41D] per ____

- SELECT the unit of time below

5. Month	6. Year	7. Other-specify (G41DPERSPEC. Specify. (String 100))
----------	---------	---

G42D. [CYNAMF CYNAML]: [CYAQRTH], [CYFUHU], Age [AGEIWDATE] [(Respondent)]

During which months of [PYEAR] did [you / he / she] get this income?

- ENTER all that apply
- PROBE: Any others?

1. January	2. February	3. March	4. April	5. May	6. June	
7. July	8. August	9. September	10. October	11. November	12. December	13. All

G43. [CYNAMF CYNAML]: [CYAQRTH], [CYFUHU], Age [AGEIWDATE] [(Respondent)]

(Not including Veterans Administration pensions,) how many different pensions, I.R.A.s (Individual Retirement Account) or annuities did [you / [RP / SP]] receive income from in [PYEAR]?

- FOR 7 or more, ENTER [7]

1 – 7

Unemployment Compensation

G44A. [CYNAMF CYNAML]: [CYAQRTH], [CYFUHU], Age [AGEIWDATE] [(Respondent)]

Did [you / [RP / SP]] receive any income in [PYEAR] from unemployment compensation?

1. Yes 5. No → GO TO G44B



G45A. [CYNAMF CYNAML]: [CYAQRTH], [CYFUHU], Age [AGEIWDATE] [(Respondent)]

How much was it?

- ENTER amount here, then SELECT unit of time on next screen (Week, Two weeks, Month, Year)

\$ 1 – 999,997 DK/RF → GO TO G46A



G45APER. The amount entered is: [G45A] per ____

- SELECT the unit of time below

3. Week	4. Two weeks	5. Month	6. Year
7. Other-specify (G45APERSPEC. Specify. (String 100))			

G46A. [CYNAMF CYNAML]: [CYAQRTH], [CYFUHU], Age [AGEIWDATE] [(Respondent)]

During which months of [PYEAR] did [you / he / she] get this income?

- ENTER all that apply
- PROBE: Any others?

1. January	2. February	3. March	4. April	5. May	6. June	
7. July	8. August	9. September	10. October	11. November	12. December	13. All

Workers Compensation

G44B. [CYNAMF CYNAML]: [CYAQRTH], [CYFUHU], Age [AGEIWDATE] [(Respondent)]

(Did [you / [RP / SP]] receive any income in [PYEAR]...)

From workers compensation?

1. Yes 5. No → GO TO G44C



G45B. [CYNAMF CYNAML]: [CYAQRTH], [CYFUHU], Age [AGEIWDATE] [(Respondent)]

How much was it?

- ENTER amount here, then SELECT unit of time on next screen (Month, Year)

\$ 1 – 999,997 DK/RF → GO TO G46B



G45BPER. The amount entered is: [G45B] per _____

- SELECT the unit of time below

5. Month 6. Year 7. Other-specify (G45BPERSPEC. Specify. (String 100))

G46B. [CYNAMF CYNAML]: [CYAQRTH], [CYFUHU], Age [AGEIWDATE] [(Respondent)]

During which months of [PYEAR] did [you / he / she] get this income?

- ENTER all that apply
- PROBE: Any others?

1. January	2. February	3. March	4. April	5. May	6. June	
7. July	8. August	9. September	10. October	11. November	12. December	13. All

Child Support

G44C. [CYNAMF CYNAML]: [CYAQRTH], [CYFUHU], Age [AGEIWDATE] [(Respondent)]

(Did [you / [RP / SP]] receive any income in [PYEAR]...)

From child support?

1. Yes 5. No → GO TO G44D



G45C. [CYNAMF CYNAML]: [CYAQRTH], [CYFUHU], Age [AGEIWDATE] [(Respondent)]

How much was it?

- ENTER amount here, then SELECT unit of time on next screen (Week, Two weeks, Month, Year)

\$ 1 – 999,997 DK/RF → GO TO G46C



G45CPER. The amount entered is: [G45C] per _____

- SELECT the unit of time below

3. Week 4. Two weeks 5. Month 6. Year
7. Other-specify (G45CPEXSPEC. Specify. (String 100))

G46C. [CYNAMF CYNAML]: [CYAQRTH], [CYFUHU], Age [AGEIWDATE] [(Respondent)]

During which months of [PYEAR] did [you / he / she] get this income?

- ENTER all that apply
- PROBE: Any others?

1. January	2. February	3. March	4. April	5. May	6. June	
7. July	8. August	9. September	10. October	11. November	12. December	13. All

Alimony or Separate Maintenance

G44D. [CYNAMF CYNAML]: [CYAQRTH], [CYFUHU], Age [AGEIWDATE] [(Respondent)]

(Did [you / [RP / SP]] receive any income in [PYEAR]...)

From alimony or separate maintenance?

1. Yes 5. No → GO TO G44E



G45D. [CYNAMF CYNAML]: [CYAQRTH], [CYFUHU], Age [AGEIWDATE] [(Respondent)]

How much was it?

- ENTER amount here, then SELECT unit of time on next screen (Week, Two weeks, Month, Year)

\$ 1 – 999,997 DK/RF → GO TO G46D



G45DPER. The amount entered is: [G45D] per ____

- SELECT the unit of time below

3. Week	4. Two weeks	5. Month	6. Year
7. Other-specify (G45DPERSPEC. Specify. (String 100))			

G46D. [CYNAMF CYNAML]: [CYAQRTH], [CYFUHU], Age [AGEIWDATE] [(Respondent)]

During which months of [PYEAR] did [you / he / she] get this income?

- ENTER all that apply
- PROBE: Any others?

1. January	2. February	3. March	4. April	5. May	6. June	
7. July	8. August	9. September	10. October	11. November	12. December	13. All

Help From Relatives

G44E. [CYNAMF CYNAML]: [CYAQRTH], [CYFUHU], Age [AGEIWDATE] [(Respondent)]

Did [you / [RP / SP]] receive any help in [PYEAR] from relatives?

- This must be from non-FU members.

1. Yes 5. No → GO TO G44F



G45E. [CYNAMF CYNAML]: [CYAQRTH], [CYFUHU], Age [AGEIWDATE] [(Respondent)]

How much was it?

- ENTER amount here, then SELECT unit of time on next screen (Week, Two weeks, Month, Year)

\$ 1 – 999,997 DK/RF → GO TO G46E



G45EPPER. The amount entered is: [G45E] per ____

- SELECT the unit of time below

3. Week	4. Two weeks	5. Month	6. Year
7. Other-specify (G45EPPERPEC. Specify. (String 100))			

G46E. [CYNAMF CYNAML]: [CYAQRTH], [CYFUHU], Age [AGEIWDATE] [(Respondent)]

During which months of [PYEAR] did [you / he / she] get this income?

- ENTER all that apply
- PROBE: Any others?

1. January	2. February	3. March	4. April	5. May	6. June	
7. July	8. August	9. September	10. October	11. November	12. December	13. All

Help From Non-Relatives

G44F. [CYNAMF CYNAML]: [CYAQRTH], [CYFUHU], Age [AGEIWDATE] [(Respondent)]

Did [you / [RP / SP]] receive any help in [PYEAR] from non-relatives or friends?

- This must be from non-FU members.

1. Yes 5. No → GO TO G44G



G45F. [CYNAMF CYNAML]: [CYAQRTH], [CYFUHU], Age [AGEIWDATE] [(Respondent)]

How much was it?

- ENTER amount here, then SELECT unit of time on next screen (Week, Two weeks, Month, Year)

\$ 1 – 999,997 DK/RF → GO TO G46F



G45FPER. The amount entered is: [G45F] per ____

- SELECT the unit of time below

3. Week	4. Two weeks	5. Month	6. Year
7. Other-specify (G45FPERSPEC. Specify. (String 100))			

G46F. [CYNAMF CYNAML]: [CYAQRTH], [CYFUHU], Age [AGEIWDATE] [(Respondent)]

During which months of [PYEAR] did [you / he / she] get this income?

- ENTER all that apply
- PROBE: Any others?

1. January	2. February	3. March	4. April	5. May	6. June	
7. July	8. August	9. September	10. October	11. November	12. December	13. All

Other Income

G44G. [CYNAMF CYNAML]: [CYAQRTH], [CYFUHU], Age [AGEIWDATE] [(Respondent)]

Did [you / [RP / SP]] receive any other income in [PYEAR] from anything else?

1. Yes 5. No → GO TO R1CKPT



G45G1. [CYNAMF CYNAML]: [CYAQRTH], [CYFUHU], Age [AGEIWDATE] [(Respondent)]

What was that from?

- IF R mentions income from a job, probe for these details:
- Occ/Ind: What was [your / his / her] occupation? What sort of work did [you / he / she] do? (DO NOT PROBE)
- Start/End: What month and year did [you / he / she] start that job? End that job?
- Job Title/Commute: What was [your / his / her] official job title? On a typical day, how many minutes was [your / his / her] round trip commute to and from work?
- Work hours: How many weeks did [you / he / she] work at that job in [PYEAR]? On average, how many hours per week did [you / he / she] work in [PYEAR]?
- To SAVE your entry, use Alt-S

Open End

G45G. [CYNAMF CYNAML]: [CYAQRTH], [CYFUHU], Age [AGEIWDATE] [(Respondent)]

How much was the income from that?

- ENTER amount here, then SELECT unit of time on next screen (Week, Two weeks, Month, Year)

\$ 1 – 999,997 DK/RF → GO TO G46G



G45GPER. The amount entered is: [G45G] per ____

- SELECT the unit of time below

3. Week	4. Two weeks	5. Month	6. Year
7. Other-specify (G45GPERSPEC. Specify. (String 100))			

G46G. [CYNAMF CYNAML]: [CYAQRTH], [CYFUHU], Age [AGEIWDATE] [(Respondent)]

During which months of [PYEAR] did [you / he / she] get this income?

- ENTER all that apply
- PROBE: Any others?

1. January	2. February	3. March	4. April	5. May	6. June	
7. July	8. August	9. September	10. October	11. November	12. December	13. All

P2Year Income – Reference Person and Spouse/Partner

R1CKPT. CAI Checkpoint: Whether Worked in P2YEAR

1. Worked in P2YEAR (BCWTRP2YEAR=1 for Any Job)	5. All Others	→ GO TO G49 RULE
---	---------------	------------------

↓

R2. [CYNAMF CYNAML]: [CYAQRTH], [CYFUHU], Age [AGEIWDATE] [(Respondent)]

Earlier you reported that [you were / [RP / SP] was] working in [P2YEAR]. Thinking now about all the work for money that [you / he / she] did during [P2YEAR], including jobs, businesses, self-employment and part-time work, about how much did [you / he / she] earn altogether in [P2YEAR]? Please include any income from bonuses, overtime, tips or commissions.

(Including the jobs we already talked about)

[READ employers if needed](#)

[\[List of P2YEAR Employers from EHC\]](#)

- IF necessary: Please give me your best estimate
- ENTER amount here, then SELECT unit of time on next screen (Hour, Week, Two weeks, Month, Year)

\$ 1 – 9,999,997.99 DK/RF → GO TO G49 RULE



R2PER. The amount entered is: [R2] per ____

- SELECT the unit of time below

1. Hour	3. Week	4. Two weeks	5. Month	6. Year
7. Other-specify (R2PERSPEC. Specify. (String 100))				

G49 Rule: Whether Spouse/Partner in FU

Spouse/Partner (CYAQRTH=201-222, CYFUHU=FU, FUMI)	→ Repeat G12_G46G; Then GO TO G73CKPT	No Spouse/Partner
---	--	-------------------

↓

END G12_G46G

PYear Income - Big OFUM Age 16 or Older

G73CKPT[1-24]. CAI Checkpoint: Section G Big OFUM Qualifier ([1-24]= AQSN of FU Member)

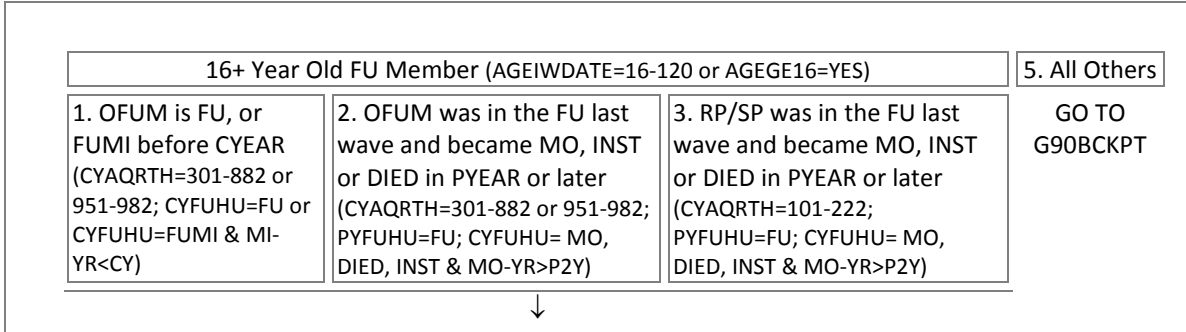

SECTION_G.G73_G90 [1-24] [1-24]= AQSN of FU Member

G73. AQSN of FU Member

G74 Rule: Whether FU Member Deceased

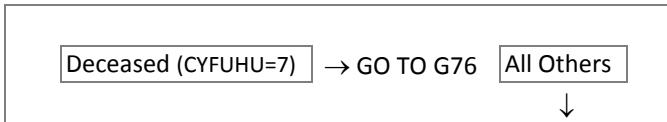

Jobs and Earnings

G75. [CYNAMF CYNAML], [CYAQRTH], [AGEIWDATE]

Next we would like to know a little about [CYNAMF CYNAML]. [Are you / Is [he / she]] working now, looking for work, retired, a student, keeping house, or what?

- ENTER all that apply
- PROBE: Any others?

1. Working now	2. Only temporarily laid off	3. Looking for work, unemployed
4. Retired	5. Disabled, permanently or temporarily	6. Keeping house
7. Student	8. Other-specify (G75SPEC. Specify (String 100))	

G76. [CYNAMF CYNAML], [CYAQRTH], [AGEIWDATE]

[THIS FU MEMBER DECEASED: Next, we would like to know a little about [CYNAMF CYNAML].]

During [PYEAR], how many full-time or part-time jobs did [you / he / she] have (not counting work around the house)?

1. Only one job	2. Two jobs	3. Three jobs	4. Four jobs	5. Didn't have a job	DK/RF
-----------------	-------------	---------------	--------------	----------------------	-------

↓

GO TO G83

SECTION_G.G73_G90 [1-24].G77_G81 [1-4] [1-24]=AQSN of FU Member; [1-4]=Which job

G77. [CYNAMF CYNAML], [CYAQRTH], [AGEIWDATE]

[First / Second / Third / Fourth] Job

[JOBS 2-4: (For the next job...)]

What kind of work did [you / he / she] usually do? What was [your / his / her] occupation?

- [1st JOB AND G76=2-4: R reported multiple jobs -- ask for the main job here]
- DO NOT PROBE

String 500

G77A Rule: Whether First Job Loop (Main Job)

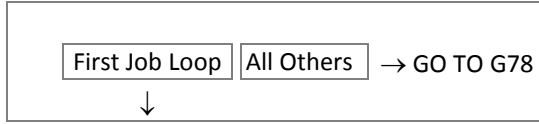

G77A. [CYNAMF CYNAML], [CYAQRTH], [AGEIWDAT]E

First Job

What was the official title of [your / his / her] job? (The title that [your / his / her] employer used.)

- [1st JOB AND G76=2-4: R reported multiple jobs -- ask for the [main](#) job here]
- DO NOT PROBE

String 200

G77B. [CYNAMF CYNAML], [CYAQRTH], [AGEIWDAT]E

First Job

On a typical day, how many minutes was [your / his / her] round trip commute to and from work?

- [1st JOB AND G76=2-4: R reported multiple jobs -- ask for the [main](#) job here]
- If R says "travels from home to temporary lodging near worksite", ENTER [995]
- If R says "it varies", ENTER [996]
- If R says "doesn't commute" (e.g. self-employed, works from home), ENTER [997]

1 – 900 | 995. Temp lodging (VOL) | 996. It varies (VOL) | 997. No commute (VOL)

G78. [CYNAMF CYNAML], [CYAQRTH], [AGEIWDAT]E

[First / Second / Third / Fourth] Job

About how much money did [you / he / she] earn from that job last year ([PYEAR])?

- [1st JOB AND G76=2-4: R reported multiple jobs -- ask for the [main](#) job here]
- ENTER amount here, then SELECT unit of time on next screen (Hour, Week, Two weeks, Month, Year)

\$ 1 – 9,999,997.99 | DK/RF → GO TO G79



G78PER. The amount entered is: [G78] per ____

- SELECT the unit of time below

1. Hour | 3. Week | 4. Two weeks | 5. Month | 6. Year

7. Other-specify (G78PERSPEC. Specify. (String 100))

G79. [CYNAMF CYNAML], [CYAQRTH], [AGEIWDAT]E

[First / Second / Third / Fourth] Job

About how many weeks did [you / he / she] work on that job last year ([PYEAR])?

- [1st JOB AND G76=2-4: R reported multiple jobs -- ask for the [main](#) job here]

1 – 52

G80. [CYNAMF CYNAML], [CYAQRTH], [AGEIWDAT]E

[First / Second / Third / Fourth] Job

During which months was that?

- [1st JOB AND G76=2-4: R reported multiple jobs -- ask for the [main](#) job here]
- ENTER all that apply
- PROBE: Any others?

1. January	2. February	3. March	4. April	5. May	6. June	
7. July	8. August	9. September	10. October	11. November	12. December	13. All

G81. [CYNAMF CYNAML], [CYAQRTH], [AGEIWDATE]

[First / Second / Third / Fourth] Job

During the weeks that [you / he / she] worked, about how many hours did [you / he / she] usually work per week?

- [1st JOB AND G76=2-4: R reported multiple jobs -- ask for the main job here]
- ROUND DOWN for fractions less than ½ (0.5)
- ROUND UP for fractions ½ (0.5) or more

1 – 112

G82 Rule: Whether More Jobs at G76

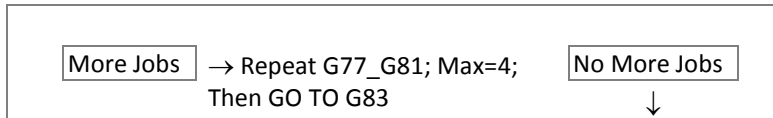

END G77_G81

Other Income

G83. [CYNAMF CYNAML], [CYAQRTH], [AGEIWDATE]

Did [you / he / she] have any [other] income, such as pensions, welfare, interest, gifts, or anything else, last year ([PYEAR])?

1. Yes 5. No → GO TO G88CKPT



G84. [CYNAMF CYNAML], [CYAQRTH], [AGEIWDATE]

What was that from?

- ENTER all that apply
- PROBE: Any others?
- SSI (Supplemental Security Income) is **not** Social Security, nor is it Social Security Disability Insurance (SSDI), although the Social Security Administration administers the program and a person can receive both. See F1-Help for more information.

1. Interest	2. TANF/[STATEPROG]	3. SSI	4. Welfare
5. Social Security	6. Veterans benefits	7. Pensions, annuities	
8. Unemployment comp	9. Worker's comp	10. Child support	
11. Help from relatives	12. Other-specify	DK/RF	→ GO TO G88CKPT



G84=Interest

G84A. [CYNAMF CYNAML], [CYAQRTH], [AGEIWDATE]

How much was from interest?

- ENTER amount here, then SELECT unit of time on next screen (Month, Year)

\$ 1 – 999,997 DK/RF → GO TO G84AA



G84APER. The amount entered is: [G84A] per ____

- SELECT the unit of time below

5. Month	6. Year	7. Other-specify (G84APERSPEC. Specify. (String 100))
----------	---------	---

G84AA. [CYNAMF CYNAML], [CYAQRTH], [AGEIWDATE]

During which months of [PYEAR] did [you / he / she] get this income?

- ENTER all that apply
- PROBE: Any others?

1. January	2. February	3. March	4. April	5. May	6. June	
7. July	8. August	9. September	10. October	11. November	12. December	13. All

G84=TANF

G84B. [CYNAMF CYNAML], [CYAQRTH], [AGEIWDATE]

How much was from TANF (Temporary Assistance for Needy Families) [PYSTATERESIDE<>FC/DK/RF: or [STATEPROG]]?

- ENTER amount here, then SELECT unit of time on next screen (Two weeks, Month, Year)

\$ 1 – 999,997 DK/RF → GO TO G84BB



G84BPER. The amount entered is: [G84B] per _____

- SELECT the unit of time below

4. Two weeks	5. Month	6. Year	7. Other-specify (G84BPERSPEC. Specify. (String 100))
--------------	----------	---------	---

G84BB. [CYNAMF CYNAML], [CYAQRTH], [AGEIWDATE]

During which months of [PYEAR] did [you / he / she] get this income?

- ENTER all that apply
- PROBE: Any others?

1. January	2. February	3. March	4. April	5. May	6. June	
7. July	8. August	9. September	10. October	11. November	12. December	13. All

G84BBB. [CYNAMF CYNAML], [CYAQRTH], [AGEIWDATE]

Who in the family was covered by this?

- ENTER all that apply
- PROBE: Any others?

1 – 24. [CYNAMF CYNAML], [CYAQRTH], [CYFUHU] *AQSN list of FU Members if FU, FUMI≤PY, MO≥PY, DEC≥PY, MILT, EDUC, HLTH, OTHR*

G84=SSI

G84C1. [CYNAMF CYNAML], [CYAQRTH], [AGEIWDATE]

Did [you / he / she] receive the SSI for [yourself / himself / herself], or for someone else?

- SSI (Supplemental Security Income) is **not** Social Security, nor is it Social Security Disability Insurance (SSDI), although the Social Security Administration administers the program and a person can receive both. See F1-Help for more information.

1. Self → GO TO G84C4 2. Someone else 3. Both DK/RF → GO TO G84C4



G84C2. [CYNAMF CYNAML], [CYAQRTH], [AGEIWDATE]

Let's talk about the other person's Supplemental Security when we talk about their income.

- ENTER [1] to continue

1. Continue

G84C3 Rule: Whether SSI for Someone Else or Both

<input type="text" value="Someone Else (G84C1=2)"/> → GO TO Next G84 Item, or G88CKPT	<input type="text" value="Both (G84C1=3)"/>
↓	

G84C4. [CYNAMF CYNAML], [CYAQRTH], [AGEIWDATE]

How much was [G84C1=SELF: it / ALL OTHERS: the Supplemental Security Income [you / he / she] received for [yourself / himself / herself]]?

- ENTER amount here, then SELECT unit of time on next screen (Month, Year)

→ GO TO G84C5



G84C4PER. The amount entered is: [G84C4] per ____

- SELECT the unit of time below

G84C5. [CYNAMF CYNAML], [CYAQRTH], [AGEIWDATE]

During which months of [PYEAR] did [you / he / she] get this income?

- ENTER all that apply
- PROBE: Any others?

1. January	2. February	3. March	4. April	5. May	6. June	
7. July	8. August	9. September	10. October	11. November	12. December	13. All

G84=Other Welfare

G84D. [CYNAMF CYNAML], [CYAQRTH], [AGEIWDATE]

How much was from welfare?

- ENTER amount here, then SELECT unit of time on next screen (Week, Two weeks, Month, Year)

→ GO TO G84DD



G84DPER. The amount entered is: [G84D] per ____

- SELECT the unit of time below

G84DD. [CYNAMF CYNAML], [CYAQRTH], [AGEIWDATE]

During which months of [PYEAR] did [you / he / she] get this income?

- ENTER all that apply
- PROBE: Any others?

1. January	2. February	3. March	4. April	5. May	6. June	
7. July	8. August	9. September	10. October	11. November	12. December	13. All

G84=Social Security

G84ECKPT. CAI Checkpoint: Whether Social Security Already Reported For This OFUM at G32

<input type="text" value="1. Not Reported"/> <input type="text" value="5. Already Reported"/> → GO TO Next G84 Item; or G88CKPT
↓

G84E2A. [CYNAMF CYNAML], [CYAQRTH], [AGEIWDATE]

What was the Social Security? Was that disability, retirement, survivor's benefits or what?

- ENTER all that apply
- PROBE: Any others?

1. Disability	2. Retirement	3. Survivor's benefits	5. Dependent of disabled recipient
6. Dependent of retired recipient	7. Other-specify (G84E2ASPEC. Specify. (String 100))		

G84E3. [CYNAMF CYNAML], [CYAQRTH], [AGEIWDATE]

How much was the total amount from Social Security? [2+ SOCSEC INCOMES: Please include all amounts from all types of Social Security [you / he / she] received in [PYEAR].]

- ENTER amount here, then SELECT unit of time on next screen (Month, Year)

\$ 1 – 999,997	DK/RF	→ GO TO G84E4
----------------	-------	---------------



G84E3PER. The amount entered is: [G84E3] per ____

- SELECT the unit of time below

5. Month	6. Year	7. Other-specify (G84E3PERSPEC. Specify. (String 100))
----------	---------	--

G84E4. [CYNAMF CYNAML], [CYAQRTH], [AGEIWDATE]

During which months of [PYEAR] did [you / he / she] get this income? [(This includes all types of Social Security [you / he / she] received in [PYEAR].)]

- ENTER all that apply
- PROBE: Any others?

1. January	2. February	3. March	4. April	5. May	6. June	
7. July	8. August	9. September	10. October	11. November	12. December	13. All

G84=Veterans benefits

G84F. [CYNAMF CYNAML], [CYAQRTH], [AGEIWDATE]

How much was from veteran's benefits?

- ENTER amount here, then SELECT unit of time on next screen (Month, Year)
- If needed: This includes all types of VA (Veterans Administration) income [you / he / she] received in [PYEAR].

\$ 1 – 999,997	DK/RF	→ GO TO G84FF
----------------	-------	---------------



G84FPER. The amount entered is: [G84F] per ____

- SELECT the unit of time below

5. Month	6. Year	7. Other-specify (G84FPERSPEC. Specify. (String 100))
----------	---------	---

G84FF. [CYNAMF CYNAML], [CYAQRTH], [AGEIWDATE]

During which months of [PYEAR] did [you / he / she] get this income?

- ENTER all that apply
- PROBE: Any others?
- If needed: This includes all types of VA (Veterans Administration) income [you / he / she] received in [PYEAR].

1. January	2. February	3. March	4. April	5. May	6. June	
7. July	8. August	9. September	10. October	11. November	12. December	13. All

G84=Pensions, annuities

G84G. [CYNAMF CYNAML], [CYAQRTH], [AGEIWDATE]

How much was from pensions or annuities?

- ENTER amount here, then SELECT unit of time on next screen (Month, Year)

\$ 1 – 999,997	DK/RF	→ GO TO G84GG
----------------	-------	---------------



G84GPER. The amount entered is: [G84G] per ____

- SELECT the unit of time below

5. Month	6. Year	7. Other-specify (G84GPERSPEC. Specify. (String 100))
----------	---------	---

G84GG. [CYNAMF CYNAML], [CYAQRTH], [AGEIWDATE]

During which months of [PYEAR] did [you / he / she] get this income?

- ENTER all that apply
- PROBE: Any others?

1. January	2. February	3. March	4. April	5. May	6. June	
7. July	8. August	9. September	10. October	11. November	12. December	13. All

G84=Unemployment compensation

G84H. [CYNAMF CYNAML], [CYAQRTH], [AGEIWDATE]

How much was from unemployment compensation?

- ENTER amount here, then SELECT unit of time on next screen (Week, Two weeks, Month, Year)

\$ 1 – 999,997	DK/RF	→ GO TO G84HH
----------------	-------	---------------



G84HPER. The amount entered is: [G84H] per ____

- SELECT the unit of time below

3. Week	4. Two weeks	5. Month	6. Year
7. Other-specify (G84HPERSPEC. Specify. (String 100))			

G84HH. [CYNAMF CYNAML], [CYAQRTH], [AGEIWDATE]

During which months of [PYEAR] did [you / he / she] get this income?

- ENTER all that apply
- PROBE: Any others?

1. January	2. February	3. March	4. April	5. May	6. June	
7. July	8. August	9. September	10. October	11. November	12. December	13. All

G84=Worker's compensation

G84J. [CYNAMF CYNAML], [CYAQRTH], [AGEIWDATE]

How much was from worker's compensation?

- ENTER amount here, then SELECT unit of time on next screen (Month, Year)

\$ 1 – 999,997	DK/RF	→ GO TO G84JJ
----------------	-------	---------------



G84JPER. The amount entered is: [G84J] per ____

- SELECT the unit of time below

5. Month	6. Year	7. Other-specify (G84JPERSPEC. Specify. (String 100))
----------	---------	---

G84J. [CYNAMF CYNAML], [CYAQRTH], [AGEIWDATE]

During which months of [PYEAR] did [you / he / she] get this income?

- ENTER all that apply
- PROBE: Any others?

1. January	2. February	3. March	4. April	5. May	6. June	
7. July	8. August	9. September	10. October	11. November	12. December	13. All

G84=Child support

G84K. [CYNAMF CYNAML], [CYAQRTH], [AGEIWDATE]

How much was from child support?

- ENTER amount here, then SELECT unit of time on next screen (Week, Two weeks, Month, Year)

\$ 1 – 999,997 DK/RF → GO TO G84KK



G84KPER. The amount entered is: [G84K] per ____

- SELECT the unit of time below

3. Week	4. Two weeks	5. Month	6. Year
7. Other-specify (G84KERSPEC. Specify. (String 100))			

G84KK. [CYNAMF CYNAML], [CYAQRTH], [AGEIWDATE]

During which months of [PYEAR] did [you / he / she] get this income?

- ENTER all that apply
- PROBE: Any others?

1. January	2. February	3. March	4. April	5. May	6. June	
7. July	8. August	9. September	10. October	11. November	12. December	13. All

G84=Help from relatives

G84L. [CYNAMF CYNAML], [CYAQRTH], [AGEIWDATE]

How much was received from relatives?

- This must be from non-FU members
- ENTER amount here, then SELECT unit of time on next screen (Week, Two weeks, Month, Year)

\$ 1 – 999,997 DK/RF → GO TO G84LL



G84LPER. The amount entered is: [G84L] per ____

- SELECT the unit of time below

3. Week	4. Two weeks	5. Month	6. Year
7. Other-specify (G84LPERSPEC. Specify. (String 100))			

G84LL. [CYNAMF CYNAML], [CYAQRTH], [AGEIWDATE]

During which months of [PYEAR] did [you / he / she] get this income?

- ENTER all that apply
- PROBE: Any others?

1. January	2. February	3. March	4. April	5. May	6. June	
7. July	8. August	9. September	10. October	11. November	12. December	13. All

G84=Other

G84M. [CYNAMF CYNAML], [CYAQRTH], [AGEIWDATE]

What was that other income from?

- IF R mentions income from a job, PROBE for these details:
- Occ/Ind: What was [your / his / her] occupation? What sort of work did [you / he / she] do? (DO NOT PROBE)
- Start/End: What month and year did [you / he / she] start that job? End that job?
- Job Title/Commute: What was [your / his / her] official job title? On a typical day, how many minutes was [your / his / her] round trip commute to and from work?
- Work Hours: How many weeks did [you / he / she] work at that job in [PYEAR]? On average, how many hours per week did [you / he / she] work in [PYEAR]?
- To SAVE your entry, use Alt-S

Open End

G84MM. [CYNAMF CYNAML], [CYAQRTH], [AGEIWDATE]

How much was that from that (other income)?

- ENTER amount here, then SELECT unit of time on next screen (Week, Two weeks, Month, Year)

\$ 1 – 999,997 DK/RF → GO TO G84M3



G84MMPER. The amount entered is: [G84MM] per ____

- SELECT the unit of time below

3. Week	4. Two weeks	5. Month	6. Year
7. Other-specify (G84MMPERSPEC. Specify. (String 100))			

G84M3. [CYNAMF CYNAML], [CYAQRTH], [AGEIWDATE]

During which months of [PYEAR] did [you / he / she] get this income?

- ENTER all that apply
- PROBE: Any others?

1. January	2. February	3. March	4. April	5. May	6. June	
7. July	8. August	9. September	10. October	11. November	12. December	13. All

Education - New Big OFUM Age 16-49

G88CKPT. CAI Checkpoint: Whether Big OFUM is New, or Returning and Reported Education Last Wave

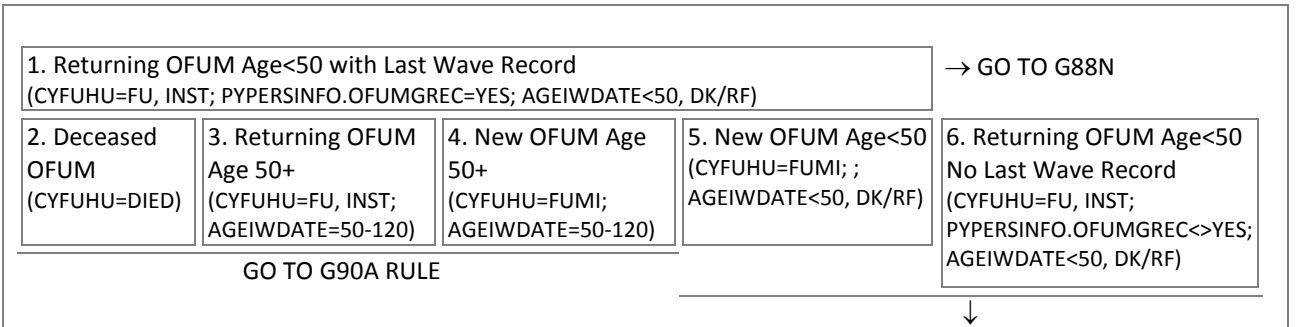

SECTION_G.G73_G90 [1-24].G88AG88M3 [1-24]=AQS of FU Member

G88A. [CYNAMF CYNAML], [CYAQRTH], [AGEIWDATE]

Where did [you / [CYNAMF CYNAML]] receive [your / her / his] education — in the United States, outside the United States, or both?

1. United States only	2. Outside U.S. only	3. Both in U.S. and outside	DK	5. Had no education	RF
↓	GO TO G88LCKPT	↓		GO TO G88LCKPT	

G88B1. [CYNAMF CYNAML], [CYAQRTH], [AGEIWDATE]

Now I would like to talk about the education [you have / [she / he] has] received. Did [you / he / she] graduate from high school, get a GED, or neither?

- ENTER [3] if R says OFUM is still in school (attending grade 1-12) or working on a GED

1. Graduated from high school	2. Got a GED	3. Neither	DK/RF
↓	GO TO G88C1	GO TO G88E1	GO TO G88F1

G88B2MO. [CYNAMF CYNAML], [CYAQRTH], [AGEIWDATE]

In what month and year did [you / she / he] graduate?

- SELECT Month and [Enter] to go to next screen for year
- IF NECESSARY: What would be your best estimate?

1. January	2. February	3. March	4. April	5. May	6. June
7. July	8. August	9. September	10. October	11. November	12. December
21. Winter	22. Spring	23. Summer	24. Fall		

G88B2YR. [CYNAMF CYNAML], [CYAQRTH], [AGEIWDATE]

(In what month and year did [you / she / he] graduate?)

- The month entered is: [G88BMO]
- ENTER the year below

1920 – [CYEAR]	→ GO TO G88F1
----------------	---------------

G88C1. [CYNAMF CYNAML], [CYAQRTH], [AGEIWDATE]

How many grades of regular school did [you / she / he] finish prior to getting [your / her / his] GED?

- Record last grade finished prior to receiving GED
- If needed: Regular school includes high school and schooling that leads to a college or professional school degree.

0. None	1. First grade	2. Second grade	3. Third grade
GO TO	4. Fourth grade	5. Fifth grade	6. Sixth grade
G88D1MO	7. Seventh grade	8. Eighth grade	9. Ninth grade
	10. Tenth grade	11. Eleventh grade	DK/RF → GO TO G88D1MO



G88C2MO. [CYNAMF CYNAML], [CYAQRTH], [AGEIWDATE]

In what month and year did [you / she / he] last attend [G88C1]?

- SELECT Month and [Enter] to go to next screen for year
- IF NECESSARY: What would be your best estimate?

1. January	2. February	3. March	4. April	5. May	6. June
7. July	8. August	9. September	10. October	11. November	12. December
21. Winter	22. Spring	23. Summer	24. Fall		

G88C2YR. [CYNAMF CYNAML], [CYAQRTH], [AGEIWDATE]
 (In what month and year did [you / she / he] last attend [G88C1]?)
 The month entered is: [G88C2MO]
 • ENTER the year below

1920 – [CYEAR]

G88D1MO. [CYNAMF CYNAML], [CYAQRTH], [AGEIWDATE]
 In what month and year did [you / she / he] receive [your / her / his] GED?
 • SELECT Month and [Enter] to go to next screen for year
 • IF NECESSARY: What would be your best estimate?

1. January	2. February	3. March	4. April	5. May	6. June
7. July	8. August	9. September	10. October	11. November	12. December
21. Winter	22. Spring	23. Summer	24. Fall		

G88D1YR. [CYNAMF CYNAML], [CYAQRTH], [AGEIWDATE]
 (In what month and year did [you / she / he] receive [your / her / his] GED?)
 The month entered is: [G88D1MO]
 • ENTER the year below

1920 – [CYEAR] → GO TO G88F1

G88E1. [CYNAMF CYNAML], [CYAQRTH], [AGEIWDATE]
 How many grades of regular school did [you / she / he] finish?
 • Record last grade finished
 • If needed: Regular school includes high school and schooling that leads to a college or professional school degree.

0. None	1. First grade	2. Second grade	3. Third grade
GO TO G88F1	4. Fourth grade	5. Fifth grade	6. Sixth grade
	7. Seventh grade	8. Eighth grade	9. Ninth grade
	10. Tenth grade	11. Eleventh grade	DK/RF → GO TO G88F1



G88E2MO. [CYNAMF CYNAML], [CYAQRTH], [AGEIWDATE]
 In what month and what year did [you / she / he] last attend [G88E1]?
 • SELECT Month and [Enter] to go to next screen for year
 • IF NECESSARY: What would be your best estimate?

1. January	2. February	3. March	4. April	5. May	6. June
7. July	8. August	9. September	10. October	11. November	12. December
21. Winter	22. Spring	23. Summer	24. Fall		

G88E2YR. [CYNAMF CYNAML], [CYAQRTH], [AGEIWDATE]
 (In what month and what year did [you / she / he] last attend [G88E1]?)
 The month entered is: [G88E2MO]
 • ENTER the year below

1920 – [CYEAR]

G88F1. [CYNAMF CYNAML], [CYAQRTH], [AGEIWDATE]

Did [you / she / he] attend college?

1. Yes 5. No → GO TO G88LCKPT



G88F2MO. [CYNAMF CYNAML], [CYAQRTH], [AGEIWDATE]

In what month and year did [you / she / he] last attend college?

- If still in school, ENTER [96] for month
- SELECT Month and [Enter] to go to next screen for year
- NECESSARY: What would be your best estimate?

1. January	2. February	3. March	4. April	5. May	6. June	
7. July	8. August	9. September	10. October	11. November	12. December	96. Still in school
21. Winter	22. Spring	23. Summer	24. Fall	DK/RF		



GO TO G88G

G882FYR. [CYNAMF CYNAML], [CYAQRTH], [AGEIWDATE]

(In what month and year did [you / she / he] last attend college?)

The month entered is: [G88F2MO]

- ENTER the year below
- 9996 If still in school

1920 – [CYEAR] 9996. Still in school

G88G. [CYNAMF CYNAML], [CYAQRTH], [AGEIWDATE]

What is the highest year of college [you have / [he / she] has] completed?

- IF R gives a degree: How many years of college [have you / has [she / he]] completed? We'll talk about any college degrees [you have / [he / she] has] earned next.

0. Less than one year	1. One year	2. Two years	3. Three years
GO TO G88LCKPT	4. Four years	5. Five years or more	DK/RF



G88H1. [CYNAMF CYNAML], [CYAQRTH], [AGEIWDATE]

Did [you / she / he] receive a college degree?

1. Yes 5. No → GO TO G88LCKPT



G88H2. [CYNAMF CYNAML], [CYAQRTH], [AGEIWDATE]

What is the highest college degree [you have / [he / she] has] received?

- PROBE for the **highest** degree received

1. Associate's degree/AA	3. Master's degree/MA/MS/MBA
2. Bachelor's degree/BA/BS	4. Doctorate/PhD 5. LLB, JD (Law degrees)
	6. MD, DDS, DVM, DO (Medical degrees)
	8. Honorary degree 97. Other-specify (G88H2SPEC. Specify (String 100))
DK/RF	

GO TO G88J



G88H3. [CYNAMF CYNAML], [CYAQRTH], [AGEIWDATE]

What was [your / her / his] major or majors at the college or university from which [you / he / she] received [your / his / her] bachelor's degree?

- Probe for details and dual majors

String 100

G88H4. [CYNAMF CYNAML], [CYAQRTH], [AGEIWDATE]

What was the name of the college or university?

- **If needed:** What was the name of the college or university from which [you / she / he] received [your / her / his] bachelor's degree?

String 100

G88H5CITY. [CYNAMF CYNAML], [CYAQRTH], [AGEIWDATE]

Where was it located?

- **If needed:** In what city and state was the college or university from which [you / she / he] received [your / her / his] bachelor's degree?

String 100

G88H5STATE. [CYNAMF CYNAML], [CYAQRTH], [AGEIWDATE]

(Where was it located?)

- **If needed:** In what state was the college or university from which [you / she / he] received [your / her / his] bachelor's degree?
- **Start typing the name of the State to bring up the look-up list**
- **IF foreign country, ENTER [FOR] to select "Foreign Country"**

String 30; U.S. State → GO TO Foreign Country DK/RF → GO TO
 G88H6MO ↓ G88H6MO

G88H5COUNTRY. [CYNAMF CYNAML], [CYAQRTH], [AGEIWDATE]

(Where was it located?)

- **If needed:** In what country was the college or university from which [you / she / he] received [your / her / his] bachelor's degree?
- **Start typing the name of the Foreign Country to bring up the look-up list**

String 30; Country

G88H6MO. [CYNAMF CYNAML], [CYAQRTH], [AGEIWDATE]

In what month and year did [you / he / she] receive [your / his / her] bachelor's degree?

- **SELECT Month and [Enter] to go to next screen for year**
- **IF NECESSARY:** What would be your best estimate?

1. January	2. February	3. March	4. April
5. May	6. June	7. July	8. August
9. September	10. October	11. November	12. December
21. Winter	22. Spring	23. Summer	24. Fall

G88H6YR. [CYNAMF CYNAML], [CYAQRTH], [AGEIWDATE]

(In what month and year did [you / he / she] receive [your / his / her] bachelor's degree?

The month entered is: [G88H6MO]

- **ENTER the year below**

1920 – [CYEAR]

G88J. [CYNAMF CYNAML], [CYAQRTH], [AGEIWDATE] [G88H2]

(And) What was [your / her / his] [G88H2=BACHELORS: major or majors / ALL OTHERS: area of study] at the college or university from which [you / he / she] received [your / his / her] highest degree?

- Probe for details and dual majors

String 100

G88K1. [CYNAMF CYNAML], [CYAQRTH], [AGEIWDATE] [G88H2]

What was the name of the college or university?

- **If needed:** What was the name of the college or university from which [you / she / he] received [your / her / his] highest degree?

String 100

G88K2CITY. [CYNAMF CYNAML], [CYAQRTH], [AGEIWDATE] [G88H2]

Where was it located?

- **If needed:** In what city and state was the college or university from which [you / she / he] received [your / her / his] highest degree?

String 100

G88K2STATE. [CYNAMF CYNAML], [CYAQRTH], [AGEIWDATE] [G88H2]

(Where was it located?)

- **If needed:** In what state was the college or university from which [you / she / he] received [your / her / his] highest degree?
- Start typing the name of the State to bring up the look-up list
- IF foreign country, ENTER [FOR] to select "Foreign Country"

String 30; U.S. State → GO TO G88K3MO Foreign Country ↓ DK/RF → GO TO G88K3MO

G88K2COUNTRY. [CYNAMF CYNAML], [CYAQRTH], [AGEIWDATE] [G88H2]

(Where was it located?)

- **If needed:** In what country was the college or university from which [you / she / he] received [your / her / his] highest degree?
- Start typing the name of the Foreign Country to bring up the look-up list

String 30; Country

G88K3MO. [CYNAMF CYNAML], [CYAQRTH], [AGEIWDATE] [G88H2]

In what month and year did [you / he / she] receive [your / his / her] highest degree?

- **SELECT** Month and [Enter] to go to next screen for year
- **IF NECESSARY:** What would be your best estimate?

1. January	2. February	3. March	4. April	5. May	6. June
7. July	8. August	9. September	10. October	11. November	12. December
21. Winter	22. Spring	23. Summer	24. Fall		

G88K3YR. [CYNAMF CYNAML], [CYAQRTH], [AGEIWDATE] [G88H2]

(In what month and year did [you / he / she] receive [your / his / her] highest degree?)

The month entered is: [G88K3MO]

- ENTER the year below

1920 – [CYEAR]

G88LCKPT. CAI Checkpoint: Where OFUM Educated

1. Outside U.S. (G88A=2, 3)	3. U.S. Only (G88A=1, DK)	5. All Others (G88A=5, RF)
↓	GO TO G88M2CKPT	GO TO G90A RULE

G88L. [CYNAMF CYNAML], [CYAQRTH], [AGEIWDAT]E

How many years of school did [you / she / he] complete outside of the U.S.?

1 – 25

G88M1. [CYNAMF CYNAML], [CYAQRTH], [AGEIWDAT]E

What was the highest degree or certificate [you / she / he] earned outside the U.S.?

String 100

G88M2CKPT. CAI Checkpoint: Whether OFUM Still in School

1. Still in School (G88F2MO=96 or G88F2YR=9996)	→ GO TO G88M3	5. All Others
		↓

G88M2. [CYNAMF CYNAML], [CYAQRTH], [AGEIWDAT]E

[Are you / Is [he / she]] currently attending or enrolled in regular school? Regular school includes high school and schooling that leads to a college or professional school degree.

1. Yes 5. No → GO TO G90A RULE

↓

G88M3. [CYNAMF CYNAML], [CYAQRTH], [AGEIWDAT]E

[G88M2CKPT=STILL IN SCHOOL: Earlier you said [you are / CYNAMF is] still in school.]

What grade or year [are you / is [he / she]] currently attending?

1. First grade	2. Second grade	3. Third grade	4. Fourth grade	5. Fifth grade
6. Sixth grade	7. Seventh grade	8. Eighth grade	9. Ninth grade	10. Tenth grade
11. Eleventh grade		12. Twelfth grade, "High School", GED		
13. 1st year college (freshman)		14. 2nd year college (sophomore)		
15. 3rd year college (junior)		16. 4th year college (senior)		
17. 5th year or higher of college		18. Post-graduate work		

GO TO G90A RULE

END G88AG88M3

Education - Returning Big OFUM Age 16-49

SECTION_G.G73_G90 [1-24].G88NG88DD [1-24]=AQSN of FU Member

G88N. [CYNAMF CYNAML], [CYAQRTH], [AGEIWDAT]E

Now I would like to talk about the education [you have / [CYNAMF CYNAML] has] received.

[Have you / Has [CYNAMF CYNAML]] attended regular school since our last interview on [PYIWDAT]E]? Regular school includes high school and schooling that leads to a college or professional school degree.

- ENTER [2] for "still in school"

1. Yes	2. Still in school (IF VOL)	5. No	DK/RF
	↓	GO TO G88CCCKPT	

G88O. [CYNAMF CYNAML], [CYAQRTH], [AGEIWDATE]

Where did [you / [CYNAMF CYNAML]] receive [your / her / his] education — in the United States, outside the United States, or both?

- **If needed:** Between our last interview on [PYIWDATE] and now

1. United States only	2. Outside U.S. only	3. Both in U.S. and outside	DK	RF	→ GO TO G88AACKPT
↓	GO TO G88AACKPT	↓			

G88P1CKPT. CAI Checkpoint: Whether Preloaded Education Level is Less Than HS Grad/GED or Non-Response

1. <HS Grad/GED (PYPERSINFO.COMPEDUC=0-11, NA)	5. All Others	→ GO TO G88T1
↓		

G88P1. [CYNAMF CYNAML], [CYAQRTH], [AGEIWDATE]

(Since our last interview on [PYIWDATE],) did [you / he / she] graduate from high school, get a GED, or neither?

- **ENTER [3] if R says OFUM is still in school (attending grade 1-12) or working on a GED**

1. Graduated from high school	2. Got a GED	3. Neither	DK/RF
↓	GO TO G88Q1	GO TO G88S1	GO TO G88T1

G88P2MO. [CYNAMF CYNAML], [CYAQRTH], [AGEIWDATE]

In what month and year did [you / he / she] graduate?

- **If needed:** Between our last interview on [PYIWDATE] and now
- **SELECT Month and [Enter] to go to next screen for year**
- **IF NECESSARY:** What would be your best estimate?

1. January	2. February	3. March	4. April	5. May	6. June
7. July	8. August	9. September	10. October	11. November	12. December
21. Winter	22. Spring	23. Summer	24. Fall		

G88P2YR. [CYNAMF CYNAML], [CYAQRTH], [AGEIWDATE]

(In what year did [you / she / he] graduate?)

- **If needed:** Between our last interview on [PYIWDATE] and now
- **The month entered is:** [G88P2MO]
- **ENTER the year below**

1920 – [CYEAR]	→GO TO G88T1
----------------	--------------

CHECK for G88P2YR<P2YEAR: IWER: All years prior to [P2YEAR] are not allowed since we are asking about education since [PYIWDATE]. Please VERIFY Year graduated High School since [PYIWDATE]: If R confirms the year is before [P2YEAR], then SELECT GoTo to go back to G88N and ENTER [5]. If R gives a year from [P2YEAR] to [CYEAR], then SELECT Close and ENTER [Year].

G88Q1. [CYNAMF CYNAML], [CYAQRTH], [AGEIWDAT]E]

How many grades of regular school did [you / he / she] finish prior to getting [your / her / his] GED?

- Record last grade finished prior to receiving GED
- If needed: Regular school includes high school and schooling that leads to a college or professional school degree.

0. None	1. First grade	2. Second grade	3. Third grade
GO TO	4. Fourth grade	5. Fifth grade	6. Sixth grade
G88R1MO	7. Seventh grade	8. Eighth grade	9. Ninth grade
	10. Tenth grade	11. Eleventh grade	DK/RF → GO TO G88R1MO



G88Q2MO. [CYNAMF CYNAML], [CYAQRTH], [AGEIWDAT]E]

In what month and year did [you / she / he] last attend [G88Q]?

- SELECT Month and [Enter] to go to next screen for year
- IF NECESSARY: What would be your best estimate?

1. January	2. February	3. March	4. April	5. May	6. June
7. July	8. August	9. September	10. October	11. November	12. December
21. Winter	22. Spring	23. Summer	24. Fall		

G88QY2R. [CYNAMF CYNAML], [CYAQRTH], [AGEIWDAT]E]

(In what month and year did [you / she / he] last attend [G88Q]?)

The month entered is: [G88Q2MO]

- ENTER the year below

1920 – [CYEAR]

G88R1MO. [CYNAMF CYNAML], [CYAQRTH], [AGEIWDAT]E]

In what month and year did [you / she / he] receive [your / her / his] GED?

- If needed: Between our last interview on [PYIWDAT]E] and now
- SELECT Month and [Enter] to go to next screen for year
- IF NECESSARY: What would be your best estimate?

1. January	2. February	3. March	4. April	5. May	6. June
7. July	8. August	9. September	10. October	11. November	12. December
21. Winter	22. Spring	23. Summer	24. Fall		

G88R1YR. [CYNAMF CYNAML], [CYAQRTH], [AGEIWDAT]E]

(In what month and year did [you / she / he] receive [your / her / his] GED?)

- If needed: Between our last interview on [PYIWDAT]E] and now

The month entered is: [G88R1MO]

- ENTER the year below

1920 – [CYEAR] → GO TO G88T1

CHECK for G88R1YR < P2YEAR: IWER: All years prior to [P2YEAR] are not allowed since we are asking about education since [PYIWDAT]E]. Please VERIFY Year received GED since [PYIWDAT]E]: If R confirms the year is before [P2YEAR], then SELECT GoTo to go back to G88N and ENTER [5]. If R gives a year from [P2YEAR] to [CYEAR], then SELECT Close and ENTER [Year].

G88S1. [CYNAMF CYNAML], [CYAQRTH], [AGEIWDAT]

How many grades of regular school did [you / she / he] finish?

- Record last grade finished
- If needed: Regular school includes high school and schooling that leads to a college or professional school degree.

0. None	1. First grade	2. Second grade	3. Third grade
GO TO	4. Fourth grade	5. Fifth grade	6. Sixth grade
G88T1	7. Seventh grade	8. Eighth grade	9. Ninth grade
	10. Tenth grade	11. Eleventh grade	DK/RF → GO TO G88T1



G88S2MO. [CYNAMF CYNAML], [CYAQRTH], [AGEIWDAT]

In what month and what year did [you / she / he] last attend [G88S]?

- SELECT Month and [Enter] to go to next screen for year
- IF NECESSARY: What would be your best estimate?

1. January	2. February	3. March	4. April	5. May	6. June
7. July	8. August	9. September	10. October	11. November	12. December
21. Winter	22. Spring	23. Summer	24. Fall		

G88S2YR. [CYNAMF CYNAML], [CYAQRTH], [AGEIWDAT]

(In what month and what year did [you / she / he] last attend [G88S]?)

The month entered is: [G882SMO]

- ENTER the year below

1920 – [CYEAR]

G88T1. [CYNAMF CYNAML], [CYAQRTH], [AGEIWDAT]

Did [you / she / he] attend college between [PYIWDAT] and now?

1. Yes	5. No	→ GO TO G88VCKPT
--------	-------	------------------



CHECK for G88T1=NO, DK/RF & PYPERSINFO.COMPEDUC=12-17: IWER: R reported that [CYNAMF CYNAML] attended school since [PYIWDAT], and we know from previous waves that [CYNAMF CYNAML] has already graduated high school or received a GED. Please VERIFY with whether this person attended college since [PYIWDAT]: If R says NO or DK/RF, then SELECT GoTo to go back to G88N and ENTER [5] or [DK, RF]. If R says YES, then SELECT Close and ENTER [1].

G88T2MO. [CYNAMF CYNAML], [CYAQRTH], [AGEIWDAT]

In what month and year did [you / she / he] last attend college?

- If needed: Between our last interview on [PYIWDAT] and now
- If still in school, ENTER [96] for month
- SELECT Month and [Enter] to go to next screen for year
- NECESSARY: What would be your best estimate?

1. January	2. February	3. March	4. April		
5. May	6. June	7. July	8. August		
9. September	10. October	11. November	12. December		
21. Winter	22. Spring	23. Summer	24. Fall	DK/RF	96. Still in school



GO TO G88VCKPT

G88T2YR. [CYNAMF CYNAML], [CYAQRTH], [AGEIWDATE]

(In what month and year did [you / she / he] last attend college?)

- **If needed:** Between our last interview on [PYIWDATE] and now
The month entered is: [G88T2MO]
- ENTER the year below
9996 If still in school

1920 – [CYEAR] 9996. Still in school

CHECK for G88T2YR<P2YEAR: IWER: All years prior to [P2YEAR] are not allowed since we are asking about education since [PYIWDATE]. Please VERIFY Year last attended college since [PYIWDATE]: If R confirms the year is before [P2YEAR], then SELECT GoTo to go back to G88N and ENTER [5]. If R gives a year from [P2YEAR] to [CYEAR], then SELECT Close and ENTER [Year].

G88VCKPT. CAI Checkpoint: Whether OFUM Attended College since Last Wave

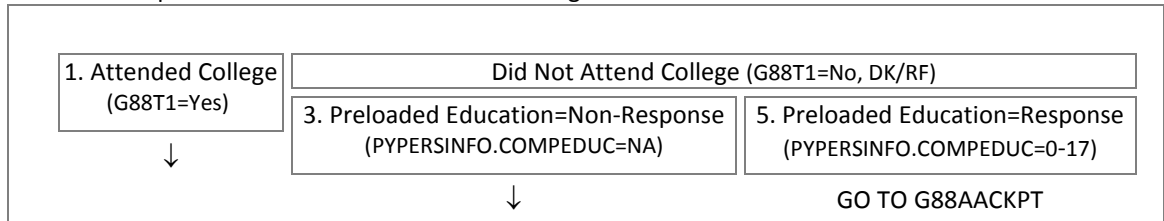

G88V. [CYNAMF CYNAML], [CYAQRTH], [AGEIWDATE]

Altogether, what is the highest year of college [you have / [he / she] has] completed?

- **IF R gives a degree:** How many years of college [have you / has [she / he]] completed altogether? We'll talk about any college degrees [you have / [he / she] has] earned next.
- [G88VCKPT=3: ENTER [0] if R says None or Never attended college]

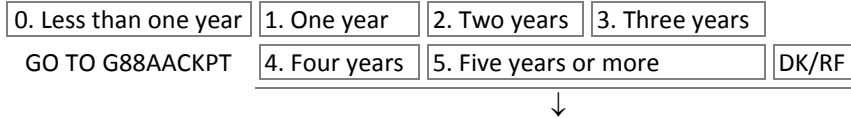

G88WCKPT. CAI Checkpoint: Whether OFUM Attended College since Last Wave

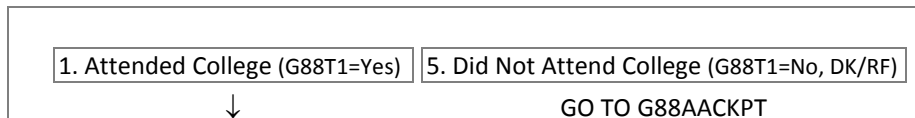

G88W. [CYNAMF CYNAML], [CYAQRTH], [AGEIWDATE]

Did [you / she / he] receive a college degree between [PYIWDATE] and now?

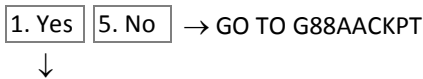

G88X1. [CYNAMF CYNAML], [CYAQRTH], [AGEIWDAT]E

(Since our last interview on [PYIWDAT]E,) what college degree did [you / [he / she]] receive?

- **If needed:** Between our last interview on [PYIWDAT]E and now
- **If more than one degree,** PROBE for the **highest** degree received since [PYIWDAT]E

1. Associate's degree/AA	3. Master's degree/MA/MS/MBA
2. Bachelor's degree/BA/BS	4. Doctorate/PhD
	5. LLB, JD (Law degrees)
	6. MD, DDS, DVM, DO (Medical degrees)
	8. Honorary degree
	97. Other-specify (G88X1SPEC. Specify (String 100))

DK/RF

GO TO G88Y



G88X2. [CYNAMF CYNAML], [CYAQRTH], [AGEIWDAT]E

What was [your / her / his] major or majors at the college or university from which [you / he / she] received [your / his / her] bachelor's degree?

- **Probe for details and dual majors**

String 100

G88X3. [CYNAMF CYNAML], [CYAQRTH], [AGEIWDAT]E

What was the name of the college or university?

- **If needed:** What was the name of the college or university from which [you / she / he] received [your / her / his] bachelor's degree?

String 100

G88X4CITY. [CYNAMF CYNAML], [CYAQRTH], [AGEIWDAT]E

Where was it located?

- **If needed:** In what city and state was the college or university from which [you / she / he] received [your / her / his] bachelor's degree?

String 100

G88X4STATE. [CYNAMF CYNAML], [CYAQRTH], [AGEIWDAT]E

(Where was it located?)

- **If needed:** In what state is the college or university from which [you / she / he] received [your / her / his] bachelor's degree?
- **Start typing the name of the State to bring up the look-up list**
- **IF foreign country, ENTER [FOR] to select "Foreign Country"**

String 30; U.S. State → GO TO Foreign Country DK/RF → GO TO
G88X5MO ↓ G88X5MO

G88X4COUNTRY. [CYNAMF CYNAML], [CYAQRTH], [AGEIWDAT]E

(Where was it located?)

- **If needed:** In what country is the college or university from which [you / he / she] received [your / his / her] bachelor's degree?
- **Start typing the name of the Foreign Country to bring up the look-up list**

String 30; Country

G88X5MO. [CYNAMF CYNAML], [CYAQRTH], [AGEIWDATE]

In what month and year did [you / she / he] receive [your / his / her] bachelor's degree?

- **SELECT** Month and [Enter] to go to next screen for year
- **IF NECESSARY:** What would be your best estimate?

1. January	2. February	3. March	4. April
5. May	6. June	7. July	8. August
9. September	10. October	11. November	12. December
21. Winter	22. Spring	23. Summer	24. Fall

G88X5YR. [CYNAMF CYNAML], [CYAQRTH], [AGEIWDATE]

(In what month and year did [you / she / he] receive [your / his / her] bachelor's degree)?

The month entered is: [G88X_4MO]

- **ENTER** the year below

1920 – [CYEAR]

G88Y. [CYNAMF CYNAML], [CYAQRTH], [AGEIWDATE] [G88X1]

(And) What was [your / her / his] [G88X1=BACHELORS: major or majors / ALL OTHERS: area of study] at the college or university from which [you / he / she] received [your / his / her] highest degree since our last interview on [PYIWDATE]?

- **Probe for details and dual majors**

String 100

G88Z1. [CYNAMF CYNAML], [CYAQRTH], [AGEIWDATE] [G88X1]

What was the name of the college or university?

- **If needed:** What was the name of the college or university from which [you / she / he] received [your / her / his] highest degree (since our last interview on [PYIWDATE])?

String 100

G88Z2CITY. [CYNAMF CYNAML], [CYAQRTH], [AGEIWDATE] [G88X1]

Where was it located?

- **If needed:** In what city and state was the college or university from which [you / she / he] received [your / her / his] highest degree (since our last interview on [PYIWDATE])?

String 100

G88Z2STATE. [CYNAMF CYNAML], [CYAQRTH], [AGEIWDATE] [G88X1]

(Where was it located?)

- **If needed:** In what state is the college or university from which [you / she / he] received [your / her / his] highest degree (since our last interview on [PYIWDATE])?
- **Start typing the name of the State to bring up the look-up list**
- **IF foreign country, ENTER [FOR] to select "Foreign Country"**

String 30; U.S. State → GO TO G88Z3MO Foreign Country DK/RF → GO TO G88Z3MO



G88Z2COUNTRY. [CYNAMF CYNAML], [CYAQRTH], [AGEIWDATE] [G88X1]

(Where was it located?)

- **If needed:** In what country is the college or university from which [you / he / she] received [your / his / her] highest degree (since our last interview on [PYIWDATE])?
- **Start typing the name of the Foreign Country to bring up the look-up list**

String 30; Country

G88Z3MO. [CYNAMF CYNAML], [CYAQRTH], [AGEIWDATE] [G88X1]

In what month and year did [you / she / he] receive [your / her / his] highest degree?

- **If needed:** Between our last interview on [PYIWDATE] and now
- **SELECT** Month and [Enter] to go to next screen for year
- **IF NECESSARY:** What would be your best estimate?

1. January	2. February	3. March	4. April	5. May	6. June
7. July	8. August	9. September	10. October	11. November	12. December
21. Winter	22. Spring	23. Summer	24. Fall		

G88Z3YR. [CYNAMF CYNAML], [CYAQRTH], [AGEIWDATE] [G88X1]

(In what month and year did [you / she / he] receive [your / her / his] highest degree?)

- **If needed:** Between our last interview on [PYIWDATE] and now
- **The month entered is:** [G88Z3MO]
- **ENTER** the year below

1920 – [CYEAR]

CHECK for G88Z3YR < P2YEAR: IWER: All years prior to [P2YEAR] are not allowed since we are asking about education since [PYIWDATE]. Please VERIFY Year received highest degree since [PYIWDATE]. If R confirms the year is before [P2YEAR], then SELECT GoTo to go back to G88N and ENTER [5]. If R gives a year from [P2YEAR] to [CYEAR], then SELECT Close and ENTER [Year].

G88AACKPT. CAI Checkpoint: Where OFUM Educated

1. Outside U.S. (G88O = 2, 3)	3. U.S. Only (G88O=1, DK)	5. All Others (G88O=RF)	→ GO TO G90A RULE
↓	GO TO G88CCCKPT		

G88AA. [CYNAMF CYNAML], [CYAQRTH], [AGEIWDATE]

Between [PYIWDATE] and now, how many years of school did [you / she / he] complete outside of the U.S.?

1 – 3

G88BB. [CYNAMF CYNAML], [CYAQRTH], [AGEIWDATE]

(Between [PYIWDATE] and now,) what was the highest degree or certificate [you / she / he] earned outside the U.S.?

String 100

G88CCCKPT. CAI Checkpoint: Whether OFUM Still in School

1. Still in School (G88N=2 or G88T2MO=96 or G88T2YR=9996)	→ GO TO G88DD	5. All Others
		↓

G88CC. [CYNAMF CYNAML], [CYAQRTH], [AGEIWDATE]

[Are you / Is [he / she]] currently attending or enrolled in regular school? (Regular school includes high school and schooling that leads to a college or professional school degree.)

1. Yes 5. No → GO TO G90A RULE



G88DD. [CYNAMF CYNAML], [CYAQRTH], [AGEIWDATE]

[G88CCCKPT=STILL IN SCHOOL: Earlier you said [you are / CYNAMF is] still in school.]

What grade or year [are you / is [he / she]] currently attending?

1. First grade	2. Second grade	3. Third grade	4. Fourth grade	5. Fifth grade
6. Sixth grade	7. Seventh grade	8. Eighth grade	9. Ninth grade	10. Tenth grade
11. Eleventh grade		12. Twelfth grade, "High School", GED		
13. 1st year college (freshman)		14. 2nd year college (sophomore)		
15. 3rd year college (junior)		16. 4th year college (senior)		
17. 5th year or higher of college		18. Post-graduate work		

GO TO G90A RULE

END G88NG88DD

G90A Rule: Whether There are More Big OFUMs

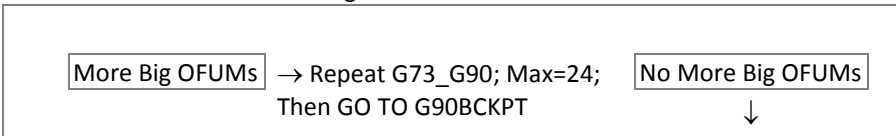

END G73_G90

PYear Income - Little OFUM Age 15 or Younger

G90BCKPT [1-24]. CAI Checkpoint: Section G Little OFUM Qualifier ([1-24]= AQSN of FU Member)

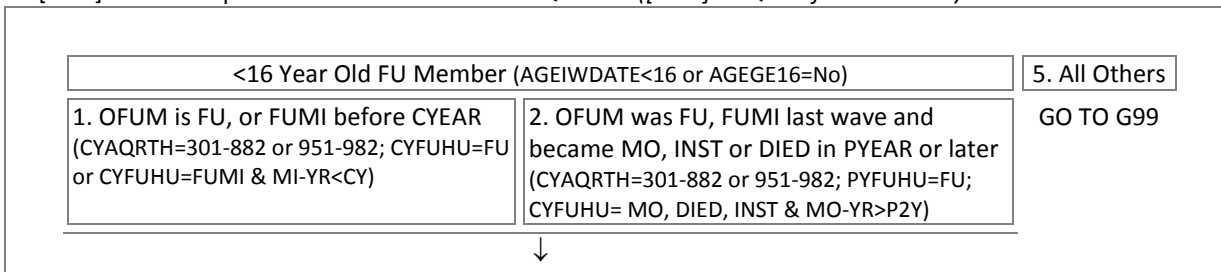

SECTION_G.G90D_G97 [1-24] [1-24]=AQSN of FU Member

G90D. [CYNAMF CYNAML], [CYAQRTH], [AGEIWDATE]

[LOOP 1: Now the younger member(s) of your family.]

Did [CYNAMF CYNAML] have any income in [PYEAR]?

1. Yes 5. No → GO TO G98 RULE



G92. [CYNAMF CYNAML], [CYAQRTH], [AGEIWDAT]

Now, we would like to ask about [CYNAMF CYNAML's] income. What was that from?

- ENTER all that apply
- PROBE: Any others?
- SSI (Supplemental Security Income) is **not** Social Security, nor is it Social Security Disability Insurance (SSDI), although the Social Security Administration administers the program and a person can receive both. See F1-Help for more information.

1. Work	2. Interest	3. SSI	4. Welfare	5. Social Security	6. Other-specify	DK/RF	→ GO TO G98 RULE
---------	-------------	--------	------------	--------------------	------------------	-------	---------------------

G92=Work

G94A. [CYNAMF CYNAML], [CYAQRTH], [AGEIWDAT]

How much was from work?

- ENTER amount here, then SELECT unit of time on next screen (Hour, Week, Two weeks, Month, Year)

\$ 1.0 – 9,999,997.99	DK/RF	→ GO TO G94AA
-----------------------	-------	---------------



G94APER. The amount entered is: [G94A] per _____

- SELECT the unit of time below

1. Hour	3. Week	4. Two weeks	5. Month	6. Year
7. Other-specify (G94APERSPEC. Specify. (String 100))				

G94AA. [CYNAMF CYNAML], [CYAQRTH], [AGEIWDAT]

During which months of [PYEAR] did [he / she] get this income?

- ENTER all that apply
- PROBE: Any others?

1. January	2. February	3. March	4. April	5. May	6. June	
7. July	8. August	9. September	10. October	11. November	12. December	13. All

G95. [CYNAMF CYNAML], [CYAQRTH], [AGEIWDAT]

What was [his / her] occupation? What kind of work did [he / she] do?

- DO NOT PROBE

String 500

G96. [CYNAMF CYNAML], [CYAQRTH], [AGEIWDAT]

About how many weeks did [he / she] work on that job last year ([PYEAR])?

1 – 52

G97. [CYNAMF CYNAML], [CYAQRTH], [AGEIWDAT]

During the weeks that [he / she] worked, about how many hours did [he / she] usually work per week?

- ROUND DOWN for fractions less than ½ (0.5)
- ROUND UP for fractions ½ (0.5) or more

1 – 112

G92=Interest

G94B. [CYNAMF CYNAML], [CYAQRTH], [AGEIWDAT]

How much was from interest?

- ENTER amount here, then SELECT unit of time on next screen (Month, Year)

\$ 1 – 999,997	DK/RF	→ GO TO G94BB
----------------	-------	---------------



G94BPER. The amount entered is: [G94B] per ____

- SELECT the unit of time below

5. Month 6. Year 7. Other-specify (G94BPERSPEC. Specify. (String 100))

G94BB. [CYNAMF CYNAML], [CYAQRTH], [AGEIWDATE]

During which months of [PYEAR] did [he / she] get this income?

- ENTER all that apply
- PROBE: Any others?

1. January 2. February 3. March 4. April 5. May 6. June
7. July 8. August 9. September 10. October 11. November 12. December 13. All

G92=SSI

G94C. [CYNAMF CYNAML], [CYAQRTH], [AGEIWDATE]

How much was from SSI?

- ENTER amount here, then SELECT unit of time on next screen (Month, Year)
- SSI (Supplemental Security Income) is **not** Social Security, nor is it Social Security Disability Insurance (SSDI), although the Social Security Administration administers the program and a person can receive both. See F1-Help for more information.

\$ 1 – 999,997 DK/RF → GO TO G94CC



G94CPER. The amount entered is: [G94C] per ____

- SELECT the unit of time below

5. Month 6. Year 7. Other-specify (G94CPERSPEC. Specify. (String 100))

G94CC. [CYNAMF CYNAML], [CYAQRTH], [AGEIWDATE]

During which months of [PYEAR] did [he / she] get this income?

- ENTER all that apply
- PROBE: Any others?

1. January 2. February 3. March 4. April 5. May 6. June
7. July 8. August 9. September 10. October 11. November 12. December 13. All

G92=Welfare

G94D. [CYNAMF CYNAML], [CYAQRTH], [AGEIWDATE]

How much was from welfare?

- ENTER amount here, then SELECT unit of time on next screen (Week, Two weeks, Month, Year)

\$ 1 – 999,997 DK/RF → GO TO G94DD



G94DPER. The amount entered is: [G94D] per ____

- SELECT the unit of time below

3. Week 4. Two weeks 5. Month 6. Year
7. Other-specify (G94DPERSPEC. Specify. (String 100))

G94DD. [CYNAMF CYNAML], [CYAQRTH], [AGEIWDAT]E

During which months of [PYEAR] did [he / she] get this income?

- ENTER all that apply
- PROBE: Any others?

1. January	2. February	3. March	4. April	5. May	6. June	
7. July	8. August	9. September	10. October	11. November	12. December	13. All

G92=Social Security

G94ECKPT. CAI Checkpoint: Whether Social Security Already Reported For This OFUM at G32

1. Not Reported	5. Already Reported	→ GO TO Next G94 Item; or G98 RULE
↓		

G94E2A. [CYNAMF CYNAML], [CYAQRTH], [AGEIWDAT]E

What was the Social Security? Was that survivor's benefits, dependent assistance, or what?

- ENTER all that apply
- PROBE: Any others?

3. Survivors benefits	5. Dependent of disabled recipient
6. Dependent of retired recipient	7. Other-specify (G94E2ASPEC. Specify. (String 100))

G94E3. [CYNAMF CYNAML], [CYAQRTH], [AGEIWDAT]E

How much was the total amount from Social Security? [2+ SOCSEC INCOMES: Please include all amounts from all types of Social Security [you / he / she] received in [PYEAR].]

- ENTER amount here, then SELECT unit of time on next screen (Month, Year)

\$ 1 – 999,997	DK/RF	→ GO TO G94E4
----------------	-------	---------------

↓

G94E3PER. The amount entered is: [G94E3] per ____

- SELECT the unit of time below

5. Month	6. Year	7. Other-specify (G94E3PERSPEC. Specify. (String 100))
----------	---------	--

G94E4. [CYNAMF CYNAML], [CYAQRTH], [AGEIWDAT]E

During which months of [PYEAR] did [you / he / she] get this income? [(This includes all types of Social Security [you / he / she] received in [PYEAR].)]

- ENTER all that apply
- PROBE: Any others?

1. January	2. February	3. March	4. April	5. May	6. June	
7. July	8. August	9. September	10. October	11. November	12. December	13. All

G92=Other

G94F. [CYNAMF CYNAML], [CYAQRTH], [AGEIWDAT]

What was that other income from?

- DO NOT include gifts, allowances, or other money from other FU members
- IF R mentions income from a job, PROBE for these details:
- Occ/Ind: What was [his / her] occupation? What sort of work did [he / she] do? (DO NOT PROBE)
- Start/End: What month and year did [he / she] start that job? End that job?
- Work Hours: How many weeks did [he / she] work at that job in [PYEAR]? On average, how many hours per week did [he / she] work in [PYEAR]?
- To SAVE your entry, use Alt-S

Open End

G94F2. [CYNAMF CYNAML], [CYAQRTH], [AGEIWDAT]

How much was it?

- ENTER amount here, then SELECT unit of time on next screen (Week, Two weeks, Month, Year)

\$ 1 – 999,997 DK/RF → GO TO G94F3

↓

G94F2PER. The amount entered is: [G94F2] per ____

- SELECT the unit of time below

3. Week 4. Two weeks 5. Month 6. Year

7. Other-specify (G94F2PERSPEC. Specify. (String 100))

G94F3. [CYNAMF CYNAML], [CYAQRTH], [AGEIWDAT]

During which months of [PYEAR] did [he / she] get this income?

- ENTER all that apply
- PROBE: Any others?

1. January	2. February	3. March	4. April	5. May	6. June	
7. July	8. August	9. September	10. October	11. November	12. December	13. All

G98 Rule: Whether There are More Little OFUMs

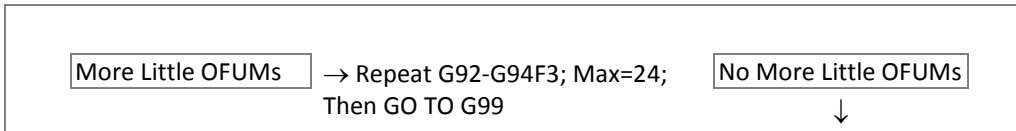

END G90D_G97

PYear Settlements, Deductions, and Support of Others

G99. Did [you / [RP]] [or anyone else in [your / his / her] family living there] get any other money in [PYEAR] - like a big settlement from an insurance company, or an inheritance?

1. Yes 5. No → GO TO G102

↓

G100. How much did that amount to?

\$ 1 – 9,999,997

G101. How much of that was an inheritance?

\$ 0 – 9,999,997

G102. Some people have expenses they can itemize and deduct on their income tax. Did [R= RP, SP: you / R=OFUM, PROXY: [RP] SP IN FU: and [SP]] itemize deductions on [R= RP, SP: your / R=OFUM, PROXY: [his / her / SP IN FU: their]] [PYEAR] federal income tax, such as property taxes, interest payments, medical expenses, and charitable contributions?

1. Yes 5. No or did / will not file → GO TO G103



G102A. How much was [your / his / her] itemized deduction for charitable contributions?

\$ 0 – 999,997

G102B. How much was [your / his / her] itemized deduction for medical expenses?

- **IF necessary:** Is that the amount of the deduction or is that the total medical expenses? What was the amount of the deduction?

\$ 0 – 999,997

G103. In [PYEAR], did [you / [RP]] [or anyone else in [your / his / her] family living there] give any money toward the support of anyone who was not living there at the time, including child support, alimony, money given to parents, and things like that? Don't include loans or charitable contributions to organizations; we'll ask about them later.

1. Yes 5. No → GO TO SECTION W



G104. How many people was that?

1 – 9 DK/RF → GO TO G106



SECTION_G.G105.G105PEOPLE [1-24] [1-24]=Which person

FIRSTNAME. What is the [first / next] person's first and last name?

- **ENTER First name**

String 10

LASTNAME. (What is the [first / next] person's first and last name?)

- **ENTER Last name**

String 15

G105RTHLAB. What is [G105FIRSTNAME G105LASTNAME]'s relationship to [you / [RP]]?

- **ENTER person's relationship to Reference Person**

101. Husband	102. Female Reference Person		
151. Ex-Male Spouse (Ex-Husband)	152. Ex-Female Spouse (Ex-Wife)		
181. Deceased Male Spouse	182. Deceased Female Spouse		
201. Male Spouse	202. Female Spouse	221. Male Partner	222. Female Partner
301. Son	302. Daughter	331. Stepson	332. Stepdaughter
351. Son of Partner	352. Daughter of Partner	371. Son-in-law	372. Daughter-in-law
381. Foster son	382. Foster daughter	401. Brother	402. Sister
471. Brother-in-law	472. Sister-in-law	481. Brother of Partner/Boyfriend/Girlfriend	
482. Sister of Partner/Boyfriend/Girlfriend		501. Father	502. Mother
571. Father-in-law	572. Mother-in-law	581. Father of Partner/Boyfriend/Girlfriend	
582. Mother of Partner/Boyfriend/Girlfriend		601. Grandson	602. Granddaughter
661. Grandfather	662. Grandmother	671. Grandfather of Spouse	

672. Grandmother of Spouse	681. Great-Grandfather	
682. Great-Grandmother	691. Great-Grandfather of Spouse	
692. Great-Grandmother of Spouse	701. Nephew of Reference Person	
702. Niece of Reference Person	711. Nephew of Spouse	
712. Niece of Spouse	721. Uncle of Reference Person	
722. Aunt of Reference Person	731. Uncle of Spouse	
732. Aunt of Spouse	741. Cousin of Reference Person-Male	
742. Cousin of Reference Person-Female	751. Cousin of Spouse -Male	
752. Cousin of Spouse -Female	831. Son of Boyfriend/Girlfriend	
832. Daughter of Boyfriend/Girlfriend	881. Boyfriend	882. Girlfriend
901. Uncooperative Male Spouse	902. Uncooperative Female Spouse	
921. Uncooperative Male Partner	922. Uncooperative Female Partner	
951. Relative of Reference Person-Male	952. Relative of Reference Person-Female	
961. Relative of Spouse-Male	962. Relative of Spouse-Female	
971. Relative of Partner/Boyfriend/Girlfriend-Male		
972. Relative of Partner/Boyfriend/Girlfriend-Female		
981. Friend/Non-Relative-Male	982. Friend/Non-Relative-Female	

END G105PEOPLE

G106 Rule: Whether More People Reported at G104

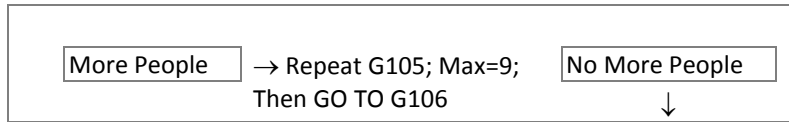

G106. How much money was that altogether in [PYEAR]?

\$ 1 – 9,999,997

G107. Was any of that child support?

1. Yes 5. No → GO TO G109



G108. How much did that child support amount to in [PYEAR]?

\$ 1 – [G106 / 9,999,997]

G109. Was any of the money [you / [RP]] gave in [PYEAR] alimony?

1. Yes 5. No → GO TO G111 RULE



G110. How much did that alimony amount to in [PYEAR]?

\$ 1 – [G106 / 9,999.997]

G111 Rule: Number of People Reported at G104



G112. Were any of those people dependent on [you / [RP]] for more than half of their total support?

1. Yes 5. No → GO TO SECTION W

↓

G113. How many people was that?

1 - 9 → GO TO SECTION W

G114. Was that person dependent on [you / [RP]] for more than half of their total support?

1. Yes 5. No

GO TO SECTION W

END SECTION_G

Section W: Wealth and Active Savings

[TOC](#)

SECTION_W

Other Real Estate

W1. The next questions I will be asking are designed to give estimates of the wealth of families. [*R=RP, SP, OFUM*: In these questions when I refer to the family, I mean your family living there with you.]

Do you [or your family living there] have any real estate [*A19=OWNS*: other than your main home,] such as a second home, land (not including farmland), rental real estate, or money owed to you on a land contract?

1. Yes 5. No → GO TO W6



W1A. Does that include a second home?

1. Yes 5. No

W2A. How much is the real estate worth, that is, how much would it sell for?

- **If needed:** Real estate [*A19=OWNS*: other than your main home,] such as a second home, land (not including farmland), rental real estate, or money owed to you on a land contract

\$ 0 – 999,999,997 → GO TO W2B DK/RF



W3A. Would it amount to \$50,000 or more?	
<input type="checkbox"/> 1. Yes	<input type="checkbox"/> 5. No <input type="checkbox"/> DK/RF → GO TO W2B
↓	↓
W4A. \$175,000 or more?	W5A. \$20,000 or more?
<input type="checkbox"/> 1. Yes <input type="checkbox"/> 5. No <input type="checkbox"/> DK/RF	<input type="checkbox"/> 1. Yes <input type="checkbox"/> 5. No <input type="checkbox"/> DK/RF

W2B. (And) how much debt do you owe on that (real estate)?

- **If needed:** Real estate [*A19=OWNS*: other than your main home,] such as a second home, land (not including farmland), rental real estate, or money owed to you on a land contract

\$ 0 – 999,999,997 → GO TO W6 DK/RF



W3B. Would it amount to \$50,000 or more?	
<input type="checkbox"/> 1. Yes	<input type="checkbox"/> 5. No <input type="checkbox"/> DK/RF → GO TO W6
↓	↓
W4B. \$175,000 or more?	W5B. \$20,000 or more?
<input type="checkbox"/> 1. Yes <input type="checkbox"/> 5. No <input type="checkbox"/> DK/RF	<input type="checkbox"/> 1. Yes <input type="checkbox"/> 5. No <input type="checkbox"/> DK/RF

Personal Vehicles

W6. What about the value of what you [or anyone in your family living there] own on wheels? Including [F47=YES: personal vehicles you may have already told me about and] any cars, trucks, a motor home, a trailer, or a boat - what are they worth all together, minus anything you still owe on them?

- Include only vehicles owned by the FU
- DO NOT include vehicles owned by HU or HUCS people

→ GO TO W10



W7. Would they amount to \$10,000 or more?					
<input type="text" value="1. Yes"/>		<input type="text" value="5. No"/> <input type="text" value="DK/RF"/> → GO TO W10			
↓			↓		
W8. \$25,000 or more?			W9. \$2,000 or more?		
<input type="text" value="1. Yes"/>	<input type="text" value="5. No"/>	<input type="text" value="DK/RF"/>	<input type="text" value="1. Yes"/>	<input type="text" value="5. No"/>	<input type="text" value="DK/RF"/>

Farm or Business

W10. Do you [or anyone in your family living there] currently own part or all of a farm or business?

→ GO TO W15



W11A. How much is your part (of the farm or business) worth, that is, how much would it sell for?

→ GO TO W11B



W12A. Would it amount to \$50,000 or more?					
<input type="text" value="1. Yes"/>		<input type="text" value="5. No"/> <input type="text" value="DK/RF"/> → GO TO W11B			
↓			↓		
W13A. \$200,000 or more?			W14A. \$10,000 or more?		
<input type="text" value="1. Yes"/>	<input type="text" value="5. No"/>	<input type="text" value="DK/RF"/>	<input type="text" value="1. Yes"/>	<input type="text" value="5. No"/>	<input type="text" value="DK/RF"/>

W11B. And how much debt do you owe on that (farm or business)?

→ GO TO W15



W12B. Would it amount to \$50,000 or more?					
<input type="text" value="1. Yes"/>		<input type="text" value="5. No"/> <input type="text" value="DK/RF"/> → GO TO W15			
↓			↓		
W13B. \$200,000 or more?			W14B. \$10,000 or more?		
<input type="text" value="1. Yes"/>	<input type="text" value="5. No"/>	<input type="text" value="DK/RF"/>	<input type="text" value="1. Yes"/>	<input type="text" value="5. No"/>	<input type="text" value="DK/RF"/>

Stocks

W15. (Do you [or anyone in your family living there] have...)

Any shares of stock in publicly held corporations, stock mutual funds, or investment trusts, not including stocks in retirement accounts?

1. Yes 5. No → GO TO W21



W16. If you sold all that and paid off anything you owed on it, how much would you have?

→ GO TO W20CCKPT



W17. Would it amount to \$50,000 or more?	
<input type="checkbox"/> 1. Yes	<input type="checkbox"/> 5. No <input type="text" value="DK/RF"/> → GO TO W20CCKPT
↓	↓
W20. \$150,000 or more?	W19. \$15,000 or more?
<input type="checkbox"/> 1. Yes <input type="checkbox"/> 5. No <input type="text" value="DK/RF"/>	<input type="checkbox"/> 1. Yes <input type="checkbox"/> 5. No <input type="text" value="DK/RF"/>

W20CCKPT. CAI Checkpoint: Whether Dividend Account Reported But Dividend Income Was Not (Section G)

<input type="checkbox"/> 1. 1. Dividends Reported But Dividend Income Not Reported (W16=1-999,999,997) & (G25B[1]<>Yes & G25B[2]<>Yes)	<input type="checkbox"/> 5. All Others GO TO W21
↓	

W20E. *[RP + SP IN FU: For both [R=RP, SP: you and [[SP] / [RP]] / R=OFUM, PROXY: [RP] and [SP]], how much in dividends did [you / they] receive / ALL OTHERS: How much were [your / his / her] dividends] altogether in [PYEAR]?*

- Includes reinvested dividends
- ENTER amount here, then SELECT unit of time on next screen (Month, Year)

→ GO TO W21 → GO TO W20F



W20EPER. The amount entered is: [W20E] per ____

- SELECT the unit of time below

5. Month 6. Year 7. Other-specify (W20EPERSPEC. Specify. (String 100))

W20F. During which months of [PYEAR] did you get this income?

- ENTER all that apply
- PROBE: Any others?

<input type="checkbox"/> 1. January	<input type="checkbox"/> 2. February	<input type="checkbox"/> 3. March	<input type="checkbox"/> 4. April	<input type="checkbox"/> 5. May	<input type="checkbox"/> 6. June
<input type="checkbox"/> 7. July	<input type="checkbox"/> 8. August	<input type="checkbox"/> 9. September	<input type="checkbox"/> 10. October	<input type="checkbox"/> 11. November	<input type="checkbox"/> 12. December
<input type="checkbox"/> 13. All					

Annuities and Individual Retirement Account (IRA)

W21. (Do you [or anyone in your family living there] have...)

Any money in private annuities, or Individual Retirement Accounts (I.R.A.s)?

1. Yes 5. No → GO TO W27A



W21A. Are they mostly in stocks, mostly in interest earning assets, split between the two, or what?

1. Mostly stocks 2. Mostly interest earning 3. Split

W22. How much would they be worth?

\$ 1 – 999,999,997 → GO TO W27A

DK/RF



W23. Would it amount to \$50,000 or more?

1. Yes 5. No DK/RF → GO TO W27A

↓ ↓

W24. \$100,000 or more? W25. \$15,000 or more?

1. Yes 5. No DK/RF 1. Yes 5. No DK/RF

↓ ↓

GO TO W27A GO TO W27A

W26. \$250,000 or more?

1. Yes 5. No DK/RF

Checking, Savings, Money Market Accounts

W27A. Do you [or anyone in your family living there] have checking or savings accounts, including money market accounts?

1. Yes, one or more 5. No, none DK/RF



GO TO W27

W28A. If you added up all of your checking, saving, and money market accounts [for all of your family living there], about how much would they amount to altogether right now?

\$ -99,999,999 – 999,999,997 → GO TO W27

DK/RF



W29A. Would they amount to \$4,000 or more?

1. Yes 5. No DK/RF → GO TO W27

↓ ↓

W30A. \$15,000 or more? W32A. \$1,000 or more?

1. Yes 5. No DK/RF 1. Yes 5. No DK/RF

↓ ↓

GO TO W27 GO TO W27

W31A. \$60,000 or more?

1. Yes 5. No DK/RF

Certificate of Deposit (CD), Bonds, Treasury Bills

W27. Not including retirement accounts, do you [or anyone in your family living there] have any money in certificates of deposit, government bonds, or treasury bills?

1. Yes, one or more → GO TO W28 5. No, none DK/RF
 GO TO W31CCKPT

W28. If you added up all such accounts [for all of your family living there], about how much would they amount to altogether right now?

\$ 1 – 999,999,997 → GO TO W31CCKPT DK/RF

W29. Would they amount to \$5,000 or more?

1. Yes 5. No DK/RF → GO TO W31CCKPT

↓ ↓

W30. \$10,000 or more? W32. \$1,000 or more?

1. Yes 5. No DK/RF 1. Yes 5. No DK/RF

↓ GO TO W31CCKPT GO TO W31CCKPT

W31. \$50,000 or more?

1. Yes 5. No DK/RF

W31CCKPT. CAI Checkpoint: Whether Interest Account Reported But Interest Income Was Not (Section G)

1. Interest Reported But Interest Income Not Reported (W28A or W28=1-999,999,997) & (G25C[1]<>Yes & G25C[2]<>Yes) 5. All Others
 GO TO W33

↓

W31E. [RP + SP IN FU: For both [R=RP, SP: you and [[SP] / [RP]] / R=OFUM, PROXY: [RP] and [SP]], how much / ALL OTHERS: How much] interest did [you / they / he / she] earn altogether in [PYEAR]?

- ENTER amount here, then SELECT unit of time on next screen (Month, Year)

\$ 0 → GO TO W33 \$ 1 – 999,997 DK/RF → GO TO W31F

↓

W31EPER. The amount entered is: [W31E] per ____

- SELECT the unit of time below

5. Month 6. Year 7. Other-specify (W31EPERSPEC. Specify. (String 100))

W31F. During which months of [PYEAR] did you get this income?

- ENTER all that apply
- PROBE: Any others?

1. January 2. February 3. March 4. April 5. May 6. June
 7. July 8. August 9. September 10. October 11. November 12. December 13. All

Life Insurance, Collections, Trusts, Estates

W33. (Do you [or anyone in your family living there] have...)

Any other savings or assets, such as cash value in a life insurance policy, a valuable collection for investment purposes, or rights in a trust or estate that you haven't already told us about?

1. Yes 5. No → GO TO W38A



W34. If you sold that and paid off any debts on it, how much would you have?

→ GO TO W38A DK/RF



W35. Would it amount to \$10,000 or more?	
<input type="checkbox"/> 1. Yes	<input type="checkbox"/> 5. No <input type="checkbox"/> DK/RF → GO TO W38A
↓	↓
W36. \$25,000 or more?	W37. \$2,000 or more?
<input type="checkbox"/> 1. Yes <input type="checkbox"/> 5. No <input type="checkbox"/> DK/RF	<input type="checkbox"/> 1. Yes <input type="checkbox"/> 5. No <input type="checkbox"/> DK/RF

Credit Card Debt

W38A. Aside from the debts that we have already talked about, [*A23=YES MTGE*: like any mortgage on your main home [*F65/F67=YES VEH LOAN>0*: [or / like] vehicle loans,]] do you [or anyone in your family living there] currently have any credit card or store card debt? Do not count new debt that will be paid off this month.

1. Yes 5. No → GO TO W38B



W39A. If you added up all credit card and store card debts [for all of your family living there], about how much would they amount to right now? (Please do not count any new debt that will be paid off this month.)

- **INCLUDE unpaid balance(s) only, or credit card and store card debts that are outstanding**

→ GO TO W38B DK/RF



W40A. Would they amount to \$5,000 or more?	
<input type="checkbox"/> 1. Yes	<input type="checkbox"/> 5. No <input type="checkbox"/> DK/RF → GO TO W38B
↓	↓
W41A. (Would they amount to) \$10,000 or more?	W42A. (Would they amount to) \$1,000 or more?
<input type="checkbox"/> 1. Yes <input type="checkbox"/> 5. No <input type="checkbox"/> DK/RF	<input type="checkbox"/> 1. Yes <input type="checkbox"/> 5. No <input type="checkbox"/> DK/RF
↓	↓
GO TO W38B	GO TO W38B
W43A. (Would they amount to) \$15,000 or more?	
<input type="checkbox"/> 1. Yes <input type="checkbox"/> 5. No <input type="checkbox"/> DK/RF	

Debt from Student Loans, Medical and Legal Bills, Loans from Relatives

W38B. Do you [or anyone in your family living there] currently have any other debts such as student loans, medical or legal bills, or loans from relatives?

- ENTER all that apply
- PROBE: Any others?

1. Student loans	2. Medical bills	3. Legal bills	4. Loans from relatives	7. Other-specify	5. No	DK/RF
------------------	------------------	----------------	-------------------------	------------------	-------	-------

↓

GO TO W43

W38B=Student loans

W39B1. If you added up all student loans [for all of your family living there], about how much would they amount to right now?

- INCLUDE unpaid balance(s), or student loans that are outstanding

\$ 1 – 9,999,997	→ GO TO NEXT W38B ITEM / W43	DK/RF
------------------	------------------------------	-------

↓

W40B1. Would they amount to \$25,000 or more?		
1. Yes	5. No	DK/RF → GO TO NEXT W38B ITEM / W43
↓	↓	
W41B1. (Would they amount to \$50,000 or more?)	W42B1. (Would they amount to \$10,000 or more?)	
1. Yes 5. No DK/RF	1. Yes 5. No DK/RF	
↓	↓	
GO TO NEXT W38B ITEM / W43	GO TO NEXT W38B ITEM / W43	
W43B1. (Would they amount to \$75,000 or more?)		
1. Yes	5. No	DK/RF
GO TO NEXT W38B ITEM / W43		

W38B= Medical bills

W39B2. [W38B=STUDENT LOANS: How about medical bills (how much would they amount to right now) / ALL OTHERS: If you added up all medical bills [for all of your family living there], about how much would they amount to right now?]

- INCLUDE unpaid balance(s), or medical bills that are outstanding

\$ 1 – 9,999,997	→ GO TO NEXT ITEM / W43	DK/RF
------------------	-------------------------	-------

↓

W40B2. Would they amount to \$3,000 or more?		
1. Yes	5. No	DK/RF → GO TO NEXT W38B ITEM / W43
↓	↓	
W41B2. (Would they amount to \$10,000 or more?)	W42B2. (Would they amount to \$1,000 or more?)	
1. Yes 5. No DK/RF	1. Yes 5. No DK/RF	
↓	↓	
GO TO NEXT W38B ITEM / W43	GO TO NEXT W38B ITEM / W43	
W43B2. (Would they amount to \$25,000 or more?)		
1. Yes	5. No	DK/RF
GO TO NEXT W38B ITEM / W43		

W38B= Legal bills

W39B3. [W38B=STUDENT LOANS, MEDICAL BILLS: How about legal bills (how much would they amount to right now) / ALL OTHERS: If you added up all legal bills [for all of your family living there], about how much would they amount to right now?]

- INCLUDE unpaid balance(s), or legal bills that are outstanding

\$ 1 – 9,999,997	→ GO TO NEXT W38B ITEM / W43	DK/RF
↓		
W40B3. Would they amount to \$3,000 or more?		
1. Yes	5. No	DK/RF → GO TO NEXT W38B ITEM / W43
↓		
W41B3. (Would they amount to)	W42B3. (Would they amount to)	
\$8,000 or more?	\$1,000 or more?	
1. Yes	5. No	DK/RF
↓		
GO TO NEXT W38B ITEM / W43		GO TO NEXT W38B ITEM / W43
W43B3. (Would they amount to)		
\$20,000 or more?		
1. Yes	5. No	DK/RF
GO TO NEXT W38B ITEM / W43		

W38B= Loans from relatives

W39B4. [W38B=STUDENT LOANS, MEDICAL BILLS, LEGAL BILLS: How about loans from relatives (how much would they amount to right now) / ALL OTHERS: If you added up all loans from relatives [for all of your family living there], about how much would they amount to right now?]

- INCLUDE unpaid balance(s), or loans from relatives that are outstanding

\$ 1 – 9,999,997	→ GO TO NEXT W38B ITEM / W43	DK/RF
↓		
W40B4. Would they amount to \$4,000 or more?		
1. Yes	5. No	DK/RF → GO TO NEXT W38B ITEM / W43
↓		
W41B4. (Would they amount to)	W42B4. (Would they amount to)	
\$10,000 or more?	\$1,000 or more?	
1. Yes	5. No	DK/RF
↓		
GO TO NEXT W38B ITEM / W43		GO TO NEXT W38B ITEM / W43
W43B4. (Would they amount to)		
\$20,000 or more?		
1. Yes	5. No	DK/RF
GO TO NEXT W38B ITEM / W43		

W38B=Other

W39B7A. What were those other debts?

- Specify

String 200

W39B7. If you added up all other debts [for all of your family living there], about how much would they amount to right now?

- INCLUDE unpaid balance(s), or other debts that are outstanding

→ GO TO NEXT W38B ITEM / W43

W40B7. Would they amount to \$4,000 or more?	
<input type="text" value="1. Yes"/>	<input type="text" value="5. No"/> <input type="text" value="DK/RF"/> → GO TO NEXT W38B ITEM / W43
↓	↓
W41B7. (Would they amount to) \$10,000 or more?	W42B7. (Would they amount to) \$1,000 or more?
<input type="text" value="1. Yes"/> <input type="text" value="5. No"/> <input type="text" value="DK/RF"/>	<input type="text" value="1. Yes"/> <input type="text" value="5. No"/> <input type="text" value="DK/RF"/>
↓	↓
GO TO NEXT W38B ITEM / W43	GO TO NEXT W38B ITEM / W43
W43B7. (Would they amount to) \$20,000 or more?	
<input type="text" value="1. Yes"/> <input type="text" value="5. No"/> <input type="text" value="DK/RF"/>	
GO TO NEXT W38B ITEM / OR W43	

Money into or Cash from Annuity or IRA

W43. These next questions are about changes in your wealth during the last two years. [R=RP, SP, OFUM: In these questions, when I refer to you I mean you and any family members living with you during that time.] Since January [P2YEAR], did you [or anyone in your family living there] put aside money in any private annuities or I.R.A.s (Individual Retirement Account)?

→ GO TO W48

↓

W44. How much did that amount to?

→ GO TO W48

↓

W45. Was it \$10,000 or more?	
<input type="text" value="1. Yes"/>	<input type="text" value="5. No"/> <input type="text" value="DK/RF"/> → GO TO W48
↓	↓
W46. \$50,000 or more?	W47. \$5,000 or more?
<input type="text" value="1. Yes"/> <input type="text" value="5. No"/> <input type="text" value="DK/RF"/>	<input type="text" value="1. Yes"/> <input type="text" value="5. No"/> <input type="text" value="DK/RF"/>

W48. (Since January [P2YEAR], did you [or anyone in your family living there]...)

Cash in any part of a pension, private annuity or I.R.A. (Individual Retirement Account)?

1. Yes 5. No → GO TO W54



W49. How much did that amount to?

\$ 1 – 999,999,997 → GO TO W54

DK/RF



W50. Was it \$10,000 or more?

1. Yes

5. No DK/RF → GO TO W54



W51. \$50,000 or more?

W53. \$5,000 or more?

1. Yes 5. No DK/RF

1. Yes 5. No DK/RF



GO TO W54

GO TO W54

W52. \$100,000 or more?

1. Yes 5. No DK/RF

Buy or Sell Real Estate

W54. (Since January [P2YEAR], did you [or anyone in your family living there]...)

Sell any home you were using as your main residence?

1. Yes 5. No → GO TO W59A



W55. About how much was the selling price, not including selling commissions and costs?

- IF R sold more than one main home, ask about the one owned in January, [P2YEAR]

\$ 1 – 999,999,997 → GO TO W59A

DK/RF



W56. Was it \$60,000 or more?

1. Yes

5. No DK/RF → GO TO W59A



W57. \$120,000 or more?

W58. \$30,000 or more?

1. Yes 5. No DK/RF

1. Yes 5. No DK/RF

W59A. (Since January [P2YEAR], did you [or anyone in your family living there]...)

Buy or sell any real estate other than your main home, such as a vacation home, land (not including farmland), or rental property?

- If R says only “Yes”, PROBE: Did you buy only, sell only, or both?
- If needed: Real estate [A19=OWNS: other than [your main home,] such as a vacation home, land (not including farmland), or rental property

1. Yes, bought only 2. Yes, sold only 3. Yes, both bought and sold 5. No, neither DK/RF



GO TO W65CKPT



GO TO W65CKPT

W60. Altogether, how much money did you [or anyone in your family living there] spend on (real estate) (since January [P2YEAR])?

- **If needed:** Real estate [A19=OWNS: other than [your main home,] such as a vacation home, land (not including farmland), or rental property

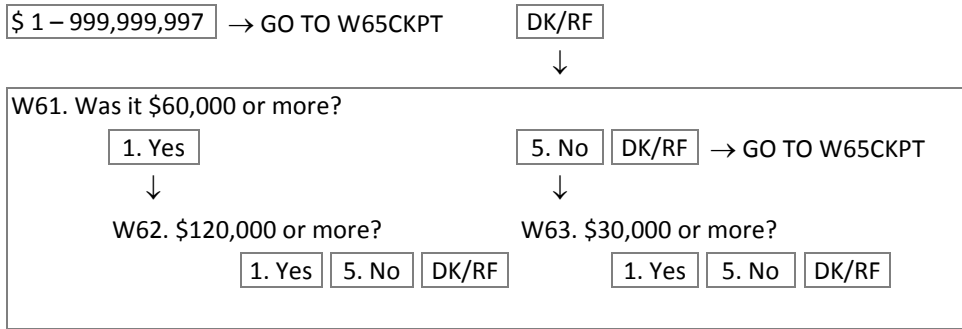

W65CKPT. CAI Checkpoint: Whether Sold Only or Both Bought & Sold Real Estate

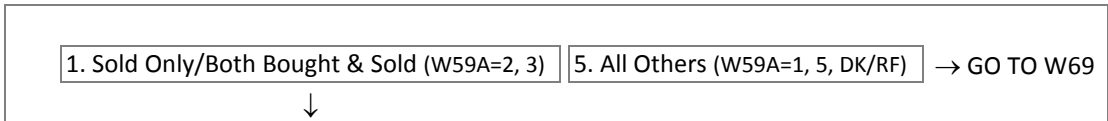

W65. Altogether, how much money you [or anyone in your family living there] get from selling real estate (since January [P2YEAR])?

- **If needed:** Real estate [A19=OWNS: other than [your main home,] such as a vacation home, land (not including farmland), or rental property

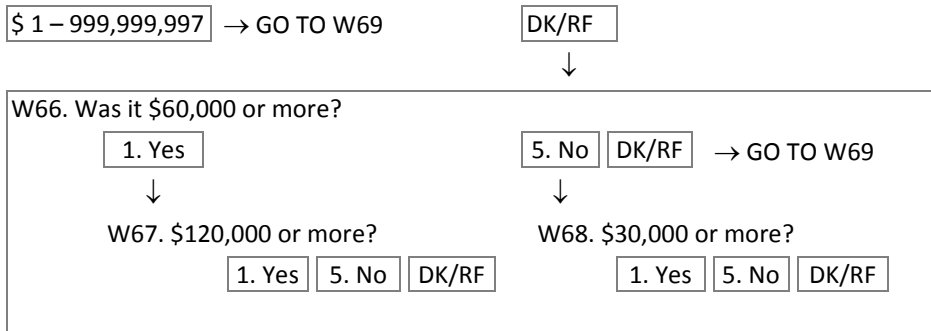

Home Improvements

W69. (Since January [P2YEAR], did you [or anyone in your family living there] ...)

Make additions or improvements totaling \$10,000 or more to any homes or other real estate [you / any of you] owned? Do not count general maintenance or upkeep.

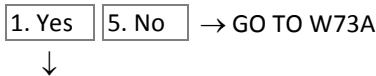

W70. What was the total dollar cost of the additions or improvements, plus the value of any work you may have done yourself?

→ GO TO W73A



W71. Was it \$25,000 or more?

 ↓ GO TO W73A

W72. \$75,000 or more?

Buy or Sell Business or Farm

W73A. (Since January [P2YEAR], did you [or anyone in your family living there] ...) Put money into or sell part or all of your interest in a business or farm?

- If R says only "Yes", PROBE: Did you put money in only, sell only, or both?



GO TO W79CKPT



GO TO W79CKPT

W74. Altogether, how much money did you [or anyone in your family living there] put into a business or farm (since January [P2YEAR])?

→ GO TO W79CKPT



W75. Was it \$25,000 or more?
 → GO TO W79CKPT
 ↓ ↓

W76. \$100,000 or more? W77. \$10,000 or more?

W79CKPT. CAI Checkpoint: Whether Sold Only or Both Put Money in & Sold Farm/Business

→ GO TO W83A
 ↓

W79. Altogether, how much money did you [or anyone in your family living there] get from selling a business or farm (since January [P2YEAR])?

→ GO TO W83A



W80. Was it \$25,000 or more?



W81. \$100,000 or more?

→ GO TO W83A



W82. \$10,000 or more?

Buy or Sell Stock

W83A. (Since January [P2YEAR], did you [or anyone in your family living there] ...)

Buy or sell any shares of stock in publicly held corporations, stock mutual funds, or investment trusts, including any automatic reinvestments - not including any retirement accounts?

- If R says "Yes", PROBE: Did you buy only, sell only, or both?



GO TO W97CKPT



GO TO W97CKPT

W91. Altogether, how much money did you [or anyone in your family living there] spend on (shares of) stocks (since January [P2YEAR])?

→ GO TO W97CKPT



W92. Was it \$20,000 or more?



W93. \$50,000 or more?



GO TO W97CKPT

W94. \$100,000 or more?

→ GO TO W97CKPT



W95. \$5,000 or more?

GO TO W97CKPT

W97CKPT. CAI Checkpoint: Whether Sold Only or Both Bought & Sold Stock

→ GO TO W102CKPT



W97. Altogether, how much money did you [or anyone in your family living there] get from selling (shares of) stocks (since January [P2YEAR])?

→ GO TO W102CKPT



W98. Was it \$20,000 or more?	
<input type="text" value="1. Yes"/>	<input type="text" value="5. No"/> <input type="text" value="DK/RF"/> → GO TO W102CKPT
↓	↓
W99. \$50,000 or more?	W101. \$5,000 or more?
<input type="text" value="1. Yes"/> <input type="text" value="5. No"/> <input type="text" value="DK/RF"/>	<input type="text" value="1. Yes"/> <input type="text" value="5. No"/> <input type="text" value="DK/RF"/>
↓	↓
GO TO W102CKPT	GO TO W102CKPT
W100. \$100,000 or more?	
<input type="text" value="1. Yes"/> <input type="text" value="5. No"/> <input type="text" value="DK/RF"/>	

Assets or Debts from Movers-In or Movers-Out

W102CKPT. CAI Checkpoint: Whether There are Movers-Out Age 18+ Years Old (Family Listing)

<input type="text" value="1. Movers-Out Age 18+"/>	<input type="text" value="5. All Others"/>	→ GO TO W112CKPT
↓		

W102. Sometimes changes in a family's savings or assets are due to people joining or leaving the family. Was there anyone living with you in January [P2YEAR] who doesn't live with you now and who took \$5,000 or more in assets or debts away with them?

→ GO TO W112CKPT



W103. Altogether, what is the total dollar value of assets that were removed that way?

→ GO TO W108



W104. Was it \$10,000 or more?	
<input type="text" value="1. Yes"/>	<input type="text" value="5. No"/> <input type="text" value="DK/RF"/> → GO TO W108
↓	↓
W105. \$25,000 or more?	W107. \$5,000 or more?
<input type="text" value="1. Yes"/> <input type="text" value="5. No"/> <input type="text" value="DK/RF"/>	<input type="text" value="1. Yes"/> <input type="text" value="5. No"/> <input type="text" value="DK/RF"/>
↓	↓
GO TO W108	GO TO W108
W106. \$100,000 or more?	
<input type="text" value="1. Yes"/> <input type="text" value="5. No"/> <input type="text" value="DK/RF"/>	

W108. Altogether, what is the total dollar value of debts that were removed that way?

→ GO TO W112CKPT



W109. Was it \$10,000 or more?		
<input type="text" value="1. Yes"/>	<input type="text" value="5. No"/>	<input type="text" value="DK/RF"/> → GO TO W112CKPT
↓	↓	
W110. \$25,000 or more?	W111. \$5,000 or more?	
<input type="text" value="1. Yes"/> <input type="text" value="5. No"/> <input type="text" value="DK/RF"/>	<input type="text" value="1. Yes"/> <input type="text" value="5. No"/> <input type="text" value="DK/RF"/>	

SIGNAL for W103 + W108 < \$5,000: Reported assets and debts removed total less than \$5,000. Please verify amounts at W103 and W108.

W112CKPT. CAI Checkpoint: Whether There are Movers-In Age 18+ Years Old (Family Listing)

<input type="text" value="1. Movers-In Age 18+"/>	<input type="text" value="5. All Others"/>	→ GO TO W123
↓		

W113. Is there anyone in your family living with you now who has joined the family since January [P2YEAR] and who had \$5,000 or more in assets or debts at the time they joined the family?

→ GO TO W123



W114. Altogether, what is the total dollar value of assets that were brought into the family that way?

→ GO TO W119



W115. Was it \$10,000 or more?		
<input type="text" value="1. Yes"/>	<input type="text" value="5. No"/>	<input type="text" value="DK/RF"/> → GO TO W119
↓	↓	
W116. \$25,000 or more?	W118. \$5,000 or more?	
<input type="text" value="1. Yes"/> <input type="text" value="5. No"/> <input type="text" value="DK/RF"/>	<input type="text" value="1. Yes"/> <input type="text" value="5. No"/> <input type="text" value="DK/RF"/>	
↓	↓	
GO TO W119		GO TO W119
W117. \$100,000 or more?		
<input type="text" value="1. Yes"/> <input type="text" value="5. No"/> <input type="text" value="DK/RF"/>		

W119. Altogether, what is the total dollar value of debts that were brought into the family that way?

→ GO TO W123



W120. Was it \$10,000 or more?	
<input type="text" value="1. Yes"/>	<input type="text" value="5. No"/> <input type="text" value="DK/RF"/> → GO TO W123
↓	↓
W121. \$25,000 or more?	W122. \$5,000 or more?
<input type="text" value="1. Yes"/> <input type="text" value="5. No"/> <input type="text" value="DK/RF"/>	<input type="text" value="1. Yes"/> <input type="text" value="5. No"/> <input type="text" value="DK/RF"/>

SIGNAL for W114 + W119 < \$5,000: Reported assets and debts brought total less than \$5,000. Please verify amounts at W114 and W119.

Large Gifts and Inheritances

W123. Some people's assets come from gifts and inheritances. During the last two years, have you [or anyone in your family living there] received any large gifts or inheritances of money or property worth \$10,000 or more?

→ GO TO SECT P



SECTION_W.W123A_W128[1-3] [1-3]=Which inheritance/gift

W123A. Was that a gift or was that an inheritance? If multiple gifts or inheritances worth \$10,000 or more were received, we can talk about each one separately.

W124A. What year did you [or anyone in your family living there] receive that? (If multiple gifts or inheritances worth \$10,000 or more were received, we can talk about each one separately.)

- **ENTER all that apply**
- **PROBE:** Any others?
- **ENTER [7] if it has not yet been received**



GO TO W128

W125. How much was [W123A=1: that gift / W123A=2: that inheritance / ALL OTHERS: it] worth altogether, at the time it was received? (If multiple gifts or inheritances worth \$10,000 or more were received, we can talk about each one separately.)

→ GO TO W128



W126. Would it amount to \$25,000 or more?	
<input type="text" value="1. Yes"/>	<input type="text" value="5. No"/> <input type="text" value="DK/RF"/>
↓	GO TO W128
W127. \$75,000 or more?	
<input type="text" value="1. Yes"/>	<input type="text" value="5. No"/> <input type="text" value="DK/RF"/>

W128. Did you [or anyone in your family living there] receive any other large gifts or inheritances of money or property worth \$10,000 or more in the last two years?

1. Yes → Repeat W123A_W128; Max=3; 5. No → GO TO SECTION P
Then GO TO SECTION P

END W123A_W128

END SECTION_W

Section P: Pensions

[TOC](#)

SECTION_P

P0CKPT1. CAI Checkpoint: Employment Status of Reference Person

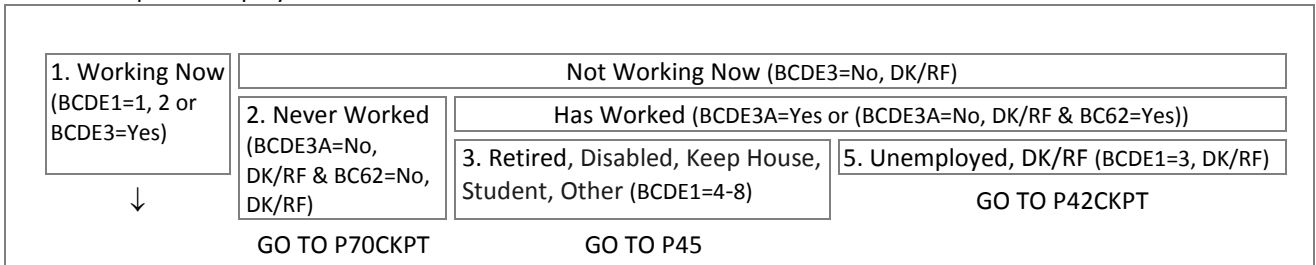

Pension from Current Employer – Reference Person and Spouse/Partner

SECTION_P.SECTION_PDETAIL [1-2] [1]=Current Reference Person, [2]=Current Spouse/Partner

PDETAILAQS. AQS. of Current Reference Person (Spouse/Partner)

P1. [CYAQRTH, CYNAMF CYNAML], Current Employer: [EMPNAME] ([BEG] – [END])

[1st ITERATION: Next, I need to get some information about pensions and retirement plans.] Not including Social Security, Railroad Retirement, or I.R.A.s (Individual Retirement Accounts), [are you / is [RP / SP]] participating in a pension or retirement plan through [your / his / her] present job [EMPLOYER NAME=RESPONSE: at [CMJ EMPLOYER]] [BC27=YES:, or through [your / his / her] union]?

- If R says “participating but hasn’t recently contributed”, ENTER [1]
- If R says “eligible but not participating”, ENTER [5]
- If R says there are multiple plans, ENTER [1]

1. Yes → GO TO P6CKPT 5. No DK/RF → GO TO P42CKPT



No Plan With Current Employer

P1A. [CYAQRTH, CYNAMF CYNAML], Current Employer: [EMPNAME] ([BEG] – [END])

[Are you / Is [he / she]] currently eligible for such a plan?

1. Yes → GO TO P42CKPT 5. No DK/RF → GO TO P42CKPT



P7. [CYAQRTH, CYNAMF CYNAML], Current Employer: [EMPNAME] ([BEG] – [END])

Will [you / he / she] become eligible for such a plan if [you / he / she] continue[s] to work for this employer?

1. Yes 5. No

GO TO P42CKPT

P6CKPT. CAI Checkpoint: Whether Same CMJ as Last Wave (Section BC SAMECMJ)

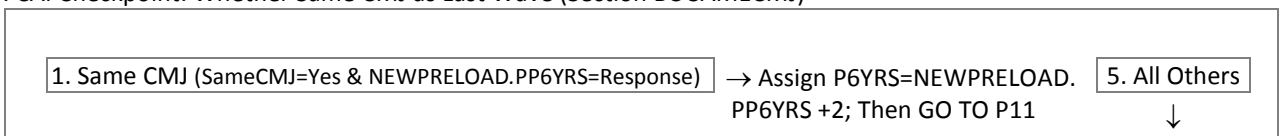

*Dependent Interviewing for Reinterviews*Plan with Current Employer

P6YRS. [CYAQRTH, CYNAMF CYNAML], Plan Through Current Employer ([EMPNAME] ([BEG] – [END]))

How many years [have you / has [he / she]] been participating in this plan?

- ENTER [0] for “Less than one year”
- If R says there are multiple plans, PROBE: Please tell me about the plan [you have / [he / she] has] participated in the longest.
- ENTER number of years in pension or retirement plan or PRESS [ENTER] to go to the next screen to record the year started

[ENTER] 0 – 50 DK/RF
↓ GO TO P11

P6YR. [CYAQRTH, CYNAMF CYNAML], Plan Through Current Employer ([EMPNAME] ([BEG] – [END]))

(In which year did [you / he / she] start participating in this plan?)

- If R says there are multiple plans, PROBE: Please tell me about the plan [you have / [he / she] has] participated in the longest.
- ENTER year started in pension or retirement plan

1901 – [CYEAR]

Plan with Current Employer

P11. [CYAQRTH, CYNAMF CYNAML], Plan Through Current Employer ([EMPNAME] ([BEG] – [END]))

[Are you / Is [he / she]] making any contributions to [your / his / her] pension or retirement account such as having money deducted from your [your / his / her] pay?

1. Yes 5. No → GO TO P16

↓

P12. [CYAQRTH, CYNAMF CYNAML], Plan Through Current Employer ([EMPNAME] ([BEG] – [END]))

[Are you / Is [he / she]] required to contribute?

1. Yes 5. No → GO TO P15AMT

↓

P13AMT. [CYAQRTH, CYNAMF CYNAML], Plan Through Current Employer ([EMPNAME] ([BEG] – [END]))

What amount or percent of pay [are you / is [he / she]] required to contribute?

- ENTER dollar amount here, then SELECT unit of time on next screen (Week, Two weeks, Month, Year)
- OR press [ENTER] to continue to next screen for Percent

[ENTER] → GO TO P13PCT \$ 1 – 9,999,997 DK/RF → GO TO P14

↓

P13PER. The amount entered is: [P13AMT] per ____

- SELECT the unit of time below

3. Week 4. Two weeks 5. Month 6. Year

7. Other-specify (P13PERSPEC. Specify. (String 100))

GO TO P14

P13PCT. [CYAQRTH, CYNAMF CYNAML], Plan Through Current Employer ([EMPNAME] ([BEG] – [END]))

(What percent of pay [are you / is [he / she]] required to contribute?)

- ENTER a percentage from 1.0 to 25.0

1.0 – 25.0

Plan with Current Employer

P14. [CYAQRTH, CYNAMF CYNAML], Plan Through Current Employer ([EMPNAME] ([BEG] – [END]))

[Do you / Does [he / she]] also make voluntary contributions?

→ GO TO P16



P15AMT. [CYAQRTH, CYNAMF CYNAML], Plan Through Current Employer ([EMPNAME] ([BEG] – [END]))

What amount or percent of pay [do you / does [he / she]] voluntarily contribute currently?

- ENTER dollar amount here, then SELECT unit of time on next screen (Week, Two weeks, Month, Year)
- OR press [ENTER] to continue to next screen for Percent

→ GO TO P15PCT → GO TO P16



P15PER. The amount entered is: [P15AMT] per ____

- SELECT the unit of time below

GO TO P16

P15PCT. [CYAQRTH, CYNAMF CYNAML], Plan Through Current Employer ([EMPNAME] ([BEG] – [END]))

(What percent of pay [do you / does [he / she]] voluntarily contribute currently?)

- ENTER a percentage from 1.0 to 50.0

Plan with Current Employer

P16. [CYAQRTH, CYNAMF CYNAML], Plan Through Current Employer ([EMPNAME] ([BEG] – [END]))

[SP LOOP & RP HAS PENSION W/CURRENT EMPLOYER: ()] Some pension and retirement plans base benefits on a formula involving age, years of service and salary. Other plans, such as a 401K, base benefits on how much money has accumulated in a person's pension or retirement account. And some plans use both ways of setting benefits.

[SP LOOP & RP HAS PENSION W/CURRENT EMPLOYER:)]

What type of plan [do you / does [RP / SP]] have (through [EMPNAME])?

- Defined Contribution plans include 401-K, 403-B, ESOP, SRA, thrift/savings, stock/profit sharing, money purchase plans, and target date funds (TDF)

→ GO TO P22CKPT

GO TO P22CKPT

Plan with Current Employer - Defined Contribution (P16=DC Only or Both)

P17. [CYAQRTH, CYNAMF CYNAML], Plan Through Current Employer ([EMPNAME] ([BEG] – [END]))

Does [your / his / her] employer make contributions to [your / his / her] account?

→ GO TO P20



P18AMT. [CYAQRTH, CYNAMF CYNAML], Plan Through Current Employer ([EMPNAME] ([BEG] – [END]))
 What amount or percent of pay does [your / his / her] employer contribute to [your / his / her] account?

- ENTER dollar amount here, then SELECT unit of time on next screen (Week, Two weeks, Month, Year)
- OR press [ENTER] to continue to next screen for Percent of pay or Percent of employee contribution

[ENTER] → GO TO P18PCT \$ 1 – 9,999,997 DK/RF → GO TO P20



P18PER. The amount entered is: [P18AMT] per ____

- SELECT the unit of time below

3. Week 4. Two weeks 5. Month 6. Year
 7. Other-specify (P18PERSPEC. Specify. (String 100))

GO TO P20

P18PCT. [CYAQRTH, CYNAMF CYNAML], Plan Through Current Employer ([EMPNAME] ([BEG] – [END]))
 (What percent of pay does [your / his / her] employer contribute to [your / his / her] account?)

- ENTER a percentage of pay from 1.0 to 25.0
- OR press [ENTER] to continue to next screen for Percent of employee contribution

[ENTER] 1.0 – 25.0 DK/RF



GO TO P20

P18PCTB. [CYAQRTH, CYNAMF CYNAML], Plan Through Current Employer ([EMPNAME] ([BEG] – [END]))
 (What percent of [your / his / her] contribution does [your / his / her] employer contribute to [your / his / her] account?)

- ENTER a percentage of employee contribution from 1.0 to 200.0

1.0 – 200.0

P20. [CYAQRTH, CYNAMF CYNAML], Plan Through Current Employer ([EMPNAME] ([BEG] – [END]))

What is the approximate dollar amount in [your / his / her] account now?

\$ 1 – 999,999,997 → GO TO P20A DK/RF

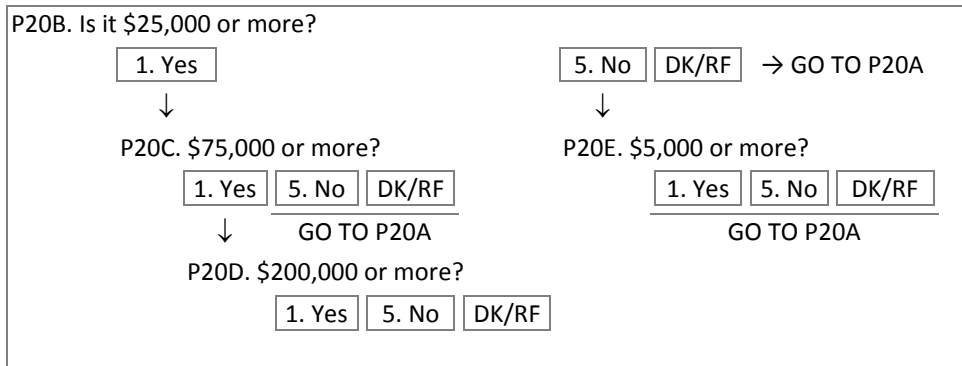

P20A. [CYAQRTH, CYNAMF CYNAML], Plan Through Current Employer ([EMPNAME] ([BEG] – [END]))

Are the funds invested mostly in stocks and stock mutual funds, mostly in bonds, bond mutual funds and annuities, or some of each?

1. Mostly (or all) stocks 2. Some of each 3. Mostly (or all) bonds and annuities

P22CKPT. CAI Checkpoint: Type of Pension; Whether 40 Years Old or Older

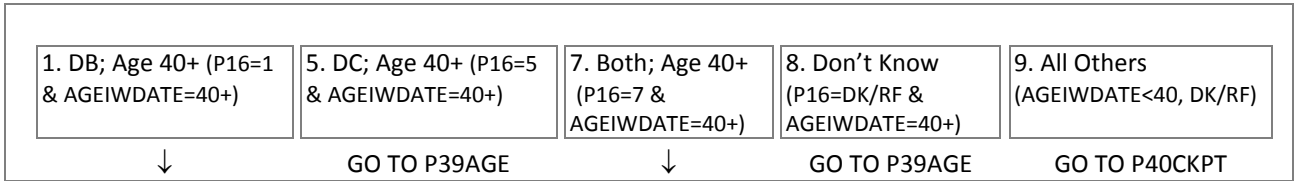

Plan with Current Employer - Defined Benefit - Age 40+ (P16=DB Only or Both)

P32. [CYAQRTH, CYNAMF CYNAML], Plan Through Current Employer ([EMPNAME] ([BEG] – [END]))

[P16=BOTH: (For the part of [your / his/ her] pension or retirement plan where benefits are based on a formula,) at / ALL OTHERS: At] what age [do you / does [he / she]] expect to start receiving retirement benefits from this pension or retirement plan?

- ENTER [997] for Never; won't stay long enough

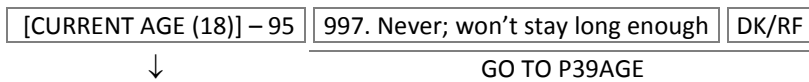

P34AMT. [CYAQRTH, CYNAMF CYNAML], Plan Through Current Employer ([EMPNAME] ([BEG] – [END]))

[P16=BOTH: (For the part of [your / his/ her] pension or retirement plan where benefits are based on a formula,) how / ALL OTHERS: How] much [do you / does [he / she]] expect to receive (either as a percent of [your / his / her] pay at retirement or as an amount per month or year)?

- ENTER dollar amount here, then SELECT unit of time on next screen (Month, Year)
- OR press [ENTER] to continue to next screen for Percent

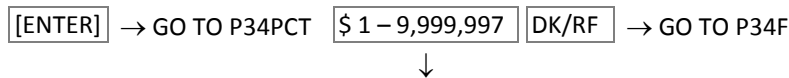

P34PER. The amount entered is: [P34AMT] per ____

- SELECT the unit of time below

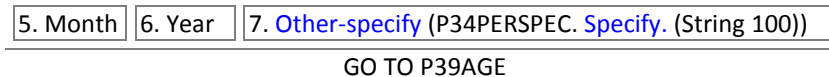

P34PCT. [CYAQRTH, CYNAMF CYNAML], Plan Through Current Employer ([EMPNAME] ([BEG] – [END]))

[(P16=BOTH: (For the part of [your / his/ her] pension or retirement plan where benefits are based on a formula,) how / ALL OTHERS: How] much [do you / does [he / she]] expect to receive (as a percent of [your / his / her] pay at retirement)?

- ENTER a percentage from 1.0 to 100.0

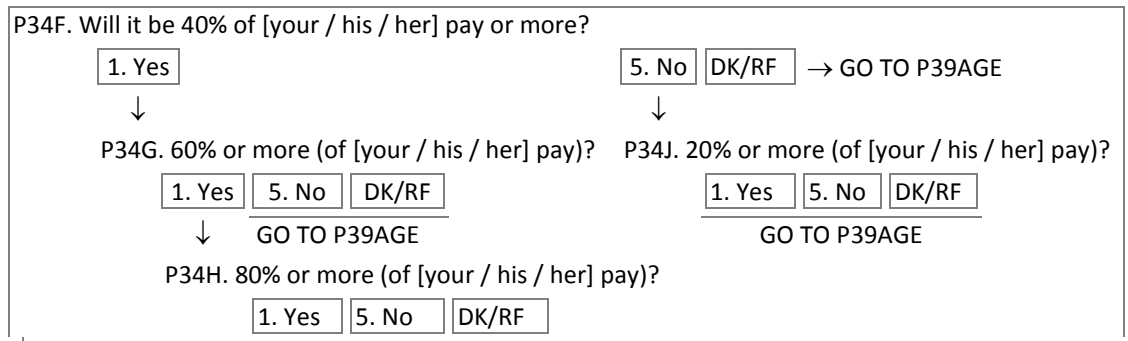
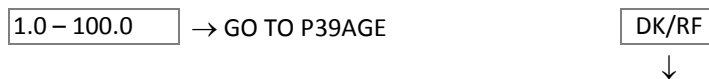

Plan with Current Employer - Age 40+

P39AGE. [CYAQRTH, CYNAMF CYNAML], Plan Through Current Employer ([EMPNAME] ([BEG] – [END]))

On [your / his / her] present job [EMPLOYER NAME IS RESPONSE: at [CMJ EMPLOYER]], what is the usual retirement age (or years of service) for people who work with [you / him / her] or have the same kind of job?

- ENTER usual age of retirement or press [ENTER] to continue to next screen for years of service

[ENTER] [20 – 75] → GO TO P40CKPT [DK/RF]

↓

↓

P39YRS. [CYAQRTH, CYNAMF CYNAML], Plan Through Current Employer ([EMPNAME] ([BEG] – [END]))

(What is the usual number of years of service for retirement?)

- ENTER number of years

[1 – 50]

P40CKPT. CAI Checkpoint: Whether 40 Years Old or Older

[1. Age 40+ (AGEIWDATE>=40)] [5. All Others (AGEIWDATE<40, DK/RF)] → GO TO P42CKPT

↓

Plan with Current Employer - Age 40+

P40AGE. [CYAQRTH, CYNAMF CYNAML], Plan Through Current Employer ([EMPNAME] ([BEG] – [END]))

Now I want to ask about [your / [RP / SP]'s] plans for retirement. At what age [do you / does [he / she]] plan to stop working?

- ENTER age or press [ENTER] to continue to next screen for number of years
- ENTER [996] for Already stopped working
- ENTER [997] for Never

[ENTER] [CURRENT AGE] – 95 [996. Already stopped working] [997. Never] [DK/RF]

↓

GO TO P42CKPT

P40NUM. [CYAQRTH, CYNAMF CYNAML], Plan Through Current Employer ([EMPNAME] ([BEG] – [END]))

(In how many years [do you / does [he / she]] plan to stop working?)

- ENTER number of years

[1 – 50]

P42CKPT. CAI Checkpoint: Employment Status (Section BC)

[1. Working Now (BCDE1=1, 2 Or BCDE3=Yes)] [5. All Others] → GO TO P45

↓

Other Tax-Deferred Plans - Reference Person and Spouse/Partner

P42. [CYAQRTH, CYNAMF CYNAML], Other Plan(s) Through Current Employer ([EMPNAME] ([BEG] – [END]))

[P1=YES: In addition to the pension or retirement plan you already mentioned, [do you / does [RP / SP]] / ALL OTHERS: [Do you / Does [RP / SP]]] have any tax-deferred compensation or savings plans on [your / his / her] present job, such as a “thrift”, profit-sharing, or Keogh plan?

[1. Yes] [5. No] → GO TO P45

↓

P43. [CYAQRTH, CYNAMF CYNAML], Other Plan(s) Through Current Employer ([EMPNAME] ([BEG] – [END]))

Does [your / his / her] employer make contributions to any such plan for [you / him / her]?

→ GO TO P45



P44AMT. [CYAQRTH, CYNAMF CYNAML], Other Plan(s) Through Current Employer ([EMPNAME] ([BEG] – [END]))

What amount or percent of pay does [your / his / her] employer contribute?

- ENTER dollar amount here, then SELECT unit of time on next screen (Week, Two weeks, Month, Year)
- OR press [ENTER] to continue to next screen for Percent of pay or Percent of employee contribution

→ GO TO P44PCT → GO TO P45



P44PER. The amount entered is: [P44AMT] per ____

- SELECT the unit of time below

GO TO P45

P44PCT. [CYAQRTH, CYNAMF CYNAML], Other Plan(s) Through Current Employer ([EMPNAME] ([BEG] – [END]))

(What percent of pay does [your / his / her] employer contribute?)

- ENTER a percentage of pay from 1.0 to 25.0
- OR press [ENTER] to continue to next screen for Percent of employee contribution



GO TO P45

P44PCTB. [CYAQRTH, CYNAMF CYNAML], Other Plan(s) Through Current Employer ([EMPNAME] ([BEG] – [END]))

(What percent of [your / his / her] contribution does [your / his / her] employer contribute?)

- ENTER a percentage of employee contribution from 1.0 to 200.0

Pensions from Former Employers - Reference Person and Spouse/Partner

SECTION_P.SECTION_PDETAIL [1-2].P45_P69 [1-2] [1]=Current Reference Person, [2]=Current Spouse/Partner; [1-2]=Plan

P45. [CYAQRTH, CYNAMF CYNAML]

[LOOP 2 & SP NOT WORKING NOW: (These next questions are about [your / [SP]'s] pensions or retirement plans through a former employer.)] / ALL OTHERS: These next questions are about [your / [RP / SP]'s] pensions or retirement plans through a former employer.]

Aside from I.R.A. (Individual Retirement Account) or Keogh Plans already reported, [do you / does [RP / SP]] have any pensions or retirement plans from previous employers from which [you / he / she] [G40=RETIREMENT PLAN, PENSION, IRA: [have / has] not begun to receive regular benefit payments but] expect[s] to receive benefits?

→ GO TO P70CKPT



P45A. [CYAQRTH, CYNAMF CYNAML]

How many such (pension or retirement) plans (through a former employer) [do you / does [he / she]] have from which [you / he /she] expect[s] to receive benefits?

P46. [CYAQRTH, CYNAMF CYNAML], Plan #[1 / 2] Through a Former Employer

1st PENSION FROM A FORMER EMPLOYER:

[HAS PENSION W/CURRENT EMPLOYER: What type of plan was this second pension or retirement plan? / NO PENSION W/CURRENT EMPLOYER: I would like to know what type of plan this was.] [SP LOOP: (] One that bases benefits on a formula involving age, years of service and salary, or one that bases benefits on how much money has accumulated in a person’s pension or retirement account, such as a 401K [SP LOOP:)]?

2nd PENSION FROM A FORMER EMPLOYER:

I would like to know what type of plan this was. (One that bases benefits on a formula involving age, years of service and salary, or one that bases benefits on how much money has accumulated in a person’s pension or retirement account, such as a 401K?)

- [P45A>1 PLAN: If needed: Tell us about the [2nd PENSION FROM FORMER EMPLOYER: next] most important plan]
- Defined Contribution plans include 401-K, 403-B, ESOP, SRA, thrift/savings, stock/profit sharing, money purchase plans, and target date funds (TDF)

1. Plan based on formula/ "Defined benefit" plan	5. Money accumulated in account/ "Defined contribution" plan	7. Both	DK	RF
GO TO P52	GO TO P62ACKPT	↓	GO TO P52	GO TO P70CKPT

Plan with Former Employer - Defined Contribution (P46=Both)

P47. [CYAQRTH, CYNAMF CYNAML], Plan #[1 / 2] Through a Former Employer

For the part of [your / his / her] pension or retirement plan where money is accumulated in an account, how much money was in [your / his / her] account when [you / he / she] left that employer?

\$ 0 – 99,999,997 → GO TO P48 DK/RF

↓

P47B. Was it \$20,000 or more?

1. Yes	5. No DK/RF → GO TO P48
↓	↓
P47C. \$50,000 or more?	
1. Yes 5. No DK/RF	
↓ GO TO P48	
P47D. \$150,000 or more?	
1. Yes 5. No DK/RF	

P47E. \$5,000 or more?	
1. Yes 5. No DK/RF	
GO TO P48	

P48. [CYAQRTH, CYNAMF CYNAML], Plan #[1 / 2] Through a Former Employer

When [you / he / she] left that employer, did [you / he / she] withdraw this money, roll it over into an I.R.A. (Individual Retirement Account), leave it to accumulate in the old plan, convert it to an annuity, or what?

- IF more than one response given, ENTER [7] and record all details

1. Withdrew the money	2. Rolled over into I.R.A.	3. Left to accumulate	4. Converted to annuity	7. Other-specify (P48SPEC. Specify. (String 100))	DK/RF
GO TO P52	↓		GO TO P50	GO TO P52	

P49. [CYAQRTH, CYNAMF CYNAML], Plan #[1 / 2] Through a Former Employer

How much is in [your / his / her] account now?

→ GO TO P52

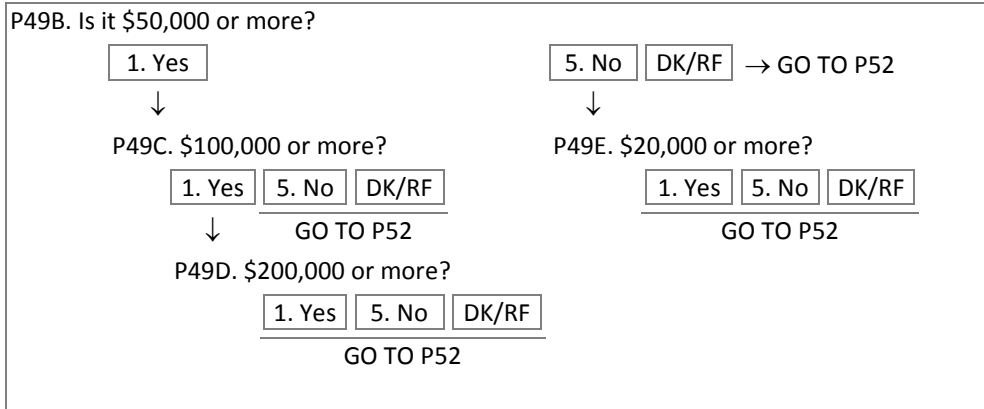

P50. [CYAQRTH, CYNAMF CYNAML], Plan #[1 / 2] Through a Former Employer

How old [were you / was [he / she]] when [you / he / she] started receiving the benefits from that annuity?

- IF benefits have not yet begun, PROBE: At what age will [you / he / she] begin receiving them?

P51. [CYAQRTH, CYNAMF CYNAML], Plan #[1 / 2] Through a Former Employer

How much are the annuity benefits per month or year?

- IF benefits have not yet begun, PROBE: What will the benefits be once [you / he / she] begin[s] receiving them?
- ENTER dollar amount here, then SELECT unit of time on next screen (Month, Year)

→ GO TO P51B



P51PER. The amount entered is: [P51] per ____

- SELECT the unit of time below

GO TO P52

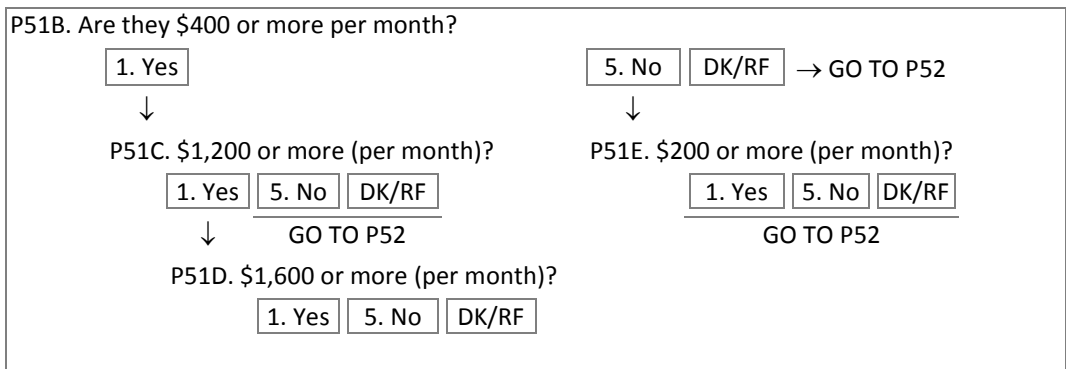

Plan with Former Employer - Defined Benefit (P46=DB Only or Both)

P52. [CYAQRTH, CYNAMF CYNAML], Plan #[1 / 2] Through a Former Employer

[P46=BOTH: Now about the part of [your / his / her] pension or retirement plan where benefits are based on a formula. / ALL OTHERS: (Now about the part of [your / his / her] pension or retirement plan where benefits are based on a formula.)]

[Do you / Does [RP / SP]] expect to receive benefits from this plan in the future, [are you / is [he / she]] receiving benefits now, did [you / he / she] get a cash settlement when [you / he / she] left, did [you / he / she] lose [your / his / her] benefits, or what?

- DO NOT PROBE for multiple responses but ENTER all that apply.

1. Expect future benefits	5. Lost benefits	7. Other-specify (P52SPEC. Specify. (String 100))	DK/RF
2. Receiving benefits now	GO TO P69		
3. Received cash settlement			
4. Rolled over into I.R.A.			



P52ACKPT. CAI Checkpoint: Whether Receiving Benefits & Reported Receiving Benefits Last Wave

Receiving Benefits (P52=2)		5. All Others
1. Ineligible for Dep IWing (P45A<>1 plan; or NEWPRELOAD.PP52<>2; or NEWPRELOAD.PP52=2 & (NEWPRELOAD.PPLANS>1 or NEWPRELOAD.PP53Yr=DK, RF))	2. Eligible for Dep IWing (P45A=1 plan & NEWPRELOAD.PP52=2 & NEWPRELOAD.PPLANS=1 & NEWPRELOAD.PP53Yr=Response)	GO TO P56ACKPT
↓		Assign P53YR=NEWPRELOAD.PP53YR; Then GO TO P54

Plan with Former Employer - Defined Benefit (P46=DB Only or Both)

Dependent Interviewing for Reinterviews

P53YR. [CYAQRTH, CYNAMF CYNAML], Plan #[1 / 2] Through a Former Employer

In what year did [you / he / she] start to receive these benefits?

- ENTER the year below

1901 – [CYEAR]

P54. [CYAQRTH, CYNAMF CYNAML], Plan #[1 / 2] Through a Former Employer

How much are the benefits per month or year?

- IF benefits have not yet begun, PROBE: What will the benefits be once [you / he / she] begin[s] receiving them?
- ENTER dollar amount here, then SELECT unit of time on next screen (Month, Year)

\$ 1 – 9,999,997 DK/RF → GO TO P54B



P54PER. The amount entered is: [P54] per ____

- SELECT the unit of time below

5. Month 6. Year 7. Other-specify (P54PERSPEC. Specify. (String 100))

GO TO P56ACKPT

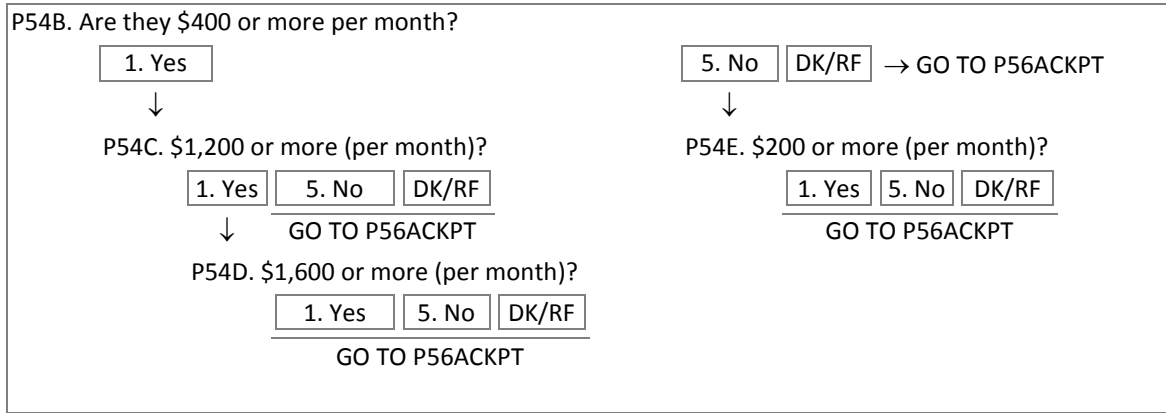

P56ACKPT. CAI Checkpoint: Whether Received Cash Settlement

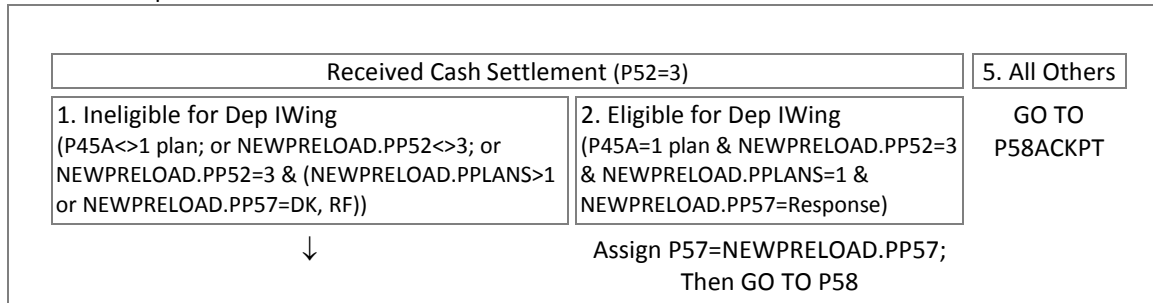

Plan with Former Employer - Defined Benefit (P46=DB Only or Both)

Dependent Interviewing for Reinterviews

P57. [\[CYAQRTH, CYNAMF CYNAML\]](#), [Plan #\[1 / 2\] Through a Former Employer](#)

How much did that cash settlement amount to?

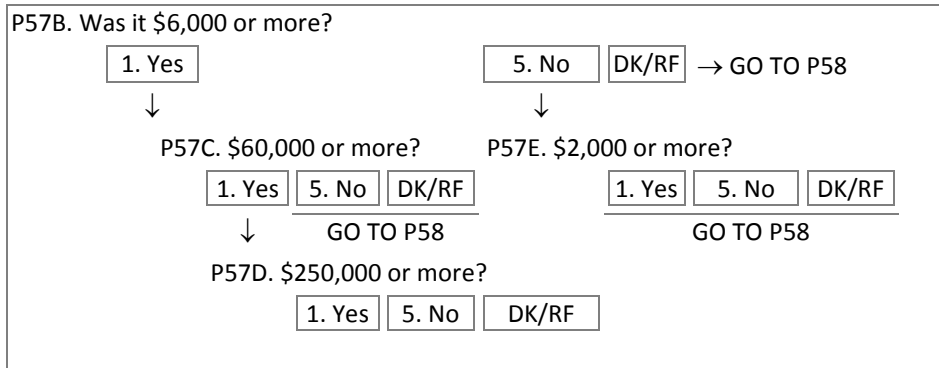
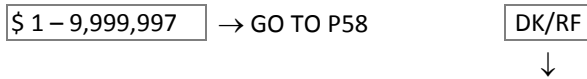

P58. [\[CYAQRTH, CYNAMF CYNAML\]](#), [Plan #\[1 / 2\] Through a Former Employer](#)

What did [you / he / she] do with the money?

- **ENTER** all that apply
- **PROBE:** Any others?

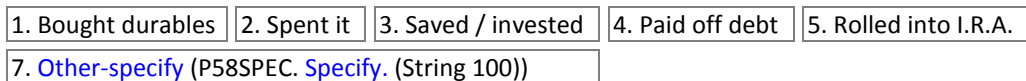

P58ACKPT. CAI CHECKPOINT: Whether Rolled Into IRA

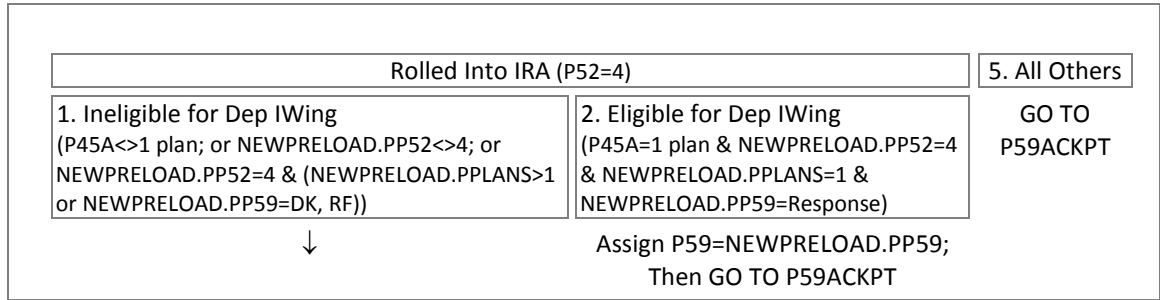

Plan with Former Employer - Defined Benefit (P46=DB Only or Both)

Dependent Interviewing for Reinterviews

P59. [CYAQRTH, CYNAMF CYNAML], Plan #[1 / 2] Through a Former Employer

How much did that I.R.A. (Individual Retirement Account) rollover amount to?

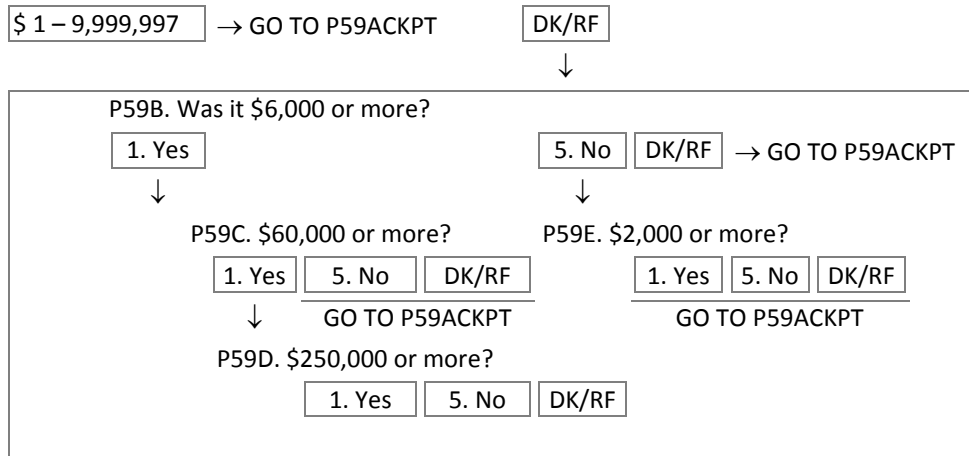

P59ACKPT. CAI Checkpoint: Whether Expects Benefits

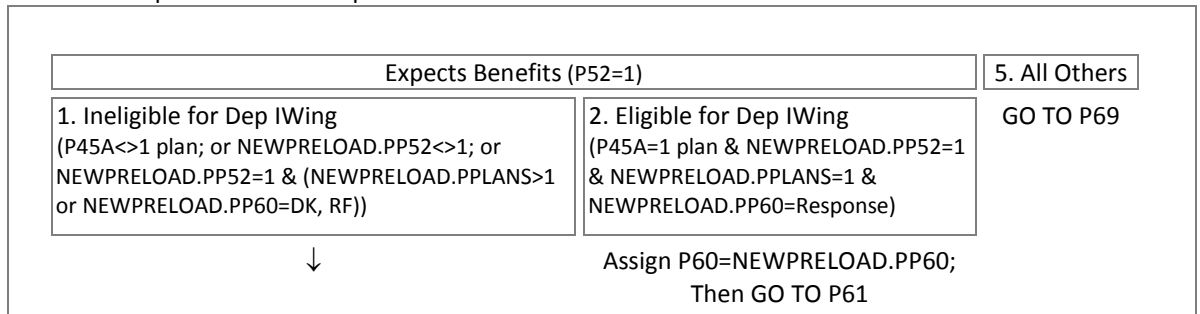

Plan with Former Employer - Defined Benefit (P46=DB Only or Both)

Dependent Interviewing for Reinterviews

P60. [CYAQRTH, CYNAMF CYNAML], Plan #[1 / 2] Through a Former Employer

For how many years altogether [were you / was [he / she]] included in this plan?

- INCLUDE years with other employers if same plan.

1 – 50

P61. **[CYAQRTH, CYNAMF CYNAML], Plan #[1 / 2] Through a Former Employer**

At what age [do you / does [he / she]] expect to start receiving (the rest of [your / his / her]) benefits from this plan?

- ENTER [97] if already receiving all benefits

[CURRENT AGE] - 75 97. Already receiving all benefits → GO TO P62ACKPT DK/RF

↓

P62AMT. **[CYAQRTH, CYNAMF CYNAML], Plan #[1 / 2] Through a Former Employer**

How much [do you / does [he / she]] expect to receive (, either as a percent of [your / his / her] pay when [you / he / she] left that job or as an amount per month or year)?

- ENTER dollar amount here, then SELECT unit of time on next screen (Month, Year)
- OR press [ENTER] to continue to next screen for Percent

[ENTER] → GO TO P62PCT \$ 1 - 999,997 DK/RF → GO TO P62F

↓

P62PER. The amount entered is: [P62AMT] per ____

- SELECT the unit of time below

5. Month 6. Year 7. Other-specify (P62PERSPEC. Specify. (String 100))

GO TO P62ACKPT

P62PCT. **[CYAQRTH, CYNAMF CYNAML], Plan #[1 / 2] Through a Former Employer**

(How much [do you / does [he / she]] expect to receive (, as a percent of [your / his / her] pay when [you / he / she] left that job)?)

- ENTER a percentage from 1.0 to 100.0

1.0 - 100.0 → GO TO P62KCKPT DK/RF

↓

P62F. Will it be 40% of [your / his / her] pay or more?

1. Yes 5. No DK/RF → GO TO P62KCKPT

↓

P62G. 60% or more (of [your / his / her] pay)? P62J. 20% or more (of [your / his / her] pay)?

1. Yes 5. No DK/RF 1. Yes 5. No DK/RF

↓ GO TO P62KCKPT ↓ GO TO P62KCKPT

P62H. 80% or more (of [your / his / her] pay)?

1. Yes 5. No DK/RF

P62KCKPT. CAI Checkpoint: Whether P62PCT or P62F-P62J is Response

1. P62PCT=Response 2. P62F, P62G, P62H or P62J=Response 5. All Others

↓ GO TO P62ACKPT

P62K. **[CYAQRTH, CYNAMF CYNAML], Plan #[1 / 2] Through a Former Employer**

And what was [your / his / her] pay when [you / he / she] left that job)?

\$ 1 - 9,999,997.99 DK/RF → GO TO P62ACKPT

↓

P62KPER. The amount entered is: [P62K] per ____

- SELECT the unit of time below

1. Hour	2. Day	3. Week	4. Two Weeks	5. Month	6. Year
7. Other-specify (P62KPERSPEC. Specify. (String 100))					

P62ACKPT. CAI Checkpoint: Whether Pension Is DB Only or DC Only

1. DB Only (P46=1)	3. DC Only (P46=5)	5. All Others (P46=7 or DK/RF)
GO TO P69	↓	GO TO P69

Plan with Former Employer - Defined Contribution (P46=DC Only)

P63. [CYAQRTH, CYNAMF CYNAML], Plan #[1 / 2] Through a Former Employer

How much money was in [your / his / her] account when [you / he / she] left that employer?

\$ 1 – 9,999,997 → GO TO P64	DK/RF
------------------------------	-------

↓

P63B. Was it \$20,000 or more?	
1. Yes	5. No DK/RF → GO TO P64
↓	↓
P63C. \$50,000 or more?	P63E. \$5,000 or more?
1. Yes 5. No DK/RF	1. Yes 5. No DK/RF
↓ GO TO P64	↓ GO TO P64
P63D. \$150,000 or more?	
1. Yes 5. No DK/RF	

P64. [CYAQRTH, CYNAMF CYNAML], Plan #[1 / 2] Through a Former Employer

When [you / he / she] left that employer, did [you / he / she] transfer [your / his / her] account to a new employer, roll it over into an I.R.A. (Individual Retirement Account), leave it to accumulate in [your / his / her] old plan, convert it to an annuity or what?

- If more than one response given, ENTER [7] and record all details

1. Transferred to new employer	2. Rolled over into I.R.A.	3. Left to accumulate	4. Converted to annuity	7. Other-specify (P64SPEC. Specify. (String 100))	DK/RF
GO TO P69	↓	GO TO P66	GO TO P69	GO TO P69	

P65. [CYAQRTH, CYNAMF CYNAML], Plan #[1 / 2] Through a Former Employer

How much is in [your / his / her] account now?

→ GO TO P69

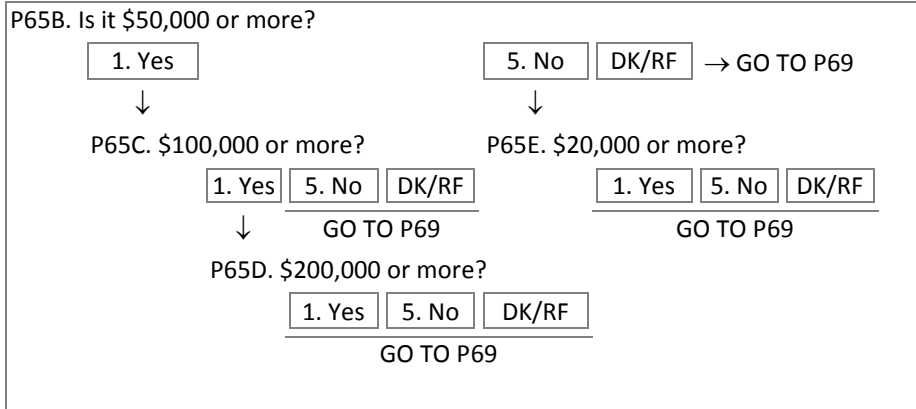

P66. [CYAQRTH, CYNAMF CYNAML], Plan #[1 / 2] Through a Former Employer

How old [were you / was [he / she]] when [you / he / she] started receiving the benefits from that annuity?

- IF benefits have not yet begun, PROBE: At what age will [you / he / she] begin receiving them?

P67. [CYAQRTH, CYNAMF CYNAML], Plan #[1 / 2] Through a Former Employer

How much are the annuity benefits per month or year?

- IF benefits have not yet begun, PROBE: What will the benefits be once [you / he / she] begin[s] receiving them?
- ENTER dollar amount here, then SELECT unit of time on next screen (Month, Year)

→ GO TO P67B



P67PER. The amount entered is: [P67] per ____

- SELECT the unit of time below

GO TO GO TO P69

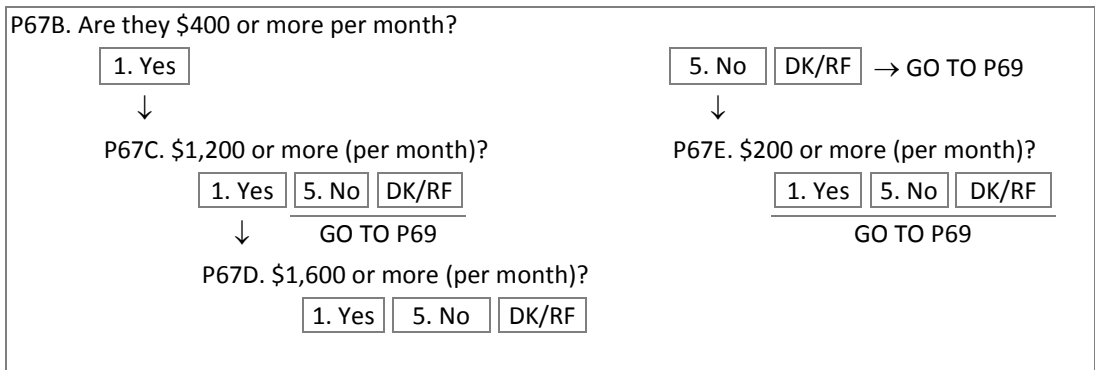

P69. [CYAQRTH, CYNAMF CYNAML]

[Do you / Does [RP / SP]] have any other pensions or retirement plans from a former employer (that you haven't already told me about)?

- 1. Yes → Repeat P46-P68; MAX=2; Then GO TO P70CKPT
- 5. No → GO TO P70CKPT

SIGNAL for P69<>YES & P45A=2-5: Earlier R reported more than one pension plan from a previous employer. Please verify. If R verifies more than one pension plan from a previous employer, select CLOSE and ENTER [1] at this question. If R verifies just one pension plan from a previous employer, select SUPPRESS to continue

END P45_P69

END SECTION_PDETAIL

P70CKPT. CAI Checkpoint: Whether Spouse/Partner in FU

1. Spouse/Partner (CYFUHU=FU, FUMI & CYAQRTH=201-222)	5. No Spouse/Partner → GO TO SECTION H
↓	

P70ACKPT. CAI Checkpoint: Employment Status of Spouse/Partner

1. Working Now (BCDE1=1, 2 or BCDE3=Yes) Repeat SECTION P; Then GO TO SECTION H	Not Working Now (BCDE3=No, DK/RF)		
2. Never Worked (BCDE3A=No, DK/RF & BC62=No, DK/RF) GO TO SECTION H	Has Worked (BCDE3A=Yes or (BCDE3A=No, DK/RF & BC62=Yes))		5. Unemployed, DK/RF (BCDE1=3, DK/RF) Repeat P42CKPT-P69; Then GO TO SECTION H
3. Retired, Disabled, Keep House, Student, Other (BCDE1=4-8) Repeat P45-P69; Then GO TO SECTION H			

END SECTION_P

Section H: Health

[TOC](#)

SECTION_H

SECTION_H.H1_H23 [1-2] [1]=Current Reference Person, [2]=Current Spouse/Partner

AQSN. AQSN of Current Reference Person (Spouse/Partner)

General Health - Reference Person and Spouse/Partner

H1. [CYNAMF CYNAML]: [CYAQRTH], [CYFUHU], Age [AGEIWDATE]

Now I have a few questions about [your / [RP / SP]'s] health.

Would you say [your / [RP / SP]'s] health in general is excellent, very good, good, fair, or poor?

H1A. [CYNAMF CYNAML]: [CYAQRTH], [CYFUHU], Age [AGEIWDATE]

[RETURNING RP/SP: Since we last talked to you about [your / his / her] health, / NEW RP/SP, IMMIG: Compared to [your / his / her] health say, two years ago,] would you say that [your / his / her] health is better now, about the same, or worse?

 → GO TO H2

H1B. [CYNAMF CYNAML]: [CYAQRTH], [CYFUHU],
Age [AGEIWDATE]
Is it much better or somewhat better?

 → GO TO H2

H1C. [CYNAMF CYNAML]: [CYAQRTH], [CYFUHU],
Age [AGEIWDATE]
Is it much worse or somewhat worse?

Chronic Conditions - Reference Person and Spouse/Partner

H2. [CYNAMF CYNAML]: [CYAQRTH], [CYFUHU], Age [AGEIWDATE]

[Do you / Does [RP / SP]] have any physical or nervous condition that limits the type of work or the amount of work [you / he / she] can do?

 → GO TO H5A

H3. [CYNAMF CYNAML]: [CYAQRTH], [CYFUHU], Age [AGEIWDATE]

Does this condition keep [you / [RP / SP]] from doing some types of work?

 → GO TO H5A



H4. [CYNAMF CYNAML]: [CYAQRTH], [CYFUHU], Age [AGEIWDATE]

For work [you / [RP / SP]] can do, how much does it limit the amount of work [you / [RP / SP]] can do - a lot, somewhat, or just a little?

H5A. [CYNAMF CYNAML]: [CYAQRTH], [CYFUHU], Age [AGEIWDATE]

These next questions ask you about health conditions that a doctor or other health professional has EVER told [you / [RP / SP]] that [you have / [he / she] has] or had in [your / his / her] lifetime.

Has a doctor or other health professional EVER told [you / [RP / SP]] that [you / he / she] had...

A stroke?

1. Yes 5. No → GO TO H5B



H6A1. [CYNAMF CYNAML]: [CYAQRTH], [CYFUHU], Age [AGEIWDATE]

How old [were you / was [RP / SP]] the first time [you / he / she] had a stroke?

- ENTER [995] for less than 1 year

1 – [CURRENT AGE] 995. Less than one year old (IF VOL)

H6A2. [CYNAMF CYNAML]: [CYAQRTH], [CYFUHU], Age [AGEIWDATE]

[Have you / Has [he / she]] had [RETURNING RP/SP & (H6A1=995 or Age minus H6A1>[REINT, SO, RECLONG: 2 YRS / RECON, RECSO: 4 YRS]: another stroke since our last interview in [REINT, SO, RECLONG: [P2YEAR] / RECON, RECSO: [P4YEAR]] [PYIWDATE=RESPONSE: ([PYIWDATE]])] / ALL OTHERS (IMMIG, or REINT, RECON, RECLONG & (H6A1=DK/RF or Age minus H6A1<[2/4 YRS]): a second or subsequent stroke since that first one]?

1. Yes 5. No

H7A. [CYNAMF CYNAML]: [CYAQRTH], [CYFUHU], Age [AGEIWDATE]

How much does this condition limit [your / his / her] normal daily activities? A lot, somewhat, just a little, or not at all?

1. A lot 3. Somewhat 5. Just a little 7. Not at all

H7A2. [CYNAMF CYNAML]: [CYAQRTH], [CYFUHU], Age [AGEIWDATE]

[Are you / Is [RP / SP]] now taking medication because of [your / his / her] stroke or its complications?

1. Yes 5. No

H5B. [CYNAMF CYNAML]: [CYAQRTH], [CYFUHU], Age [AGEIWDATE]

(Has a doctor or other health professional EVER told [you / [RP / SP]] that [you / he / she] had...)

A heart attack?

1. Yes 5. No → GO TO H5C



H6B1. [CYNAMF CYNAML]: [CYAQRTH], [CYFUHU], Age [AGEIWDATE]

How old [were you / was [RP / SP]] the first time [you / he / she] had a heart attack?

- ENTER [995] for less than 1 year

1 – [CURRENT AGE] 995. Less than one year old (IF VOL)

H6B2. [CYNAMF CYNAML]: [CYAQRTH], [CYFUHU], Age [AGEIWDATE]

[Have you / Has [he / she]] had [RETURNING RP/SP & (H6B1=995 or Age minus H6B1>[REINT, SO, RECLONG: 2 YRS / RECON, RECSO: 4 YRS]: another heart attack since our last interview in [REINT, SO, RECLONG: [P2YEAR] / RECON, RECSO: [P4YEAR]] [PYIWDATE=RESPONSE: ([PYIWDATE]])] / ALL OTHERS (IMMIG, or REINT, RECON, RECLONG & (H6B1=DK/RF or Age minus H6B1<[2/4 YRS]): a second or subsequent heart attack since that first one]?

1. Yes 5. No

H7B. [CYNAMF CYNAML]: [CYAQRTH], [CYFUHU], Age [AGEIWDATE]

How much does this condition limit [your / his / her] normal daily activities? A lot, somewhat, just a little, or not at all?

H7B2. [CYNAMF CYNAML]: [CYAQRTH], [CYFUHU], Age [AGEIWDATE]

[Are you / Is [RP / SP]] now taking or carrying medication because of [your / his / her] heart attack?

H5C. [CYNAMF CYNAML]: [CYAQRTH], [CYFUHU], Age [AGEIWDATE]

(Has a doctor or other health professional **EVER** told [you / [RP / SP]] that [you / he / she] had ...)
Coronary heart disease, angina, or congestive heart failure?

→ GO TO H5D

↓

H6C1. [CYNAMF CYNAML]: [CYAQRTH], [CYFUHU], Age [AGEIWDATE]

How old [were you / was [RP / SP]] when [you were / [he / she] was] first diagnosed with (this condition / any of these conditions)?

- ENTER [995] for less than 1 year

H7C. [CYNAMF CYNAML]: [CYAQRTH], [CYFUHU], Age [AGEIWDATE]

How much does this condition limit [your / his / her] normal daily activities? A lot, somewhat, just a little, or not at all?

H7C2. [CYNAMF CYNAML]: [CYAQRTH], [CYFUHU], Age [AGEIWDATE]

[Are you / Is [RP / SP]] now taking or carrying medication for [your / his / her] coronary heart disease, angina or congestive heart failure?

H5D. [CYNAMF CYNAML]: [CYAQRTH], [CYFUHU], Age [AGEIWDATE]

(Has a doctor or other health professional **EVER** told [you / [RP / SP]] that [you / he / she] had ...)
High blood pressure or hypertension?

→ GO TO H5E

↓

H6D1. [CYNAMF CYNAML]: [CYAQRTH], [CYFUHU], Age [AGEIWDATE]

How old [were you / was [RP / SP]] when [you were / [he / she] was] first diagnosed with high blood pressure or hypertension?

- ENTER [995] for less than 1 year

H7D. [CYNAMF CYNAML]: [CYAQRTH], [CYFUHU], Age [AGEIWDATE]

How much does this condition limit [your / his / her] normal daily activities? A lot, somewhat, just a little, or not at all?

H7D2. [CYNAMF CYNAML]: [CYAQRTH], [CYFUHU], Age [AGEIWDATE]

[Are you / Is [RP / SP]] now taking medication to lower [your / his / her] blood pressure?

1. Yes 5. No

H5E. [CYNAMF CYNAML]: [CYAQRTH], [CYFUHU], Age [AGEIWDATE]

(Has a doctor or other health professional EVER told [you / [RP / SP]] that [you / he / she] had ...)
Asthma?

1. Yes 5. No → GO TO H5F

↓

H6E1. How old [were you / was [RP / SP]] when [you were / [he / she] was] first diagnosed with asthma?

- ENTER [995] for less than 1 year

1 – [CURRENT AGE] 995. Less than one year old (IF VOL)

H7E. [CYNAMF CYNAML]: [CYAQRTH], [CYFUHU], Age [AGEIWDATE]

How much does this condition limit [your / his / her] normal daily activities? A lot, somewhat, just a little, or not at all?

1. A lot 3. Somewhat 5. Just a little 7. Not at all

H7E2. [CYNAMF CYNAML]: [CYAQRTH], [CYFUHU], Age [AGEIWDATE]

In order to treat or control [your / his / her] asthma, [are you / is [RP / SP]] now taking or carrying medication or an inhaler?

1. Yes 5. No

H5F. [CYNAMF CYNAML]: [CYAQRTH], [CYFUHU], Age [AGEIWDATE]

(Has a doctor or other health professional EVER told [you / [RP / SP]] that [you / he / she] had ...)
Chronic lung disease such as bronchitis or emphysema?

1. Yes 5. No → GO TO H5G

↓

H6F1. [CYNAMF CYNAML]: [CYAQRTH], [CYFUHU], Age [AGEIWDATE]

How old [were you / was [RP / SP]] when [you were / [he / she] was] first diagnosed with (lung disease / bronchitis / emphysema)?

- ENTER [995] for less than 1 year

1 – [CURRENT AGE] 995. Less than one year old (IF VOL)

H7F. [CYNAMF CYNAML]: [CYAQRTH], [CYFUHU], Age [AGEIWDATE]

How much does this condition limit [your / his / her] normal daily activities? A lot, somewhat, just a little, or not at all?

1. A lot 3. Somewhat 5. Just a little 7. Not at all

H7F2. [CYNAMF CYNAML]: [CYAQRTH], [CYFUHU], Age [AGEIWDATE]

[Are you / Is [RP / SP]] now taking medication or receiving oxygen or other treatment for [your / his / her] lung condition?

1. Yes 5. No

H5G. [CYNAMF CYNAML]: [CYAQRTH], [CYFUHU], Age [AGEIWDATE]

(Has a doctor or other health professional EVER told [you / [RP / SP]] that [you / he / she] had ...)
Diabetes or high blood sugar?

1. Yes 5. No → GO TO H5H



H6G1. [CYNAMF CYNAML]: [CYAQRTH], [CYFUHU], Age [AGEIWDATE]

How old [were you / was [RP / SP]] when [you were / [he / she] was] first diagnosed with diabetes?

- ENTER [995] for less than 1 year

1 – [CURRENT AGE] 995. Less than one year old (IF VOL)

H7G. [CYNAMF CYNAML]: [CYAQRTH], [CYFUHU], Age [AGEIWDATE]

How much does this condition limit [your / his / her] normal daily activities? A lot, somewhat, just a little, or not at all?

1. A lot 3. Somewhat 5. Just a little 7. Not at all

H7G2. [CYNAMF CYNAML]: [CYAQRTH], [CYFUHU], Age [AGEIWDATE]

In order to treat or control [your / his / her] diabetes, [are you / is [RP / SP]] now taking medication that [you / he / she] swallow[s] or using insulin shots or a pump?

1. Yes 5. No

H5H. [CYNAMF CYNAML]: [CYAQRTH], [CYFUHU], Age [AGEIWDATE]

(Has a doctor or other health professional EVER told [you / [RP / SP]] that [you / he / she] had ...)
Arthritis or rheumatism?

1. Yes 5. No → GO TO H5I



H6H1. [CYNAMF CYNAML]: [CYAQRTH], [CYFUHU], Age [AGEIWDATE]

How old [were you / was [RP / SP]] when [you were / [he / she] was] first diagnosed with (arthritis / rheumatism)?

- ENTER [995] for less than 1 year

1 – [CURRENT AGE] 995. Less than one year old (IF VOL)

H7H. [CYNAMF CYNAML]: [CYAQRTH], [CYFUHU], Age [AGEIWDATE]

How much does this condition limit [your / his / her] normal daily activities? A lot, somewhat, just a little, or not at all?

1. A lot 3. Somewhat 5. Just a little 7. Not at all

H7H2. [CYNAMF CYNAML]: [CYAQRTH], [CYFUHU], Age [AGEIWDATE]

[Are you / Is [RP / SP]] now taking medication or receiving treatment for [your / his / her] arthritis or rheumatism?

1. Yes 5. No

H5I. [CYNAMF CYNAML]: [CYAQRTH], [CYFUHU], Age [AGEIWDATE]

(Has a doctor or other health professional EVER told [you / [RP / SP]] that [you / he / she] had ...)
Permanent loss of memory or loss of mental ability?

1. Yes 5. No → GO TO H5J



H6I1. [CYNAMF CYNAML]: [CYAQRTH], [CYFUHU], Age [AGEIWDATE]

How old [were you / was [RP / SP]] when [you were / [he / she] was] first diagnosed with (loss of memory / mental ability)?

- ENTER [995] for less than 1 year

1 – [CURRENT AGE] 995. Less than one year old (IF VOL)

H7I. [CYNAMF CYNAML]: [CYAQRTH], [CYFUHU], Age [AGEIWDATE]

How much does this condition limit [your / his / her] normal daily activities? A lot, somewhat, just a little, or not at all?

1. A lot 3. Somewhat 5. Just a little 7. Not at all

H7I2. [CYNAMF CYNAML]: [CYAQRTH], [CYFUHU], Age [AGEIWDATE]

[Are you / Is [RP / SP]] now taking medication prescribed by a doctor to help with [your / his / her] memory problem?

1. Yes 5. No

H5J. [CYNAMF CYNAML]: [CYAQRTH], [CYFUHU], Age [AGEIWDATE]

(Has a doctor or other health professional EVER told [you / [RP / SP]] that [you / he / she] had...)
A learning disorder?

1. Yes 5. No → GO TO H5K



H6J1. [CYNAMF CYNAML]: [CYAQRTH], [CYFUHU], Age [AGEIWDATE]

How old [were you / was [RP / SP]] when [you were / [he / she] was] first diagnosed with a learning disorder?

- ENTER [995] for less than 1 year

1 – [CURRENT AGE] 995. Less than one year old (IF VOL)

H7J. [CYNAMF CYNAML]: [CYAQRTH], [CYFUHU], Age [AGEIWDATE]

How much does this condition limit [your / his / her] normal daily activities? A lot, somewhat, just a little, or not at all?

1. A lot 3. Somewhat 5. Just a little 7. Not at all

H7J2. [CYNAMF CYNAML]: [CYAQRTH], [CYFUHU], Age [AGEIWDATE]

[Are you / Is [RP / SP]] now receiving treatment or taking medication to help with [your / his / her] learning disorder?

1. Yes 5. No

H5K. [CYNAMF CYNAML]: [CYAQRTH], [CYFUHU], Age [AGEIWDATE]

(Has a doctor or other health professional EVER told [you / [RP / SP]] that [you / he / she] had ...)
Cancer or a malignant tumor?

1. Yes 5. No → GO TO H5L



H6K1. [CYNAMF CYNAML]: [CYAQRTH], [CYFUHU], Age [AGEIWDATE]

How old [were you / was [RP / SP]] when [you were / [he / she] was] first diagnosed with cancer?

- ENTER [995] for less than 1 year

1 – [CURRENT AGE] 995. Less than one year old (IF VOL)

H6K3. [CYNAMF CYNAML]: [CYAQRTH], [CYFUHU], Age [AGEIWDATE]

[Are you / Is [RP / SP]] currently in treatment for [your / his / her] cancer, in remission, or has it been cured?

- If R says can't afford insurance to get treatment, are doing nothing, etc, ENTER: [4]

1. Treatment 2. Remission 3. Cured 4. Not getting treatment (IF VOL)

H6K4. [CYNAMF CYNAML]: [CYAQRTH], [CYFUHU], Age [AGEIWDATE]

What type of cancer [do you / does [he / she]] have? (In what part of [your / his / her] body is it?)

- ENTER all that apply
- PROBE: Any others?

<input type="text"/> 1. Bladder cancer	<input type="text"/> 2. Breast cancer	<input type="text"/> 3. Cervical cancer
<input type="text"/> 4. Colon cancer	<input type="text"/> 5. Lung cancer	<input type="text"/> 6. Lymphoma or leukemia
<input type="text"/> 7. Ovarian cancer	<input type="text"/> 8. Prostate cancer	<input type="text"/> 9. Skin cancer, Melanoma
<input type="text"/> 10. Skin cancer, non-melanoma (e.g. basal cell)	<input type="text"/> 11. Skin cancer, DK type	
<input type="text"/> 12. Thyroid cancer	<input type="text"/> 13. Uterine cancer	<input type="text"/> 97. Other-specify (H6K4SPEC. Specify (String 100))

H7K. [CYNAMF CYNAML]: [CYAQRTH], [CYFUHU], Age [AGEIWDATE]

How much does this condition limit [your / his / her] normal daily activities? A lot, somewhat, just a little, or not at all?

1. A lot 3. Somewhat 5. Just a little 7. Not at all

H5L. [CYNAMF CYNAML]: [CYAQRTH], [CYFUHU], Age [AGEIWDATE]

(Has a doctor or other health professional EVER told [you / [RP / SP]] that [you / he / she] had ...)
Any emotional, nervous, or psychiatric problems?

1. Yes 5. No → GO TO H5M



H6L1. [CYNAMF CYNAML]: [CYAQRTH], [CYFUHU], Age [AGEIWDATE]

How old [were you / was [RP / SP]] when [you were / [he / she] was] first diagnosed?

- ENTER [995] for less than 1 year

1 – [CURRENT AGE] 995. Less than one year old (IF VOL)

H6L2. [CYNAMF CYNAML]: [CYAQRTH], [CYFUHU], Age [AGEIWDATE]

What was the diagnosis? What is the emotional / psychiatric disorder?

- ENTER all that apply
- PROBE: Any others?

1. Depression	2. Bipolar disorder (mania)	3. Schizophrenia (psychosis)
4. Anxiety (panic)	5. Phobias	6. Alcohol use / abuse (alcoholism)
7. Drug use / abuse (drug addiction)	8. Obsessive compulsive	
9. PTSD (Post-Traumatic Stress Disorder)	97. Other-specify (H6L2SPEC. Specify (String 100))	

H7L. [CYNAMF CYNAML]: [CYAQRTH], [CYFUHU], Age [AGEIWDATE]

How much does this condition limit [your / his / her] normal daily activities? A lot, somewhat, just a little, or not at all?

1. A lot	3. Somewhat	5. Just a little	7. Not at all
----------	-------------	------------------	---------------

H7L2. [CYNAMF CYNAML]: [CYAQRTH], [CYFUHU], Age [AGEIWDATE]

[Are you / Is [RP / SP]] taking tranquilizers, antidepressants, or pills for nerves?

1. Yes	5. No
--------	-------

H5M. [CYNAMF CYNAML]: [CYAQRTH], [CYFUHU], Age [AGEIWDATE]

Is there any other serious, chronic condition that a doctor or other health professional EVER told [you / [RP / SP]] that [you / he / she] had?

1. Yes	5. No	→ GO TO H5NCKPT
--------	-------	-----------------

↓

H6M1. [CYNAMF CYNAML]: [CYAQRTH], [CYFUHU], Age [AGEIWDATE]

What is that condition?

String 500

H6M2. [CYNAMF CYNAML]: [CYAQRTH], [CYFUHU], Age [AGEIWDATE]

How old [were you / was [RP / SP]] when [you were / [he / she] was] first diagnosed?

- ENTER [995] for less than 1 year

1 – [CURRENT AGE]	995. Less than one year old (IF VOL)
-------------------	--------------------------------------

H7M. [CYNAMF CYNAML]: [CYAQRTH], [CYFUHU], Age [AGEIWDATE]

How much does this condition limit [your / his / her] normal daily activities? A lot, somewhat, just a little, or not at all?

1. A lot	3. Somewhat	5. Just a little	7. Not at all
----------	-------------	------------------	---------------

H7M2. [CYNAMF CYNAML]: [CYAQRTH], [CYFUHU], Age [AGEIWDATE]

[Are you / Is [RP / SP]] now taking medication for this condition?

1. Yes	5. No
--------	-------

Dementia Screener - Reference Person and Spouse/Partner Age 65 or Older

H5N2–H5N9: All rights reserved. Copyright 2008 by Washington University in St. Louis, Missouri.

H5NCKPT. CAI Checkpoint: Whether 65 Years Old or Older

1. Age 65 or Older (AGEIWDATE=65+)	5. Age Less Than 65 (AGEIWDATE<65 or DK/RF)	→ GO TO H8
↓		

H5N2. [CYNAMF CYNAML]: [CYAQRTH], [CYFUHU], Age [AGEIWDATE]

Next, we'd like to know about changes that [you / [RP / SP]] may have had in the last several years [*THIS PERSON IS NOT R: because of a thinking or memory problem*].

In the last several years, has there been a change in problems [you / he / she] may have with judgment, for example, problems making decisions, making bad financial decisions, or with thinking?

1. Yes, a change 5. No, no change

H5N3. [CYNAMF CYNAML]: [CYAQRTH], [CYFUHU], Age [AGEIWDATE]

In the last several years, has there been a change in...

The amount of interest [you / he / she] may have in hobbies or activities?

1. Yes, a change 5. No, no change

H5N4. [CYNAMF CYNAML]: [CYAQRTH], [CYFUHU], Age [AGEIWDATE]

(In the last several years, has there been a change in...)

[Your / His / Her] repeating the same things over and over, such as questions, stories, or statements?

1. Yes, a change 5. No, no change

H5N5. [CYNAMF CYNAML]: [CYAQRTH], [CYFUHU], Age [AGEIWDATE]

(In the last several years, has there been a change in ...)

The trouble [you / he / she] may have learning how to use a tool, appliance or gadget like a TV remote?

1. Yes, a change 5. No, no change

H5N6. [CYNAMF CYNAML]: [CYAQRTH], [CYFUHU], Age [AGEIWDATE]

(In the last several years, has there been a change in ...)

[Your / His / Her] forgetting the correct month or year?

1. Yes, a change 5. No, no change

H5N7. [CYNAMF CYNAML]: [CYAQRTH], [CYFUHU], Age [AGEIWDATE]

(In the last several years, has there been a change in...)

The trouble [you / he / she] may have handling complicated money matters, like balancing a checkbook or paying bills?

1. Yes, a change 5. No, no change

H5N8. [CYNAMF CYNAML]: [CYAQRTH], [CYFUHU], Age [AGEIWDATE]

(In the last several years, has there been a change in...)

The trouble [you / he / she] may have remembering appointments?

1. Yes, a change 5. No, no change

H5N9. [CYNAMF CYNAML]: [CYAQRTH], [CYFUHU], Age [AGEIWDATE]
 (In the last several years, has there been a change in...)
 Daily problems [you / he / she] may have with thinking and/or memory?

Hospital Stays - Reference Person and Spouse/Partner

H8. [CYNAMF CYNAML]: [CYAQRTH], [CYFUHU], Age [AGEIWDATE]
 [Were you / Was [RP / SP]] a patient in a hospital overnight or longer at any time during [PYEAR]?
 → GO TO H8A3
 ↓
 H8A. [CYNAMF CYNAML]: [CYAQRTH], [CYFUHU], Age [AGEIWDATE]
 How many nights [were you / was [RP / SP]] in a hospital altogether in [PYEAR]?
 • ENTER amount here, then SELECT unit of time on next screen (Nights, Weeks)
 → GO TO H8A3
 ↓
 H8A2. [CYNAMF CYNAML]: [CYAQRTH], [CYFUHU], Age [AGEIWDATE]
 The amount entered is: [H8A]
 • SELECT the unit of time below

Lower Body Functionality - Reference Person and Spouse/Partner

H8A3. (H5 1986) [CYNAMF CYNAML]: [CYAQRTH], [CYFUHU], Age [AGEIWDATE]
 [Do you / Does [he / she]] have any trouble either walking several blocks or climbing a few flights of stairs, because of [your / his / her] health?

H8A4. (H6 1986) [CYNAMF CYNAML]: [CYAQRTH], [CYFUHU], Age [AGEIWDATE]
 [Do you / Does [he / she]] have trouble bending, lifting, or stooping because of [your / his / her] health?

Activities of Daily Living (ADL) - Reference Person and Spouse/Partner

H9A. [CYNAMF CYNAML]: [CYAQRTH], [CYFUHU], Age [AGEIWDATE]
 The next questions are about [your / [RP / SP]'s] ability to do certain activities - by [yourself / himself / herself] and without special equipment.
 Because of a health or physical problem, [do you / does [he / she]] have any difficulty bathing or showering?
 → GO TO H9B
 ↓
 H10A1. [CYNAMF CYNAML]: [CYAQRTH], [CYFUHU], Age [AGEIWDATE]
 Does someone usually help [you / him / her] with that activity?

H10A2. [CYNAMF CYNAML]: [CYAQRTH], [CYFUHU], Age [AGEIWDATE]
 [Do you / Does [he / she]] usually use special equipment to do that activity?

H9B. [CYNAMF CYNAML]: [CYAQRTH], [CYFUHU], Age [AGEIWDATE]

(Because of a health or physical problem, [do you / does [he / she]] have any difficulty...)

Dressing?

1. Yes 5. No → GO TO H9C



H10B1. [CYNAMF CYNAML]: [CYAQRTH], [CYFUHU], Age [AGEIWDATE]

Does someone usually help [you / him / her] with that activity?

1. Yes 5. No

H10B2. [CYNAMF CYNAML]: [CYAQRTH], [CYFUHU], Age [AGEIWDATE]

[Do you / Does [he / she]] usually use special equipment to do that activity?

1. Yes 5. No

H9C. [CYNAMF CYNAML]: [CYAQRTH], [CYFUHU], Age [AGEIWDATE]

(Because of a health or physical problem, [do you / does [he / she]] have any difficulty...)

Eating?

1. Yes 5. No → GO TO H9D



H10C1. [CYNAMF CYNAML]: [CYAQRTH], [CYFUHU], Age [AGEIWDATE]

Does someone usually help [you / him / her] with that activity?

1. Yes 5. No

H10C2. [CYNAMF CYNAML]: [CYAQRTH], [CYFUHU], Age [AGEIWDATE]

[Do you / Does [he / she]] usually use special equipment to do that activity?

1. Yes 5. No

H9D. [CYNAMF CYNAML]: [CYAQRTH], [CYFUHU], Age [AGEIWDATE]

(Because of a health or physical problem, [do you / does [he / she]] have any difficulty...)

Getting in or out of bed or a chair?

1. Yes 5. No → GO TO H9E



H10D1. [CYNAMF CYNAML]: [CYAQRTH], [CYFUHU], Age [AGEIWDATE]

Does someone usually help [you / him / her] with that activity?

1. Yes 5. No

H10D2. [CYNAMF CYNAML]: [CYAQRTH], [CYFUHU], Age [AGEIWDATE]

[Do you / Does [he / she]] usually use special equipment to do that activity?

1. Yes 5. No

H9E. [CYNAMF CYNAML]: [CYAQRTH], [CYFUHU], Age [AGEIWDATE]

Because of a health or physical problem, [do you / does [RP / SP]] have any difficulty...)
Walking?

1. Yes 5. No → GO TO H9F



H10E1. [CYNAMF CYNAML]: [CYAQRTH], [CYFUHU], Age [AGEIWDATE]

Does someone usually help [you / him / her] with that activity?

1. Yes 5. No

H10E2. [CYNAMF CYNAML]: [CYAQRTH], [CYFUHU], Age [AGEIWDATE]

[Do you / Does [he / she]] usually use special equipment to do that activity?

1. Yes 5. No

H9F. [CYNAMF CYNAML]: [CYAQRTH], [CYFUHU], Age [AGEIWDATE]

(Because of a health or physical problem, [do you / does [he / she]] have any difficulty...)
Getting outside?

1. Yes 5. No → GO TO H9G



H10F1. [CYNAMF CYNAML]: [CYAQRTH], [CYFUHU], Age [AGEIWDATE]

Does someone usually help [you / him / her] with that activity?

1. Yes 5. No

H10F2. [CYNAMF CYNAML]: [CYAQRTH], [CYFUHU], Age [AGEIWDATE]

[Do you / Does [he / she]] usually use special equipment to do that activity?

1. Yes 5. No

H9G. [CYNAMF CYNAML]: [CYAQRTH], [CYFUHU], Age [AGEIWDATE]

(Because of a health or physical problem, [do you / does [he / she]] have any difficulty...)
Using the toilet, including getting to the toilet?

1. Yes 5. No → GO TO H11A



H10G1. [CYNAMF CYNAML]: [CYAQRTH], [CYFUHU], Age [AGEIWDATE]

Does someone usually help [you / him / her] with that activity?

1. Yes 5. No

H10G2. [CYNAMF CYNAML]: [CYAQRTH], [CYFUHU], Age [AGEIWDATE]

[Do you / Does [he / she]] usually use special equipment to do that activity?

1. Yes 5. No

Instrumental Activities of Daily Living (IADL) - Reference Person and Spouse/Partner

H11A. [CYNAMF CYNAML]: [CYAQRTH], [CYFUHU], Age [AGEIWDATE]

The next questions are about doing other activities by [yourself / himself / herself] and without special equipment. Because of a health or physical problem, [do you / does [RP / SP]] have any difficulty preparing [your / his / her] own meals?

1. Yes 5. No DK/RF 7. Does not do → H11B. [CYNAMF CYNAML]: [CYAQRTH], [CYFUHU], Age [AGEIWDATE]
 Is this because of a health or physical problem?

1. Yes 5. No

H11C. [CYNAMF CYNAML]: [CYAQRTH], [CYFUHU], Age [AGEIWDATE]

((Do you / Does [RP / SP]) have any difficulty...)
Shopping for personal items or medicines?

1. Yes 5. No DK/RF 7. Does not do → H11D. [CYNAMF CYNAML]: [CYAQRTH], [CYFUHU], Age [AGEIWDATE]
 Is this because of a health or physical problem?

1. Yes 5. No

H11E. [CYNAMF CYNAML]: [CYAQRTH], [CYFUHU], Age [AGEIWDATE]

((Do you / Does [RP / SP]) have any difficulty...)

Managing [your / his / her] own money, such as keeping track of expenses or paying bills?

1. Yes 5. No DK/RF 7. Does not do → H11F. [CYNAMF CYNAML]: [CYAQRTH], [CYFUHU], Age [AGEIWDATE]
 Is this because of a health or physical problem?

1. Yes 5. No

H11G. [CYNAMF CYNAML]: [CYAQRTH], [CYFUHU], Age [AGEIWDATE]

((Do you / Does [RP / SP]) have any difficulty...)

Using the telephone?

1. Yes 5. No DK/RF 7. Does not do → H11H. [CYNAMF CYNAML]: [CYAQRTH], [CYFUHU], Age [AGEIWDATE]
 Is this because of a health or physical problem?

1. Yes 5. No

H11J. [CYNAMF CYNAML]: [CYAQRTH], [CYFUHU], Age [AGEIWDATE]

((Do you / Does [RP / SP]) have any difficulty...)

Doing heavy housework, like scrubbing floors or washing windows?

1. Yes 5. No DK/RF 7. Does not do → H11K. [CYNAMF CYNAML]: [CYAQRTH], [CYFUHU], Age [AGEIWDATE]
 Is this because of a health or physical problem?

1. Yes 5. No

H11L. [CYNAMF CYNAML]: [CYAQRTH], [CYFUHU], Age [AGEIWDATE]

((Do you / Does [RP / SP]) have any difficulty...)

Doing light housework, like doing dishes, straightening up, or light housecleaning?

1. Yes 5. No DK/RF 7. Does not do → H11M. [CYNAMF CYNAML]: [CYAQRTH], [CYFUHU], Age [AGEIWDATE]
 Is this because of a health or physical problem?

1. Yes 5. No

Leisure and Exercise - Reference Person and Spouse/Partner

H12A. [CYNAMF CYNAML]: [CYAQRTH], [CYFUHU], Age [AGEIWDATE]

The next questions are about physical activities (exercise, sports, physically active hobbies...) that [you / [RP / SP]] may do in [your / his / her] leisure time.

(In [your / [RP / SP]'s] leisure time,) how often [do you / does [RP / SP]] do VIGOROUS activities for at least 10 minutes that cause heavy sweating or large increases in breathing or heart rate?

- ENTER amount here, then SELECT unit of time on next screen (Week, Month, Year)
- If R says never, ENTER [0]
- If R says every day, ENTER [7] here and ENTER [WEEK] on the next screen
- If R reports hours or minutes per week/month/year, PROBE: We are looking for the number of times per week, month, or year

→ GO TO H12B → GO TO H12B



H12APER. The amount entered is: [H12A] times per ____

- SELECT the unit of time below
- If R says every day, ENTER [7] on the previous screen and ENTER [WEEK] here

H12B. [CYNAMF CYNAML]: [CYAQRTH], [CYFUHU], Age [AGEIWDATE]

(In [your / [RP / SP]'s] leisure time,...)

(How often [do you / does [RP / SP]] do) light or moderate activities for at least 10 minutes that cause only light sweating or slight to moderate increases in breathing or heart rate?

- ENTER amount here, then SELECT unit of time on next screen (Week, Month, Year)
- If R says never, ENTER [0]
- If R says every day, ENTER [7] here and ENTER [WEEK] on the next screen
- If R reports hours or minutes per week/month/year, PROBE: We are looking for the number of times per week, month, or year

→ GO TO H12C → GO TO H12C



H12BPER. The amount entered is: [H12B] times per ____

- SELECT the unit of time below
- If R says every day, ENTER [7] on the previous screen and ENTER [WEEK] here

H12C. [CYNAMF CYNAML]: [CYAQRTH], [CYFUHU], Age [AGEIWDATE]

(In [your / [RP / SP]'s] leisure time,...)

(How often [do you / does [RP / SP]] do) physical activities specifically designed to strengthen [your / his / her] muscles such as lifting weights?

- ENTER amount here, then SELECT unit of time on next screen (Week, Month, Year)
- If R says never, ENTER [0]
- If R says every day, ENTER [7] here and ENTER [WEEK] on the next screen
- If R reports hours or minutes per week/month/year, PROBE: We are looking for the number of times per week, month, or year

→ GO TO H13 → GO TO H13



H12CPER. The amount entered is: [H12C] times per ____

- SELECT the unit of time below
- If R says every day, ENTER [7] on the previous screen and ENTER [WEEK] here

3. Week 5. Month 6. Year 7. Other-specify (H12CPERSPEC. Specify. (String 100))

Smoking - Reference Person and Spouse/Partner

H13. [CYNAMF CYNAML]: [CYAQRTH], [CYFUHU], Age [AGEIWDATE]

[Do you / Does [RP / SP]] smoke cigarettes?

1. Yes 5. No → GO TO H16CKPT



H14. [CYNAMF CYNAML]: [CYAQRTH], [CYFUHU], Age [AGEIWDATE]

On average, how many cigarettes per day [do you / does [he / she]] usually smoke?

- DEFINITION: A standard pack of American cigarettes contains 20 cigarettes
- For one cigarette or less per day, ENTER [1]

1 – 200

H15CKPT. CAI Checkpoint: Type of Interview; Whether Current Smoker Reported Smoking Last Wave

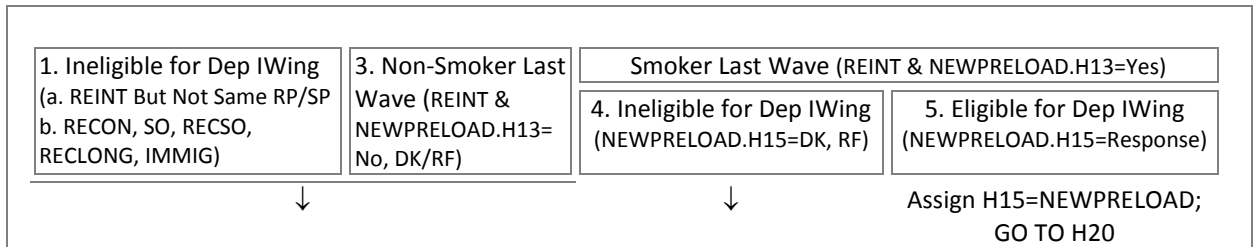

Dependent Interviewing for Reinterviews

H15. [CYNAMF CYNAML]: [CYAQRTH], [CYFUHU], Age [AGEIWDATE]

How old [were you / was [RP / SP]] when [you / he / she] first smoked cigarettes regularly?

1 – [CURRENT AGE] → GO TO H20

H16CKPT. CAI Checkpoint: Type of Interview; Whether Current Non-Smoker Reported Smoking Last Wave

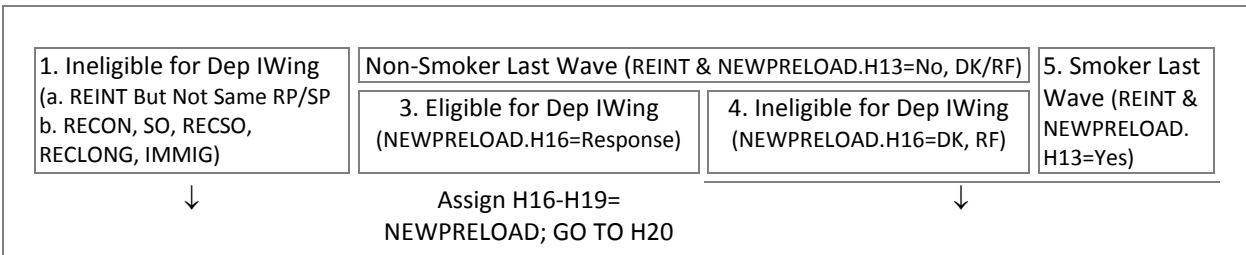

Dependent Interviewing for Reinterviews

H16. [CYNAMF CYNAML]: [CYAQRTH], [CYFUHU], Age [AGEIWDATE]

Did [you / [RP / SP]] ever smoke cigarettes?

1. Yes 5. No → GO TO H20



Dependent Interviewing for Reinterviews

H17. [CYNAMF CYNAML]: [CYAQRTH], [CYFUHU], Age [AGEIWDATE]

On average, how many cigarettes per day did [you / he / she] smoke?

- DEFINITION: A standard pack of American cigarettes contains 20 cigarettes
- For one cigarette or less per day, ENTER [1]

1 – 200

Dependent Interviewing for Reinterviews

H18. [CYNAMF CYNAML]: [CYAQRTH], [CYFUHU], Age [AGEIWDATE]

How old [were you / was [RP / SP]] when [you / he / she] last smoked cigarettes regularly?

1 – [CURRENT AGE]

Dependent Interviewing for Reinterviews

H19. [CYNAMF CYNAML]: [CYAQRTH], [CYFUHU], Age [AGEIWDATE]

How old [were you / was [RP / SP]] when [you / he / she] first smoked cigarettes regularly?

1 – [CURRENT AGE (H18)]

Alcohol Use - Reference Person and Spouse/Partner

H20. [CYNAMF CYNAML]: [CYAQRTH], [CYFUHU], Age [AGEIWDATE]

[Do you / Does [RP / SP]] ever drink any alcoholic beverages such as beer, wine, or liquor?

1. Yes 5. No → GO TO H22

↓

H21A. [CYNAMF CYNAML]: [CYAQRTH], [CYFUHU], Age [AGEIWDATE]

In the last year, on average, how often did [you / [RP / SP]] have any alcohol to drink? Would you say: less than once a month, about once a month, several times a month, about once a week, several times a week, or every day?

- If R says "Did not drink in the last year", ENTER [1]

1. Less than once a month

2. About once a month

3. Several times a month

4. About once a week

5. Several times a week

6. Every day

DK/RF

→ GO TO H22

↓

H21B. [CYNAMF CYNAML]: [CYAQRTH], [CYFUHU], Age [AGEIWDATE]

In the last year, on the days [you / he / she] drank, about how many drinks did [you / he / she] have?

- If R says "Did not drink in the last year", ENTER [0]

0 – 25

H21C. [CYNAMF CYNAML]: [CYAQRTH], [CYFUHU], Age [AGEIWDATE]

In the last year, on how many days [have you / has [he / She]] had [MALE: five / FEMALE: four] or more drinks on one occasion?

- ENTER [0] for None

0 – 365

Weight and Height - Reference Person and Spouse/Partner

H22. [CYNAMF CYNAML]: [CYAQRTH], [CYFUHU], Age [AGEIWDAT]

About how much [do you / does [RP / SP]] weigh?

- ENTER weight in pounds or PRESS [Enter] to continue to next screen for kilograms
- If more than 400 pounds, ENTER [400]

[ENTER] 50 – 400 DK/RF
↓
GO TO H23FT

H22KILO. [CYNAMF CYNAML]: [CYAQRTH], [CYFUHU], Age [AGEIWDAT]

(About how much [do you / does [RP / SP]] weigh?)

- ENTER weight in kilograms
- If more than 180 kilograms, ENTER [180]

36.0 – 180.0

H23FT. [CYNAMF CYNAML]: [CYAQRTH], [CYFUHU], Age [AGEIWDAT]

How tall [are you / is [RP / SP]]?

- ENTER height in feet and inches or PRESS [Enter] to continue to next screen for meters

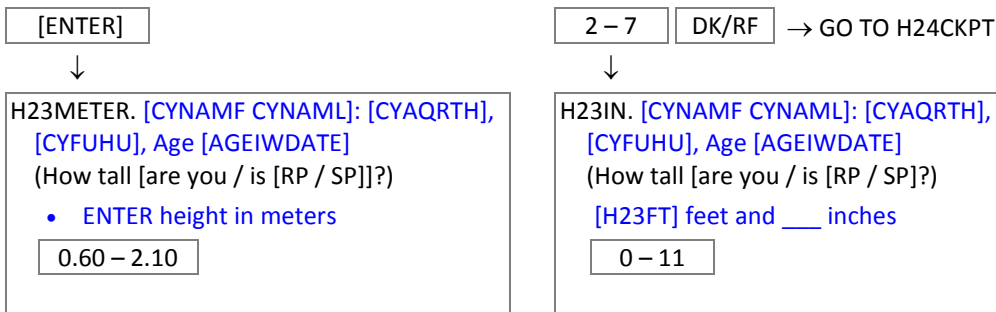

END H1_H23

H24CKPT. CAI Checkpoint: Whether Spouse/Partner in FU

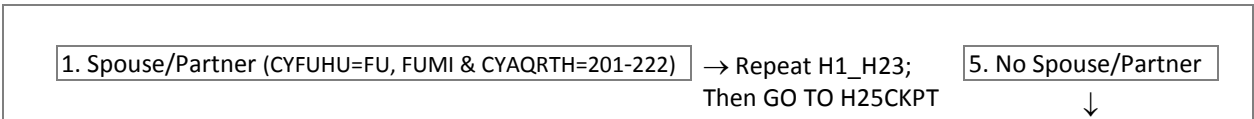

Childhood Health - Respondent and Spouse/Partner

H25CKPT[1-2]. CAI Checkpoint: Who is Respondent; Whether Childhood Report Needed ([1]=R, [2]=R's spouse or partner)

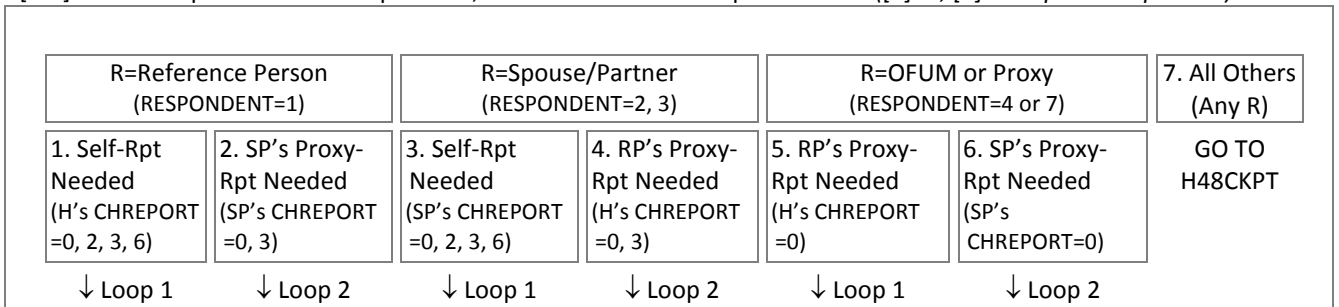

SECTION_H.H25_H45 [1-2] [1]=R (or RP if R=OFUM, Proxy), [2]=R's spouse or partner (or SP if R=OFUM, Proxy)

HEALTHAQS. AQS. of Current Reference Person (Spouse/Partner)

REPORTAQS. AQS. of Respondent

H25_INTRO. [CYNAMF CYNAML]: [CYAQRTH], [CYFUHU], Age [AGEIWDTE]

These next questions ask about [your / [RP / SP]'s] health during childhood, that is, before age 17. [R=OFUM, PROXY: I understand that it may be difficult for you to answer these questions, but please do your best.]

- ENTER [1] to continue

H25. [CYNAMF CYNAML]: [CYAQRTH], [CYFUHU], Age [AGEIWDTE]

Consider [your / [RP / SP]'s] health while [you were / [he / she] was] growing up, before [you were / [he / she] was] 17 years old. Would you say that [your / his / her] health during that time was excellent, very good, good, fair or poor?

H26. (H1D) [CYNAMF CYNAML]: [CYAQRTH], [CYFUHU], Age [AGEIWDTE]

When [you were / [he / she] was] growing up, before [you were / [he / she] was] 17 years old, did [you / he / she] miss a month or more of school because of a health problem?

H27. [CYNAMF CYNAML]: [CYAQRTH], [CYFUHU], Age [AGEIWDTE]

Before [you were / [he / she] was] 17 years old, did [you / he / she] have any of the following childhood diseases: Measles?

H28. [CYNAMF CYNAML]: [CYAQRTH], [CYFUHU], Age [AGEIWDTE]

(Before [you were / [he / she] was] 17 years old, did [you / he / she] have...) Mumps?

H29. [CYNAMF CYNAML]: [CYAQRTH], [CYFUHU], Age [AGEIWDTE]

(Before [you were / [he / she] was] 17 years old, did [you / he / she] have...) Chicken pox?

H30. [CYNAMF CYNAML]: [CYAQRTH], [CYFUHU], Age [AGEIWDTE]

(Before [you were / [he / she] was] 17 years old, did [you / he / she] have...) Difficulty seeing, even with eye glasses or prescription lenses?

H31. [CYNAMF CYNAML]: [CYAQRTH], [CYFUHU], Age [AGEIWDTE]

Did one or both of [your / his / her] parents or guardians smoke during [your / his / her] childhood? **If Yes:** Was that one or both of them?

H32. [CYNAMF CYNAML]: [CYAQRTH], [CYFUHU], Age [AGEIWDATE]

Before [you were / [he / she] was] 17 years old, did [you / he / she] have any of the following childhood diseases:
Asthma?

1. Yes 5. No

H33. [CYNAMF CYNAML]: [CYAQRTH], [CYFUHU], Age [AGEIWDATE]

(Before [you were / [he / she] was] 17 years old, did [you / he / she] have...)
Diabetes?

1. Yes 5. No

H34. [CYNAMF CYNAML]: [CYAQRTH], [CYFUHU], Age [AGEIWDATE]

(Before [you were / [he / she] was] 17 years old, did [you / he / she] have...)
A respiratory disorder such as bronchitis, wheezing, hay fever, shortness of breath, or sinus infection?

1. Yes 5. No

H35. [CYNAMF CYNAML]: [CYAQRTH], [CYFUHU], Age [AGEIWDATE]

(Before [you were / [he / she] was] 17 years old, did [you / he / she] have...)
A speech impairment?

1. Yes 5. No

H36. [CYNAMF CYNAML]: [CYAQRTH], [CYFUHU], Age [AGEIWDATE]

(Before [you were / [he / she] was] 17 years old, did [you / he / she] have...)
An allergic condition?

1. Yes 5. No

H37. [CYNAMF CYNAML]: [CYAQRTH], [CYFUHU], Age [AGEIWDATE]

(Before [you were / [he / she] was] 17 years old, did [you / he / she] have...)
Heart trouble?

1. Yes 5. No

H38. [CYNAMF CYNAML]: [CYAQRTH], [CYFUHU], Age [AGEIWDATE]

(Before [you were / [he / she] was] 17 years old, did [you / he / she] have...)
Chronic ear problems or infections?

1. Yes 5. No

H39. [CYNAMF CYNAML]: [CYAQRTH], [CYFUHU], Age [AGEIWDATE]

Before [you were / [he / she] was] 17 years old, did [you / he / she] have any of the following childhood diseases:
Epilepsy or seizures?

1. Yes 5. No

H40. [CYNAMF CYNAML]: [CYAQRTH], [CYFUHU], Age [AGEIWDATE]

(Before [you were / [he / she] was] 17 years old, did [you / he / she] have...)
Severe headaches or migraines?

1. Yes 5. No

H41. [CYNAMF CYNAML]: [CYAQRTH], [CYFUHU], Age [AGEIWDATE]
 (Before [you were / [he / she] was] 17 years old, did [you / he / she] have...)
 Stomach problems?

1. Yes 5. No

H42. [CYNAMF CYNAML]: [CYAQRTH], [CYFUHU], Age [AGEIWDATE]
 (Before [you were / [he / she] was] 17 years old, did [you / he / she] have...)
 High blood pressure?

1. Yes 5. No

H43. [CYNAMF CYNAML]: [CYAQRTH], [CYFUHU], Age [AGEIWDATE]
 (Before [you were / [he / she] was] 17 years old, did [you / he / she] have...)
 Depression?

1. Yes 5. No

H44. [CYNAMF CYNAML]: [CYAQRTH], [CYFUHU], Age [AGEIWDATE]
 (Before [you were / [he / she] was] 17 years old, did [you / he / she] have...)
 Drug or alcohol problems?

1. Yes 5. No

H45. [CYNAMF CYNAML]: [CYAQRTH], [CYFUHU], Age [AGEIWDATE]
 (Before [you were / [he / she] was] 17 years old, did [you / he / she] have...)
 Any other emotional or psychological problems?

1. Yes 5. No

H46 Rule: Whether Any Health Conditions Endorsed

<table border="1"> <tr> <td>At Least One Condition H32-H45=Yes</td> <td>All Others</td> <td>→ GO TO CH END Rule</td> </tr> </table> <p style="text-align: center;">↓</p>	At Least One Condition H32-H45=Yes	All Others	→ GO TO CH END Rule
At Least One Condition H32-H45=Yes	All Others	→ GO TO CH END Rule	

Childhood Health EHC

SECTION_H.H25_H45 [1-2].EHC [1]=R (or RP if R=OFUM, Proxy), [2]=R's spouse or partner (or SP if R=OFUM, Proxy)

CALAQSN. AQSN of Current Reference Person (Spouse/Partner)

CAL_INTRO. [CYNAMF CYNAML]: [CYAQRTH], [CYFUHU], Age [AGEIWDATE]

We would like to know more about how old [you were / [RP / SP] was] when [you / he / she] had the health condition(s) we just talked about, but first I want to ask you about some other things that may have happened in [your / his / her] childhood.

- ENTER [1] to continue

1. Continue

Person: [CYNAMF CYNAML], CYAQRTH], Age: [AGEIWDATE], DOB: [CYMOBRN/CYDYBRN/CYRBRN]

If [your / [RP / SP]'s] parents or guardians separated during [your / his / her] childhood, please tell me how old [you were / [he / she] was] at the time of each separation, starting with the first time they separated. Any other separations?

If [you / [RP / SP]] moved during [your / his / her] childhood, please tell me how old [you were / [he / she] was] at the time of each move, starting with the first move. Any other moves?

At what age did [you / [RP / SP]] first start going to school? If [you / he / she] changed schools during [your / his / her] childhood, please tell me how old [you were / [he / she] was] each time, starting with the first time. Any other school changes?

At what age did [you / [RP / SP]] first have [HEALTH CONDITION*]? Until what age did [you / he / she] have it?

- PROBE for all ages 0-16 at which condition occurred
- IF R SAYS "Did not have that condition", CLICK any cell - SELECT Denial - then ENTER NOTE
- PROBE: If you don't know the exact age, please give us your best guess
- PROBE for age using landmarks, starting with the earliest landmark

For age at which condition ended:

- IF R SAYS "Older than 16", CLICK 17+ - SELECT Yes - ENTER Age
- IF R SAYS "Still have it", CLICK 17+ - SELECT Yes - SELECT Still Have It

Age	0	1	2	3	4	5	6	7	8	9	10	11	12	13	14	15	16		
Parental Separations																		[LANDMARK]EHC[0-16]	
Residential Moves																		0. Cancel	
School Changes																		1. Yes	
Age	0	1	2	3	4	5	6	7	8	9	10	11	12	13	14	15	16	17+	
Asthma																			[CONDITION]EHC[0-17]
Diabetes																			
Respiratory Disorder																			
Speech Impairment																		0. Cancel	
Allergic Condition																		1. Yes	
Heart Trouble																		7. Denial	
Ear Problems																		8. DK; DK All	
Epilepsy/Seizures																		8,1. DK Start	
Headaches/Migraines																		1,8. DK End	
Stomach Problems																		9. Refused	
High Blood Pressure																		[CONDITION]EHCAGEGR17	
Depression																		Enter Age 17-[AGE]	
Drug/Alcohol Problems																		Still have it ([AGE])	
Other Emotional/Psych																			

***HEALTH CONDITION**

H32=Yes: asthma

H33=Yes: diabetes

H34=Yes: a respiratory disorder such as bronchitis, wheezing, hay fever, shortness of breath, or sinus infection

H35=Yes: a speech impairment

H36=Yes: an allergic condition

H37=Yes: heart trouble

H38=Yes: chronic ear problems or infections

H39=Yes: epilepsy or seizures

H40=Yes: severe headaches or migraines

H41=Yes: stomach problems

H42=Yes: high blood pressure

H43=Yes: depression

H44=Yes: drug or alcohol problems

H45=Yes: any other emotional or psychological problems

CH END Rule: Whether SP in FU

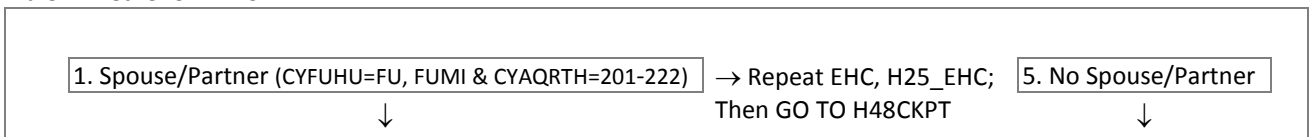

END EHC

END H25_H45

Poor Health - OFUMs

H48CKPT. CAI Checkpoint: Whether There are OFUMs in the FU

1. OFUMs (CYFUHU=FU, FUMI & CYAQRTH>222)	5. No OFUMs	→ GO TO H50ACKPT
↓		

H49. Now about the rest of your family living there — are any family members in poor health?

1. Yes 5. No → GO TO H50ACKPT

↓

H50. Who is that?

- ENTER all that apply
- PROBE: Any others?

1 – 24. [CYNAMF CYNAML], [CYAQRTH], [CYFUHU] *AQSN list of OFUMs if FU, FUMI*

Dementia Screener – OFUMs and Non-Current RP and S/P Age 65 or Older

H50B-H50I: All rights reserved. Copyright 2008 by Washington University in St. Louis, Missouri.

H50ACKPT[1-24]. CAI Checkpoint: Whether FU Member is OFUM Age 65+ and CYFUHU=FU, MO, INST-HLTH, INST-OTH, or RP/SP Age 65+ and CYFUHU=MO, INST-HLTH, INST-OTH ([1-24]=AQSN of FU Member)

1. OFUM Age 65+ (AGEIWDATE=65+; CYFUHU=FU, FUMI, MO, HLTH, OTH INST; CYAQRTH>222)	3. RP/SP Age 65+ (AGEIWDATE=65+; CYFUHU=MO, HLTH, OTH INST; CYAQRTH=101-222)	5. All Others	→ GO TO H58 RULE
↓			

SECTION_H.H50A_H50I [1-24] [1-24]=AQSN of FU Member

AQSN. AQSN of FU Member

H50B. [CYNAMF CYNAML]: [CYAQRTH], [CYFUHU], Age [AGEIWDATE]

Next, we'd like to know about changes that [you / [CYNAMF CYNAML]] may have had in the last several years [*R IS NOT THIS FU MEMBER: because of a thinking or memory problem*].

In the last several years, has there been a change in problems [you / he / she] may have with judgment, for example, problems making decisions, making bad financial decisions, or with thinking?

1. Yes, a change 5. No, no change

H50C. [CYNAMF CYNAML]: [CYAQRTH], [CYFUHU], Age [AGEIWDATE]

In the last several years, has there been a change in...

The amount of interest [you / he / she] may have in hobbies or activities?

1. Yes, a change 5. No, no change

H50D. [CYNAMF CYNAML]: [CYAQRTH], [CYFUHU], Age [AGEIWDATE]

(In the last several years, has there been a change in...)

[Your / His / Her] repeating the same things over and over, such as questions, stories, or statements?

1. Yes, a change 5. No, no change

H50E. [CYNAMF CYNAML]: [CYAQRTH], [CYFUHU], Age [AGEIWDATE]

(In the last several years, has there been a change in ...)

The trouble [you / he / she] may have learning how to use a tool, appliance or gadget like a TV remote?

1. Yes, a change 5. No, no change

H50F. [CYNAMF CYNAML]: [CYAQRTH], [CYFUHU], Age [AGEIWDATE]

(In the last several years, has there been a change in ...)

[Your / His / Her] forgetting the correct month or year?

1. Yes, a change 5. No, no change

H50G. [CYNAMF CYNAML]: [CYAQRTH], [CYFUHU], Age [AGEIWDATE]

(In the last several years, has there been a change in...)

The trouble [you / he / she] may have handling complicated money matters, like balancing a checkbook or paying bills?

1. Yes, a change 5. No, no change

H50H. [CYNAMF CYNAML]: [CYAQRTH], [CYFUHU], Age [AGEIWDATE]

(In the last several years, has there been a change in...)

The trouble [you / he / she] may have remembering appointments?

1. Yes, a change 5. No, no change

H50I. [CYNAMF CYNAML]: [CYAQRTH], [CYFUHU], Age [AGEIWDATE]

(In the last several years, has there been a change in...)

Daily problems [you / he / she] may have with thinking and/or memory?

1. Yes, a change 5. No, no change

END H50A_H50I

H50J Rule: Whether More Eligible 65+ Year Olds

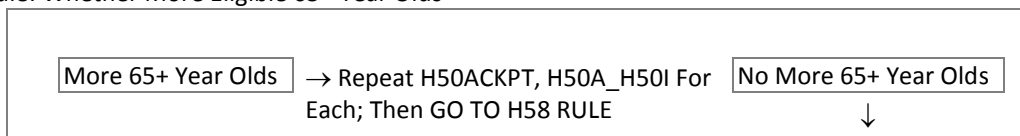

Mental Health Screener - Respondent

H58 Rule: Who is Respondent

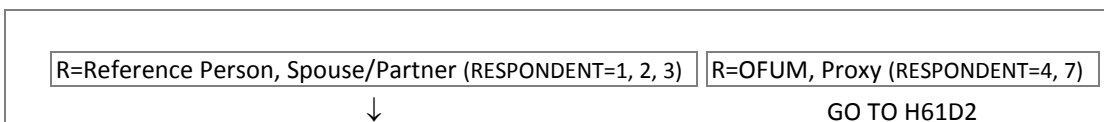

H59A. Now, I am going to ask you (Respondent: [CYNAMF CYNAML]) some questions about feelings you may have had over the PAST 30 days. Please answer using one of the following choices: All of the time, most of the time, some of the time, a little of the time, none of the time.

In the past 30 days, about how often did you feel...

So sad nothing could cheer you up?

1. All of the time 2. Most of the time 3. Some of the time 4. A little of the time 5. None of the time

H59B. (In the past 30 days, about how often did you feel...)

Nervous?

(Would you say all of the time, most of the time, some of the time, a little of the time, or none of the time?)

1. All of the time 2. Most of the time 3. Some of the time 4. A little of the time 5. None of the time

H59C. (In the past 30 days, about how often did you feel...)

Restless or fidgety?

(Would you say all of the time, most of the time, some of the time, a little of the time, or none of the time?)

1. All of the time 2. Most of the time 3. Some of the time 4. A little of the time 5. None of the time

H59D. (In the past 30 days, about how often did you feel...)

Hopeless?

(Would you say all of the time, most of the time, some of the time, a little of the time, or none of the time?)

1. All of the time 2. Most of the time 3. Some of the time 4. A little of the time 5. None of the time

H59E. (In the past 30 days, about how often did you feel...)

That everything was an effort?

(Would you say all of the time, most of the time, some of the time, a little of the time, or none of the time?)

1. All of the time 2. Most of the time 3. Some of the time 4. A little of the time 5. None of the time

H59F. (In the past 30 days, about how often did you feel...)

Worthless?

(Would you say all of the time, most of the time, some of the time, a little of the time, or none of the time?)

1. All of the time 2. Most of the time 3. Some of the time 4. A little of the time 5. None of the time

H59G Rule: Whether One or More H59A-H59F Endorsed As All/Most/Some

One or More H59A-H59F = All/Most/Some All Others → GO H61D2



H59J. How much do these feelings usually interfere with your life or activities - a lot, some, a little, or not at all?

1. A lot 2. Some 3. A little 5. Not at all

Current Health Insurance

H61D2. Next, please think about your [family's] health insurance, including coverage obtained through employment, or purchased directly, or through a government program like Medicare and Medicaid.

[Do you / Does anyone in your family] currently have health insurance or health care coverage?

1. Yes 5. No → GO TO H61K



H61D3 Rule: Number of FU Members

More Than One FU Member Only One FU Member → Assign H61D3 & H61DAQSN =AQSN of FU Member; Then GO TO H61E RULE



H61D3. Who is covered (by health insurance)?

- ENTER all that apply
- PROBE: Any others?

1 – 24. [CYNAMF CYNAML], [CYAQRTH], [CYFUHU] DK/RF → GO TO H61K
AQSN list of FU Members if FU, FUMI



H61D4CKPT. Number of FU Members Selected at H61D3

1. One FU Member → GO TO H61E RULE 5. More Than One FU Member
 ↓

H61D4. Does everyone have the same health insurance or health care coverage?

[FU Members With Health Care Coverage/Insurance:](#)
[\[List of H61D3 Selections\]](#)

1. Yes → GO TO H61E 5. No



H61E Rule: Whether FU Member Selected at H61D3

Selected at H61D3 Not Selected → Repeat H61E Rule For Next FU Member;
 Then GO TO H61K
 ↓

SECTION_H.H61E_H61G [1-24] [1-24]=AQSN of FU Member

H61DAQSN. AQSN of FU Member

H61E. [H61D4<>YES: [CYNAMF CYNAML], [CYAQRTH], [CYFUHU]]

[1st ITERATION: What is the source of [H61D4=YES: that coverage? / ALL OTHERS: [your / [CYNAMF]'s health insurance or health care coverage -- is it provided through an employer, privately purchased, a government program like Medicare or Medicaid, or what]? / ALL OTHERS: What about the source of [your / CYNAMF]'s coverage (is it provided through an employer, privately purchased, a government program like Medicare or Medicaid, or what)?]

- IF needed/IF R mentions the name of the provider: Is it provided through an employer, privately purchased, a government program like Medicare or Medicaid, or what?
- IF R mentions government plan: Is that Medicare, Medi-gap, Medicaid or a state program, military provided such as Tricare, ChampUS or ChampVA, Indian health insurance, or some other plan?
- IF needed (if Affordable Care Act/Obamacare/Health Insurance Exchanges mentioned): Was that a privately purchased health insurance plan or Medicaid/[STATEMEDPROG]/[SCHIPNAME]?
- ENTER all that apply
- PROBE: Any others?

1. Employer provided health insurance (Current or former employer)			
2. Private health insurance purchased	3. Medicare	4. Medi-Gap/Supplemental	
5. Medicaid/[STATEMEDPROG]/[SCHIPNAME]	6. Military Health Care/Tricare (Active duty)		
7. Tricare/Champus/ChampVA (Dependents, veterans)	8. Indian Health Insurance		
11. Veterans Administration (VA)	97. Other-specify		

SIGNAL for Medicare or Medicaid not selected at H61E:

IWER: READ QUESTION TO VERIFY MEDICARE AND/OR MEDICAID COVERAGE: How about [3 NOR 5 SELECTED: Medicare and Medicaid, [PYSTATERESIDE<>FC/DK/RF: [STATEMEDPROG], [SCHIPNAME]] / 3 SELECTED BUT NOT 5: Medicaid, [PYSTATERESIDE<>FC/DK/RF: [STATEMEDPROG], [SCHIPNAME]] / 5 SELECTED BUT NOT 3: Medicare]? ([H61D4=YES: Does your family / ALL OTHERS: [Do you / Does [CYNAMF]] have (this / any of these)?)
 IF Yes ENTER [Close] or [Goto] to make Medicare / Medicaid selection(s)
 IF No, Dk, Rf..... ENTER [Suppress] to go forward with interview

H61ESPEC Rule: H61E Selection

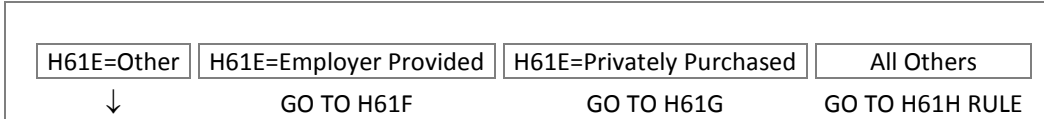

H61ESPEC. [H61D4<>YES: [CYNAMF CYNAML], [CYAQRTH], [CYFUHU]]

Could you tell me a little more about that other plan or program?

[Health Plan\(s\) Selected:](#)

[\[List of H61E Selections\]](#)

String 100

H61E2CKPT. If FU Members Have Different Insurance - Whether FU Member is 18 Years Old or Younger

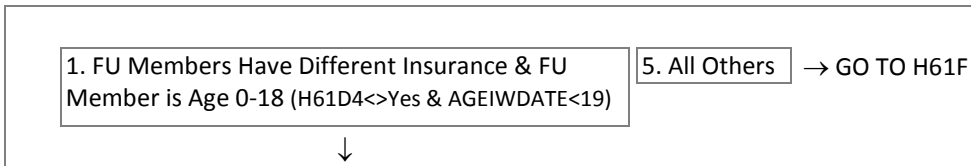

H61E2. [H61D4<>YES: [CYNAMF CYNAML], [CYAQRTH], [CYFUHU]]

Interviewer Checkpoint:

- Is that [STATE SCHIP PROGRAM NAME], the state health insurance plan for uninsured children?
- ENTER Yes or No; ASK R only if you are unclear about the answer

[Health Plan\(s\) Selected:](#)

[\[List of H61E Selections\]](#)

1. Yes 5. No

H61E=Employer Provided Health Insurance

H61F. [H61D4<>YES: [CYNAMF CYNAML], [CYAQRTH], [CYFUHU]]

Whose employer provides [H61D4=YES: this / ALL OTHERS: [your / CYNAMF's]] health insurance?

- ENTER all that apply, maximum of 3 selections
- PROBE: Any others?

[Health Plan\(s\) Selected:](#)

[\[List of H61E Selections\]](#)

1 – 24. [CYNAMF CYNAML], [CYAQRTH], [CYFUHU] *AQSN list of FU Members if FU, FUMI*

25. Parent of [FU MEMBER], outside of FU

97. Other person outside of FU-specify (H61FSPEC. Specify (String 100))

H61E= Private Health Insurance

H61G. [H61D4<>YES: [CYNAMF CYNAML], [CYAQRTH], [CYFUHU]]

Who is the policy holder on [this / [your / CYNAMF's]] private health insurance?

- **IF needed:** The policy holder is the person who purchased the insurance; other family members who are covered are called dependents.
- **ENTER all that apply, maximum of 3 selections**
- **PROBE:** Any others?

Health Plan(s) Selected:
[\[List of H61E Selections\]](#)

1 – 24. [CYNAMF CYNAML], [CYAQRTH], [CYFUHU] *AQSN list of FU Members if FU, FUMI*

25. Parent of [FU MEMBER], outside of FU

97. **Other person outside of FU-specify** (H61GSPEC. **Specify** (String 100))

END H61E_H61G

H61H Rule: If FU Members Have Different Insurance - Whether More FU Members Selected at H61D3

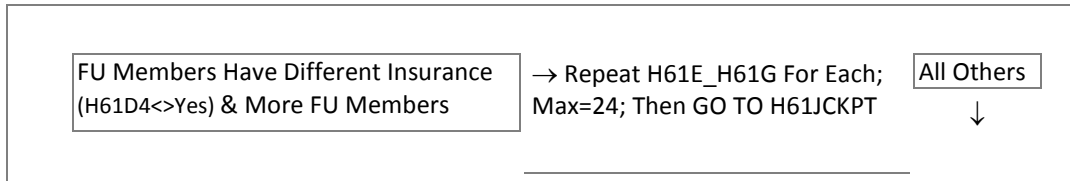

H61JCKPT. CAI Checkpoint: Whether Any FU Member Has Employer Provided or Privately Purchased Insurance

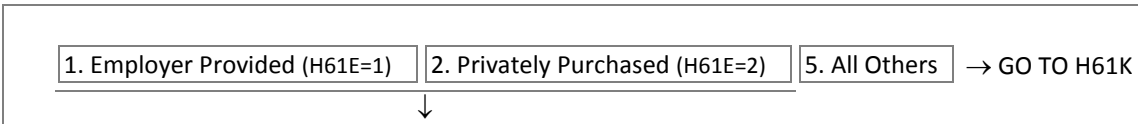

H61J. How much are your [and your family's] health insurance premiums [, altogether]? Please only include amounts that you [and your family] paid, either directly or through automatic deductions from pay. Do not include amounts paid by someone outside of your family.

- **ENTER amount here, then SELECT unit of time on next screen (Week, Two Weeks, Month, Year)**

\$ 0 → GO TO H61K \$ 1 – 99,997 DK/RF → GO TO H61JD



H61JPER. The amount entered is: [H61J] per ____

- **SELECT the unit of time below**

3. Week 4. Two weeks 5. Month 6. Year 7. **Other-specify** (H61JPERSPEC. **Specify**. (String 100))

GO TO H61K

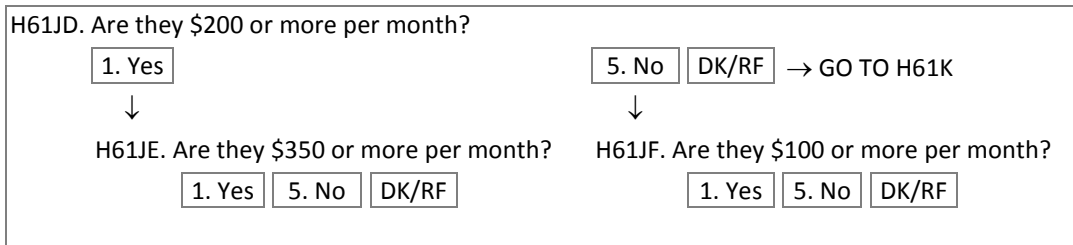

No Health Insurance PYear or P2Year

H61K. Did [you / [RP]] [or anyone else in the family living there] go without health insurance at any time during [P2YEAR] or [PYEAR]?

1. Yes 5. No → GO TO H62CKPT



H61L Rule: Number of FU Members

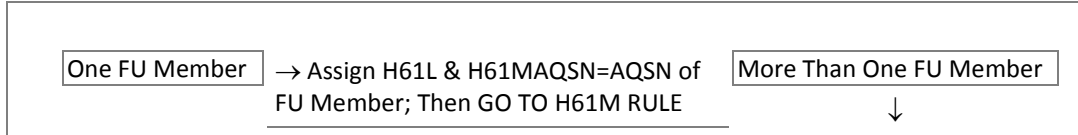

H61L. Who was that?

- ENTER all that apply
- PROBE: Any others?

1 – 24. [CYNAMF CYNAML], [CYAQRTH], [CYFUHU] DK/RF → GO TO H64

AQSN list of FU Members if FU, FUMI & Birth Year<CY



SECTION_H.H61M_H61N[1-24] [1-24]=AQSN of FU Member

H61M Rule: Whether FU Member Born in P2YEAR or Earlier

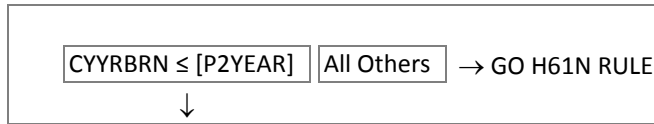

H61MAQSN. AQSN of FU Member

H61M. [CYNAMF CYNAML], [CYAQRTH], [CYFUHU]

For how many months in [P2YEAR] [were you / was [CYNAMF]] uninsured?

H61N Rule: Whether FU Member Born in PYEAR or Earlier

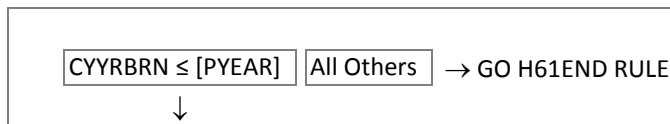

H61N. [CYNAMF CYNAML], [CYAQRTH], [CYFUHU]

(For how many months) in [PYEAR] ([were you / was [CYNAMF]] uninsured)?

END H61M_H61N

H61 END Rule: Whether More FU Members Selected at H61L

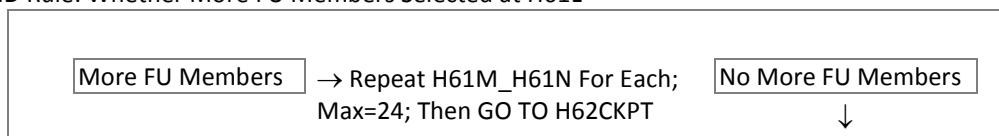

Medicare Linkage - Respondent

H62CKPT. CAI Checkpoint: Who is Respondent; Whether Medicare# Already Collected; Age; Has Medicare

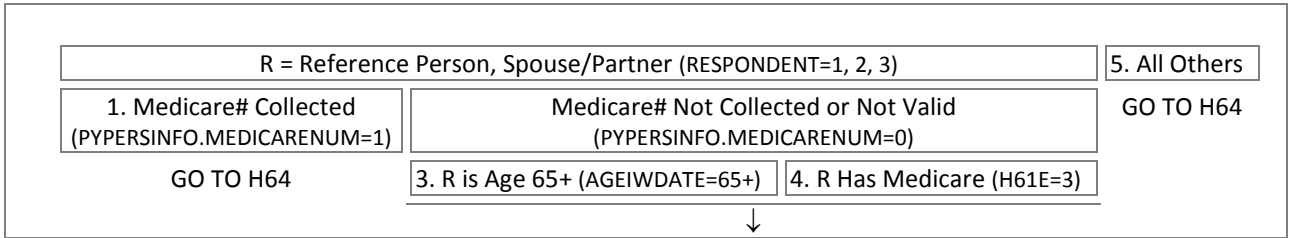

H62A. We would like to learn more about people’s health and how health care is used. The best place to get this information is Medicare. We are therefore asking F.E.S. (Family Economics Study) families to let us access these records. *[NO CHRONIC CONDITIONS ENDORSED (H5): Even if you don’t have any health conditions, it is important for statistical purposes to get this information from Medicare.]*

Under the Privacy Act of 1974, providing your number is a voluntary decision. The benefits you may be receiving under Medicare will not be affected in any way by your decision.
 Could you tell me your Medicare number for this purpose?

1. Yes 5. No → GO TO H64



H62A1. Medicare is mailing new cards on a rolling basis to everyone with Medicare. The new card includes a new Medicare number unique to you, instead of a Social Security-based number.
 Have you received a new card with your new 11-digit Medicare number?

1. Yes → GO TO H62G 5. No



H62B. Does your card include a Medicare Claim number or a Railroad Retirement Board Claim number?

- IF R says they have an 11-digit “Medicare Number”, GO BACK and ENTER [Yes] at the previous question

1. Medicare Claim Number 2. Railroad Retirement Board Claim Number DK/RF → GO TO H64



GO TO H62D

H62C. What is your complete Medicare Claim Number, including the letters or number at the end?

- ENTER the 9-digit number, then any letter(s) and number(s) at the end

____-____-____-____-____-____-____-____-____ → GO TO H64

H62D. Is that a 9-digit or 6-digit number?

1. 9-digit



H62E. What is your complete Railroad Retirement Claim Number, including the letter(s) at the beginning?

- ENTER up to 3 letter(s) at the beginning and then the 9-digit number
- If there are less than 3 letter(s), press the space bar to enter blank(s), then ENTER the letter(s)

____-____-____-____-____-____-____-____-____ GO TO H64

2. 6-digit DK/RF → GO TO H64



H62F. What is your complete Railroad Retirement Claim Number, including the letter(s) at the beginning?

- ENTER up to 3 letter(s) at the beginning and then the 6-digit number
- If there are less than 3 letter(s), press the space bar to enter blank(s), then ENTER the letter(s)

____-____-____-____-____-____-____-____-____ GO TO H64

H62G. What is your complete Medicare Number?

- ENTER the 11-digit number, including letter(s) and number(s)

_____ - _____ - _____

PYear Health Care Expenses

H64. These next questions are about health care expenditures that [you [and your family] / they] may have had during [PYEAR]. About how much did you [and your family] pay out-of-pocket for nursing home and hospital bills in [PYEAR]?

\$ 0 – 999,997 → GO TO H70

DK/RF



H65. Would it amount to \$1,000 or more?

1. Yes ↓ H66. \$2,000 or more?

5. No DK/RF ↓ H69. \$500 or more?

1. Yes 5. No DK/RF ↓ GO TO H70

1. Yes 5. No DK/RF ↓ GO TO H70

1. Yes 5. No DK/RF

H70. About how much did you [and your family] pay out-of-pocket for doctor, outpatient surgery, and dental bills in [PYEAR]?

\$ 0 – 999,997 → GO TO H76

DK/RF



H71. Would it amount to \$1,000 or more?

1. Yes ↓ H72. \$2,500 or more?

5. No DK/RF → GO TO H76 ↓ H74. \$500 or more?

1. Yes 5. No DK/RF ↓ GO TO H76

1. Yes 5. No DK/RF

H76. About how much did you [and your family] pay out-of-pocket for prescriptions, in-home medical care, special facilities, and other services in [PYEAR]?

\$ 0 – 999,997 → GO TO SECTION J

DK/RF



H77. Would it amount to \$500 or more?

1. Yes ↓ H78. \$2,500 or more?

5. No DK/RF → GO TO SECTION J ↓ H81. \$200 or more?

1. Yes 5. No DK/RF ↓ GO TO SECTION J

1. Yes 5. No DK/RF ↓ GO TO SECTION J

1. Yes 5. No DK/RF

END SECTION_H

Section J: Marriages and Children

[TOC](#)

J1CKPT[1-24]. Section J Qualifier ([1-24]=AQSN of FU Member)

GROUP 1 – IWTYPE=REINT, SPLITOFF					
Male Reference Person and Female Spouse Same Married Couple as Last Wave (CYAQRTH/PYAQRTH[1]=101; CYFUHU/PYFUHU[1]=FU) & (CYAQRTH/PYAQRTH[2]=202; CYFUHU/PYFUHU[2]=FU)					
1. TypeA Female Spouse 15-44 (AGEIWDAT[2] =15-44)		2. TypeANoJ Female Spouse 45+, DK/RF (AGEIWDAT[2] >44, DK/RF)			
AS A <u>COUPLE</u> , UPDATE OWN/ADPT KIDS (J28-AS8A)		NO SECTION J FOR THIS COUPLE			
GROUP 2 – IWTYPE=REINT, SPLITOFF					
Reference Person/Spouse/Partner Was Reference Person/Spouse/Partner Last Wave					
3. TypeB1 Male (CYAQRTH=101, 201, 221; PYAQRTH=101-222; CYFUHU/PYFUHU=FU)		4. TypeB2 Female 15-44 CYAQRTH=102, 202, 222; PYAQRTH=101-222; CYFUHU/PYFUHU=FU; AGEIWDAT=15-44)		5. TypeB3 Female 45+, DK/RF (CYAQRTH=102, 202, 222; PYAQRTH=101-222; CYFUHU/PYFUHU=FU; AGEIWDAT>44, DK/RF)	
UPDATE MARRIAGES (J2-J12YR) and UPDATE OWN/ADPT KIDS (J28-AS8A)				UPDATE MARRIAGES (J2-J12YR)	
GROUP 3 – IWTYPE=REINT, SPLITOFF					
RP/SP Was OFUM Last Wave; New RP/SP; RP/SP Was INST Last Wave (PYAQRTH>222; CYFUHU/PYFUHU=FU); or (PYAQRTH=NULL; CYFUHU=FUMI; PYFUHU=NULL); or (PYAQRTH=101-222; CYFUHU=FUMI; PYFUHU=INST)		New OFUM 15-44 (CYAQRTH>222; CYFUHU=FUMI; AGEIWDAT=15-44)	Returning OFUM 15-44 (CYAQRTH>222; CYFUHU=FU; AGEIWDAT=15-44)	Returning or New OFUM <15, 45+, DK/RF (CYAQRTH>222; CYFUHU=FU, FUMI; AGEIWDAT>44, or AGEIWDAT<15, DK/RF)	
6. TypeC1A Male (CYAQRTH=101, 201, 221)	7. TypeC1B Female (CYAQRTH=102, 202, 222)	9. TypeC1D ALL MARRS (J12A-J26YR) & ALL OWN KIDS (J30-OS70)	16. TypeC1E ALL MARRS (J12A-J26YR) & UPDATE OWN KIDS (J28-OS70)	10. TypeC1NoJ (>44)	95. AllOthersC1 (<15, DK/RF)
ALL MARRIAGES (J12A-J26YR) & ALL OWN/ADPT KIDS (J30-AS8A)		ALL MARRS (J12A-J26YR) & ALL OWN KIDS (J30-OS70)		NO SECTION J FOR THIS PERSON	
GROUP 4 – IWTYPE=RECON, RECSO, IMMIG, RECLONG					
Returning or New RP/SP (CYFUHU=FU, FUMI)		Returning or New OFUM (CYAQRTH>222; CYFUHU=FU, FUMI; AGEIWDAT>44 OR AGEIWDAT<15, DK/RF)			
11. TypeC2A Male (CYAQRTH=101, 201, 221)	12. TypeC2B Female (CYAQRTH=102, 202, 222)	14. TypeC2D (15-44)	15. TypeC2NoJ (>44)	96. AllOthersC2 (<15, DK/RF)	
ALL MARRIAGES (J12A-J26YR) & ALL OWN/ADPT KIDS (J30-AS8A)		ALL MARRS (J12A-J26YR) & ALL OWN KIDS (J30-OS70)		NO SECTION J FOR THIS PERSON	
GROUP 5 – ALL OTHERS, ALL INTERVIEWS (IWTYPE=REINT, SO, REC, RECSO, IMMIG, RECLONG) & (CYAQRTH=101-982; CYFUHU=MO, DIED, INST)					
97. All Others → NO SECTION J FOR THIS PERSON					

NOTE: J1CKPT[x] is assigned to each FU member where [x] is that person's AQSN, 1-24; regardless of AQSN, the first loop of Section J is always asked about the current Reference Person and the 2nd loop is always asked about the current Spouse/Partner if there is one in the FU.

SECTION_J [1-24] [1-24]=AQSN of FU Member

FIRST ITERATION OF SECTION J:

J1A. Now I have some questions about marriage and children.

- ENTER [1] to continue

1. Continue

J2. AQSN of FU Member

J3CKPT. CAI Checkpoint: Marital Status (Type B. J1CKPT=3, 4, 5)

1. Widowed (Marital=3)	2. Separated (Marital=5); or Married Partner (Marital=1)	3. Divorced (Marital=4)	4. Married Reference Person, Spouse, OFUM (Marital=1)	5. Never Married (Marital=2)
↓	GO TO J6MO	GO TO J5MO	GO TO J7MO	GO TO J27CKPT

Marital Status - Update

SECTION_J [1-24].J4_J12 [1-24]=AQSN of FU Member

J4MO. FU Member: [CYAQRTH], [CYNAMF CYNAML], Age: [AGEIWDATE] [(Respondent)]

In what month and year [were you / was [RP / SP]] widowed?

- SELECT Month and [Enter] to go to next screen for year
- IF NECESSARY: What would be your best estimate?
- IF NEEDED: I understand that it may be difficult for you to answer these questions, but please do your best.

1. January	2. February	3. March	4. April	5. May	6. June
7. July	8. August	9. September	10. October	11. November	12. December
21. Winter	22. Spring	23. Summer	24. Fall		

J4YR. FU Member: [CYAQRTH], [CYNAMF CYNAML], Age: [AGEIWDATE] [(Respondent)]

The month entered is: [J4MO]

- ENTER the year below
- 1901 – [CYEAR] Actual year
- 9996 [P2YEAR] – [CYEAR], DK which year
- 9997 Before [P2YEAR], DK exact year

1901 – [P3YEAR]	[P2YEAR] – [CYEAR]	9996. [P2YEAR] – [CYEAR], DK Which Year	9997. Before [P2YEAR], DK Exact Year	DK/RF
GO TO J27CKPT		GO TO J7MO	GO TO J27CKPT	

J5MO. FU Member: [CYAQRTH], [CYNAMF CYNAML], Age: [AGEIWDATE] [(Respondent)]

In what month and year did [your / [RP / SP]'s] (divorce/annulment) become final?

- SELECT Month and [Enter] to go to next screen for year
- IF NECESSARY: What would be your best estimate?
- IF NEEDED: I understand that it may be difficult for you to answer these questions, but please do your best.

1. January	2. February	3. March	4. April	5. May	6. June
7. July	8. August	9. September	10. October	11. November	12. December
21. Winter	22. Spring	23. Summer	24. Fall		

J5YR. FU Member: [CYAQRTH], [CYNAMF CYNAML], Age: [AGEIWDATE] [(Respondent)]

The month entered is: [J5MO]

- ENTER the year below

1901 – [CYEAR] Actual year

9996 [P2YEAR] – [CYEAR], DK which year

9997 Before [P2YEAR], DK exact year

1901 – [P3YEAR]	[P2YEAR] – [CYEAR]	9996. [P2YEAR] – [CYEAR], DK Which Year	9997. Before [P2YEAR], DK Exact Year	DK/RF
GO TO J27CKPT		↓	GO TO J27CKPT	

J6MO. FU Member: [CYAQRTH], [CYNAMF CYNAML], Age: [AGEIWDATE] [(Respondent)]

[MARRIED PARTNER: Earlier you reported that [R: you are / ALL OTHERS: [PARTNER] is] married.

In what month and year did [R: you and your spouse / ALL OTHERS: [RP / SP] and [his / her] spouse] stop living together?

- SELECT Month and [Enter] to go to next screen for year
- IF NECESSARY: What would be your best estimate?
- IF NEEDED: I understand that it may be difficult for you to answer these questions, but please do your best.

1. January	2. February	3. March	4. April	5. May	6. June
7. July	8. August	9. September	10. October	11. November	12. December
21. Winter	22. Spring	23. Summer	24. Fall		

J6YR. FU Member: [CYAQRTH], [CYNAMF CYNAML], Age: [AGEIWDATE] [(Respondent)]

The month entered is: [J6MO]

- ENTER the year below

1901 – [CYEAR] Actual year

9996 [P2YEAR] – [CYEAR], DK which year

9997 Before [P2YEAR], DK exact year

1901 – [P3YEAR]	[P2YEAR] – [CYEAR]	9996. [P2YEAR] – [CYEAR], DK Which Year	9997. Before [P2YEAR], DK Exact Year	DK/RF
GO TO J27CKPT		↓	GO TO J27CKPT	

J7MO. FU Member: [CYAQRTH], [CYNAMF CYNAML], Age: [AGEIWDATE] [(Respondent)]

LOOP 1 & NO SP IN FU: In what month and year did [R=RP: you / R=OFUM, PROXY: [RP]] last get married?

LOOP 1 & SP IN FU: In what month and year did [R=RP: you and your spouse (last) get married / R=SPOUSE: you and [RP] get married / R=PARTNER, OFUM, PROXY: [RP] and his spouse (last) get married]?

LOOP 2: Please tell me again, in what month and year did [R=RP & SPOUSE IN FU: you and your spouse get married / R=RP & PARTNER IN FU: [PARTNER] and her spouse (last) get married / R=SPOUSE: you and your spouse get married / R=PARTNER: you and your spouse (last) get married / R=OFUM, PROXY: [SPOUSE] and her spouse (last) get married]?

- SELECT Month and [Enter] to go to next screen for year
- IF NECESSARY: What would be your best estimate?

1. January	2. February	3. March	4. April	5. May	6. June
7. July	8. August	9. September	10. October	11. November	12. December
21. Winter	22. Spring	23. Summer	24. Fall		

J7YR. FU Member: [CYAQRTH], [CYNAMF CYNAML], Age: [AGEIWDATE] [(Respondent)]

The month entered is: [J7MO]

- ENTER the year below

1901 – [CYEAR] Actual year

9996 [P2YEAR] – [CYEAR], DK which year

9997 Before [P2YEAR], DK exact year

1901 – [P3YEAR]	[P2YEAR] – [CYEAR]	9996. [P2YEAR] – [CYEAR], DK Which Year	9997. Before [P2YEAR], DK Exact Year	DK/RF
GO TO J27CKPT		↓	GO TO J27CKPT	

J8. FU Member: [CYAQRTH], [CYNAMF CYNAML], Age: [AGEIWDATE] [(Respondent)]

What (was/is) [your / [RP / SP]'s] spouse's name?

- ACCEPT any name-do not probe.

String 25

J9. FU Member: [CYAQRTH], [CYNAMF CYNAML], Age: [AGEIWDATE] [(Respondent)]

Before that, [were you / was [he / she]] widowed, divorced, or had [you / he / she] never been married?

2. Never married	3. Widowed	4. Divorced, marriage annulled	7. Other-specify (J9SPEC. Specify (STRING 100))	DK/RF
GO TO J27CKPT		↓	GO TO J12MO	
GO TO J11MO				

J10MO. FU Member: [CYAQRTH], [CYNAMF CYNAML], Age: [AGEIWDATE] [(Respondent)]

In what month and year [were you / was [he / she]] widowed?

- SELECT Month and [Enter] to go to next screen for year
- IF NECESSARY: What would be your best estimate?
- IF NEEDED: I understand that it may be difficult for you to answer these questions, but please do your best.

1. January	2. February	3. March	4. April
5. May	6. June	7. July	8. August
9. September	10. October	11. November	12. December
21. Winter	22. Spring	23. Summer	24. Fall

J10YR. FU Member: [CYAQRTH], [CYNAMF CYNAML], Age: [AGEIWDATE] [(Respondent)]

The month entered is: [J10MO]

- ENTER the year below

1901 – [CYEAR] Actual year

9996 [P2YEAR] – [CYEAR], DK which year

9997 Before [P2YEAR], DK exact year

1901 – [P3YEAR]	[P2YEAR] – [CYEAR]	9996. [P2YEAR] – [CYEAR], DK Which Year	9997. Before [P2YEAR], DK Exact Year
GO TO J27CKPT			

J11MO. FU Member: [CYAQRTH], [CYNAMF CYNAML], Age: [AGEIWDATE] [(Respondent)]

In what month and year did [your / [RP / SP]'s] (divorce/annulment) become final?

- SELECT Month and [Enter] to go to next screen for year
- IF NECESSARY: What would be your best estimate?
- IF NEEDED: I understand that it may be difficult for you to answer these questions, but please do your best.

1. January	2. February	3. March	4. April	5. May	
6. June	7. July	8. August	9. September	10. October	
11. November	12. December	21. Winter	22. Spring	23. Summer	24. Fall

J11YR. FU Member: [CYAQRTH], [CYNAMF CYNAML], Age: [AGEIWDATE] [(Respondent)]

The month entered is: [J11MO]

- ENTER the year below
- 1901 – [CYEAR] Actual year
- 9996 [P2YEAR] – [CYEAR], DK which year
- 9997 Before [P2YEAR], DK exact year

1901 – [P3YEAR]	[P2YEAR] – [CYEAR]	9996. [P2YEAR] – [CYEAR], DK Which Year
9997. Before [P2YEAR], DK Exact Year		

J12MO. FU Member: [CYAQRTH], [CYNAMF CYNAML], Age: [AGEIWDATE] [(Respondent)]

In what month and year did [you / they] stop living together?

- SELECT Month and [Enter] to go to next screen for year
- IF NECESSARY: What would be your best estimate?
- IF NEEDED: I understand that it may be difficult for you to answer these questions, but please do your best.

1. January	2. February	3. March	4. April	5. May	
6. June	7. July	8. August	9. September	10. October	
11. November	12. December	21. Winter	22. Spring	23. Summer	24. Fall

J12YR. FU Member: [CYAQRTH], [CYNAMF CYNAML], Age: [AGEIWDATE] [(Respondent)]

The month entered is: [J12MO]

- ENTER the year below
- 1901 – [CYEAR] Actual year
- 9996 [P2YEAR] – [CYEAR], DK which year
- 9997 Before [P2YEAR], DK exact year

1901 – [P3YEAR]	[P2YEAR] – [CYEAR]	9996. [P2YEAR] – [CYEAR], DK Which Year
9997. Before [P2YEAR], DK Exact Year		

GO TO J27CKPT

END J4_J12

J12A. AQSN of FU Member

J13CKPT. CAI Checkpoint: Marital Status (Type C. J1CKPT=6, 7, 9, 11, 12, 14, 16)

1. Never Married (Marital=2) → GO TO J27CKPT	5. All Others
↓	

Marital Status - Full

SECTION_J [1-24].J14_J26 [1-24]=AQSN of FU Member

J14. FU Member: [CYAQRTH], [CYNAMF CYNAML], Age: [AGEIWDATE] [(Respondent)]

[H/SP LOOP: (Now) I'd like to ask about [your / [RP / SP]'s] family history. / 1st OFUM LOOP: Now let's talk about the other members of the family. / ALL OTHERS: (Now let's talk about the other members of the family.)]
 Altogether, how many times [have you / has [RP / SP / OFUM] been married?

→ GO TO J21MO → GO TO J21MO



J15MO. FU Member: [CYAQRTH], [CYNAMF CYNAML], Age: [AGEIWDATE] [(Respondent)]

In what month and year did [you / he / she] get married for the first time?

- SELECT Month and [Enter] to go to next screen for year
- IF NECESSARY: What would be your best estimate?

1. January	2. February	3. March	4. April	5. May	6. June
7. July	8. August	9. September	10. October	11. November	12. December
21. Winter	22. Spring	23. Summer	24. Fall		

J15YR. FU Member: [CYAQRTH], [CYNAMF CYNAML], Age: [AGEIWDATE] [(Respondent)]

The month entered is: [J15MO]

- ENTER the year below
- 1901 – [CYEAR] Actual year
- 9996 [P2YEAR] – [CYEAR], DK which year
- 9997 Before [P2YEAR], DK exact year

1901 – [P3YEAR]	[P2YEAR] – [CYEAR]	9996. [P2YEAR] – [CYEAR], DK Which Year	9997. Before [P2YEAR], DK Exact Year
-----------------	--------------------	--	---

J16. FU Member: [CYAQRTH], [CYNAMF CYNAML], Age: [AGEIWDATE] [(Respondent)]

What was [your / his / her] first spouse's name?

- ACCEPT any name-do not probe

J17. FU Member: [CYAQRTH], [CYNAMF CYNAML], Age: [AGEIWDATE] [(Respondent)]

Did that marriage end in widowhood, divorce, or what?

3. Widowhood	4. Divorce, marriage annulled	7. Other-specify (J17SPEC. Specify (STRING 100))	DK/RF
--------------	-------------------------------	--	-------



GO TO J19MO

GO TO J20MO

J18MO. FU Member: [CYAQRTH], [CYNAMF CYNAML], Age: [AGEIWDATE] [(Respondent)]

In what month and year [were you / was [he / she]] widowed?

- SELECT Month and [Enter] to go to next screen for year
- IF NECESSARY: What would be your best estimate?

1. January	2. February	3. March	4. April	5. May	6. June
7. July	8. August	9. September	10. October	11. November	12. December
21. Winter	22. Spring	23. Summer	24. Fall		

J18YR. FU Member: [CYAQRTH], [CYNAMF CYNAML], Age: [AGEIWDATE] [(Respondent)]

The month entered is: [J18MO]

- ENTER the year below

1901 – [CYEAR] Actual year

9996 [P2YEAR] – [CYEAR], DK which year

9997 Before [P2YEAR], DK exact year

1901 – [P3YEAR]	[P2YEAR] – [CYEAR]	9996. [P2YEAR] – [CYEAR], DK Which Year	9997. Before [P2YEAR], DK Exact Year
-----------------	--------------------	--	---

GO TO J21MO

J19MO. FU Member: [CYAQRTH], [CYNAMF CYNAML], Age: [AGEIWDATE] [(Respondent)]

In what month and year did [your / his / her] (divorce / annulment) become final?

- SELECT Month and [Enter] to go to next screen for year
- IF NECESSARY: What would be your best estimate?

1. January	2. February	3. March	4. April	5. May	6. June
7. July	8. August	9. September	10. October	11. November	12. December
21. Winter	22. Spring	23. Summer	24. Fall		

J19YR. FU Member: [CYAQRTH], [CYNAMF CYNAML], Age: [AGEIWDATE] [(Respondent)]

The month entered is: [J19MO]

- ENTER the year below

1901 – [CYEAR] Actual year

9996 [P2YEAR] – [CYEAR], DK which year

9997 Before [P2YEAR], DK exact year

1901 – [P3YEAR]	[P2YEAR] – [CYEAR]	9996. [P2YEAR] – [CYEAR], DK Which Year	9997. Before [P2YEAR], DK Exact Year
-----------------	--------------------	--	---

J20MO. FU Member: [CYAQRTH], [CYNAMF CYNAML], Age: [AGEIWDATE] [(Respondent)]

In what month and year did you stop living together?

- SELECT Month and [Enter] to go to next screen for year
- IF NECESSARY: What would be your best estimate?

1. January	2. February	3. March	4. April	5. May	6. June
7. July	8. August	9. September	10. October	11. November	12. December
21. Winter	22. Spring	23. Summer	24. Fall		

J20YR. FU Member: [CYAQRTH], [CYNAMF CYNAML], Age: [AGEIWDATE] [(Respondent)]

The month entered is: [J20MO]

- ENTER the year below

1901 – [CYEAR] Actual year

9996 [P2YEAR] – [CYEAR], DK which year

9997 Before [P2YEAR], DK exact year

1901 – [P3YEAR]	[P2YEAR] – [CYEAR]	9996. [P2YEAR] – [CYEAR], DK Which Year	9997. Before [P2YEAR], DK Exact Year
-----------------	--------------------	--	---

J21MO. FU Member: [CYAQRTH], [CYNAMF CYNAML], Age: [AGEIWDATE] [(Respondent)]

In what month and year did [you / he / she] (last) get married?

- SELECT Month and [Enter] to go to next screen for year
- IF NECESSARY: What would be your best estimate?

1. January	2. February	3. March	4. April	5. May	6. June
7. July	8. August	9. September	10. October	11. November	12. December
21. Winter	22. Spring	23. Summer	24. Fall		

J21YR. FU Member: [CYAQRTH], [CYNAMF CYNAML], Age: [AGEIWDATE] [(Respondent)]

The month entered is: [J21MO]

- ENTER the year below
- 1901 – [CYEAR] Actual year
- 9996 [P2YEAR] – [CYEAR], DK which year
- 9997 Before [P2YEAR], DK exact year

1901 – [P3YEAR]	[P2YEAR] – [CYEAR]	9996. [P2YEAR] – [CYEAR], DK Which Year	9997. Before [P2YEAR], DK Exact Year
-----------------	--------------------	--	---

J22. FU Member: [CYAQRTH], [CYNAMF CYNAML], Age: [AGEIWDATE] [(Respondent)]

What (was / is) [your / his / her] spouse's name?

- ACCEPT any name-do not probe

String 25

J23CKPT. CAI Checkpoint: (For Type C (J1CKPT=6, 7, 9, 11, 12, 14, 16)); Marital Status

1. Widowed (Marital=3)	2. Separated (Marital=5); or Married Partner (Marital=1)	3. Divorced (Marital=4)	4. Married Reference Person, Spouse, OFUM (Marital=1)
↓	GO TO J26MO	GO TO J25MO	GO TO J27CKPT

J24MO. FU Member: [CYAQRTH], [CYNAMF CYNAML], Age: [AGEIWDATE] [(Respondent)]

In what month and year [were you / was [he / she]] widowed?

- SELECT Month and [Enter] to go to next screen for year
- IF NECESSARY: What would be your best estimate?

1. January	2. February	3. March	4. April	5. May	6. June
7. July	8. August	9. September	10. October	11. November	12. December
21. Winter	22. Spring	23. Summer	24. Fall		

J24YR. FU Member: [CYAQRTH], [CYNAMF CYNAML], Age: [AGEIWDATE] [(Respondent)]

The month entered is: [J24MO]

- ENTER the year below
- 1901 – [CYEAR] Actual year
- 9996 [P2YEAR] – [CYEAR], DK which year
- 9997 Before [P2YEAR], DK exact year

1901 – [P3YEAR]	[P2YEAR] – [CYEAR]	9996. [P2YEAR] – [CYEAR], DK Which Year	9997. Before [P2YEAR], DK Exact Year
-----------------	--------------------	--	---

GO TO J27CKPT

J25MO. FU Member: [CYAQRTH], [CYNAMF CYNAML], Age: [AGEIWDATE] [(Respondent)]

In what month and year did [your / his / her] (divorce / annulment) become final?

- SELECT Month and [Enter] to go to next screen for year
- IF NECESSARY: What would be your best estimate?

1. January	2. February	3. March	4. April	5. May	6. June
7. July	8. August	9. September	10. October	11. November	12. December
21. Winter	22. Spring	23. Summer	24. Fall		

J25YR. FU Member: [CYAQRTH], [CYNAMF CYNAML], Age: [AGEIWDATE] [(Respondent)]

The month entered is: [J25MO]

- ENTER the year below
- 1901 – [CYEAR] Actual year
- 9996 [P2YEAR] – [CYEAR], DK which year
- 9997 Before [P2YEAR], DK exact year

1901 – [P3YEAR]	[P2YEAR] – [CYEAR]	9996. [P2YEAR] – [CYEAR], DK Which Year	9997. Before [P2YEAR], DK Exact Year
-----------------	--------------------	--	---

J26MO. FU Member: [CYAQRTH], [CYNAMF CYNAML], Age: [AGEIWDATE] [(Respondent)]

In what month and year did you stop living together?

- SELECT Month and [Enter] to go to next screen for year
- IF NECESSARY: What would be your best estimate?

1. January	2. February	3. March	4. April	5. May	6. June
7. July	8. August	9. September	10. October	11. November	12. December
21. Winter	22. Spring	23. Summer	24. Fall		

J26YR. FU Member: [CYAQRTH], [CYNAMF CYNAML], Age: [AGEIWDATE] [(Respondent)]

The month entered is: [J26MO]

- ENTER the year below
- 1901 – [CYEAR] Actual year
- 9996 [P2YEAR] – [CYEAR], DK which year
- 9997 Before [P2YEAR], DK exact year

1901 – [P3YEAR]	[P2YEAR] – [CYEAR]	9996. [P2YEAR] – [CYEAR], DK Which Year	9997. Before [P2YEAR], DK Exact Year
-----------------	--------------------	--	---

END J14_J26

Biological Children

J27CKPT. CAI Checkpoint: J1Ckpt

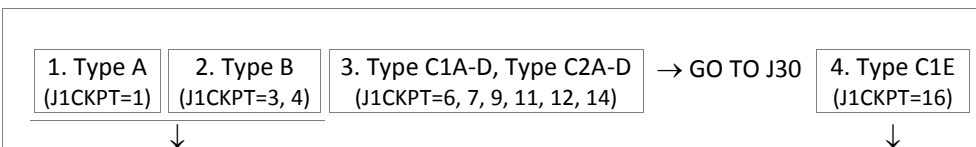

J28. FU Member: [CYAQRTH], [CYNAMF CYNAML], Age: [AGEIWDATE] [(Respondent)]

We are updating the information we collected in [P2YEAR].

TYPEA: Have [you and [RP / SP] / [RP] and [SP]] had any children since [REINT & PYIWDATE=RESPONSE: our last interview on [PYIWDATE] / SO; or REINT & PYIWDATE=NA: January [P2YEAR]]?

TYPEB, TYPEC1E: [CNTOTHKIDS>0: Including [your / his / her] [child / children] ([CNTOTHKIDS]) we already spoke about, [have you / has [RP / SP]] / ALL OTHERS: [Have you / Has [RP / SP]]] [J2 is MALE: fathered / J2 is FEMALE: given birth to] any children since [REINT & PYIWDATE=RESPONSE: our last interview on [PYIWDATE] / SO; or REINT & PYIWDATE=NA: January [P2YEAR]]?

- DO NOT count stillbirths, stepchildren, or adopted children
- [FUMI FU MEMBERS AGE<=2: IWER: FU child(ren) born since [P2YEAR]: [CYNAME, AGEIWDATE, CYAQRTH, CYFUHU]]

1. Yes 5. No → GO TO J32CKPT



J29. FU Member: [CYAQRTH], [CYNAMF CYNAML], Age: [AGEIWDATE] [(Respondent)]

How many is that? (Since [our last interview on [PYIWDATE] / January [P2YEAR]]?)

- [CNTOTHKIDS>0: If needed: Including [your / his / her] [child / children] ([CNTOTHKIDS]) we already spoke about
- [FUMI FU MEMBERS AGE<=2: IWER: FU child(ren) born since [P2YEAR]: [CYNAME, AGEIWDATE, CYAQRTH, CYFUHU]]

1 – 20 → GO TO OTHKID RULE DK/RF → GO TO J32CKPT

J30. FU Member: [CYAQRTH], [CYNAMF CYNAML], Age: [AGEIWDATE] [(Respondent)]

[Now let’s talk about the other members of the family. / (Now, we would like to ask about births of children.)]

[CNTOTHKIDS>0: Including [your / his / her] [child / children] ([CNTOTHKIDS]) we already spoke about, how / ALL OTHERS: How] many children [have you / has [RP / SP / OFUM]] [J2 is MALE: ever fathered / J2 is FEMALE: [yourself] ever given birth to]?

- DO NOT count stillbirths, stepchildren, or adopted children
- [FU MEMBERS AGE<=2 & CYFUHU=FUMI: IWER: FU child(ren) born since [P2YEAR]: CYNAMF CYNAML, AGEIWDATE, CYAQRTH, CYFUHU]

0 → GO TO J32CKPT 1 – 20 DK/RF → GO TO J32CKPT



OTHKID Rule: J1Ckpt; Number of Children for Whom This Person Previously Reported as Other Birth Parent

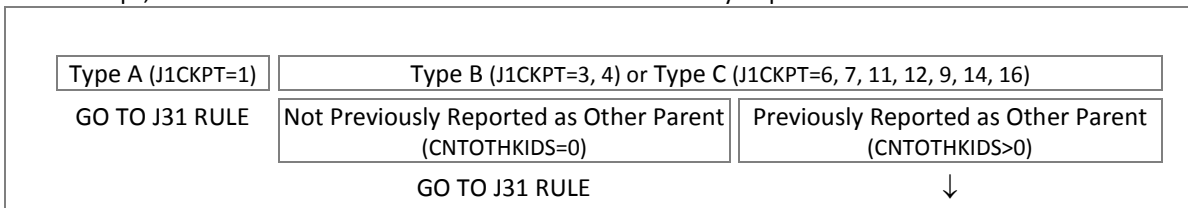

SECTION_J [1-24].OTHKIDTABLE.OTHKIDBLOCK [1-10] [1-24]=AQS of FU Member; [1-10]=Which child previously reported

OTHKID. FU Member: [CYAQRTH], [CYNAMF CYNAML], Age: [AGEIWDATE] [(Respondent)]

IWER: VERIFY each child already reported for [CYNAMF]: Before we go on, I’d like to confirm [your / [RP / SP / OFUM]’s] [CNTOTHKIDS=1: child / CNTOTHKIDS>1: children] we already spoke about:

([First / Next], how about) [J31] ([J31NAML])? ([J31] was reported as [your / [RP / SP / OFUM]’s] child, is that right?)

- ENTER [1] if Child verified as [[CYNAMF CYNAML]’s] child [NAME] [DOB] [PARENT NAME]

1. Yes 5. No

END OTHKIDBLOCK

J31 Rule: Number of Remaining Children (#Children Reported at J29/J30 minus #Children Reported as OTHKID=Yes)

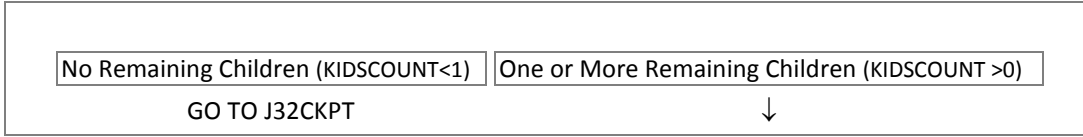

SECTION_J [1-24].J31NAME [1-20] [1-24]=AQSN of FU Member; [1-20]=Which child NOT previously reported

J31. FU Member: [CYAQRTH], [CYNAMF CYNAML], Age: [AGEIWDATE] [(Respondent)]

[LOOP 1: Now let's talk about [your / [RP / SP / OFUM]'s] [OTHKID=YES: other] [CNTJ31KIDS=1: child / CNTJ31KIDS>1: children] / ALL OTHERS: (Now let's talk about [your / [RP / SP / OFUM]'s] [other] [child / children])].

What is [this / the [first / next]] child's name [, including middle and last names / (, including middle and last names)]?

- ENTER First Name
- Ctrl-D and Ctrl-R not allowed; For DK/RF, type [DK] or [RF]

String 25

J31NAMM. FU Member: [CYAQRTH], [CYNAMF CYNAML], Age: [AGEIWDATE] [(Respondent)]

(What is [this / the [first / next]] child's name, including middle and last names?)

- ENTER Middle Name
- Ask for Middle Name but do not probe DK or RF
- If none, PRESS [Enter] to continue
- Ctrl-D and Ctrl-R not allowed; For DK/RF, PRESS [Enter] to continue

String 25

J31NAML. FU Member: [CYAQRTH], [CYNAMF CYNAML], Age: [AGEIWDATE] [(Respondent)]

(What is [this / the [first / next]] child's name, including middle and last names?)

- ENTER Last Name
- Ctrl-D and Ctrl-R not allowed; For DK/RF, type [DK] or [RF]

String 25

OTHPARENTCKPT. CAI Checkpoint: J1Ckpt

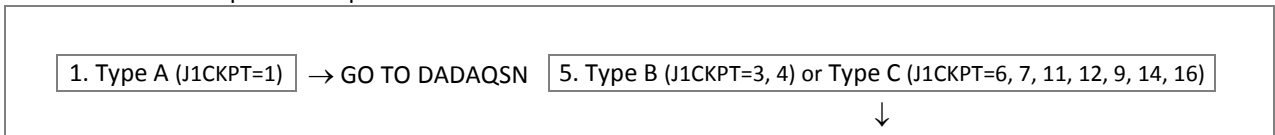

OTHPARENT. FU Member: [CYAQRTH], [CYNAMF CYNAML], Age: [AGEIWDATE] [(Respondent)]

Child: [J31 J31NAMM J31NAML]

Who is [J31]’s [(J31NAML)] birth [J2 IS MALE: mother / J2 IS FEMALE: father]?

- Verify with earlier report from family listing info [F3]
- ENTER [96] if birth parent is not listed and R **cannot or will not** report the parent’s name
- ENTER [97] if birth parent is not listed and R **can** report the parent’s name

1–24. [CYNAMF] [CYNAML], [[ID68], [PN],] [CYAQRTH], [CYFUHU], DOB: [CYBMO/CYBDY/CYBYR], AGE: [AGEIWDATE]	<i>AQSN list of FU Members age 12+ and opposite gender</i>
31–50. [OTHPARENTNAMF OTHPARENTNAML] (Other birth parent of [J31])	<i>List of OthParent=97 for previous children</i>
51–60. Name unknown (Other birth parent of [J31])	<i>List of OthParent=96 for previous children</i>
61–70. Donated sperm/egg or surrogate of [J31]	<i>List of OthParent=95 for previous children</i>
95. Donated sperm/egg; Surrogate	
96. Other person-DK or RF name	DK/RF
	97. Other person-specify name

GO TO DADAQSN/MOMAQSN



SECTION_J [1-24].J31NAME [1-20].PARENTNOTINFU [1-24]=AQSN of FU Member; [1-20]=Which child

OTHPARENTNAMF. FU Member: [CYAQRTH], [CYNAMF CYNAML], Age: [AGEIWDATE] [(Respondent)]

Child: [J31 J31NAMM J31NAML]

What is [her / his] name (first and last names)?

- ENTER Birth [Mother’s / Father’s] First Name
- ENTER names only; do not ENTER [DK, RF, UNKNOWN, etc.]
- If R **cannot or will not** report parent’s name, GO BACK and ENTER [96] at OTHPARENT (other birth parent)

String 25

OTHPARENTNAML. FU Member: [CYAQRTH], [CYNAMF CYNAML], Age: [AGEIWDATE] [(Respondent)]

Child: [J31 J31NAMM J31NAML]

(What is [her / his] name (first and last names)?)

- ENTER Birth [Mother’s / Father’s] First Name
- ENTER names only; do not ENTER [DK, RF, UNKNOWN, etc.]
- If R **cannot or will not** report parent’s name, GO BACK and ENTER [96] at OTHPARENT (other birth parent)

String 25

END PARENTNOTINFU

DADAQSN. AQSN of Child’s Birth Father (J2; or 1-24 if OTHPARENT=1-24; or null if OTHPARENT=31-97, DK/RF)

MOMAQSN. AQSN of Child’s Birth Mother (J2; or 1-24 if OTHPARENT=1-24; or null if OTHPARENT=31-97, DK/RF)

END J31NAME

OS1 Rule: Whether More Children at J29 or J30

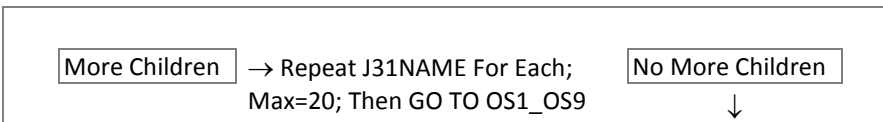

SECTION_J [1-24].OS1_OS9 [1-20] [1-24]=AQSN of FU Member; [1-20]=Which child

OS1. FU Member: [CYAQRTH], [CYNAMF CYNAML], Age: [AGEIWDATE] [(Respondent)]

Child: [J31 J31NAMM J31NAML]

(Now) Let's talk about [J31] ([J31NAML]). (We can't always tell from a name. Is that a male or a female?)

1. Male 2. Female

OS2MO. FU Member: [CYAQRTH], [CYNAMF CYNAML], Age: [AGEIWDATE] [(Respondent)]

Child: [J31 J31NAMM J31NAML]

What is [J31]'s ([J31NAML]) full birthdate?

- **SELECT** Month
- **IF NECESSARY:** What would be your best estimate?

1. January	2. February	3. March	4. April	5. May	6. June
7. July	8. August	9. September	10. October	11. November	12. December
21. Winter	22. Spring	23. Summer	24. Fall		

OS2DY. FU Member: [CYAQRTH], [CYNAMF CYNAML], Age: [AGEIWDATE] [(Respondent)]

Child: [J31 J31NAMM J31NAML]

(What is [J31]'s ([J31NAML]) full birthdate?)

The month entered is: [OS2MO]

- **ENTER** day

OS2YR. FU Member: [CYAQRTH], [CYNAMF CYNAML], Age: [AGEIWDATE] [(Respondent)]

Child: [J31 J31NAMM J31NAML]

The month entered is: [OS2MO]

(What is [J31]'s ([J31NAML]) full birthdate?)

- **ENTER** the year below
- 1901 – [CYEAR] Actual year
 9996 [P2YEAR] – [CYEAR], DK which year
 9997 Before [P2YEAR], DK exact year

1901 – [P3YEAR]	[P2YEAR] – [CYEAR]	9996. [P2YEAR] – [CYEAR], DK Which Year	9997. Before [P2YEAR], DK Exact Year	DK/RF
-----------------	--------------------	--	---	-------

GO TO OS4TOWN

GO TO OS4TOWN

SIGNAL for J28=YES & OS2YR<P2YEAR-CYEAR, 9997: Years prior to [P2YEAR] are not allowed since we are asking about children born since [PYIWDATE]. Please VERIFY child's year of birth.

Birth Year = P2Year-CYear

OS3LBS. FU Member: [CYAQRTH], [CYNAMF CYNAML], Age: [AGEIWDATE] [(Respondent)]

Child: [J31 J31NAMM J31NAML]

How much did [he / she] weigh at birth?

- **ENTER** weight in **POUNDS** and **OUNCES**
- Or **PRESS [Enter]** to go to next screen for kilograms

→ GO TO OS3KILO → GO TO OS3A



OS3OZ. FU Member: [CYAQRTH], [CYNAMF CYNAML], Age: [AGEIWDATE] [(Respondent)]
 Child: [J31 J31NAMM J31NAML]
 • The weight in pounds entered is: [OS3LBS]
 • ENTER the OUNCES

GO TO OS10A

OS3KILO. FU Member: [CYAQRTH], [CYNAMF CYNAML], Age: [AGEIWDATE] [(Respondent)]
 Child: [J31 J31NAMM J31NAML]
 (How much did [he / she] weigh at birth?)
 • ENTER weight in KILOGRAMS

→ GO TO OS10A



OS3A. FU Member: [CYAQRTH], [CYNAMF CYNAML], Age: [AGEIWDATE] [(Respondent)]
 Child: [J31 J31NAMM J31NAML]

Did [he / she] weigh more than 5-1/2 pounds (2500 grams) or less than 5-1/2 pounds (2500 grams), or what?



GO TO OS10A

OS3B. FU Member: [CYAQRTH], [CYNAMF CYNAML], Age: [AGEIWDATE] [(Respondent)]
 Child: [J31 J31NAMM J31NAML]

Did [he / she] weigh more than 9 pounds (4100 grams) or less than 9 pounds (4100 grams), or what?

Birth Year = P2Year-CYear

OS10A. FU Member: [CYAQRTH], [CYNAMF CYNAML], Age: [AGEIWDATE] [(Respondent)]
 Child: [J31 J31NAMM J31NAML]

What was [his / her] length at birth?

- ENTER length in INCHES
- Or PRESS [Enter] to go to next screen for centimeters

→ GO TO OS10B → GO TO OS10C



OS10CENT. FU Member: [CYAQRTH], [CYNAMF CYNAML], Age: [AGEIWDATE] [(Respondent)]
 Child: [J31 J31NAMM J31NAML]

(What was [his / her] length at birth?)

- ENTER length in CENTIMETERS

→ GO TO OS10C



OS10B. FU Member: [CYAQRTH], [CYNAMF CYNAML], Age: [AGEIWDATE] [(Respondent)]
 Child: [J31 J31NAMM J31NAML]

INTERVIEWER: Did R indicate that the length of the baby was an estimate?

Birth Year = P2Year-CYear

OS10C. FU Member: [CYAQRTH], [CYNAMF CYNAML], Age: [AGEIWDATE] [(Respondent)]
 Child: [J31 J31NAMM J31NAML]

Did [MOMAQSN=RESPAQSN: you / OTHPARENT=1-50, 97: [MOTHER] / OTHPARENT=95, 96, DK/RF: [J31]'s ([J31NAML]) mother] breastfeed [J31] ([J31NAML]) at all?

- ENTER [1] for any amount of breastfeeding by R
- ENTER [1] if R only expressed or pumped breastmilk to be fed to the baby
- ENTER [1] if R is still breastfeeding this child

1. Yes 5. No

OS4TOWN. FU Member: [CYAQRTH], [CYNAMF CYNAML], Age: [AGEIWDATE] [(Respondent)]
 Child of FU Member: [J31 J31NAMM J31NAML]

In what city and state was [he / she] [J31] ([J31NAML]) born?

- ENTER City and go to next screen for State
- For Don't Know, ENTER [Ctrl D]
- For Refusal, ENTER [Ctrl R]

String 25

OS4STATE. FU Member: [CYAQRTH], [CYNAMF CYNAML], Age: [AGEIWDATE] [(Respondent)]
 Child: [J31 J31NAMM J31NAML]

(What is the State?)

[OS4TOWN]

- Start typing the name of the State to bring up the look-up list
- For foreign country birth, ENTER [FOR] to select "Foreign Country" from the state list

String 30; U.S State → GO TO OS5 Foreign Country DK/RF → GO TO OS5



OS4COUNTRY. FU Member: [CYAQRTH], [CYNAMF CYNAML], Age: [AGEIWDATE] [(Respondent)]
 Child: [J31 J31NAMM J31NAML]

What is the Country?

[OS4TOWN], [OS4STATE]

- Start typing the name of the Foreign Country to bring up the look-up list

String 25; Country

OS5. FU Member: [CYAQRTH], [CYNAMF CYNAML], Age: [AGEIWDATE] [(Respondent)]
 Child: [J31 J31NAMM J31NAML]

Is [J31] ([J31NAML]) living with [you / [RP / SP / OFUM]] now, away with [his / her] [J2 IS FEMALE: father / J2 IS MALE: mother], with some other relative, (has [he/she] set up a separate household), or what?

- If R says "adopted out", PROBE: Was that to a relative or to a non-relative?

1. Living in FU now	7. Other-specify (OS5SPEC. Specify (STRING 100))
2. Living with father elsewhere	8. Adopted out to relative
3. Living with mother elsewhere	9. Adopted out to non-relative
4. Living with other relative elsewhere	10. Adopted out; don't know/refused to whom
5. Set up a separate household	6. Deceased
	11. Fostered out
	DK/RF

GO TO OS7



GO TO OS7

OS6MO. FU Member: [CYAQRTH], [CYNAMF CYNAML], Age: [AGEIWDATE] [(Respondent)]

Child: [J31 J31NAMM J31NAML]

In what month and year did [he / she] die?

- SELECT Month and [Enter] to go to next screen for year
- IF NECESSARY: What would be your best estimate?

1. January	2. February	3. March	4. April	5. May	6. June
7. July	8. August	9. September	10. October	11. November	12. December
21. Winter	22. Spring	23. Summer	24. Fall		

OS6YR. FU Member: [CYAQRTH], [CYNAMF CYNAML], Age: [AGEIWDATE] [(Respondent)]

Child: [J31 J31NAMM J31NAML]

The month entered is: [OS6MO]

- ENTER the year below
- 1901 – [CYEAR] Actual year
- 9996 [P2YEAR] – [CYEAR], DK which year
- 9997 Before [P2YEAR], DK exact year

1901 – [P3YEAR]	[P2YEAR] – [CYEAR]	9996. [P2YEAR] – [CYEAR], DK Which Year	9997. Before [P2YEAR], DK Exact Year
-----------------	--------------------	--	---

GO TO OS8 RULE

OS7. FU Member: [CYAQRTH], [CYNAMF CYNAML], Age: [AGEIWDATE] [(Respondent)]

Child: [J31 J31NAMM J31NAML]

Is [he / she] Spanish, Hispanic, or Latino? That is, Mexican, Mexican American, Chicano, Puerto Rican, Cuban, or other Spanish?

0. Not Spanish/Hispanic	1. Mexican	2. Mexican American	3. Chicano
4. Puerto Rican	5. Cuban	7. Other-specify (OS7SPEC. Specify (STRING 100))	

OS8. FU Member: [CYAQRTH], [CYNAMF CYNAML], Age: [AGEIWDATE] [(Respondent)]

Child: [J31 J31NAMM J31NAML]

What is [his / her] race? Is [he / she] white, black, American Indian, Alaska Native, Asian, Native Hawaiian, or Pacific Islander?

- ENTER all that apply
- PROBE: Any others?

1. White	2. Black, African-American, or Negro	
3. American Indian or Alaska Native	5. Native Hawaiian	6. Pacific Islander
7. Other-specify (OS8SPEC. Specify (STRING 100))	DK/RF	4. Asian

GO TO OS8 RULE



OS8A. FU Member: [CYAQRTH], [CYNAMF CYNAML], Age: [AGEIWDATE] [(Respondent)]

Child: [J31 J31NAMM J31NAML]

Would that be Chinese, Filipino, Asian Indian, or what?

1. Chinese	2. Filipino	3. Asian Indian	4. Japanese	5. Korean	6. Vietnamese
7. Other Asian-specify (OS8ASPEC. Specify (STRING 100))					

OS8 Rule: Whether More Children at J29 or J30

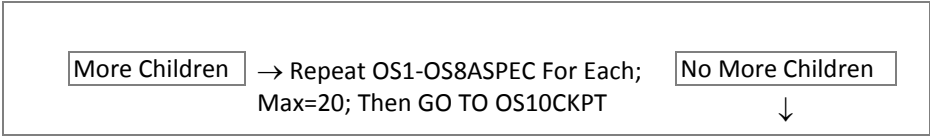

OS10CKPT. CAI Checkpoint: Whether Child Is Newborn & Not Adopted Out

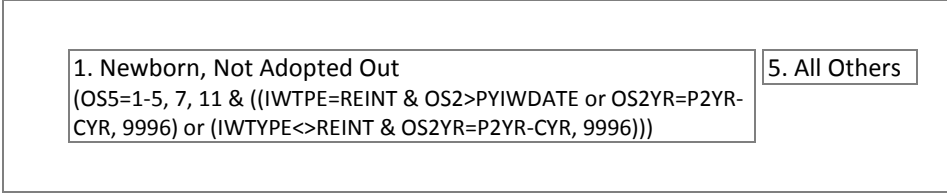

Birth Year = P2Year-CYear and Not Adopted Out

OS71CKPT. CAI Checkpoint: Whether Multiple Newborns Not Adopted Out & Have Same Birthdate +/- 1 Day

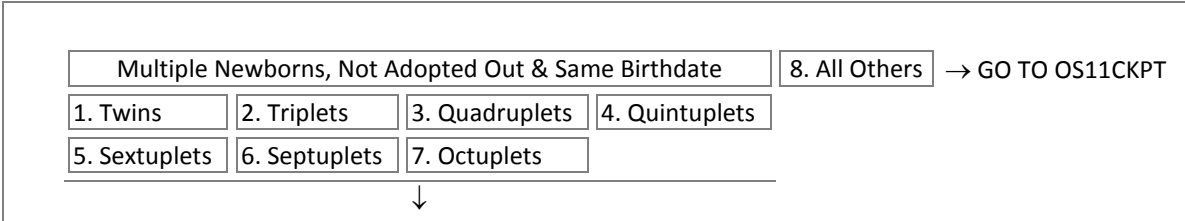

END OS1_OS9

Biological Newborn-Multiple Birth

SECTION_J [1-24].MULTIPLE [1-10] [1-24]=AQSN of FU Member; [1-10]=Which multiple birth

OS71. Child [1-8]: [J31 J31NAMM J31NAML], DOB: [OS2BMO/OS2BDY/OS2BYR]

Is it correct that [J31] ([J31NAML]) [and [J31] ([J31NAML])...] are [twins / triplets / quadruplets / quintuplets / sextuplets / septuplets / octuplets]?

1. Yes 5. No → GO TO OS11CKPT

↓

OS72. Child [1-8]: [J31 J31NAMM J31NAML], DOB: [OS2BMO/OS2BDY/OS2BYR]

Are they identical [twins / triplets / quadruplets / quintuplets / sextuplets / septuplets / octuplets] or are they fraternal [twins / triplets / quadruplets / quintuplets / sextuplets / septuplets / octuplets]?

- IF [twins / triplets / quadruplets / quintuplets / sextuplets / septuplets / octuplets] are not the same sex, they are fraternal

1. Identical 2. Fraternal DK/RF → GO TO OS74

↓

OS73. Child [1-8]: [J31 J31NAMM J31NAML], DOB: [OS2BMO/OS2BDY/OS2BYR]

How do you know they are [identical / fraternal] [twins / triplets / quadruplets / quintuplets / sextuplets / septuplets / octuplets]?

- ENTER all that apply
- PROBE: Any others?

1. Cheek swab DNA test	2. Blood DNA test
3. Placental membrane DNA test	4. Blood typing test
5. Observation of placenta	6. Doctor/midwife told me
7. Completed a questionnaire	8. Someone else not present at delivery told me
[OS72=FRATERNAL: 9. Newborns of different gender]	
97. Other-specify (OS73SPEC. Please specify. (String 100))	

OS74. Child [1-8]: [J31 J31NAMM J31NAML], DOB: [OS2BMO/OS2BDY/OS2BYR]

Are they often mistaken for each other, or are they different enough to tell apart?

1. Often mistaken for one another	2. Different enough to tell apart
-----------------------------------	-----------------------------------

END MULTIPLE

Biological Newborn

SECTION_J [1-24].NEWBORNNOTADP [1-10] [1-24]=AQSN of FU Member; [1-10]=Which birth

OS11CKPT. CAI Checkpoint: Whether Newborn is Single or Multiple Birth

1. Single Birth; or 1 st Newborn of Multiple Birth	5. Other Newborn of Multiple Birth	→ GO TO OS28CKPT
↓		

OSAQSN. AQSN of FU Member

DADAQSN. AQSN of Child's Birth Father

MOMAQSN. AQSN of Child's Birth Mother

OS11_1CKPT. CAI Checkpoint: Whether R is Parent of Newborn

1. R=Parent (RESPAQSN=MOMAQSN or DADAQSN)	→ GO TO OS11	5. All Others
↓		

OS11_1. FU Member: [CYAQRTH], [CYNAMF CYNAML], Age: [AGEIWDATE] [(Respondent)]

Child [1-8]: [J31 J31NAMM J31NAML]

Next are some questions about [MOMAQSN=RESPAQSN: your / OTHPARENT=1-50, 97: [MOTHER]'s / OTHPARENT=51-70, 95, 96, DK/RF: [J31]'s ([J31NAML]) mother's] pregnancy and the birth of [[J31] ([J31NAML]) / the [twins / triplets / quadruplets / quintuplets / sextuplets / septuplets / octuplets]].

Would you be able to answer these questions?

1. Yes	5. No	DK/RF
--------	-------	-------

↓ GO TO OS64 RULE

OS11. FU Member: [CYAQRTH], [CYNAMF CYNAML], Age: [AGEIWDATE] [(Respondent)]

Child [1-8]: [J31 J31NAMM J31NAML]

How many weeks pregnant [*MOMAQSN=RESPAQSN*: were you / *OTHPARENT=1-50, 97*: was [MOTHER] / *OTHPARENT=51-70, 95, 96, DK/RF*: was [J31]'s ([J31NAML]) [and [J31]'s ([J31NAML]) ...] mother] when [you / she] learned that [you were / she was] pregnant with [J31]([J31NAML]) [and [J31]([J31NAML]) ...]?

- ENTER number of weeks
- Weeks of pregnancy should be counted as completed weeks since the last normal menstrual period.

→ GO TO OS13



OS12. FU Member: [CYAQRTH], [CYNAMF CYNAML], Age: [AGEIWDATE] [(Respondent)]

Child [1-8]: [J31 J31NAMM J31NAML]

Was it less than three months, more than three months, or what?

GO TO OS13



GO TO OS13

OS12A. FU Member: [CYAQRTH], [CYNAMF CYNAML], Age: [AGEIWDATE] [(Respondent)]

Child [1-8]: [J31 J31NAMM J31NAML]

Was it less than six months, more than six months, or what?

OS13. FU Member: [CYAQRTH], [CYNAMF CYNAML], Age: [AGEIWDATE] [(Respondent)]

Child [1-8]: [J31 J31NAMM J31NAML]

In the 6 months before [you / [MOTHER] / [J31]'s ([J31NAML]) [and [J31]'s ([J31NAML])...] mother] found out [you were / she was] pregnant (with [J31] ([J31NAML]) [and [J31] ([J31NAML])...]), how many cigarettes did [you / she] smoke a day, on average?

- DEFINITION: A standard pack of American cigarettes contains 20 cigarettes

→ GO TO OS16 → GO TO OS16



OS14. FU Member: [CYAQRTH], [CYNAMF CYNAML], Age: [AGEIWDATE] [(Respondent)]

Child [1-8]: [J31 J31NAMM J31NAML]

After before [you / [MOTHER] / [J31]'s ([J31NAML]) [and [J31]'s ([J31NAML]) ...] mother] found out [you were / she was] pregnant this time (with [J31] ([J31NAML]) [and [J31] ([J31NAML]) ...]), did [you / she] smoke cigarettes at all during the pregnancy?

→ GO TO OS16



OS15. FU Member: [CYAQRTH], [CYNAMF CYNAML], Age: [AGEIWDATE] [(Respondent)]

Child [1-8]: [J31 J31NAMM J31NAML]

On average, how many cigarettes before [you / [MOTHER] / [J31]'s ([J31NAML]) [and [J31]'s ([J31NAML])...] mother] smoke per day after [you / she] found out that [you were / she was] pregnant this time (with [J31] ([J31NAML]) [and [J31] ([J31NAML])...])?

- DEFINITION: A standard pack of American cigarettes contains 20 cigarettes

OS16. FU Member: [CYAQRTH], [CYNAMF CYNAML], Age: [AGEIWDATE] [(Respondent)]

Child [1-8]: [J31 J31NAMM J31NAML]

Did [you / [MOTHER] / [J31]'s ([J31NAML]) [and [J31]'s ([J31NAML]) ...] mother] drink any alcoholic beverages, including beer, wine, or liquor, during the 12 months before [J31] ([J31NAML]) [and [J31] ([J31NAML]) ...] [was / were] born?

1. Yes 5. No → GO TO OS19



OS17. FU Member: [CYAQRTH], [CYNAMF CYNAML], Age: [AGEIWDATE] [(Respondent)]

Child [1-8]: [J31 J31NAMM J31NAML]

During [your / that] pregnancy, on average, how often did [you / she] have any alcohol to drink? Would you say: never, less than once a month, about once a month, several times a month, about once a week, several times a week, or every day?

<input type="checkbox"/> 1. Never	<input type="checkbox"/> 2. Less than once a month	<input type="checkbox"/> 3. About once a month
<input type="checkbox"/> 4. Several times a month	<input type="checkbox"/> 5. About once a week	<input type="checkbox"/> 6. Several times a week
		<input type="checkbox"/> 7. Every day

OS19. FU Member: [CYAQRTH], [CYNAMF CYNAML], Age: [AGEIWDATE] [(Respondent)]

Child [1-8]: [J31 J31NAMM J31NAML]

Was a cesarean delivery done?

- IF NECESSARY, PROBE: (Was/Were) [J31] ([J31NAML]) [and [J31] ([J31NAML])...] delivered by an incision in before [your / [MOTHER]'s / [J31]'s ([J31NAML]) [and [J31]'s ([J31NAML])...] mother's] abdomen?

1. Yes 5. No → GO TO OS23Months



OS20. FU Member: [CYAQRTH], [CYNAMF CYNAML], Age: [AGEIWDATE] [(Respondent)]

Child [1-8]: [J31 J31NAMM J31NAML]

Was this [your / [MOTHER]'s / [J31]'s ([J31NAML]) [and [J31]'s ([J31NAML])...] mother's] first cesarean delivery, or did [you / she] have one before?

1. Yes, first cesarean 5. No, had cesarean before

OS23Months. FU Member: [CYAQRTH], [CYNAMF CYNAML], Age: [AGEIWDATE] [(Respondent)]

Child [1-8]: [J31 J31NAMM J31NAML]

How many months or weeks had [you / [MOTHER] / [J31]'s ([J31NAML]) [and [J31]'s ([J31NAML])...] mother] been pregnant when [J31] ([J31NAML]) [and [J31] ([J31NAML])...] [was / were] born?

- ENTER number of months here and number of weeks on next screen
- ENTER [0] if R reports number of weeks only
- PROBE for an exact number; Fill fields for both months and weeks as R reports them. For example:
 "2 1/2 months" should be entered as 2 months and 2 weeks
 "9 months" would be entered as 9 months and 0 weeks.
 "40 weeks" would be entered as 0 months and 40 weeks

0 – 10 DK/RF → GO TO OS24



OS23Weeks. [FU Member: [CYAQRTH], [CYNAMF CYNAML], Age: [AGEIWDATE] [(Respondent)]

Child [1-8]: [J31 J31NAMM J31NAML]

(How many months or weeks had [you / [MOTHER] / [J31]'s ([J31NAML]) [and [J31]'s ([J31NAML])...] mother] been pregnant when [J31] ([J31NAML]) [and [J31] ([J31NAML])...] [was / were] born?)

- ENTER number of weeks
- ENTER [0] for None
- PROBE for an exact number; Fill fields for both months and weeks as R reports them. For example: "2 1/2 months" should be entered as 2 months and 2 weeks
"9 months" would be entered as 9 months and 0 weeks.
"40 weeks" would be entered as 0 months and 40 weeks

→ GO TO OS27 → GO TO OS24

SIGNAL for OS23MONTHS+OS23WEEKS <6 MOS/24 WKS OR >10 MOS/44 WKS (& RESPONSE): [R has reported a \[<6 MOS/24 WKS: live birth occurring earlier than 24 weeks or 6 months of pregnancy / >10 MOS/44 WKS: pregnancy longer than 44 weeks or 10 months\]. This is extremely unlikely. Please correct the months or weeks of gestation, if necessary. If you suppress this check, please enter an F2 comment for the reason.](#)

OS24. [FU Member: [CYAQRTH], [CYNAMF CYNAML], Age: [AGEIWDATE] [(Respondent)]

Child [1-8]: [J31 J31NAMM J31NAML]

A preterm delivery is one that occurs at 36 weeks or earlier in pregnancy. As far as you know, did you / [MOTHER] / [J31]'s ([J31NAML]) [and [J31]'s ([J31NAML])...] mother] have a preterm delivery?

OS27. [FU Member: [CYAQRTH], [CYNAMF CYNAML], Age: [AGEIWDATE] [(Respondent)]

Child [1-8]: [J31 J31NAMM J31NAML]

When [J31] ([J31NAML]) [and [J31] ([J31NAML])...] [was / were] born, how was the delivery bill paid?

- ENTER all that apply
- PROBE: Any other ways?
- IF needed/IF R mentions the name of the provider: Was it paid using employer provided health insurance, private health insurance, a government program like Medicare or Medicaid, out of pocket, or what?
- IF R mentions government plan: Is that Medicare, Medi-gap, Medicaid or a state program, military provided such as Tricare, ChampUS or ChampVA, Indian health insurance, or some other plan?
- IF needed (if Affordable Care Act/Obamacare/Health Insurance Exchanges mentioned): Was that a privately purchased health insurance plan or Medicaid/[STATEMEDPROG]/[SCHIPNAME]?
- If R says "bill still unpaid", ASK: How do you think that bill will be paid?
- Do not include costs of prenatal care, only costs of the delivery and any follow-up care.

1. Employer provided health insurance (Current or former employer)	2. Private health insurance purchased
5. Medicaid/[STATEMEDPROG]/[SCHIPNAME]	6. Military Health Care/Tricare (Active duty)
7. TRICARE/CHAMPUS/CHAMP-VA (Dependents, Veterans)	8. Indian Health Insurance
11. Veterans Administration (VA)	12. Out-of-pocket
13. No payment required (IF VOL)	
97. Other-specify (OS27SPEC. Specify (String 100))	

OS28CKPT. CAI Checkpoint: Whether Newborn Living or Deceased

<input type="text" value="1. Newborn Living (OS5<>6)"/>	<input type="text" value="5. Newborn Deceased (OS5=6)"/>	→ GO TO OS33 RULE
↓		

SECTION_J[1-24].NEWBORNNOTADP[1-10].OS28B32[1-8] [1-24]=AQS of FU Member; [1-10]=Which birth; [1-8]=Which child

OS28. FU Member: [CYAQRTH], [CYNAMF CYNAML], Age: [AGEIWDATE] [(Respondent)]

Child: [J31 J31NAMM J31NAML]

[(And)] How many days did [J31] ([J31NAML]) stay in the hospital?

- ENTER number of days
- ENTER [994] if baby still in hospital
- ENTER [995] if less than 1 day (less than 24 hours)
- ENTER [996] if baby not born in a hospital
- ENTER [997] if baby did not stay in hospital

1 – 150	994. Still in hospital (IF VOL)	995. < 1 day (IF VOL)	DK/RF	996. Not born in hospital (IF VOL)
				997. Didn't stay in hospital (IF VOL)



GO TO OS40 RULE

OS30. FU Member: [CYAQRTH], [CYNAMF CYNAML], Age: [AGEIWDATE] [(Respondent)]

Child: [J31 J31NAMM J31NAML]

Did [J31] ([J31NAML]) receive any newborn care in an intensive care unit, premature nursery, or any other type of special care facility?

1. Yes 5. No → GO TO OS40 RULE



OS31. [FU Member: [CYAQRTH], [CYNAMF CYNAML], Age: [AGEIWDATE] [(Respondent)]

Child: [J31 J31NAMM J31NAML]

How many days did [J31] ([J31NAML]) stay in this special care facility after birth?

- ENTER number of days

1 – 150 994. Baby still in special care facility

OS32. [FU Member: [CYAQRTH], [CYNAMF CYNAML], Age: [AGEIWDATE] [(Respondent)]

Child: [J31 J31NAMM J31NAML]

Did [J31] ([J31NAML]) require assisted ventilation for more than 30 minutes?

1. Yes 5. No → GO TO OS40 RULE



OS33. [FU Member: [CYAQRTH], [CYNAMF CYNAML], Age: [AGEIWDATE] [(Respondent)]

Child: [J31 J31NAMM J31NAML]

How many days did [J31] ([J31NAML]) require ventilation?

- ENTER number of days

1 – 150

END OS28B32

OS33 Rule: Whether Newborn is Single or Multiple Birth

Single Birth; or No More Newborns of Multiple Birth (OS11CKPT=1)	More Newborns of Multiple Birth (OS11CKPT=5)	→ Repeat OS28B32 For Each; Then GO TO OS40 RULE
↓		

OS40 Rule: Whether Newborn is Single or Multiple Birth

Single Birth; or 1 st Newborn of Multiple Birth (OS11CKPT=1)	Other Newborn of Multiple Birth (OS11CKPT=5)	→ GO TO OS64 RULE
↓		

OS40. [FU Member: [CYAQRTH], [CYNAMF CYNAML], Age: [AGEIWDATE] [(Respondent)]

Child [1-8]: [J31 J31NAMM J31NAML]

When [you were / [MOTHER] was / [J31]'s ([J31NAML]) [and [J31]'s ([J31NAML])...] mother was], did [you / she] ever visit a doctor or other medical care provider for prenatal care, that is, for one or more pregnancy check-ups?

- Include visits to a midwife or birthing center

1. Yes 5. No → GO TO OS51



OS41. [FU Member: [CYAQRTH], [CYNAMF CYNAML], Age: [AGEIWDATE] [(Respondent)]

Child [1-8]: [J31 J31NAMM J31NAML]

How many weeks pregnant [were you / was [MOTHER] / was [J31]'s ([J31NAML]) [and [J31]'s ([J31NAML])...] mother] at the time of [your / her] first prenatal care visit?

- ENTER number of weeks completed since the last normal menstrual period
- Weeks of pregnancy should be counted as completed weeks since the last normal menstrual period.
- Include visits to a midwife or birthing center

1 - 40 → GO TO OS43 DK/RF



OS42. [FU Member: [CYAQRTH], [CYNAMF CYNAML], Age: [AGEIWDATE] [(Respondent)]

Child [1-8]: [J31 J31NAMM J31NAML]

Was it less than three months, more than three months, or what?

1. Less than 3 months 2. More than 3 months 3. About 3 months DK/RF

GO TO OS43



GO TO OS43

OS42A. [FU Member: [CYAQRTH], [CYNAMF CYNAML], Age: [AGEIWDATE] [(Respondent)]

Child [1-8]: [J31 J31NAMM J31NAML]

Was it less than six months, more than six months, or what?

1. Less than 6 months 2. More than 6 months 3. About 6 months

OS43. [FU Member: [CYAQRTH], [CYNAMF CYNAML], Age: [AGEIWDATE] [(Respondent)]

Child [1-8]: [J31 J31NAMM J31NAML]

How many visits to a doctor or other medical care provider for prenatal care did [you / [MOTHER] / [J31]'s ([J31NAML]) [and [J31]'s ([J31NAML])...] mother] have when [you were / she was] pregnant (with [J31] ([J31NAML]) [and [J31] ([J31NAML]) ...])?

- ENTER number of prenatal care visits
- Do not include visits for WIC (Women, Infants, and Children nutritional program)
- Include visits to a midwife or birthing center

1 - 94

OS47. [FU Member: [CYAQRTH], [CYNAMF CYNAML], Age: [AGEIWDATE] [(Respondent)]

Child [1-8]: [J31 J31NAMM J31NAML]

Where did [you / [MOTHER] / [J31]'s ([J31NAML]) [and [J31]'s ([J31NAML])...] mother] go [OS43<>1: most of the time] for [your / her] prenatal [OS43=1: visit / ALL OTHERS: visits] with a doctor or other medical care provider?

- Do not include visits for WIC (Women, Infants, and Children nutritional program)
- Include visits to a midwife or birthing center

1. Clinic or health center 2. Doctor's office or HMO 3. Hospital emergency room

4. Hospital outpatient department 5. Midwife/birthing center 6. Some other place

7. Didn't go to one place most often

OS48. [FU Member: [CYAQRTH], [CYNAMF CYNAML], Age: [AGEIWDATE] [(Respondent)]

Child [1-8]: [J31 J31NAMM J31NAML]

How was [your / [MOTHER]'s / [J31]'s ([J31NAML]) [and [J31]'s ([J31NAML])...] mother's] prenatal care paid for?

- ENTER all that apply
- PROBE: Any other ways?
- IF needed/IF R mentions the name of the provider: Was it paid using employer provided health insurance, private health insurance, a government program like Medicare or Medicaid, out of pocket, or what?
- IF R mentions government plan: Is that Medicare, Medi-gap, Medicaid or a state program, military provided such as Tricare, ChampUS or ChampVA, Indian health insurance, or some other plan?
- IF needed (if Affordable Care Act/Obamacare/Health Insurance Exchanges mentioned): Was that a privately purchased health insurance plan or Medicaid/[STATEMEDPROG]/[SCHIPNAME]?
- If R says "bill still unpaid", ASK: How do you think that bill will be paid?

1. Employer provided health insurance (Current or former employer)	2. Private health insurance purchased
5. Medicaid/[STATEMEDPROG]/[SCHIPNAME]	6. Military Health Care/Tricare (Active duty)
7. TRICARE/CHAMPUS/CHAMP-VA (Dependents, Veterans)	8. Indian Health Insurance
11. Veterans Administration (VA)	12. Out-of-pocket
13. No payment required (IF VOL)	
97. Other-specify (OS48SPEC. Specify (String 100))	

OS51. [FU Member: [CYAQRTH], [CYNAMF CYNAML], Age: [AGEIWDATE] [(Respondent)]

Child [1-8]: [J31 J31NAMM J31NAML]

What was [your / [MOTHER]'s / [J31]'s ([J31NAML]) [and [J31]'s ([J31NAML])...] mother's] weight just before [you / she] delivered?

- ENTER weight in POUNDS
- Or PRESS [Enter] to continue to next screen for kilograms
- If more than 400 pounds, ENTER [400]

[ENTER]	80 – 400	DK/RF
---------	----------	-------

↓ GO TO OS52

OS51KILO. [FU Member: [CYAQRTH], [CYNAMF CYNAML], Age: [AGEIWDATE] [(Respondent)]

Child [1-8]: [J31 J31NAMM J31NAML]

(What was [your / [MOTHER]'s / [J31]'s ([J31NAML]) [and [J31]'s ([J31NAML])...] mother's] weight just before [you / she] delivered?)

- ENTER weight in KILOGRAMS
- If more than 180 kilograms, ENTER [180]

36.0 – 180.0

OS52. [FU Member: [CYAQRTH], [CYNAMF CYNAML], Age: [AGEIWDATE] [(Respondent)]

Child [1-8]: [J31 J31NAMM J31NAML]

What was [your / [MOTHER]'s / [J31]'s ([J31NAML]) [and [J31]'s ([J31NAML])...] mother's] weight just before [you / she] became pregnant (with [J31] [and [J31]...])?

- ENTER weight in POUNDS
- Or PRESS [Enter] to continue to next screen for kilograms
- If more than 400 pounds, ENTER [400]

[ENTER]	80 – 400	DK/RF
---------	----------	-------

↓ GO TO OS53CKPT

OS52KILO. [FU Member: [CYAQRTH], [CYNAMF CYNAML], Age: [AGEIWDATE] [(Respondent)]

Child [1-8]: [J31 J31NAMM J31NAML]

(What was [you / [MOTHER]'s / [J31]'s ([J31NAML]) [and [J31]'s ([J31NAML])...] mother's] weight just before [you / she] became pregnant (with [J31] ([J31NAML]) [and [J31] ([J31NAML])...])?)

- ENTER weight in **KILOGRAMS**
- If more than 180 kilograms, ENTER [180]

36.0 – 180.0

OS53CKPT. CAI Checkpoint: Whether Weight Loss, Gain, or No Change (1 LB=0.45 KG; 1 KG=2.2 LB)

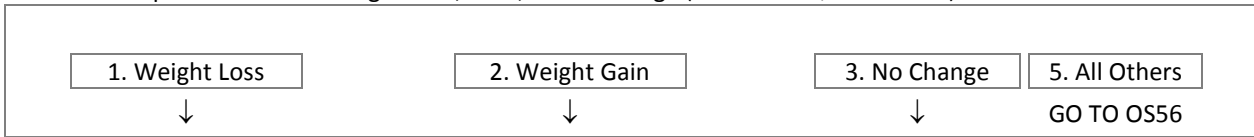

OS53. [FU Member: [CYAQRTH], [CYNAMF CYNAML], Age: [AGEIWDATE] [(Respondent)]
Child [1-8]: [J31 J31NAMM J31NAML]
Does that mean that [you / she] lost [[OS52] minus [OS51]] pounds ([[OS52KILO] minus [OS51KILO]] kilograms) during [your / her] pregnancy?

- IF necessary, verify weights and go back to correct
- Weight before delivery: [OS51] pounds ([OS51KILO] kilograms)
- Weight before pregnancy: [OS52] pounds ([OS52KILO] kilograms)

1. Yes 5. No

GO TO OS58CKPT

OS54. [FU Member: [CYAQRTH], [CYNAMF CYNAML], Age: [AGEIWDATE] [(Respondent)]
Child [1-8]: [J31 J31NAMM J31NAML]
Does that mean that [you / she] gained [[OS51] minus [OS52]] pounds ([[OS51KILO] minus [OS52KILO]] kilograms) during [your / her] pregnancy?

- IF necessary, verify weights and go back to correct
- Weight before delivery: [OS51] pounds ([OS51KILO] kilograms)
- Weight before pregnancy: [OS52] pounds ([OS52KILO] kilograms)

1. Yes 5. No

GO TO OS58CKPT

OS55. [FU Member: [CYAQRTH], [CYNAMF CYNAML], Age: [AGEIWDATE] [(Respondent)]
Child [1-8]: [J31 J31NAMM J31NAML]
Does that mean that [you / she] did not gain or lose any weight during [your / her] pregnancy?

- IF necessary, verify weights and go back to correct
- Weight before delivery: [OS51] pounds ([OS51KILO] kilograms)
- Weight before pregnancy: [OS52] pounds ([OS52KILO] kilograms)

1. Yes 5. No

GO TO OS58CKPT

OS56. FU Member: [CYAQRTH], [CYNAMF CYNAML], Age: [AGEIWDATE] [(Respondent)]

Child [1-8]: [J31 J31NAMM J31NAML]

Did [you / [MOTHER] / [J31]'s ([J31NAML]) [and [J31]'s ([J31NAML])...] mother] gain or lose weight during [your / her] pregnancy (with [J31] ([J31NAML]) [and [J31] ([J31NAML]) ...])?

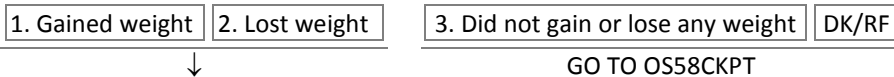

OS57. [FU Member: [CYAQRTH], [CYNAMF CYNAML], Age: [AGEIWDATE] [(Respondent)]

Child [1-8]: [J31 J31NAMM J31NAML]

How much weight did [you / she] [OS56=GAINED: gain / OS56=LOST: lose]?

- ENTER weight in **POUNDS**
- Or PRESS [Enter] to continue to next screen for kilograms

[ENTER] 1 – 900 DK/RF

↓

GO TO OS58CKPT

OS57KILO. [FU Member: [CYAQRTH], [CYNAMF CYNAML], Age: [AGEIWDATE] [(Respondent)]
 Child [1-8]: [J31 J31NAMM J31NAML]]
 (How much weight did [you / she] [gain / lose]?)
 • ENTER number of KILOGRAMS

0.5 – 408.2

Biological Newborn-Parents' Pregnancy Intention

OS58CKPT. CAI Checkpoint: Whether R Is Parent of Newborn

1. R=Parent (RESPAQSN=MOMAQSN or DADAQSN)	5. All Others	→ GO TO OS64CKPT
↓		

About Birth Mother

OS58. [FU Member: [CYAQRTH], [CYNAMF CYNAML], Age: [AGEIWDATE] [(Respondent)]

Child [1-8]: [J31 J31NAMM J31NAML]

Just before [you / [MOTHER] / [J31]'s ([J31NAML]) [and [J31]'s ([J31NAML])...] mother] became pregnant with [J31] ([J31NAML]) [and [J31] ([J31NAML]) ...], did [you / she] use any methods to keep from getting pregnant?

- Methods to keep from getting pregnant include abstinence, withdrawal, rhythm, natural family planning methods, and the pill.
- See [F1] help screen listing many possible birth control methods. Read methods to respondent only as necessary.

1. Yes 5. No 7. Never used any methods to prevent pregnancy (IF VOL) → GO TO OS60CKPT DK/RF

↓

↓

OS59. [FU Member: [CYAQRTH], [CYNAMF CYNAML], Age: [AGEIWDATE] [(Respondent)]

Child [1-8]: [J31 J31NAMM J31NAML]

Had [you / [MOTHER] / [J31]'s ([J31NAML]) [and [J31]'s ([J31NAML])...] mother] stopped all methods before [you / she] became pregnant?

1. Yes 5. No 7. Never used any methods to prevent pregnancy (IF VOL)

OS60CKPT. CAI Checkpoint: Whether Mother Did Not Use or Stopped Contraception Before Pregnancy

1. Stopped Contraception ((OS58=Yes & OS59=Yes) or (OS58=No, DK/RF & OS59=Yes, No, DK/RF))	5. All Others	GO TO OS35
↓		

About Birth Mother

OS60. [FU Member: [CYAQRTH], [CYNAMF CYNAML], Age: [AGEIWDATE] [(Respondent)]

Child [1-8]: [J31 J31NAMM J31NAML]

Was the reason [you / [MOTHER] / [J31]'s ([J31NAML]) [and [J31]'s ([J31NAML])...] mother] [OS59=YES: stopped / ALL OTHERS: [were / was] not] using any methods because [you / [MOTHER] / [J31]'s ([J31NAML]) [and [J31]'s ([J31NAML])...] mother] wanted to become pregnant?

1. Yes 5. No

About R & Other Birth Parent

OS35. [FU Member: [CYAQRTH], [CYNAMF CYNAML], Age: [AGEIWDATE] [(Respondent)]

Child [1-8]: [J31 J31NAMM J31NAML]

Did you or [OTHPARENT=1-24: [FATHER] / OTHPARENT=95, 96, DK/RF: [J31]'s ([J31NAML]) [and [J31]'s ([J31NAML])...] father / OTHPARENT=1-50, 97: [MOTHER] / OTHPARENT=51-70, 95, 96, DK/RF: [J31]'s ([J31NAML]) [and [J31]'s ([J31NAML])...] mother] ever go to a doctor or other medical care provider to talk about ways to help [you / her] become pregnant with [J31]([J31NAML]) [and [J31] ([J31NAML])...]?

 1. Yes 5. No

OS62CKPT. CAI Checkpoint: Whether R Is Mother of Newborn

<input type="checkbox"/> 1. R=Mother (RESPAQSN=MOMAQSN)	<input type="checkbox"/> 5. All Others	→ GO TO OS63CKPT
↓		

About Birth Mother if R=Birth Mother

OS62. [FU Member: [CYAQRTH], [CYNAMF CYNAML], Age: [AGEIWDATE] [(Respondent)]

Child [1-8]: [J31 J31NAMM J31NAML]

Just before you became pregnant (with [J31] ([J31NAML]) [and [J31] ([J31NAML])...]), did you yourself want to have a baby?

 1. Yes → GO TO OS63CKPT 5. No DK/RF → GO TO OS63CKPT

↓

OS62A. [FU Member: [CYAQRTH], [CYNAMF CYNAML], Age: [AGEIWDATE] [(Respondent)]

Child [1-8]: [J31 J31NAMM J31NAML]

Did you want a baby but not at that time, or did you want none or no more at all?

 1. Not at that time 2. None or no more at all 3. Didn't matter (IF VOL)

GO TO OS63CKPT

OS63CKPT. CAI Checkpoint: Whether R is Father of Newborn

<input type="checkbox"/> 1. R=Father (RESPAQSN=DADAQSN)	<input type="checkbox"/> 5. All Others	→ GO TO NEWBORN END RULE
↓		

About Birth Father if R=Birth Father

OS63. [FU Member: [CYAQRTH], [CYNAMF CYNAML], Age: [AGEIWDATE] [(Respondent)]

Child [1-8]: [J31 J31NAMM J31NAML]

Just before [OTHPARENT=1-50, 97: [MOTHER] / OTHPARENT=51-70, 95, 96, DK/RF: [J31]'s ([J31NAML]) [and [J31]'s ([J31NAML])...] mother]] became pregnant (with [J31] ([J31NAML]) [and [J31] ([J31NAML])...]), did you want to have a child?

 1. Yes → GO TO NEWBORN END RULE 5. No DK/RF → GO TO NEWBORN END RULE

↓

OS63A. [FU Member: [CYAQRTH], [CYNAMF CYNAML], Age: [AGEIWDATE] [(Respondent)]

Child [1-8]: [J31 J31NAMM J31NAML]

Did you want to have a child but not at that time, or did you want to have none or no more at all?

 1. Not at that time 2. None or no more at all 3. Didn't matter (IF VOL)
END NEWBORNNOTADP

NEWBORN END Rule: Whether More Children at J31

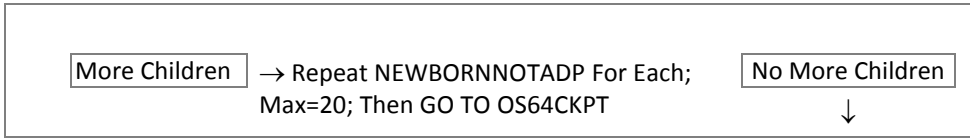

Biological Newborn-R’s Future Pregnancy Intention

OS64CKPT. CAI Checkpoint: Whether R is Parent of Any Newborn for This FU Member

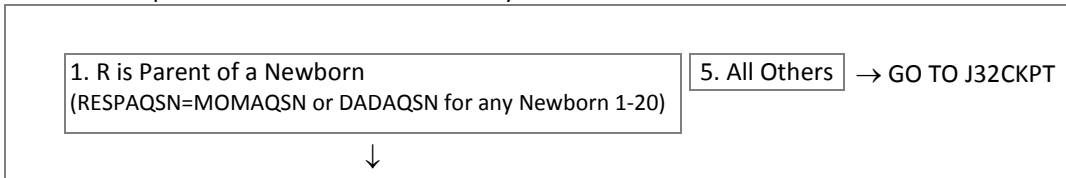

SECTION_J [1-24].PREGINTENTION [1-24]=AQSN of FU Member

RAQSN. AQSN of Respondent

JAQSN. AQSN of Section J FU Member

About R

OS64. **FU Member:** [CYAQRTH], [CYNAMF CYNAML], Age: [AGEIWDATE] [(Respondent)]

Looking to the future, do you yourself want another [R=MOTHER: baby / R=FATHER: child] at some time?

- **IF needed:** Other than your children already born

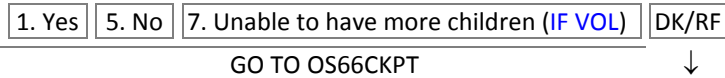

OS65. **FU Member:** [CYAQRTH], [CYNAMF CYNAML], Age: [AGEIWDATE] [(Respondent)]

Do you think you probably want or probably do not want to have another [R=MOTHER: baby / R=FATHER: child] at some time in the future?

- **If R insists:** Don’t know/not sure

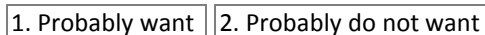

OS66CKPT. CAI Checkpoint: Whether R Has Spouse/Partner/Boyfriend/Girlfriend in FU, or R=Married OFUM

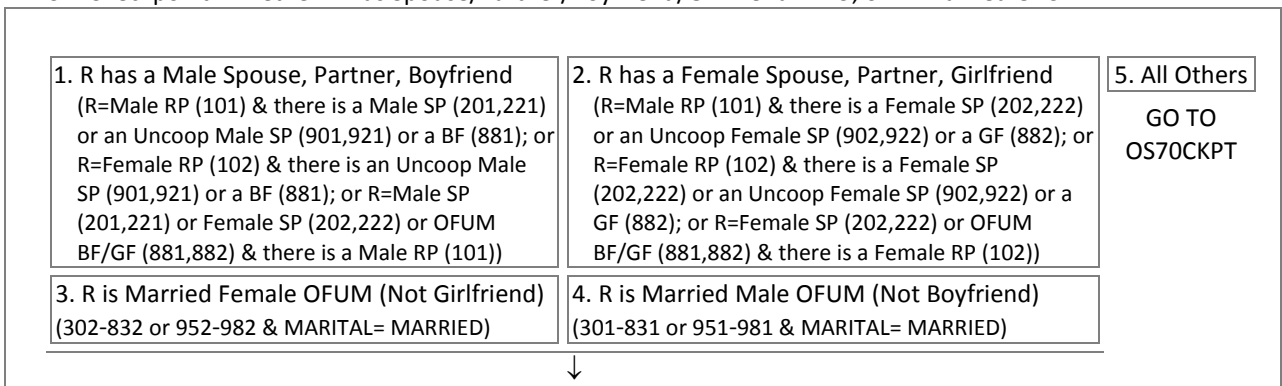

About R's Spouse/Partner, Boyfriend, Girlfriend

OS66. FU Member: [CYAQRTH], [CYNAMF CYNAML], Age: [AGEIWDATE] [(Respondent)]

[R=RP, SP, BF, GF: Spouse or romantic partner of FU member: ^CYAQRTH, ^CYNAMF ^CYNAML, Age: ^AGEIWDATE]
 Looking to the future, does [R=RP, SP, BF, GF: [[CYNAMF] ([CYNAML])] / R=ALL OTHER OFUMs: your spouse] want a [OS66CKPT=1, 3: child / OS66CKPT=2, 4: baby] or another [child / baby] at some time? Would you say definitely yes, probably yes, probably no or definitely no?

1. Definitely yes 2. Probably yes 3. Probably no 4. Definitely no

OS70CKPT. CAI Checkpoint: Whether Parent (and SP/BF/GF) Want More Children

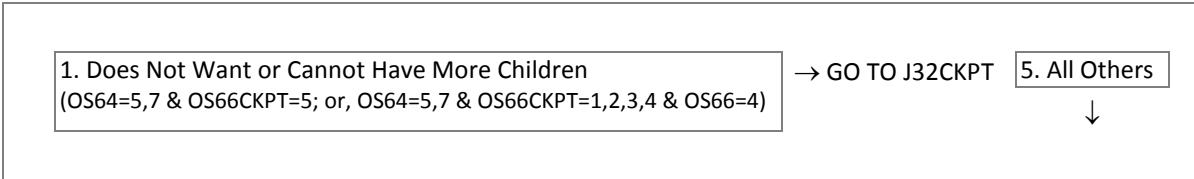

About R (and SP/BF/GF)

OS70. FU Member: [CYAQRTH], [CYNAMF CYNAML], Age: [AGEIWDATE] [(Respondent)]

[R=RP, SP, BF, GF: Spouse or romantic partner of FU member: ^CYAQRTH, ^CYNAMF ^CYNAML, Age: ^AGEIWDATE]
 Sometimes what people want and what they intend are different because they are not able to do what they want. The next question is about your [R=RP, SP, BF, GF: and [CYNAMF] ([CYNAML])]'s / R=ALL OTHER OFUMs: and your spouse's] intentions for a [R=MOTHER: baby / R=FATHER: child] in the future.

Altogether, how many more [babies / children] do you [and [CYNAMF] ([CYNAML])] / and your spouse] intend to have?

- ENTER number of [babies / children]
- ENTER [95] for "None"
- Do not probe DK
- Includes current pregnancy
- Does not include intended adoptions or stepchildren
- If needed: "Intend" refers to what you [and [CYNAMF] ([CYNAML])] / and your spouse] are actually going to try to do

- 1 - 94 95. None

END PREGINTENTION

Adoptive Children

J32CKPT. CAI Checkpoint: J1Ckpt



J33. FU Member: [CYAQRTH], [CYNAMF CYNAML], Age: [AGEIWDATE] [(Respondent)]

TYPE A: [Have you or [RP / Has [RP] or [SP]] legally adopted any children since January [P2YEAR]?

TYPE B: [Has [RP / SP]] legally adopted any children since January [P2YEAR]?

1. Yes 5. No → GO TO J1 END RULE

↓

J34. FU Member: [CYAQRTH], [CYNAMF CYNAML], Age: [AGEIWDATE] [(Respondent)]

[Have you / Has [RP / SP]] ever legally adopted any children?

1. Yes 5. No → GO TO J1 END RULE

↓

J35. FU Member: [CYAQRTH], [CYNAMF CYNAML], Age: [AGEIWDATE] [(Respondent)]
 [TYPE A, B: How many is that? / TYPE C: How many altogether?]

1 – 20

SECTION_J [1-24].J36NAME [1-20] [1-24]=AQS of FU Member; [1-20]=Which child

J36. FU Member: [CYAQRTH], [CYNAMF CYNAML], Age: [AGEIWDATE] [(Respondent)]
 What is the [first / next] child’s name, including middle and last names?

- ENTER First Name
- Ctrl-D and Ctrl-R not allowed; For DK/RF, type [DK] or [RF]

String 25

J36NAMM. FU Member: [CYAQRTH], [CYNAMF CYNAML], Age: [AGEIWDATE] [(Respondent)]
 (What is the [first / next] child’s name, including middle and last names?)

- ENTER Middle Name
- Ask for Middle Name but do not probe DK or RF
- If none, PRESS [Enter] to continue
- Ctrl-D and Ctrl-R not allowed; For DK/RF, PRESS [Enter] to continue

String 25

J36NAML. FU Member: [CYAQRTH], [CYNAMF CYNAML], Age: [AGEIWDATE] [(Respondent)]
 (What is the [first / next] child’s name, including middle and last names?)

- ENTER Last Name
- Ctrl-D and Ctrl-R not allowed; For DK/RF, type [DK] or [RF]

String 25

END J36NAME

AS1 Rule: Number of Children at J35

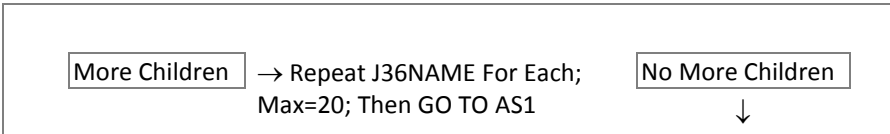

SECTION_J [1-24].AS1_AS9 [1-15] [1-24]=AQS of FU Member; [1-15]=Which child

AS1. FU Member: [CYAQRTH], [CYNAMF CYNAML], Age: [AGEIWDATE] [(Respondent)]
 Child: [J36 J36NAMM J36NAML]

Let’s talk about [J36] [(J36NAML)]. (We can’t always tell from a name. Is that a male or a female?)

1. Male Female

AS2MO. FU Member: [CYAQRTH], [CYNAMF CYNAML], Age: [AGEIWDATE] [(Respondent)]

Child: [J36 J36NAMM J36NAML]

What is [J36]’s [(J36NAML)] full birthdate?

- SELECT Month
- IF NECESSARY: What would be your best estimate?

1. January	2. February	3. March	4. April	5. May	6. June
7. July	8. August	9. September	10. October	11. November	12. December
21. Winter	22. Spring	23. Summer	24. Fall		

AS2DY. FU Member: [CYAQRTH], [CYNAMF CYNAML], Age: [AGEIWDATE] [(Respondent)]

Child: [J36 J36NAMM J36NAML]

(What is [J36]'s [(J36NAML)] full birthdate?)

The month entered is: [AS2MO]

- ENTER day

1 – 31

AS2YR. FU Member: [CYAQRTH], [CYNAMF CYNAML], Age: [AGEIWDATE] [(Respondent)]

Child: [J36 J36NAMM J36NAML]

The month entered is: [AS2MO]

(What is [J36]'s [(J36NAML)] full birthdate?)

- ENTER the year below

1901 – [CYEAR] Actual year

9996 [P2YEAR] – [CYEAR], DK which year

9997 Before [P2YEAR], DK exact year

1901 – [P3YEAR]	[P2YEAR] – [CYEAR]	9996. [P2YEAR] – [CYEAR], DK Which Year	9997. Before [P2YEAR], DK Exact Year
-----------------	--------------------	--	---

AS3. FU Member: [CYAQRTH], [CYNAMF CYNAML], Age: [AGEIWDATE] [(Respondent)]

Child: [J36 J36NAMM J36NAML]

What was [his / her] relationship to [TYPE A: [you and [RP / SP] / [RP] and [SP]] / TYPE B, C: [you / [RP / SP]]] before the adoption?

96. None			
301. Son	302. Daughter	331. Stepson	332. Stepdaughter
381. Foster son	382. Foster daughter	401. Brother	402. Sister
471. Brother-in-law	472. Sister-in-law	481. Brother of Partner/Boyfriend/Girlfriend	
482. Sister of Partner/Boyfriend/Girlfriend		601. Grandson	602. Granddaughter
651. Great-grandson	652. Great-granddaughter	701. Nephew of Reference Person	
702. Niece of Reference Person		711. Nephew of Spouse	712. Niece of Spouse
740. Cousin of Reference Person		750. Cousin of Spouse	
831. Son of Boyfriend/Girlfriend		832. Daughter of Boyfriend/Girlfriend	
950. Relative of Reference Person		960. Relative of Spouse	
970. Relative of Partner/Boyfriend/Girlfriend			

AS4TOWN. FU Member: [CYAQRTH], [CYNAMF CYNAML], Age: [AGEIWDATE] [(Respondent)]

Child: [J36 J36NAMM J36NAML]

In what city and state was [he / she] born?

- ENTER City and go to next screen for State
- For Don't Know, ENTER [Ctrl D]
- For Refusal, ENTER [Ctrl R]

String 25

AS4STATE. FU Member: [CYAQRTH], [CYNAMF CYNAML], Age: [AGEIWDATE] [(Respondent)]

Child: [J36 J36NAMM J36NAML]

(What is the State?)

[AS4TOWN]

- Start typing the name of the State to bring up the look-up list
- For foreign country birth, ENTER [FOR] to select "Foreign Country" from the state list State

String 30; U.S State → GO TO AS5 Foreign Country DK/RF → GO TO AS5



AS4COUNTRY. FU Member: [CYAQRTH], [CYNAMF CYNAML], Age: [AGEIWDATE] [(Respondent)]

Child: [J36 J36NAMM J36NAML]

What is the Country?

[AS4TOWN], [AS4STATE]

- Start typing the name of the Foreign Country to bring up the look-up list

String 25; Country

AS5. FU Member: [CYAQRTH], [CYNAMF CYNAML], Age: [AGEIWDATE] [(Respondent)]

Child: [J36 J36NAMM J36NAML]

Is [J36] [(J36NAML)] living with you now, away with [his / her] [J2 IS FEMALE: father / J2 IS MALE: mother], with some other relative, (has he/she set up a separate household), or what?

1. Living in FU now	2. Living with father elsewhere	
3. Living with mother elsewhere	4. Living with other relative elsewhere	
5. Set up a separate household		6. Deceased
7. Other-specify (AS5SPEC. Specify (STRING 100))		DK/RF



GO TO AS7

AS6MO. FU Member: [CYAQRTH], [CYNAMF CYNAML], Age: [AGEIWDATE] [(Respondent)]

Child: [J36 J36NAMM J36NAML]

In what month and year did [he / she] die?

- SELECT Month and [Enter] to go to next screen for year
- IF NECESSARY: What would be your best estimate?

1. January	2. February	3. March	4. April	5. May	6. June
7. July	8. August	9. September	10. October	11. November	12. December
21. Winter	22. Spring	23. Summer	24. Fall		

AS6YR. FU Member: [CYAQRTH], [CYNAMF CYNAML], Age: [AGEIWDATE] [(Respondent)]

Child: [J36 J36NAMM J36NAML]

The month entered is: [AS6MO]

- ENTER the year below
- 1901 – [CYEAR] Actual year
- 9996 [P2YEAR] – [CYEAR], DK which year
- 9997 Before [P2YEAR], DK exact year

1901 – [P3YEAR]	[P2YEAR] – [CYEAR]	9996. [P2YEAR] – [CYEAR], DK Which Year	9997. Before [P2YEAR], DK Exact Year
-----------------	--------------------	--	---

GO TO AS10 RULE

AS7. FU Member: [CYAQRTH], [CYNAMF CYNAML], Age: [AGEIWDATE] [(Respondent)]

Child: [J36 J36NAMM J36NAML]

Is [he / she] Spanish, Hispanic, or Latino? That is, Mexican, Mexican American, Chicano, Puerto Rican, Cuban, or other Spanish?

0. Not Spanish/Hispanic	1. Mexican	2. Mexican American	3. Chicano
4. Puerto Rican	5. Cuban	7. Other-specify (AS7SPEC. Specify (STRING 100))	

AS8. FU Member: [CYAQRTH], [CYNAMF CYNAML], Age: [AGEIWDATE] [(Respondent)]

Child: [J36 J36NAMM J36NAML]

What is [his / her] race? Is [he / she] white, black, American Indian, Alaska Native, Asian, Native Hawaiian, or Pacific Islander?

- ENTER all that apply
- PROBE: Any others?

1. White	2. Black, African-American, or Negro	
3. American Indian or Alaska Native	5. Native Hawaiian	6. Pacific Islander
7. Other-specify (AS8SPEC. Specify (STRING 100))	DK/RF	4. Asian

GO TO AS10 RULE



AS8A. FU Member: [CYAQRTH], [CYNAMF CYNAML], Age: [AGEIWDATE] [(Respondent)]

Child: [J36 J36NAMM J36NAML]

Would that be Chinese, Filipino, Asian Indian, or what?

1. Chinese	2. Filipino	3. Asian Indian	4. Japanese	5. Korean	6. Vietnamese
7. Other Asian-specify (AS8ASPEC. Specify (STRING 100))					

END AS1_AS9

AS10 Rule: Whether More Children at J36

More Children	→ Repeat AS1_AS9; Max=20; Then GO TO J1 END RULE	No More Children
		↓

J1 End Rule: Whether More Eligible FU Members

More FU Members	→ Repeat SECTION J; Max=24; Then GO TO SECTION KL	No More FU Members	→ GO TO SECTION KL
-----------------	--	--------------------	--------------------

END SECTION_J

Section KL: New RP/SP Background; Returning RP/SP Education

[TOC](#)

SECTION_KL

KL1CKPT [1-2]. CAI Checkpoint: Whether New or Returning Spouse/Partner or Reference Person in FU [1]=SP, [2]=RP

New Spouse/Partner or Reference Person		Returning Spouse/Partner or Reference Person	
<p>1. Spouse/Partner</p> <p>a. Preloaded SP needs KL re-asked (IWTYPE=REINT, RECON & CYFUHU=FU, CYAQRTH=201-222, PYAQRTH=101-222, KLTYPE=LONG)</p> <p>b. New SP preloaded as OFUM (IWTYPE=REINT, RECON & CYFUHU=FU, CYAQRTH=201-222, PYAQRTH<>101-222)</p> <p>c. New SP moved-in (IWTYPE=REINT, RECON & CYFUHU=FUMI, CYAQRTH=201-222)</p> <p>d. New interview (IWTYPE=SO, REC SO, IMMIG, RECLONG & CYFUHU=FU, FUMI, CYAQRTH=201-222)</p>	<p>2. Reference Person</p> <p>a. Preloaded RP needs KL re-asked (IWTYPE=REINT, RECON & CYFUHU=FU, CYAQRTH=101-102, PYAQRTH=101-222, KLTYPE=LONG)</p> <p>b. New RP preloaded as OFUM (IWTYPE=REINT, RECON & CYFUHU=FU, CYAQRTH=101-102, PYAQRTH<>101-222)</p> <p>c. New RP moved-in (IWTYPE=REINT, RECON & CYFUHU=FUMI, CYAQRTH=101-102)</p> <p>d. New interview (IWTYPE=SO, REC SO, IMMIG, RECLONG & CYFUHU=FU, FUMI, CYAQRTH=101-102)</p>	<p>3. Spouse/Partner</p> <p>Preloaded SP does not need KL re-asked (IWTYPE=REINT, RECON & CYFUHU=FU, CYAQRTH=201-222, PYAQRTH=101-222, KLTYPE=SHORT)</p>	<p>4. Reference Person</p> <p>Preloaded RP does not need KL re-asked (IWTYPE=REINT, RECON & CYFUHU=FU, CYAQRTH=101-102, PYAQRTH=101-222, KLTYPE=SHORT)</p>
<p>↓</p> <p>GO TO KL68A</p>			

SECTION_KL.KL [1-2] [1]=Current Spouse/Partner, [2]=Current Reference Person

LINENUM. AQSN of Current Spouse/Partner (Reference Person)

Father - New Spouse/Partner or Reference Person

KL2CITY. [CYAQRTH], [CYNAMF CYNAML]

Now I have some questions about [your / [SP / RP]'s] family and past experiences. Where was [your / her / his] father born?

- ACCEPT Father substitute
- For Don't Know, ENTER [Ctrl D]
- For Refusal, ENTER [Ctrl R]

String 25

KL2STATE. [CYAQRTH], [CYNAMF CYNAML]

(What State is that in?)

[KL2CITY]

- Start typing the name of the State to bring up the look-up list
- IF foreign country, ENTER [FOR] to select "Foreign Country"

String 30; U.S. State → GO TO KL3CITY Foreign Country DK/RF → GO KL3CITY

↓

KL2COUNTRY. [CYAQRTH], [CYNAMF CYNAML]

(What Country is that in?)
[KL2CITY], [KL2STATE]

- Start typing the name of the Foreign Country to bring up the look-up list

String 25; Country

KL3CITY. [CYAQRTH], [CYNAMF CYNAML]

Where did [your / her / his] father grow up?

- Most of the years from ages 6 to 16
- For Don't Know, ENTER [Ctrl D]
- For Refusal, ENTER [Ctrl R]

String 25

KL3STATE. [CYAQRTH], [CYNAMF CYNAML]

(What State is that in?)
[KL3CITY]

- Start typing the name of the State to bring up the look-up list
- IF foreign country, ENTER [FOR] to select "Foreign Country"

String 30; U.S. State → GO TO KL4 Foreign Country DK/RF → GO KL4



KL3COUNTRY. [CYAQRTH], [CYNAMF CYNAML]

(What Country is that in?)
[KL3CITY], [KL3STATE]

- Start typing the name of the Foreign Country to bring up the look-up list

String 25; Country

KL4. [CYAQRTH], [CYNAMF CYNAML]

Where did [your / her / his] father receive his education - in the United States, outside the United States, or both?

1. United States only 2. Outside U.S. only 3. Both in U.S. and outside DK 5. Had no education RF



GO TO KL7CKPT



GO TO KL10

KL5. [CYAQRTH], [CYNAMF CYNAML]

How much education did [your / her / his] father complete (in the United States)?

1. 0 - 5 grades 2. 6 - 8 grades; "Grade School" 3. 9 - 11 grades; "Junior High"

GO TO KL6 4. 12 grades; "High School" 5. 12 grades plus non-academic training

6. 13 - 14 years; Some college; Associate's Degree

7. 15 - 16 years; College; Bachelor's Degree

8. 17 or more years; College; Graduate work; Ph.D, Professional degree DK RF

GO TO KL7CKPT



GO TO KL6

KL5 SIGNAL. What is your best estimate, would you say...

- READ code list below

1. 0 - 5 grades,	2. 6 - 8 grades,	3. 9 - 11 grades,	4. 12 grades,
↓	5. 12 grades plus non-academic training,		
6. 13 - 14 years or an Associate's Degree,			
7. 15 - 16 years or a Bachelor's Degree, or			
8. 17 or more years - a graduate degree, Ph.D, or professional degree?			
DK/RF			

GO TO KL7CKPT

KL6. [CYAQRTH], [CYNAMF CYNAML]

Could he read and write (in English)?

1. Yes	5. No
--------	-------

KL7CKPT. CAI Checkpoint: Whether Father Educated Outside U.S.

1. Outside U.S. (KL4=2, 3)	5. All Others (KL4=1, 5, DK/RF)	→ GO TO KL10
↓		

KL8. [CYAQRTH], [CYNAMF CYNAML]

How many years of school did he complete outside of the U.S.?

1 - 25

KL9. [CYAQRTH], [CYNAMF CYNAML]

What was the highest degree or certificate he earned outside the U.S.?

String 100

KL10. [CYAQRTH], [CYNAMF CYNAML]

What was [your / her / his] father's usual occupation when [you were / [she / he] was] growing up? What kind of work did he do? What were his most important activities or duties?

- DO NOT PROBE

String 500

KL11. [CYAQRTH], [CYNAMF CYNAML]

What kind of business or industry was that in?

- DO NOT PROBE

String 500

Mother - New Spouse/Partner or Reference Person

KL12CITY. [CYAQRTH], [CYNAMF CYNAML]

These next questions are about [your / [SP / RP]'s] mother. Where was [your / her / his] mother born?

- ACCEPT Mother substitute
- For Don't Know, ENTER [Ctrl D]
- For Refusal, ENTER [Ctrl R]

String 25

KL12STATE. [CYAQRTH], [CYNAMF CYNAML]

(What State is that in?)

[KL12CITY]

- Start typing the name of the State to bring up the look-up list
- IF foreign country, ENTER [FOR] to select "Foreign Country"

String 30; U.S. State → GO TO KL13CITY Foreign Country DK/RF → GO KL13CITY



KL12COUNTRY. [CYAQRTH], [CYNAMF CYNAML]

(What Country is that in?)

[KL12CITY, KL12STATE]

- Start typing the name of the Foreign Country to bring up the look-up list

String 25; Country

KL13CITY. [CYAQRTH], [CYNAMF CYNAML]

Where did [your / her / his] mother grow up?

- Most of the years from ages 6 to 16
- For Don't Know, ENTER [Ctrl D]
- For Refusal, ENTER [Ctrl R]

String 25

KL13STATE. [CYAQRTH], [CYNAMF CYNAML]

(What State is that in?)

[KL13CITY]

- Start typing the name of the State to bring up the look-up list
- IF foreign country, ENTER [FOR] to select "Foreign Country"

String 30; U.S. State → GO TO KL14 Foreign Country DK/RF → GO KL14



KL13COUNTRY. [CYAQRTH], [CYNAMF CYNAML]

(What Country is that in?)

[KL13CITY, KL13STATE]

- Start typing the name of the Foreign Country to bring up the look-up list

String 25; Country

KL14. [CYAQRTH], [CYNAMF CYNAML]

Where did [your / her / his] mother receive his education - in the United States, outside the United States, or both?

1. United States only 2. Outside U.S. only 3. Both in U.S. and outside DK 5. Had no education RF



GO TO KL17CKPT



GO TO KL20

KL15. [CYAQRTH], [CYNAMF CYNAML]

How much education did [your / her / his] mother complete (in the United States)?

1. 0 - 5 grades 2. 6 - 8 grades; "Grade School" 3. 9 - 11 grades; "Junior High"

GO TO KL16

4. 12 grades; "High School" 5. 12 grades plus non-academic training

6. 13 - 14 years; Some college; Associate's Degree

7. 15 - 16 years; College; Bachelor's Degree

8. 17 or more years; College; Graduate work; Ph.D, Professional degree

DK

RF

GO TO KL17CKPT



GO TO KL16

KL15 SIGNAL. What is your best estimate, would you say...

- Read code list below

1. 0 - 5 grades,	2. 6 - 8 grades,	3. 9 - 11 grades,	4. 12 grades,
↓	5. 12 grades plus non-academic training,		
6. 13 - 14 years or an Associate's Degree,			
7. 15 - 16 years or a Bachelor's Degree, or			
8. 17 or more years - a graduate degree, Ph.D, or professional degree?			

DK/RF

GO TO KL17CKPT

KL16. [CYAQRTH], [CYNAMF CYNAML]

Could she read and write (in English)?

1. Yes 5. No

KL17CKPT. CAI Checkpoint: Whether Mother Educated Outside U.S.

1. Outside U.S. (KL14=2, 3)	5. All Others (KL14=1, 5, DK/RF)	→ GO TO KL20
↓		

KL18. [CYAQRTH], [CYNAMF CYNAML]

How many years of school did she complete outside of the U.S.?

1 - 25

KL19. [CYAQRTH], [CYNAMF CYNAML]

What was the highest degree or certificate she earned outside the U.S.?

String 100

KL20. [CYAQRTH], [CYNAMF CYNAML]

What was [your / her / his] mother's usual occupation when [you were / [she / he] was] growing up? What kind of work did she do? What were her most important activities or duties?

- DO NOT PROBE

String 500

KL21. [CYAQRTH], [CYNAMF CYNAML]

What kind of business or industry was that in?

- DO NOT PROBE

String 500

Siblings - New Spouse/Partner or Reference Person

KL22. [CYAQRTH], [CYNAMF CYNAML]

Now I have some questions about brothers and sisters. Did [you / [SP / RP]] have any brothers?

- INCLUDE natural siblings only

1. Yes 5. No → GO TO KL28

↓

KL23. [CYAQRTH], [CYNAMF CYNAML]
How many brothers was that?



KL24. [CYAQRTH], [CYNAMF CYNAML]
Is [he / her / his] brother still living?

KL25. [CYAQRTH], [CYNAMF CYNAML]
[Is / Was] he older than [you / [SP / RP]]?

→ GO TO KL28



KL26. [CYAQRTH], [CYNAMF CYNAML]
How many of them are still living?

KL27. [CYAQRTH], [CYNAMF CYNAML]
[Are / Were] any of [your / her / his] brothers older than [you are / [she / he] is]?

KL28. [CYAQRTH], [CYNAMF CYNAML]
Did [you / [SP / RP]] have any sisters?

- INCLUDE natural siblings only

→ GO TO KL33CITY



KL29. [CYAQRTH], [CYNAMF CYNAML]
How many sisters was that?



KL30. [CYAQRTH], [CYNAMF CYNAML]
Is [she / her / his] sister still living?

KL31. [CYAQRTH], [CYNAMF CYNAML]
[Is / Was] she older than [you / [SP / RP]]?

→ GO TO KL33CITY



KL32. [CYAQRTH], [CYNAMF CYNAML]
How many of them are still living?

KL33. [CYAQRTH], [CYNAMF CYNAML]
[Are / Were] any of [your / her / his] sisters older than [you are [she / he] is]?

Birthplace - New Spouse/Partner or Reference Person

KL33CITY. [CYAQRTH], [CYNAMF CYNAML]

[RETURNING SP/RP: Now I have some questions about [your / [SP / RP]'s] family and past experiences.]

In what city and state [were you / was [SP / RP]] born?

- For Don't Know, ENTER [Ctrl D]
- For Refusal, ENTER [Ctrl R]

KL33STATE. [CYAQRTH], [CYNAMF CYNAML]

(What State is that in?)

[KL33CITY]

- Start typing the name of the State to bring up the look-up list
- IF foreign country, ENTER [FOR] to select "Foreign Country"

String 30; U.S. State → GO TO KL34

Foreign Country DK/RF

SIGNAL for US STATE & IMM16IND=1-4: IWER: You entered that this FU member was born in the United States, but she/he was screened during the 2016 New Immigrant Screener as an immigrant who was born outside of the U.S. Please verify.



KL33COUNTRY. [CYAQRTH], [CYNAMF CYNAML]

(What Country is that?)

[KL33CITY, KL33STATE]

- Start typing the name of the Foreign Country to bring up the look-up list

String 25; Country

KL33YEAR. [CYAQRTH], [CYNAMF CYNAML]

In what year did [you / she / he] come to live in the United States?

[KL33CITY, KL33COUNTRY]

- ENTER Year
- ENTER [9997] if not living in the United States
- If needed, PROBE for the **most recent time** [SP / RP] came to live in the U.S.

1901 – [CYEAR] 9997. Not living in United States

SIGNAL for 1901-1997 & IMM16IND=1-4: IWER: You entered that this FU member came to live in the United States before 1998, but she/he was screened during the 2016 New Immigrant Screener as an immigrant who was not in the U.S. in 1997. Please verify.

SIGNAL for 1997 & IMM16IND=1-4: IWER: You entered that this FU member is not living in the United States, but she/he was screened during the 2016 New Immigrant Screener as an immigrant who was currently living in the U.S. Please verify.

KL34. [CYAQRTH], [CYNAMF CYNAML]

Did [you / [SP / RP]] grow up on a farm, in a small town, in a large city, or what?

1. Farm; country 2. Small town; suburb 3. Large city 4. Other-specify (KL34SPEC. Specify (String 100))

KL35STATE. [CYAQRTH], [CYNAMF CYNAML]

In what State (of the U.S.) was that?

- Start typing the name of the State to bring up the look-up list
- IF foreign country, ENTER [FOR] to select "Foreign Country"

String 30; U.S. State

Foreign Country DK/RF



KL35COUNTRY. [CYAQRTH], [CYNAMF CYNAML]

Can you tell me what County that was?

- For Don't Know, ENTER [Ctrl D]
- For Refusal, ENTER [Ctrl R]

String 25 GO TO KL36 DK/RF



KL35CITY. [CYAQRTH], [CYNAMF CYNAML]

What was the name of the nearest town or city?

- For Don't Know, ENTER [Ctrl D]
- For Refusal, ENTER [Ctrl R]

String 25

KL35COUNTRY. [CYAQRTH], [CYNAMF CYNAML]

In what Country was that?

- Start typing the name of the Foreign Country to bring up the look-up list

String 25; Country

KL36. [CYAQRTH], [CYNAMF CYNAML]

[Have you / Has [SP / RP]] lived in any other states or countries besides where [you are / [she / he] is] currently living and where [you / she / he] grew up, including time spent abroad while in the armed forces?

- "LIVED IN" means stayed at least 3 months

1. Yes 5. No

KL37. [CYAQRTH], [CYNAMF CYNAML]

Were [your / [SP / RP]'s] parents poor when [you were / [she / he] was] growing up, pretty well off, or what?

1. Poor 3. Average; it varied 5. Pretty well off

KL38. [CYAQRTH], [CYNAMF CYNAML]

[Were you / Was [she / he]] living with both [your / her / his] natural parents most of the time until [you were / [she / he] was] age 16?

1. Yes 5. No

Race and Ethnicity - New Spouse/Partner or Reference Person

KL39. [CYAQRTH], [CYNAMF CYNAML]

In order to get an idea of the different races and ethnic groups that participate in the study, I would like to ask you about [your / [SP / RP]'s] background. [Are you / Is [she / he]] Spanish, Hispanic, or Latino? That is, Mexican, Mexican American, Chicano, Puerto Rican, Cuban, or other Spanish?

0. Not Spanish/Hispanic 1. Mexican 2. Mexican American 3. Chicano
4. Puerto Rican 5. Cuban 7. Other-specify (KL39SPEC. Specify (STRING 100))

KL40. [CYAQRTH], [CYNAMF CYNAML]

What is [your / her / his] race? [Are you / Is [she / he]] white, black, American Indian, Alaska Native, Asian, Native Hawaiian, or Pacific Islander?

- ENTER all that apply
- PROBE: Any others?

1. White 2. Black, African-American, or Negro
3. American Indian or Alaska Native 5. Native Hawaiian 6. Pacific Islander
7. Other-specify (KL40SPEC. Specify (STRING 100)) DK/RF 4. Asian

GO TO KL41



KL40A. [CYAQRTH], [CYNAMF CYNAML]

Would that be Chinese, Filipino, Asian Indian, or what?

1. Chinese	2. Filipino	3. Asian Indian	4. Japanese	5. Korean	6. Vietnamese
7. Other Asian-specify (KL40ASPEC. Specify (STRING 100))					

KL41. [CYAQRTH], [CYNAMF CYNAML]

What is [your / her / his] ancestry or ethnic origin? From what country or part of the world did [your / her / his] ancestors come from?

- PROBE: Is there a second? (What is it?)
- IF R reports a State in the U.S., ENTER [America]

String 200

Military Service - New Spouse/Partner or Reference Person

KL42. [CYAQRTH], [CYNAMF CYNAML]

[Have you / Has [she / he]] ever been in the United States military service?

1. Yes	5. No
--------	-------

Education - New Spouse/Partner or Reference Person

KL43. [CYAQRTH], [CYNAMF CYNAML]

Where did [you / [SP / RP]] receive [your / her / his] education — in the United States, outside the United States, or both?

1. United States	2. Outside U.S. only	3. Both in U.S. and outside	DK	5. Had no education	RF
↓	GO TO KL59CKPT	↓		GO TO KL59CKPT	

KL44. [CYAQRTH], [CYNAMF CYNAML]

Now I would like to talk about the education [you have / [she / he] has] received. Did [you / she / he] graduate from high school, get a GED, or neither?

- ENTER [3] if R says still in school (attending grade 1-12) or working on a GED

1. Graduated from high school	2. Got a GED	3. Neither	DK/RF
↓	GO TO KL46	GO TO KL49	GO TO KL51

KL45MO. [CYAQRTH], [CYNAMF CYNAML]

In what month and year did [you / she / he] graduate?

- SELECT Month and [Enter] to go to next screen for year
- IF NECESSARY: What would be your best estimate?

1. January	2. February	3. March	4. April	5. May	6. June
7. July	8. August	9. September	10. October	11. November	12. December
21. Winter	22. Spring	23. Summer	24. Fall		

KL45YR. [CYAQRTH], [CYNAMF CYNAML]

The month entered is: [KL45MO]

- ENTER the year below

1920 – [CYEAR] → GO TO KL51

KL46. [CYAQRTH], [CYNAMF CYNAML]

How many grades of regular school did [you / she / he] finish prior to getting [your / her / his] GED?

- Record last grade finished prior to receiving GED
- If needed: Regular school includes high school and schooling that leads to a college or professional school degree.

0. None	1. First grade	2. Second grade	3. Third grade
GO TO	4. Fourth grade	5. Fifth grade	6. Sixth grade
KL48MO	7. Seventh grade	8. Eighth grade	9. Ninth grade
	10. Tenth grade	11. Eleventh grade	DK/RF → GO TO KL48MO



KL47MO. [CYAQRTH], [CYNAMF CYNAML]

In what month and year did [you / she / he] last attend [KL46]?

- SELECT Month and [Enter] to go to next screen for year
- IF NECESSARY: What would be your best estimate?

1. January	2. February	3. March	4. April	5. May	6. June
7. July	8. August	9. September	10. October	11. November	12. December
21. Winter	22. Spring	23. Summer	24. Fall		

KL47YR. [CYAQRTH], [CYNAMF CYNAML]

The month entered is: [KL47MO]

- ENTER the year below

1920 – [CYEAR]

KL48MO. [CYAQRTH], [CYNAMF CYNAML]

In what month and year did [you / she / he] receive [your / her / his] GED?

- SELECT Month and [Enter] to go to next screen for year
- IF NECESSARY: What would be your best estimate?

1. January	2. February	3. March	4. April	5. May	6. June
7. July	8. August	9. September	10. October	11. November	12. December
21. Winter	22. Spring	23. Summer	24. Fall		

KL48YR. [CYAQRTH], [CYNAMF CYNAML]

The month entered is: [KL48MO]

- ENTER the year below

1920 – [CYEAR] → GO TO KL51

KL49. [CYAQRTH], [CYNAMF CYNAML]

How many grades of regular school did [you / she / he] finish?

- Record last grade finished
- If needed: Regular school includes high school and schooling that leads to a college or professional school degree.

0. None	1. First grade	2. Second grade	3. Third grade	4. Fourth grade
GO TO	5. Fifth grade	6. Sixth grade	7. Seventh grade	8. Eighth grade
KL51	9. Ninth grade	10. Tenth grade	11. Eleventh grade	DK/RF → GO TO KL51



KL50MO. [CYAQRTH], [CYNAMF CYNAML]

In month and what year did [you / she / he] last attend [KL49]?

- SELECT Month and [Enter] to go to next screen for year
- IF NECESSARY: What would be your best estimate?

1. January	2. February	3. March	4. April	5. May	6. June
7. July	8. August	9. September	10. October	11. November	12. December
21. Winter	22. Spring	23. Summer	24. Fall		

KL50YR. [CYAQRTH], [CYNAMF CYNAML]

The month entered is: [KL50MO]

- ENTER the year below

1920 – [CYEAR]

KL51. [CYAQRTH], [CYNAMF CYNAML]

Did [you / she / he] attend college?

1. Yes 5. No → GO TO KL59CKPT



KL52MO. [CYAQRTH], [CYNAMF CYNAML]

In what month and year did [you / she / he] last attend college?

- If still in school, ENTER [96] for month
- SELECT Month and [Enter] to go to next screen for year
- IF NECESSARY: What would be your best estimate?

1. January	2. February	3. March	4. April	5. May	6. June	
7. July	8. August	9. September	10. October	11. November	12. December	96. Still in school
21. Winter	22. Spring	23. Summer	24. Fall	DK/RF		



GO TO KL53

KL52YR. [CYAQRTH], [CYNAMF CYNAML]

The month entered is: [KL52MO]

- ENTER the year below
- 9996 If still in school

1920 – [CYEAR] 9996. Still in school

KL53. [CYAQRTH], [CYNAMF CYNAML]

What is the highest year of college [you have / [she / he] has] completed?

- IF R gives a degree: How many years of college [have you / has [she / he]] completed? We'll talk about any college degrees [you have / [she / he] has] earned next.

0. Less than one year	1. One year	2. Two years	3. Three years
GO TO KL59CKPT	4. Four years	5. Five years or more	DK/RF



KL54. [CYAQRTH], [CYNAMF CYNAML]

Did [you / she / he] receive a college degree?

1. Yes 5. No → GO TO KL59CKPT



KL55. [CYAQRTH], [CYNAMF CYNAML]

What is the highest college degree [you have / [she / he] has] received?

- PROBE for the **highest degree received**

1. Associate's degree/AA	3. Master's degree/MA/MS/MBA
2. Bachelor's degree/BA/BS	4. Doctorate/PhD
	5. LLB, JD (Law degrees)
	6. MD, DDS, DVM, DO (Medical degrees)
	8. Honorary degree
	97. Other-specify (KL55SPEC. Specify (String 100))
DK/RF	

GO TO KL55E



KL55A. [CYAQRTH], [CYNAMF CYNAML]

What was [your / her / his] major or majors at the college or university from which [you / she / he] received [your / her / his] bachelor's degree?

- Probe for details and dual majors

String 100

KL55B. [CYAQRTH], [CYNAMF CYNAML]

What was the name of the college or university (from which [you / she / he] received [your / her / his] bachelor's degree)?

String 100

KL55CCITY. [CYAQRTH], [CYNAMF CYNAML]

Where was it located?

- If needed: In what city and state was the college or university from which [you / she / he] received [your / her / his] bachelor's degree?

String 100

KL55CSTATE. [CYAQRTH], [CYNAMF CYNAML]

(Where was it located?)

- If needed: In what state was the college or university from which [you / she / he] received [your / her / his] bachelor's degree?
- Start typing the name of the State to bring up the look-up list
- IF foreign country, ENTER [FOR] to select "Foreign Country"

String 30; U.S. State → GO TO KL55DMO Foreign Country DK/RF → GO TO KL55DMO



KL55CCOUNTRY. [CYAQRTH], [CYNAMF CYNAML]

(Where was it located?)

- If needed: In what country was the college or university from which [you / she / he] received [your / her / his] bachelor's degree?
- Start typing the name of the Foreign Country to bring up the look-up list

String 30; Country

KL55DMO. [CYAQRTH], [CYNAMF CYNAML]

In what month and year did [you / she / he] receive [your / her / his] bachelor's degree?

- **SELECT** Month and [Enter] to go to next screen for year
- **IF NECESSARY:** What would be your best estimate?

1. January	2. February	3. March	4. April
5. May	6. June	7. July	8. August
9. September	10. October	11. November	12. December
21. Winter	22. Spring	23. Summer	24. Fall

KL55DYR. [CYAQRTH], [CYNAMF CYNAML]

(In what month and year did [you / she / he] receive [your / her / his] bachelor's degree?

The month entered is: [KL55DMO]

- **ENTER** the year below

1920 – [CYEAR]

KL55E. [CYAQRTH], [CYNAMF CYNAML] [KL55]

(And) What was [your / her / his] [KL55=BACHELORS: major or majors / ALL OTHERS: area of study] at the college or university from which [you / she / he] received [your / her / his] highest degree?

- **Probe for details and dual majors**

String 100

KL56. [CYAQRTH], [CYNAMF CYNAML] [KL55]

What was the name of the college or university?

- **If needed:** What was the name of the college or university from which [you / she / he] received [your / her / his] highest degree?

String 100

KL57CITY. [CYAQRTH], [CYNAMF CYNAML] [KL55]

Where was it located?

- **If needed:** In what city and state was the college or university from which [you / she / he] received [your / her / his] highest degree?

String 100

KL57STATE. [CYAQRTH], [CYNAMF CYNAML] [KL55]

(Where was it located?)

- **If needed:** In what state was the college or university from which [you / she / he] received [your / her / his] highest degree?
- **Start typing the name of the State to bring up the look-up list**
- **IF foreign country, ENTER [FOR] to select "Foreign Country"**

String 30; U.S. State → GO TO KL58MO Foreign Country DK/RF → GO TO KL58MO



KL57COUNTRY. [CYAQRTH], [CYNAMF CYNAML] [KL55]

(Where was it located?)

- **If needed:** In what country was the college or university from which [you / she / he] received [your / her / his] highest degree?
- **Start typing the name of the Foreign Country to bring up the look-up list**

String 30: Country

KL58MO. [CYAQRTH, CYNAMF CYNAML] [KL55]

In what month and year did [you / she / he] receive [your / her / his] highest degree?

- **SELECT Month and [Enter] to go to next screen for year**
- **IF NECESSARY:** What would be your best estimate?

1. January	2. February	3. March	4. April	5. May	6. June
7. July	8. August	9. September	10. October	11. November	12. December
21. Winter	22. Spring	23. Summer	24. Fall		

KL58YR. [CYAQRTH, CYNAMF CYNAML] [KL55]

The month entered is: [KL58MO]

- **ENTER the year below**

1920 – [CYEAR]

KL59CKPT. CAI Checkpoint: Where Educated

1. Outside U.S. (KL43=2, 3)	3. U.S. Only (KL43=1, DK)	5. All Others (KL43=5, RF)	→ GO TO KL62
↓	GO TO KL61ACKPT		

KL60. [CYAQRTH], [CYNAMF CYNAML]

How many years of school did [you / she / he] complete outside of the U.S.?

1 – 25

KL61. [CYAQRTH], [CYNAMF CYNAML]

What was the highest degree or certificate [you / she / he] earned outside the U.S.?

String 100

KL61ACKPT. CAI Checkpoint: Whether Still in School

1. Still in School (KL52MO=96 or KL52YR=9996)	→ GO TO KL61B	5. All Others
		↓

KL61A. [CYAQRTH], [CYNAMF CYNAML]

[Are you / Is [she / he]] currently attending or enrolled in regular school? Regular school includes high school and schooling that leads to a college or professional school degree.

1. Yes 5. No → GO TO KL62

↓

KL61B. [CYAQRTH], [CYNAMF CYNAML]

[KL61ACKPT=STILL IN SCHOOL: Earlier you said [you are / [SP / RP] is] still in school.]
What grade or year [are you / is [she / he]] currently attending?

1. First grade	2. Second grade	3. Third grade	4. Fourth grade	5. Fifth grade
6. Sixth grade	7. Seventh grade	8. Eighth grade	9. Ninth grade	10. Tenth grade
11. Eleventh grade		12. Twelfth grade, "High School", GED		
13. 1st year college (freshman)		14. 2nd year college (sophomore)		
15. 3rd year college (junior)		16. 4th year college (senior)		
17. 5th year or higher of college		18. Post-graduate work		

KL62. [CYAQRTH], [CYNAMF CYNAML]

Did [you / she / he] receive any other degree or a certificate through a vocational school, a training school, or an apprenticeship program?

- IWER: This includes vocational training received in the military and military occupational specialties (MOS)

1. Yes 5. No → GO TO KL68A



SECTION_KL.KL [1-2].KL63_KL67 [1-5] [1]=Current Spouse/Partner, [2]=Current Reference Person; [1-5]=Which cert

KL63. [CYAQRTH], [CYNAMF CYNAML]

What type of degree or certificate was that?

1. Degree	2. Certificate	3. License	4. Diploma (not High School)
7. Other-specify (KL63SPEC. Specify (String 100))			

KL64. [CYAQRTH], [CYNAMF CYNAML]

In what field was that?

String 100

KL65. [CYAQRTH], [CYNAMF CYNAML]

From what type of institution or organization was that?

1. Vocational/Trade school	2. Community/Junior college
3. Business/Secretarial school	4. Armed Forces
5. High school	6. Hospital/Health Care facility or school
7. Cosmetology/Beauty/Barber school	8. Police/Firefighter training program
9. Job training through government; except code 8	10. Training by private employer
11. Religious Institution or Bible College/School	97. Other-specify (KL65SPEC. Specify (String 100))

KL66MO. [CYAQRTH], [CYNAMF CYNAML]

In what month and year did [you / she / he] receive that degree or certificate?

- SELECT Month and [Enter] to go to next screen for year
- IF NECESSARY: What would be your best estimate?

1. January	2. February	3. March	4. April	5. May	6. June
7. July	8. August	9. September	10. October	11. November	12. December
21. Winter	22. Spring	23. Summer	24. Fall		

KL66YR. [CYAQRTH], [CYNAMF CYNAML]
 The month entered is: [KL66MO]
 • ENTER the year below

1920 – [CYEAR]

KL67. [CYAQRTH], [CYNAMF CYNAML]

Did [you / she / he] receive any other training degree or certificate?

- This includes vocational training received in the military and military occupational specialties (MOS)

1. Yes → Repeat KL63_KL67; MAX=5; 5. No

Then GO TO KL68



END KL63_KL67

Religious Preference - New Spouse/Partner or Reference Person

KL68A. [CYAQRTH], [CYNAMF CYNAML]

We'd like to ask you some questions about religious or spiritual beliefs. What is [your / [SP / RP]'s] religious preference?

- IF R says Christian, PROBE for specific denomination; if R cannot provide specific denomination ENTER [14]
- IF R says Protestant, PROBE for specific denomination; if R cannot provide specific denomination, ENTER [13]

1. None/No preference	2. Atheist (do not believe in God)	3. Agnostic (not sure if there is a God)
4. Roman Catholic	5. Greek/Russian/Eastern Orthodox	6. Baptist
7. Episcopalian	8. Jehovah's Witness	9. Lutheran
10. Methodist/ African Methodist	11. Pentecostal/ Assembly of God	12. Presbyterian
13. Protestant, Unspecified	14. Christian, Unspecified	15. Christian, Non-denominational
16. Jewish (Judaism)	17. Muslim (Islam)	18. Buddhist
97. Other-Specify (KL68APEC. Specify (String 100))		

KL68ACKPT. CAI Checkpoint: Whether New or Returning Spouse/Partner or Reference Person in FU (SEE KL1CKPT)

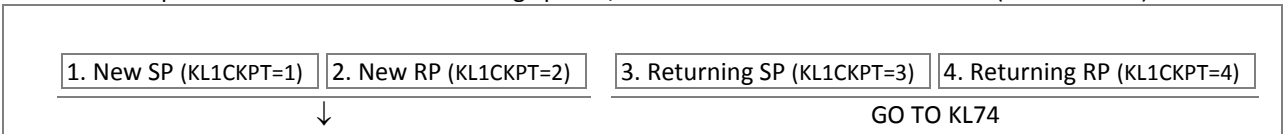

Years Working - New Spouse/Partner or Reference Person

KL70 Rule: Whether 18 Years Old or Older

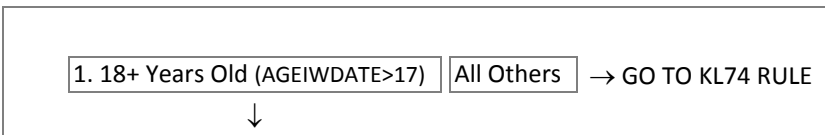

KL70. [CYAQRTH], [CYNAMF CYNAML]

How many years altogether [have you / has [she / he]] worked for money since [you were / [she / he] was] 18?

- FOR none, ENTER [0]
- [AGE 19+: FOR 1 year or less, ENTER [1]]
- [AGE 18: For less than 1 year, ENTER [95]]
- FOR all years since 18, ENTER [96]

[0] → GO TO KL74 RULE [AGE 19+: 1 – [AGEIWDATE minus 18]]
 [AGE 18: 95. Less than one year] 96. All years since 18 DK/RF



KL71. [CYAQRTH], [CYNAMF CYNAML]

How many of these years did [you / she / he] work full-time for most or all of the year?

- FOR none, ENTER [0]
- [AGE 19+: FOR 1 year or less, ENTER [1]]
- [AGE 18: For less than 1 year, ENTER [95]]
- [KL70=96: FOR all years since 18, ENTER [96]]

[0] → GO TO KL74 RULE [AGE 19+: 1 – [AGEIWDATE minus 18]]
 [AGE 18: 95. Less than one year] [KL70=96: 96. All years since 18] DK/RF



KL72. [CYAQRTH], [CYNAMF CYNAML]

Thinking of [your / her / his] first full-time regular job, what kind of work did [you / she / he] do?
 What were [your / her / his] most important activities or duties?

- DO NOT PROBE
- To SAVE your entry, use Alt-S

Open End

KL73. [CYAQRTH], [CYNAMF CYNAML]

What kind of business or industry was that in?

- DO NOT PROBE
- To SAVE your entry, use Alt-S

Open End

KL74 Rule: Whether New Spouse/Partner (Reference Person) (SEE KL1CKPT)

New SP (KL1CKPT=1) → Repeat SECTION KL For RP New RP (KL1CKPT=2) → GO TO MMIGRANT SECTION

Education Update - Returning Spouse/Partner or Reference Person

KL74. [CYAQRTH], [CYNAMF CYNAML]

Now I would like to talk about the education [you have / [SP / RP] has] received.

[Have you / Has [SP / RP]] attended regular school since our last interview on [PYIWDATE]? Regular school includes high school and schooling that leads to a college or professional school degree.

- ENTER [2] for “still in school”

1. Yes 2. Still in school (IF VOL) 5. No DK/RF

GO TO KL74C

GO TO KL84CKPT

KL74C. [CYAQRTH], [CYNAMF CYNAML]

Since our last interview on [PYIWDATE], where did [you / [SP / RP]] receive [your / her / his] education — in the United States, outside the United States, or both?

1. United States only	2. Outside U.S. only	3. Both in U.S. and outside	DK	RF	→ GO TO KL83ACKPT
↓	GO TO KL83ACKPT		↓		

SECTION_KL.KL [1-2].KL76_KL83 [1]=Current Spouse/Partner, [2]=Current Reference Person

KL76CKPT. CAI Checkpoint: Whether Preloaded Education Level is Less Than HS Grad/GED or Non-Response

1. <HS Grad/GED (PYPERSINFO.COMPEDUC=0-11, NA)	5. All Others	→ GO TO KL78B
↓		

KL76. [CYAQRTH], [CYNAMF CYNAML]

[COMPEDUC=0-11: (Since our last interview on [PYIWDATE],) did / COMPEDUC=NA: Did] [you / she / he] graduate from high school, get a GED, or neither?

- ENTER [3] if R says still in school (attending grade 1-12) or working on a GED

1. Graduated from high school	2. Got a GED	3. Neither	DK/RF	→ GO TO KL78B
↓	GO TO KL77A	GO TO KL78A		

KL77MO. [CYAQRTH], [CYNAMF CYNAML]

In what month and year did [you / she / he] graduate?

- [COMPEDUC=0-11: If needed: Between our last interview on [PYIWDATE] and now]
- SELECT Month and [Enter] to go to next screen for year
- If necessary: What would be your best estimate?

1. January	2. February	3. March	4. April	5. May	6. June
7. July	8. August	9. September	10. October	11. November	12. December
21. Winter	22. Spring	23. Summer	24. Fall		

KL77YR. [CYAQRTH], [CYNAMF CYNAML]

(In what month and year did [you / she / he] graduate?)

- [COMPEDUC=0-11: If needed: Between our last interview on [PYIWDATE] and now]
- The month entered is: [KL77MO]
- ENTER the year below

1920 – [CYEAR]	→ GO TO KL78B
----------------	---------------

CHECK for KL77YR<P2YEAR & COMPEDUC=0-11: IWER: All years prior to [P2YEAR] are not allowed since we are asking about education since [PYIWDATE]. Please VERIFY Year graduated High School since [PYIWDATE]: If R confirms the year is before [P2YEAR], then select GOTO and ENTER [5] at KL74. If R gives a year from [P2YEAR] to [CYEAR], then CLOSE and ENTER [Year] at this question.

KL77A. [CYAQRTH], [CYNAMF CYNAML]

How many grades of regular school did [you / she / he] finish prior to getting [your / her / his] GED?

- Record last grade finished prior to receiving GED
- If needed: Regular school includes high school and schooling that leads to a college or professional school degree.

0. None	1. First grade	2. Second grade	3. Third grade
GO TO	4. Fourth grade	5. Fifth grade	6. Sixth grade
KL78MO	7. Seventh grade	8. Eighth grade	9. Ninth grade
	10. Tenth grade	11. Eleventh grade	DK/RF → GO TO KL78MO



KL77AMO. [CYAQRTH], [CYNAMF CYNAML]

In what month and year did [you / she / he] last attend [KL77A]?

- SELECT Month and [Enter] to go to next screen for year
- IF NECESSARY: What would be your best estimate?

1. January	2. February	3. March	4. April	5. May	6. June
7. July	8. August	9. September	10. October	11. November	12. December
21. Winter	22. Spring	23. Summer	24. Fall		

KL77AYR. [CYAQRTH], [CYNAMF CYNAML]

(In what month and year did [you / she / he] last attend [KL77A]?)

The month entered is: [KL77AMO]

- ENTER the year below

1920 – [CYEAR]

KL78MO. [CYAQRTH], [CYNAMF CYNAML]

In what month and year did [you / she / he] receive [your / her / his] GED?

- [COMPEDUC=0-11: If needed: Between our last interview on [PYIWDATE] and now]
- SELECT Month and [Enter] to go to next screen for year
- If necessary: What would be your best estimate?

1. January	2. February	3. March	4. April	5. May	6. June
7. July	8. August	9. September	10. October	11. November	12. December
21. Winter	22. Spring	23. Summer	24. Fall		

KL78YR. [CYAQRTH], [CYNAMF CYNAML]

(In what month and year did [you / she / he] receive [your / her / his] GED?)

- [COMPEDUC=0-11: If needed: Between our last interview on [PYIWDATE] and now]
- The month entered is: [KL78MO]
- ENTER the year below

1920 – [CYEAR] → GO TO KL78B

CHECK for KL78YR<P2YEAR & COMPEDUC=0-11: IWER: All years prior to [P2YEAR] are not allowed since we are asking about education since [PYIWDATE]. Please VERIFY Year received GED since [PYIWDATE]: If R confirms the year is before [P2YEAR], then select GOTO and ENTER [5] at KL74. If R gives a year from [P2YEAR] to [CYEAR], then CLOSE and ENTER [Year] at this question.

KL78A. [CYAQRTH], [CYNAMF CYNAML]

How many grades of regular school did [you / she / he] finish?

- Record last grade finished
- If needed: Regular school includes high school and schooling that leads to a college or professional school degree.

0. None	1. First grade	2. Second grade	3. Third grade
GO TO KL78B	4. Fourth grade	5. Fifth grade	6. Sixth grade
	7. Seventh grade	8. Eighth grade	9. Ninth grade
	10. Tenth grade	11. Eleventh grade	DK/RF → GO TO KL78B



KL78AMO. [CYAQRTH], [CYNAMF CYNAML]

In what month and what year did [you / she / he] last attend [KL78A]?

- SELECT Month and [Enter] to go to next screen for year
- IF NECESSARY: What would be your best estimate?

1. January	2. February	3. March	4. April	5. May	6. June
7. July	8. August	9. September	10. October	11. November	12. December
21. Winter	22. Spring	23. Summer	24. Fall		

KL78AYR. [CYAQRTH], [CYNAMF CYNAML]

(In what month and what year did [you / she / he] last attend [KL78A]?)

The month entered is: [KL78AMO]

- ENTER the year below

1920 – [CYEAR]

KL78B. [CYAQRTH], [CYNAMF CYNAML]

Did [you / she / he] attend college between [PYIWDATE] and now?

1. Yes	5. No	→ GO TO KL78DCKPT
--------	-------	-------------------



CHECK for KL78B=NO, DK/RF & COMPEDUC=12-17: IWER: R reported that [SP/ RP] attended school since [PYIWDATE], but we know (she / he) already graduated high school or received a GED BEFORE [P2YEAR]. Please VERIFY with R whether this person attended college since [PYIWDATE] or is currently attending college: If R says NO or DK/RF, then select GOTO and ENTER [5] or [DK, RF] at KL74. If R says YES, then CLOSE here and ENTER [1] at this question.

KL78BMO. [CYAQRTH], [CYNAMF CYNAML]

In what month and year did [you / she / he] last attend college?

- If needed: Between our last interview on [PYIWDATE] and now
- If still in school, ENTER [96] for month
- SELECT Month and [Enter] to go to next screen for year
- NECESSARY: What would be your best estimate?

1. January	2. February	3. March	4. April		
5. May	6. June	7. July	8. August		
9. September	10. October	11. November	12. December		
21. Winter	22. Spring	23. Summer	24. Fall	DK/RF	96. Still in school



GO TO KL78DCKPT

KL78BYR. [CYAQRTH], [CYNAMF CYNAML]

(In what month and year did [you / she / he] last attend college?)

- **If needed:** Between our last interview on [PYIWDATE] and now
The month entered is: [KL78BMO]
- ENTER the year below
9996 If still in school

1920 – [CYEAR] 9996. Still in school

CHECK for KL78BYR<P2YEAR: IWER: All years prior to [P2YEAR] are not allowed since we are asking about education since [PYIWDATE]. Please VERIFY Year last attended college since [PYIWDATE]: If R confirms the year is before [P2YEAR], then select GOTO and ENTER [5] at KL78B. If R gives a year from [P2YEAR] to [CYEAR], then CLOSE and ENTER [Year] at this question.

KL78DCKPT. CAI Checkpoint: Whether Attended College since Last Wave

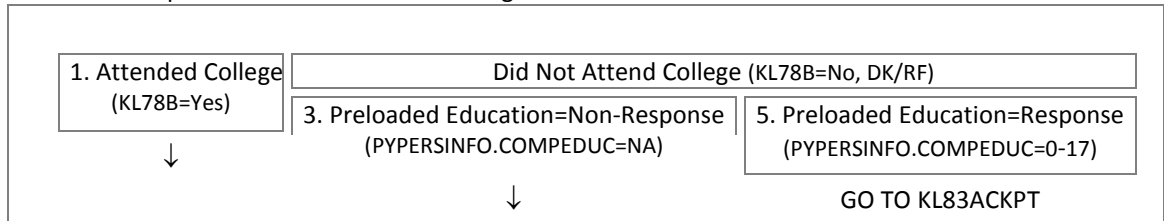

KL78D. [CYAQRTH], [CYNAMF CYNAML]

Altogether, what is the highest year of college [you have / [she / he] has] completed?

- **IF R gives a degree:** How many years of college [have you / has [she / he]] completed altogether? We'll talk about any college degrees [you have / [she / he] has] earned next.
- [KL78DCKPT=3: ENTER [0] if R says None or Never attended college]

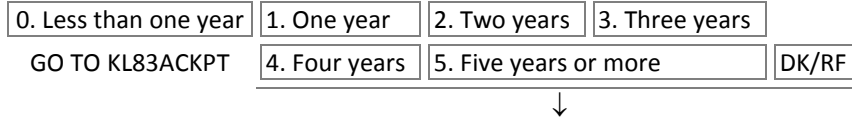

KL78ECKPT. CAI Checkpoint: Whether Attended College since Last Wave

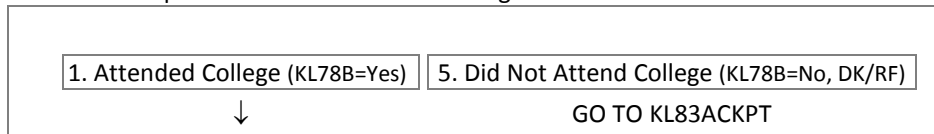

KL78E. [CYAQRTH], [CYNAMF CYNAML]

Did [you / she / he] receive a college degree between [PYIWDATE] and now?

1. Yes 5. No → GO TO KL83ACKPT

↓

KL78F1. [CYAQRTH], [CYNAMF CYNAML]

(Since our last interview on [PYIWDATE],) what college degree did [you / [she / he]] receive?

- **If more than one degree, PROBE for the highest degree received since [PYIWDATE]**

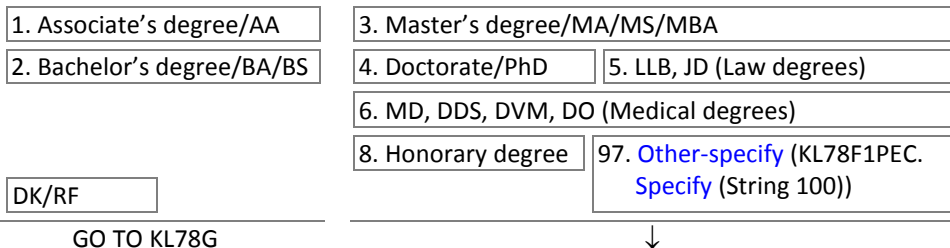

KL78F2. [CYAQRTH], [CYNAMF CYNAML]

What was [your / her / his] major or majors at the college or university from which [you / she / he] received [your / her / his] bachelor's degree?

- Probe for details and dual majors

String 100

KL78F3. [CYAQRTH], [CYNAMF CYNAML]

What was the name of the college or university?

- If needed: What was the name of the college or university from which [you / she / he] received [your / her / his] bachelor's degree?

String 100

KL78F4CITY. [CYAQRTH], [CYNAMF CYNAML]

Where was it located?

- If needed: In what city and state was the college or university from which [you / she / he] received [your / her / his] bachelor's degree?

String 100

KL78F4STATE. [CYAQRTH], [CYNAMF CYNAML]

(Where was it located?)

- If needed: In what state was the college or university from which [you / she / he] received [your / her / his] bachelor's degree?
- Start typing the name of the State to bring up the look-up list
- IF foreign country, ENTER [FOR] to select "Foreign Country"

String 30: U.S. State → GO TO KL78F5MO Foreign Country ↓ DK/RF → GO TO KL78F5MO

KL78F4COUNTRY. [CYAQRTH], [CYNAMF CYNAML]

(Where was it located?)

- If needed: In what country was the college or university from which [you / she / he] received [your / her / his] bachelor's degree?
- Start typing the name of the Foreign Country to bring up the look-up list

String 30; Country

KL78F5MO. [CYAQRTH], [CYNAMF CYNAML]

In what month and year did [you / she / he] receive [your / her / his] bachelor's degree?

- SELECT Month and [Enter] to go to next screen for year
- IF NECESSARY: What would be your best estimate?

1. January	2. February	3. March	4. April
5. May	6. June	7. July	8. August
9. September	10. October	11. November	12. December
21. Winter	22. Spring	23. Summer	24. Fall

KL78F5YR. [CYAQRTH], [CYNAMF CYNAML]

(In what month and year did [you / she / he] receive [your / her / his] bachelor's degree)?

The month entered is: [KL78F5MO]

- ENTER the year below

1920 – [CYEAR]

KL78G. [CYAQRTH], [CYNAMF CYNAML] [KL78F1]

(And) What was [your / her / his] [KL78F1=BACHELORS: major or majors / ALL OTHERS: area of study] at the college or university from which [you / she / he] received [your / her / his] highest degree since our last interview on [PYIWDATE]?

- Probe for details and dual majors

String 100

KL81. [CYAQRTH], [CYNAMF CYNAML] [KL78F1]

What was the name of the college or university?

- If needed: What was the name of the college or university from which [you / she / he] received [your / her / his] highest degree (since our last interview on [PYIWDATE])?

String 100

KL82CITY. [CYAQRTH], [CYNAMF CYNAML] [KL78F1]

Where was it located?

- If needed: In what city and state was the college or university from which [you / she / he] received [your / her / his] highest degree (since our last interview on [PYIWDATE])?

String 25

KL82STATE. [CYAQRTH], [CYNAMF CYNAML] [KL78F1]

(Where was it located?)

- If needed: In what state was the college or university from which [you / she / he] received [your / her / his] highest degree (since our last interview on [PYIWDATE])?
- Start typing the name of the State to bring up the look-up list
- IF foreign country, ENTER [FOR] to select "Foreign Country"

String 30; U.S. State → GO TO KL83MO Foreign Country DK/RF → GO TO KL83MO



KL82COUNTRY. [CYAQRTH], [CYNAMF CYNAML] [KL78F1]

(Where was it located?)

- If needed: (In what country was the college or university from which [you / she / he] received [your / her / his] highest degree (since our last interview on [PYIWDATE])?)
- Start typing the name of the Foreign Country to bring up the look-up list

String 25; Country

KL83MO. [CYAQRTH], [CYNAMF CYNAML] [KL78F1]

In what month and year did [you / she / he] receive [your / her / his] highest degree?

- If needed: Between our last interview on [PYIWDATE] and now
- SELECT Month and [Enter] to go to next screen for year
- If necessary: What would be your best estimate?

1. January	2. February	3. March	4. April	5. May	6. June
7. July	8. August	9. September	10. October	11. November	12. December
21. Winter	22. Spring	23. Summer	24. Fall		

KL83YR. [CYAQRTH], [CYNAMF CYNAML] [KL78F1]

(In what month and year did [you / she / he] receive [your / her / his] highest degree)?

- If needed: Between our last interview on [PYIWDATE] and now
- The month entered is: [KL83MO]
- ENTER the year below

1920 – [CYEAR]

CHECK for KL83YR<P2YEAR: IWER: All years prior to [P2YEAR] are not allowed since we are asking about education since [PYIWDATE]. Please VERIFY Year received highest degree since [PYIWDATE]: If R confirms the year is before [P2YEAR], then select GOTO and ENTER [5] at KL78E. If R gives a year from [P2YEAR] to [CYEAR], then CLOSE and ENTER [Year] at this question.

END KL76_KL83

KL83ACKPT. CAI Checkpoint: Where Educated

1. Outside U.S. (KL74C =2, 3)	3. U.S. Only (KL74C =1, DK)	5. All Others (KL74C=RF) → GO TO KL84 END RULE
↓	GO TO KL84CKPT	

KL83A. [CYAQRTH], [CYNAMF CYNAML]

Between [PYIWDATE] and now, how many years of school did [you / she / he] complete outside of the U.S.?

1 – 25

CHECK for KL83A>3: Number of years should be 1 to 3

KL83B. [CYAQRTH], [CYNAMF CYNAML]

(Between [PYIWDATE] and now,) what was the highest degree or certificate [you / she / he] earned outside the U.S.?

String 100

KL84CKPT. CAI Checkpoint: Whether Still in School

1. Still in School (KL74=2 or KL78BMO=96 or KL78BYR=9996) → GO TO KL84A	5. All Others
	↓

KL84. [CYAQRTH], [CYNAMF CYNAML]

[Are you / Is [she / he]] currently attending or enrolled in regular school? (Regular school includes high school and schooling that leads to a college or professional school degree.)

1. Yes 5. No → GO TO KL84 END RULE

↓

KL84A. [CYAQRTH], [CYNAMF CYNAML]

[KL84CKPT=STILL IN SCHOOL: Earlier you said [you are / [SP / RP] is] still in school.]

What grade or year [are you / is [she / he]] currently attending?

1. First grade	2. Second grade	3. Third grade	4. Fourth grade	5. Fifth grade
6. Sixth grade	7. Seventh grade	8. Eighth grade	9. Ninth grade	10. Tenth grade
11. Eleventh grade		12. Twelfth grade, "High School", GED		
13. 1st year college (freshman)		14. 2nd year college (sophomore)		
15. 3rd year college (junior)		16. 4th year college (senior)		
17. 5th year or higher of college		18. Post-graduate work		

KL84 END Rule: See KL1Ckpt

Returning SP (KL1CKPT=3)

→ Repeat SECTION KL; Then
GO TO IMMIGRANT SECTION

Returning RP (KL1CKPT=4)

GO TO IMMIGRANT SECTION

END KL

END SECTION_KL

Section IMMIG: New Immigrant

[TOC](#)

SECTION_NEWIMMIG

IMMCKPT. CAI Checkpoint: Whether This FU is New Immigrant Sample

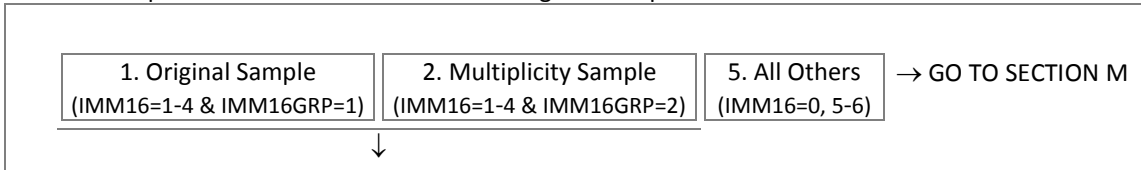

SECTION_NEWIMMIG.NEWIMMDETAIL [1-2] [1]=Current Reference Person, [2]=Current Spouse/Partner

AQSN. AQSN of Current Reference Person (Spouse/Partner)

Language Proficiency - Reference Person and Spouse/Partner

IMM1. [CYNAMF CYNAML]: [CYAQRTH], [CYFUHU], Age [AGEIWDAT]

IF interview conducted in Spanish or other non-English language, DO NOT READ-ENTER [1] to continue

Now I have a few more questions about [your / [RP]'s / [SP]'s] background.

[Have you / Has [RP / SP]] ever spoken any language other than English?

1. Yes → GO TO IMM3 5. No



IMM2. [CYNAMF CYNAML]: [CYAQRTH], [CYFUHU], Age [AGEIWDAT]

IF interview conducted in Spanish or other non-English language, DO NOT READ-ENTER [1] to continue

Is any language other than English spoken in [your / [RP / SP]'s] home?

1. Yes 5. No → GO TO IMM END RULE



IMM3. [CYNAMF CYNAML]: [CYAQRTH], [CYFUHU], Age [AGEIWDAT]

What languages did [you / [RP / SP]] speak in [your / his / her] home with [your / his / her] parents when [you were / [he / she] was] age 10?

- ENTER ALL THAT APPLY

1. English	2. Spanish	3. Arabic	4. Chinese	5. Creole	6. Filipino, Tagalog
7. French	8. Hindi	9. Japanese	10. Kru	11. Korean	12. Portuguese
13. Russian	14. Tamil	15. Telugu	16. Urdu	17. Vietnamese	
97. Other-specify (IMM3SPEC. Specify. (String100))					

IMM4. [CYNAMF CYNAML]: [CYAQRTH], [CYFUHU], Age [AGEIWDAT]

What languages [do you / does [RP / SP]] currently speak at home?

- ENTER all that apply

1. English	2. Spanish	3. Arabic	4. Chinese	5. Creole	6. Filipino, Tagalog
7. French	8. Hindi	9. Japanese	10. Kru	11. Korean	12. Portuguese
13. Russian	14. Tamil	15. Telugu	16. Urdu	17. Vietnamese	
93. [IMM3SPEC]					
97. Other-specify (IMM4SPEC. Specify. (String100))					

IMM5. [CYNAMF CYNAML]: [CYAQRTH], [CYFUHU], Age [AGEIWDATE]

In the past 12 months, while living in the United States, what languages [have you / has [he / she]] spoken outside of home, for example, while at work?

- ENTER ALL THAT APPLY

1. English	2. Spanish	3. Arabic	4. Chinese	5. Creole	6. Filipino, Tagalog
7. French	8. Hindi	9. Japanese	10. Kru	11. Korean	12. Portuguese
13. Russian	14. Tamil	15. Telugu	16. Urdu	17. Vietnamese	
93. [IMM3SPEC]	94. [IMM4SPEC]				
97. Other-specify (IMM5SPEC. Specify. (String100))					

IMM6. [CYNAMF CYNAML]: [CYAQRTH], [CYFUHU], Age [AGEIWDATE]

What languages [do you / does [RP / SP]] speak when [you are / [he / she] is] with friends?

- ENTER all that apply

1. English	2. Spanish	3. Arabic	4. Chinese	5. Creole	6. Filipino, Tagalog
7. French	8. Hindi	9. Japanese	10. Kru	11. Korean	12. Portuguese
13. Russian	14. Tamil	15. Telugu	16. Urdu	17. Vietnamese	
93. [IMM3SPEC]	94. [IMM4SPEC]	95. [IMM5SPEC]			
97. Other-specify (IMM6SPEC. Specify. (String100))					

IMM7CKPT. CAI Checkpoint: Languages Selected at IMM3-IMM6

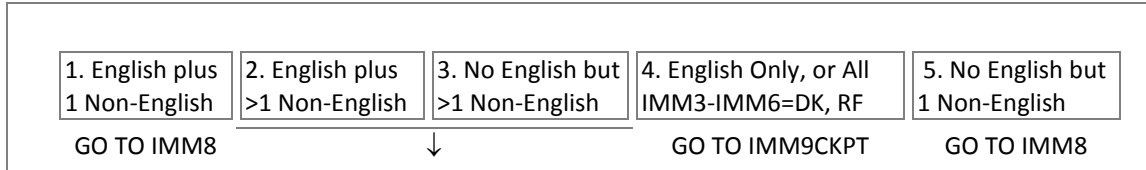

IMM7. [CYNAMF CYNAML]: [CYAQRTH], [CYFUHU], Age [AGEIWDATE]

[ENGLISH ALSO SELECTED: Aside from English, which / ALL OTHERS: Which] of these languages [do you / does [RP / SP]] speak or read most often?

- READ list if needed

Languages Selected at IMM3-IMM6

2. Spanish	3. Arabic			
4. Chinese	5. Creole	6. Filipino, Tagalog	7. French	
8. Hindi	9. Japanese	10. Kru	11. Korean	
12. Portuguese	13. Russian	14. Tamil	15. Telugu	
16. Urdu	17. Vietnamese			
93. [IMM3SPEC]	94. [IMM4SPEC]	95. [IMM5SPEC]	96. [IMM6SPEC]	DK/RF → GO TO IMM9CKPT

↓

IMM8. [CYNAMF CYNAML]: [CYAQRTH], [CYFUHU], Age [AGEIWDATE]

In general, which language [do you / does [he / she]] speak and read more often, English or [IMM7CKPT=2, 3: [IMM7] / IMM7CKPT=1, 5: [IMM3-IMM6 selection]]?

- If needed, PROBE: Is that (English / [[IMM7] / [IMM3-IMM6]]) only or (English / [[IMM7] / [IMM3-IMM6]]) more frequently?

1. English only	2. English more frequently	3. Both languages about equally (VOL)
4. [[IMM7] / [IMM3-IMM6]] more frequently	5. [[IMM7] / [IMM3-IMM6]] only	

IMM9CKPT. CAI Checkpoint: Individual Immigrant Status of Reference Person (Spouse/Partner)

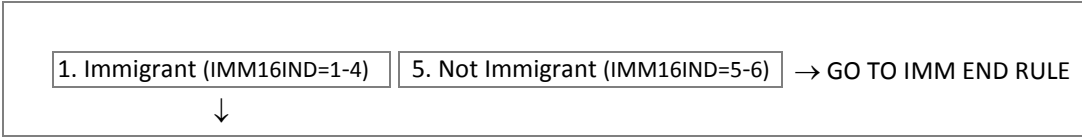

IMM9. [CYNAMF CYNAML]: [CYAQRTH], [CYFUHU], Age [AGEIWDAT]E

How well [do you / does [RP / SP]] understand spoken English? Would you say very well, well, not well, or not at all?

- | | | | |
|--------------|---------|-------------|---------------|
| 1. Very well | 2. Well | 3. Not well | 4. Not at all |
|--------------|---------|-------------|---------------|

IMM10. [CYNAMF CYNAML]: [CYAQRTH], [CYFUHU], Age [AGEIWDAT]E

How well [do you / does [he / she]] speak English? (Would you say very well, well, not well, or not at all?)

- | | | | |
|--------------|---------|-------------|---------------|
| 1. Very well | 2. Well | 3. Not well | 4. Not at all |
|--------------|---------|-------------|---------------|

IMM11. [CYNAMF CYNAML]: [CYAQRTH], [CYFUHU], Age [AGEIWDAT]E

How well [do you / does [he / she]] read English? (Would you say very well, well, not well, or not at all?)

- | | | | |
|--------------|---------|-------------|---------------|
| 1. Very well | 2. Well | 3. Not well | 4. Not at all |
|--------------|---------|-------------|---------------|

IMM12. [CYNAMF CYNAML]: [CYAQRTH], [CYFUHU], Age [AGEIWDAT]E

How well [do you / does [he / she]] write English? (Would you say very well, well, not well, or not at all?)

- | | | | |
|--------------|---------|-------------|---------------|
| 1. Very well | 2. Well | 3. Not well | 4. Not at all |
|--------------|---------|-------------|---------------|

END NEWIMMIGDETAIL

IMM END Rule: Whether Spouse/Partner in FU

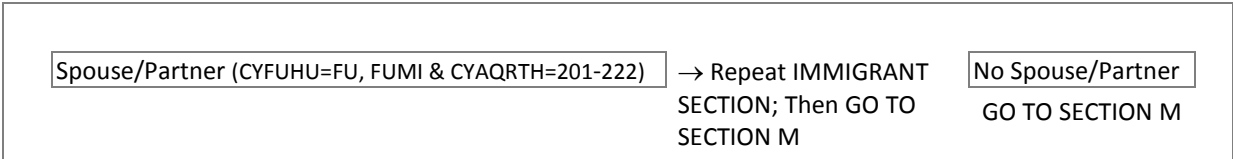

END NEWIMMIG

Section M: Philanthropy

[TOC](#)

SECTION_M

M0 Rule: Who is Respondent

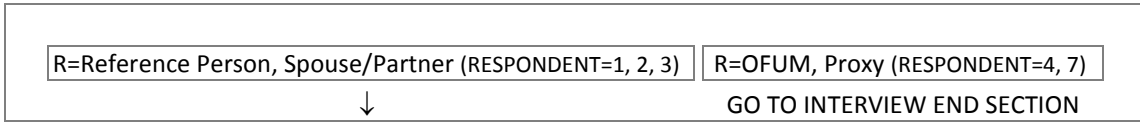

Donations

M1_INTRO. Next, we will be talking about donations to charities that serve a variety of purposes such as religious activity, helping people in need, health care and medical research, education, arts, environment, and international aid. Charitable organizations include religious or non-profit organizations that help those in need or that serve and support the public interest. They range in size from national organizations like the United Way and the American Red Cross down to local community organizations. Political contributions are not included. Donations include money, assets, property or goods, whether made directly to the organization, through payroll deduction, or on the internet.

- [ENTER \[1\] to continue](#)

M1. During [PYEAR], did you [or anyone in your family] donate money, assets, property or goods, with a combined value of more than \$25 to religious or charitable organizations?

→ GO TO M56A

↓

M2. Did you make any donations specifically for religious purposes or spiritual development, for example to a church, synagogue, mosque, TV or radio ministry? Please do not include donations to schools, hospitals, and other charities run by religious organizations. I will be asking you about those donations next.

→ GO TO M3

↓

M2A. How much was that in [PYEAR]? (Altogether, what was the total dollar value of all donations you [and your family] made in [PYEAR] towards religious purposes?)

M3. [*M2=YES*: Not counting the donations you just told me about, (during [PYEAR],) / *ALL OTHERS*: (During [PYEAR],)] did you [or anyone in your family] donate to any organization that served a combination of purposes? For example, the United Way, the United Jewish Appeal, the Catholic Charities, or your local community foundation?

→ GO TO M4

↓

M3A. How much was that (in [PYEAR])? (Altogether, what was the total dollar value of all donations you [and your family] made in [PYEAR] towards combined purpose funds?)

M4. ([M2 OR M3=YES: Not counting the donations you just told me about, did you / ALL OTHERS: Did you] [or anyone in your family] make any donations (during [PYEAR])) to organizations that help people in need of food, shelter, or other basic necessities?

1. Yes 5. No → GO TO M5



M4A. How much was that (in [PYEAR])? (What was the total dollar value of all donations you [and your family] made in [PYEAR] to organizations that help people in need of basic necessities?)

M5. ([ANY M2-M4=YES: Not counting the donations you just told me about, did you / ALL OTHERS: Did you] [or anyone in your family] make donations (during [PYEAR])) to health care or medical research organizations? For example, to hospitals, nursing homes, mental health facilities, cancer, heart and lung associations, or telethons?

1. Yes 5. No → GO TO M6



M5A. How much was that (in [PYEAR])? (What was the total dollar value of all donations you [and your family] made in [PYEAR] towards health care or medical research organizations?)

M6. ([ANY M2-M5=YES: Not counting the donations you just told me about, did you / ALL OTHERS: Did you] [or anyone in your family] make donations (during [PYEAR])) towards educational purposes? For example, to colleges, grade schools, PTAs, libraries, or scholarship funds? Please do not include direct tuition payments for you or other family members.

1. Yes 5. No → GO TO M7



M6A. How much was that (in [PYEAR])? (What was the total dollar value of all donations you [and your family] made in [PYEAR] towards educational purposes?)

M7. ([ANY M2-M6=YES: Not counting the donations you just told me about, (during [PYEAR],) / ALL OTHERS: During [PYEAR],) did you [or anyone in your family] make donations) to organizations that provide youth or family services? Such as to scouting, boys' and girls' clubs, sports leagues, Big Brothers or Sisters, foster care, or family counseling?

1. Yes 5. No → GO TO M8



M7A. How much was that (in [PYEAR])? (What was the total dollar value of all donations you [and your family] made in [PYEAR] towards youth and family services purposes?)

M8. ([ANY M2-M7=YES: Not counting the donations you just told me about, (during [PYEAR],) / ALL OTHERS: (During [PYEAR],) did you [or anyone in your family] make donations) to organizations that support or promote the arts, culture, or ethnic awareness? Such as, to a museum, theatre, orchestra, public broadcasting, or ethnic cultural awareness?

1. Yes 5. No → GO TO M9



M8A. How much was that (in [PYEAR])? (What was the total dollar value of all donations you [and your family] made in [PYEAR] towards the arts, culture, or ethnic awareness?)

M9. ([ANY M2-M8=YES: Not counting the donations you just told me about, (during [PYEAR],) / ALL OTHERS: (During [PYEAR],)] did you [or anyone in your family] make donations) to organizations that improve neighborhoods and communities? Such as, to community associations or service clubs?

1. Yes 5. No → GO TO M10



M9A. How much was that (in [PYEAR])? (What was the total dollar value of all donations you [and your family] made in [PYEAR] towards improving neighborhoods and communities?)

M10. ([ANY M2-M9=YES: Not counting the donations you just told me about, (during [PYEAR],) / ALL OTHERS: (During [PYEAR],)] did you [or anyone in your family] make donations) to organizations that preserve the environment? Such as, for conservation efforts, animal protection, or parks?

1. Yes 5. No → GO TO M11



M10A. How much was that (in [PYEAR])? (What was the total dollar value of all donations you [and your family] made in [PYEAR] towards preserving the environment?)

M11. ([ANY M2-M10=YES: Not counting the donations you just told me about, (during [PYEAR],) / ALL OTHERS: (During [PYEAR],)] did you [or anyone in your family] make donations) to organizations that provide international aid or promote world peace? Such as, international children's funds, disaster relief, or human rights?

1. Yes 5. No → GO TO M12



M11A. How much was that (in [PYEAR])? (What was the total dollar value of all donations you [and your family] made in [PYEAR] towards providing international aid or promoting world peace?)

M12. ([ANY M2-M11=YES: Not counting the donations you just told me about, (during [PYEAR],) / ALL OTHERS: (During [PYEAR],)] did you [or anyone in your family] make donations of) money, assets, or property to charitable organizations with purposes other than those we just talked about?

1. Yes 5. No → GO TO M56A



M12A. What was the main purpose or cause supported by that organization?

- **PROBE:** Please tell me a little more about that. What does this organization do?

M12B. How much was that (in [PYEAR])? (What was the total dollar value of all donations you [and your family] made in [PYEAR] towards (this / these) last purpose(s)?)

Religious Attendance – Reference Person and Spouse/Partner

M56A_AQSN. AQSN of Current Reference Person

M57A_AQSN. AQSN of Current Spouse/Partner

M56A. [CYNAMF CYNAML], [CYAQRTH], [CYFUHU], Age: [AGEIWDATE], [(Respondent)]

And finally, during the year [PYEAR], on average, how often did [you / [RP]] go to religious services?

- ENTER amount here, then ENTER unit of time on next screen (Day, Week, Two weeks, Month, Year)

→ GO TO M57CKPT → GO TO M57CKPT



M56B. [CYNAMF CYNAML], [CYAQRTH], [CYFUHU], Age: [AGEIWDATE], [(Respondent)]

The amount entered is: [M56A] per ____

- SELECT the unit of time below

M57CKPT. CAI Checkpoint: Whether Spouse/Partner in FU

→ GO TO INTERVIEW
END SECTION



M57A. [CYNAMF CYNAML], [CYAQRTH], [CYFUHU], Age: [AGEIWDATE], [(Respondent)]

During the year [PYEAR], on average, how often did [you / [SP]] go to religious services?

- ENTER amount here, then ENTER unit of time on next screen (Day, Week, Two weeks, Month, Year)

→ GO TO INTERVIEW END SECTION → GO TO INTERVIEW END SECTION



M57B. [CYNAMF CYNAML], [CYAQRTH], [CYFUHU], Age: [AGEIWDATE], [(Respondent)]

The amount entered is: [M57A] per ____

- SELECT the unit of time below

END SECTION_M

Interview Close

[TOC](#)

IWCLOSE

WEB3. This last question is about your F.E.S. (Family Economics Study) interview. We plan to offer a web version of F.E.S. in 2021. Would you prefer to complete your F.E.S. interview on your own on the web, or on the telephone with an interviewer?

1. Web or internet (on your own) 2. Telephone (with an interviewer) 3. No preference/either ([IF VOL](#)) DK/RF



GO TO Q1

WEB4. Which device would you most likely use to complete your interview on the web - - a smartphone, tablet, laptop, desktop computer, or something else?

1. Smartphone 2. Tablet 3. Laptop 4. Desktop computer

7. [Other-Specify](#) (WEB4SPEC. [Please specify](#) (String 100))

Q1. Thank you, that concludes the interview portion of my call. Now, I just need to verify some information that will help us contact [you / this family] in the future.

- [ENTER \[1\] to continue](#)

1. Continue → GO TO ADDRPAYMENT SECTION

END IWCLOSE

Address Updates and Payment

[TOC](#)

ADDRPAYMENT

WTRPREPAID. Whether interview was prepaid (WTRPREPAIDLOAD)

tSample_line.vExt_026; initial setting = 5; if payment is prepaid, WtrPrePaidLoad = 1.

AMTPREPAID. Prepayment Amount (AMTPREPAIDLOAD)

tSample_line.vExt_027; initial setting = \$0.00; if payment is prepaid, AmtPrePaidLoad = \$ amount of prepayment.

PAYMENT. Standard Payment Amount (PAYMENTLOAD)

tSample_line.vExt_028; initial setting = \$70.00 for Reinterview and \$100.00 for Recontact, Splitoff, and Immigrant; if standard payment is increased and interview has not progressed to the address/payment section yet, PaymentLoad = new \$ amount of standard payment.

RPAY1. CAI Checkpoint: Who is Respondent

<input type="text" value="1. R=Reference Person, Spouse/Partner, OFUM (RESPONDENT=1-4)"/>	<input type="text" value="2. R=Proxy (RESPONDENT=7)"/>
GO TO RPAY2A	
↓	

Proxy R Contact Information

RPAY1A. You will receive \$[PAYMENT] from The University of Michigan in appreciation of your help. In order for the University to send you a check or other correspondence, I must make sure that I have your correct name and mailing address.

- [ENTER \[1\] to continue](#)

ADDRPAYMENT.PROXYADDR

<p>ADDRTYPE. Which Address</p> <p><input type="text" value="1. Proxy R"/></p> <p>TITLE. Title -- e.g. "Mr", "Mrs", "Ms", "Miss", "Dr" What is your complete name and mailing address?</p> <ul style="list-style-type: none"> • If no title, PRESS [Enter] to continue • Ctrl-D and Ctrl-R not allowed; For DK/RF, PRESS [Enter] to continue <p><input type="text" value="String 6"/></p> <p>NAMF. First Name</p> <ul style="list-style-type: none"> • Ctrl-D and Ctrl-R not allowed; For DK/RF type [DK] or [RF] <p><input type="text" value="String 20"/></p>	<p>ADDR1. Address 1</p> <ul style="list-style-type: none"> • IF R says the mailing address contains both a street address and PO Box: ENTER street address here (Address 1) and ENTER PO Box in Address 2 • Ctrl-D and Ctrl-R not allowed; For DK/RF type [DK] or [RF] <p><input type="text" value="String 40"/></p> <p>APTSTE. Apt/Suite</p> <ul style="list-style-type: none"> • If none, PRESS [Enter] to continue • Ctrl-D and Ctrl-R not allowed; For DK/RF, PRESS [Enter] to continue <p><input type="text" value="String 10"/></p> <p>ADDR2. Address 2</p> <ul style="list-style-type: none"> • IF R says the mailing address contains both a street
---	--

<p>NAMM. Middle Name</p> <ul style="list-style-type: none"> Ask for Middle Name but do not probe DK or RF If none, PRESS [Enter] to continue Ctrl-D and Ctrl-R not allowed; For DK/RF, PRESS [Enter] to continue <p>String 20</p> <p>NAML. Last Name</p> <ul style="list-style-type: none"> Ctrl-D and Ctrl-R not allowed; For DK/RF type [DK] or [RF] <p>String 20</p> <p>SUFFIX. Suffix -- e.g. "Sr", "Jr"</p> <ul style="list-style-type: none"> If none, PRESS [Enter] to continue Ctrl-D and Ctrl-R not allowed; For DK/RF, PRESS [Enter] to continue <p>String 20</p> <p>INCO. In Care Of</p> <p>Is there an "in care of" for this address?</p> <ul style="list-style-type: none"> If none, PRESS [Enter] to continue Ctrl-D and Ctrl-R not allowed; For DK/RF, PRESS [Enter] to continue <p>String 40</p>	<p>address and PO Box: ENTER PO Box here (Address 2)</p> <ul style="list-style-type: none"> If none, PRESS [Enter] to continue Ctrl-D and Ctrl-R not allowed; For DK/RF, PRESS [Enter] to continue <p>String 40</p> <p>CITY. City</p> <ul style="list-style-type: none"> Ctrl-D and Ctrl-R not allowed; For DK/RF type [DK] or [RF] <p>String 40</p> <p>STATE. State</p> <ul style="list-style-type: none"> Start typing the name of the State to bring up the look-up list If foreign country, ENTER [FOR] to select "Foreign Country" <p>String 30; String 4</p> <p>ZIP. Zip Code</p> <ul style="list-style-type: none"> If foreign country, ENTER all [0]'s Ctrl-D and Ctrl-R not allowed; For DK/RF ENTER all [0]'s <p>-----</p> <p>COUNTRY. Country if different from USA</p> <ul style="list-style-type: none"> Start typing the name of the Foreign Country to bring up the look-up list <p>String 30; String 2</p>
--	--

END PROXYADDR**ADDRPAYMENT.PROXYPH**

<p>ADDRTYPE. Which Phone</p> <p>1. Proxy R</p> <p>WTRCELL. Do you have a <u>cell</u> phone?</p> <ul style="list-style-type: none"> Do NOT ask but ENTER [1] if you know R is using a cell phone Ctrl-D and Ctrl-R not allowed; For DK/RF ENTER [5] <p>1. Yes 5. No → GO TO WTRHOME</p> <p>↓</p> <p>CELLPH. Cell Phone - Area Code and Telephone Number</p> <p>What is the area code and phone number?</p> <ul style="list-style-type: none"> If foreign phone, PRESS [ENTER] to go to foreign phone field Ctrl-D and Ctrl-R not allowed; For DK/RF, GO BACK and ENTER [5] at WtrCell <p>[ENTER] (____)____-_____ → GO TO WTRHOME</p> <p>↓</p> <p>CELLFOR. Cell Phone - Foreign Number</p> <p>(What is the area code and phone number?)</p> <ul style="list-style-type: none"> Ctrl-D and Ctrl-R not allowed; For DK/RF, GO BACK and 	<p>WTRHOME. Do you have a <u>home</u> phone?</p> <ul style="list-style-type: none"> Ctrl-D and Ctrl-R not allowed; For DK/RF ENTER [5] <p>1. Yes 5. No → GO TO RPAY1FF</p> <p>↓</p> <p>HOMEPH. Home Phone - Area Code and Telephone Number</p> <p>What is the area code and phone number?</p> <ul style="list-style-type: none"> If foreign phone, PRESS [ENTER] to go to foreign phone field Ctrl-D and Ctrl-R not allowed; For DK/RF, GO BACK and ENTER [5] at WtrHome <p>[ENTER] (____)____-_____ → GO TO RPAY1FF</p> <p>↓</p> <p>HOMEFOR. Home Phone - Foreign Number</p> <p>(What is the area code and phone number?)</p> <ul style="list-style-type: none"> Ctrl-D and Ctrl-R not allowed; For DK/RF, GO BACK and ENTER [5] at WtrHome <p>String 20</p>
--	--

ENTER [5] at WtrCell	
String 20	

END PROXYPH

RPAY1FF. What is your relationship to [REFERENCE PERSON]?

1. Mother	2. Father	3. Son	4. Daughter	5. Sister	6. Brother
7. Aunt	8. Uncle	9. Grandmother	10. Grandfather	11. Friend	12. Father-in-law
13. Mother-in-law	14. Cousin	97. Other-Specify (RPAY1FFSPEC. Specify. (String 50))			

RPAY1G. Is there an email address where we can contact you?

1. Yes 5. No → GO TO RAY2A



RPAY1H. (What is that e-mail address?)

- ENTER email address, then READ BACK and VERIFY with Respondent
- Ctrl-D and Ctrl-R not allowed; For DK/RF go back and ENTER [Ctrl-D, Ctrl-R] at previous question

String 50

FU Member R Mailing Address (or Reference Person, if R=Proxy)

RAY2A. [NOT PREPAID: [R=RP, SP, OFUM: You will receive \$[PAYMENT] from the University of Michigan in appreciation of your help. In order for the University to send you a check or other correspondence, I must make sure that I have your correct name and mailing address. / R=PROXY: I would also like to have the correct name and address for [REFERENCE PERSON].] / R=PROXY: I would also like to have the correct name and address for [REFERENCE PERSON].]]

[R=RP, SP, OFUM: In order for the University to keep in touch with you, I must make sure that I have your correct name and mailing address. / R=PROXY: I would also like to have the correct name and address for [REFERENCE PERSON].]

[PREPAID: This interview was PREPAID

- Verify/Update/Change (R's/Reference Person's) mailing address and phone number
- ENTER [1] to continue

1. Continue

RP2AQSN. AQSN of Respondent (or Reference Person, if R=Proxy)

ADDRPAYMENT.RMAILADDR Name not prefilled; Address prefilled with RespondentAddr preload

<p>ADDRTYPE. Which Address</p> <p>2. RMailAddr</p> <p>TITLE. Title -- e.g. "Mr", "Mrs", "Ms", "Miss", "Dr"</p> <ul style="list-style-type: none"> • If no title, PRESS [Enter] to continue • Ctrl-D and Ctrl-R not allowed; For DK/RF, PRESS [Enter] to continue • VERIFY Title of [Respondent / Reference Person]: [NAME] ([RTH]) <p>String 6</p> <p>NAMF. First Name</p> <ul style="list-style-type: none"> • Ctrl-D and Ctrl-R not allowed; For DK/RF type [DK] or 	<p>INCO. In Care Of</p> <p>[R=RP, SP, OFUM: Now for your complete mailing address, as you would like it to appear on all correspondence from us. First, is there an "in care of" for your address? / R=PROXY: Now for [REFERENCE PERSON]'s complete mailing address. First, is there an "in care of" for the address?]</p> <ul style="list-style-type: none"> • If none, PRESS [Enter] to continue • Ctrl-D and Ctrl-R not allowed; For DK/RF, PRESS [Enter] to continue <p>String 40</p> <p>ADDR1. Address 1</p> <ul style="list-style-type: none"> • IF R says the mailing address contains both a street
---	--

<p>[RF]</p> <ul style="list-style-type: none"> • VERIFY First Name of [Respondent / Reference Person]: [NAME] ([RTH]) <p>String 20</p> <p>NAMM. Middle Name</p> <ul style="list-style-type: none"> • Ask for Middle Name but do not probe DK or RF • If none, PRESS [Enter] to continue • Ctrl-D and Ctrl-R not allowed; For DK/RF, PRESS [Enter] to continue • VERIFY Middle Name of [Respondent / Reference Person]: [NAME] ([RTH]) <p>String 20</p> <p>NAML. Last Name</p> <ul style="list-style-type: none"> • Ctrl-D and Ctrl-R not allowed; For DK/RF type [DK] or [RF] • VERIFY Last Name of [Respondent / Reference Person]: [NAME] ([RTH]) <p>String 20</p> <p>SUFFIX. Suffix -- e.g. "Sr", "Jr"</p> <ul style="list-style-type: none"> • If none, PRESS [Enter] to continue • Ctrl-D and Ctrl-R not allowed; For DK/RF, PRESS [Enter] to continue • VERIFY Suffix of [Respondent / Reference Person]: [NAME] ([RTH]) <p>String 20</p>	<p>address and PO Box: ENTER street address here (Address 1) and ENTER PO Box in Address 2</p> <ul style="list-style-type: none"> • Ctrl-D and Ctrl-R not allowed; For DK/RF type [DK] or [RF] <p>String 40</p> <p>APTSTE. Apt/Suite</p> <ul style="list-style-type: none"> • If none, PRESS [Enter] to continue • Ctrl-D and Ctrl-R not allowed; For DK/RF, PRESS [Enter] to continue <p>String 10</p> <p>ADDR2. Address 2</p> <ul style="list-style-type: none"> • IF R says the mailing address contains both a street address and PO Box: ENTER PO Box here (Address 2) • If none, PRESS [Enter] to continue • Ctrl-D and Ctrl-R not allowed; For DK/RF, PRESS [Enter] to continue <p>String 40</p> <p>CITY. City</p> <ul style="list-style-type: none"> • Ctrl-D and Ctrl-R not allowed; For DK/RF type [DK] or [RF] <p>String 40</p> <p>STATE. State</p> <ul style="list-style-type: none"> • Start typing the name of the State to bring up the look-up list • If foreign country, ENTER [FOR] to select "Foreign Country" <p>String 30; String 4</p> <p>ZIP. Zip Code</p> <ul style="list-style-type: none"> • If foreign country, ENTER all [0]'s • Ctrl-D and Ctrl-R not allowed; For DK/RF ENTER all [0]'s <p>-----</p> <p>COUNTRY. Country if different from USA</p> <ul style="list-style-type: none"> • Start typing the name of the Foreign Country to bring up the look-up list <p>String 30; String 2</p>
---	--

END RMAILADDR

FU Member R Phones (or Reference Person, if R=Proxy)

ADDRPAYMENT.RPHONE Phones prefilled with NewPreload (R=preloaded RP, SP) or RespondentAddr (All other Rs) preload

<p>ADDRTYPE. Which Phone <input type="text" value="2. RMailAddr"/></p> <p>AQSN. AQSN of Respondent (or RP, if R=Proxy)</p> <p>WTRCELL. [Do you / Does [REFERENCE PERSON]] have a <u>cell</u> phone? <ul style="list-style-type: none"> • [R=RP, SP, OFUM: Do NOT ask but ENTER [1] if you know R is using a cell phone] • Ctrl-D and Ctrl-R not allowed; For DK/RF ENTER [5] <input type="text" value="1. Yes"/> <input type="text" value="5. No"/> → GO TO WTRHOME ↓</p> <p>CELLPH. Cell Phone - Area Code and Telephone Number What is the area code and phone number? <ul style="list-style-type: none"> • ASK; or CONFIRM if phone number has been prelisted and this is the same [R=RP, SP, OFUM: Respondent / R=PROXY: Reference Person] as [P2YEAR] • If foreign phone, PRESS [ENTER] to go to foreign phone field • Ctrl-D and Ctrl-R not allowed; For DK/RF, GO BACK and ENTER [5] at WtrCell <input type="text" value="[ENTER]"/> <input type="text" value="()_ _ _ - _ _ _ _"/> → GO TO WTRHOME ↓</p> <p>CELLFOR. Cell Phone - Foreign Number (What is the area code and phone number?) <ul style="list-style-type: none"> • ASK; or CONFIRM if phone number has been prelisted and this is the same [Respondent / Reference Person] as [P2YEAR] • Ctrl-D and Ctrl-R not allowed; For DK/RF, GO BACK and ENTER [5] at WtrCell <input type="text" value="String 20"/></p>	<p>WTRHOME. [Do you / Does [he / she]] have a <u>home</u> phone? <ul style="list-style-type: none"> • Ctrl-D and Ctrl-R not allowed; For DK/RF ENTER [5] <input type="text" value="1. Yes"/> <input type="text" value="5. No"/> → GO TO HSPCKPT ↓</p> <p>HOMEPH. Home Phone - Area Code and Telephone Number What is the area code and phone number? <ul style="list-style-type: none"> • ASK; or CONFIRM if phone number has been prelisted and this is the same [Respondent / Reference Person] as [P2YEAR] • If foreign phone, PRESS [ENTER] to go to foreign phone field • Ctrl-D and Ctrl-R not allowed; For DK/RF, GO BACK and ENTER [5] at WtrHome <input type="text" value="[ENTER]"/> <input type="text" value="()_ _ _ - _ _ _ _"/> → GO TO HSPCKPT ↓</p> <p>HOMEFOR. Home Phone - Foreign Number (What is the area code and phone number?) <ul style="list-style-type: none"> • ASK; or CONFIRM if phone number has been prelisted and this is the same [Respondent / Reference Person] as [P2YEAR] • Ctrl-D and Ctrl-R not allowed; For DK/RF, GO BACK and ENTER [5] at WtrHome <input type="text" value="String 20"/></p>
---	--

END RPHONE

HSPCKPT. CAI Checkpoint: Who is Respondent; Whether Spouse/Partner in FU

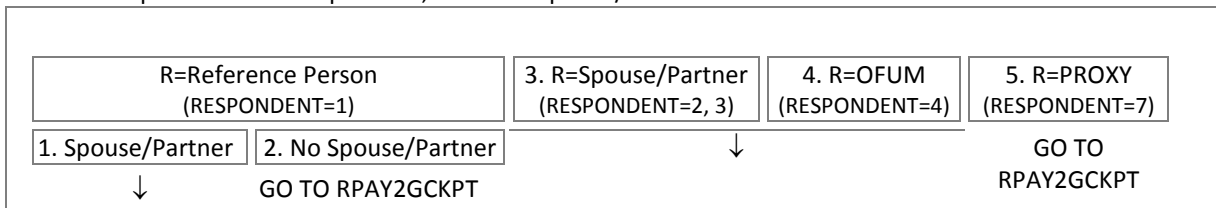

FU Member R's Spouse/Partner Cell Phone (or Reference Person, if R=OFUM)

ADDRPAYMENT.HSPPHONE Phone prefilled with NewPreload (preloaded RP, SP) preload

ADDRTYPE. Which Phone

AQSN. AQSN of Spouse/Partner of Respondent (or Reference Person, if R=OFUM)

WTRCELL. Does [R=SP, OFUM: [REFERENCE PERSON] / R=RP: [SP]] have a cell phone?
 • Ctrl-D and Ctrl-R not allowed; For DK/RF ENTER [5]
 → GO TO RPAY2GCKPT
 ↓

CELLPH. Cell Phone - Area Code and Telephone Number
 What is the area code and phone number?
 • ASK; or CONFIRM if phone number has been prelisted and this is the same [R=SP, OFUM: Reference Person / R=RP: Spouse/Partner] as [P2YEAR]
 • If foreign phone, PRESS [ENTER] to go to foreign phone field
 • Ctrl-D and Ctrl-R not allowed; For DK/RF, GO BACK and ENTER [5] at WtrCell
 → GO TO RPAY2GCKPT
 ↓

CELLFOR. Cell Phone - Foreign Number
 (What is the area code and phone number?)
 • ASK; or CONFIRM if phone number has been prelisted and this is the same [Reference Person / Spouse/Partner] as [P2YEAR]
 • Ctrl-D and Ctrl-R not allowed; For DK/RF, GO BACK and ENTER [5] at WtrCell

END HSPPHONE

RPAY2GCKPT. CAI Checkpoint: Who is Respondent

1. R=Reference Person, Spouse/Partner, OFUM (RESPONDENT=1-4)	2. R=Proxy (RESPONDENT=7)
↓	
GO TO RPAY3A	

FU Member R Email (and R's Spouse/Partner, if R=Reference Person or Spouse/Partner)

ADDRPAYMENT.RPAY2G_H [1-2] [1]=Respondent, [2]=Spouse/Partner of Respondent (R=RP, SP only)

EMAILAQSN. AQSN of Respondent (Spouse/Partner of Respondent)

RPAY2G. [CYNAMF CYNAML]: [CYAQRTH], [CYFUHU], Age [AGEIWDAT]

[LOOP 2: R's 1st Email Address: [[RPAY2H] / No email reported]]

[LOOP 2: R's 2nd Email Address: [[RPAY2J] / No email reported]]

Is there an email address where we can contact [LOOP 1: you / LOOP 2: [RP / SP]]?

1. Yes [LOOP 2: , and is different than R's]	[LOOP 2: 2. Yes, and is same as R's 1 st email]	[LOOP 2: 3. Yes, and is same as R's 2 nd email]	<input type="text" value="5. No"/>
↓		GO TO RPAY2G END RULE	
Assign RPAY2H[2]=RPAY2H[1]		Assign RPAY2H[2]=RPAY2J[1]	
GO TO RPAY2I			

Prefilled with NewPreload (R=preloaded RP, SP) or RespondentAddr (All other Rs) preload

RPAY2H. [CYNAMF CYNAML]: [CYAQRTH], [CYFUHU], Age [AGEIWDATE]

(What is that e-mail address?)

- ASK; or CONFIRM if email address has been prelisted and this is the same [LOOP 1: Respondent / LOOP 2: [Reference Person / Spouse/Partner]] as [P2YEAR]
- ENTER email address, then READ BACK and VERIFY with Respondent
- Ctrl-D and Ctrl-R not allowed; For DK/RF go back and ENTER [Ctrl-D, Ctrl-R] at previous question

String 50

RPAY2I. [CYNAMF CYNAML]: [CYAQRTH], [CYFUHU], Age [AGEIWDATE]

[LOOP 1: R's 1st Email Address: [[RPAY2H] / No email reported]]

[LOOP 2: R's 2nd Email Address: [[RPAY2J] / No email reported]]

[LOOP 2: Spouse/partner's 1st Email Address: [[RPAY2H] / No email reported]]

Is there another email address where we can contact [LOOP 1: you / LOOP 2: [RP / SP]]?

1. Yes [LOOP 2: , and is different than R's]	[LOOP 2 & RPAY2G<>2: 2. Yes, and is same as R's 1 st email]	[LOOP 2 & RPAY2G<>3: 3. Yes, and is same as R's 2 nd email]	5. No
--	--	---	-------

↓

Assign RPAY2J[2]=RPAY2H[1]

Assign RPAY2J[2]=RPAY2J[1]

GO TO RPAY2G END RULE

Prefilled with NewPreload (R=preloaded RP, SP) or RespondentAddr (All other Rs) preload

RPAY2J. [CYNAMF CYNAML]: [CYAQRTH], [CYFUHU], Age [AGEIWDATE]

(What is that e-mail address?)

- ASK; or CONFIRM if email address has been prelisted and this is the same [Respondent / [Reference Person / Spouse/Partner]] as [P2YEAR]
- ENTER email address, then READ BACK and VERIFY with Respondent
- Ctrl-D and Ctrl-R not allowed; For DK/RF go back and ENTER [Ctrl-D, Ctrl-R] at previous question

String 50

RPAY2G END Rule: Who is Respondent; Whether Spouse/Partner in FU

R=Reference Person, Spouse/Partner (RESPONDENT=1-3)	R=OFUM (RESPONDENT=4)
Spouse/Partner (CYFUHU=1, 4 & CYAQRTH=201-222)	No Spouse/Partner
Repeat RPAY2G_H; Then GO TO RPAY3A	↓

END RPAY2G_H

FU Member R Street/Physical Address (or Reference Person, if R=Proxy)

RPAY3A. Is [your / [REFERENCE PERSON]'s] street address where [you / he / she] actually live[s] different from the mailing address? (Can you tell me that address?)

- STREET ADDRESS is the address where R/Reference Person ACTUALLY LIVES, which is sometimes different from R/Reference Person's mailing address
- Ctrl-D and Ctrl-R not allowed; For DK/RF ENTER [5]
- If R cannot report the full street address, ENTER [5]

1. Yes 5. No → GO TO RPAY4PPCKPT

↓

ADDRPAYMENT.RPAY3B

<p>INCO. In Care Of Please tell me that address.</p> <ul style="list-style-type: none"> If none, PRESS [Enter] to continue Ctrl-D and Ctrl-R not allowed; For DK/RF, PRESS [Enter] to continue <p>String 40</p> <p>ADDR1. Address 1</p> <ul style="list-style-type: none"> DO NOT enter PO Box here, since we are asking for a <u>street address</u>. GO BACK to R/Reference Person's mailing address to enter PO Box Ctrl-D and Ctrl-R not allowed; For DK/RF type [DK] or [RF] <p>String 40</p> <p>APTSTE. Apt/Suite</p> <ul style="list-style-type: none"> If none, PRESS [Enter] to continue Ctrl-D and Ctrl-R not allowed; For DK/RF, PRESS [Enter] to continue <p>String 10</p> <p>ADDR2. Address 2</p> <ul style="list-style-type: none"> DO NOT enter PO Box here, since we are asking for a <u>street address</u>. GO BACK to R/Reference Person's mailing address to enter PO Box If none, PRESS [Enter] to continue Ctrl-D and Ctrl-R not allowed; For DK/RF, PRESS [Enter] to continue <p>String 40</p>	<p>CITY. City</p> <ul style="list-style-type: none"> Ctrl-D and Ctrl-R not allowed; For DK/RF type [DK] or [RF] <p>String 40</p> <p>STATE. State</p> <ul style="list-style-type: none"> Start typing the name of the State to bring up the look-up list If foreign country, ENTER [FOR] to select "Foreign Country" <p>String 30; String 4</p> <p>ZIP. Zip Code</p> <ul style="list-style-type: none"> If foreign country, ENTER all [0]'s Ctrl-D and Ctrl-R not allowed; For DK/RF ENTER all [0]'s <p>-----</p> <p>COUNTRY. Country if different from USA</p> <ul style="list-style-type: none"> Start typing the name of the Foreign Country to bring up the look-up list <p>String 30; String 2</p>
--	--

END RPAY3B

RPAY4PPCKPT. CAI Checkpoint: Whether Interview Incentive Was Prepaid

<p>1. Prepaid (WTRPREPAID=1)</p>	<p>5. Not Prepaid (WTRPREPAID=0)</p>	<p>→ GO TO RPAY4A</p>
<p>↓</p>		

Prepayment

RPAY4PP. Interviewer Checkpoint

- This interview was prepaid \${AMTPREPAID} - was the prepayment received? ASK R if needed.
 - The standard payment amount for this interview is \${PAYMENT}
 - Non-standard payment amounts can be \${PAYMENT} to \${PAYMENT*2}
 - Other payment amounts (e.g., in addition to prepaid amount) can be \$1.00 to \${PAYMENT*2}
- Ctrl-D and Ctrl-R not allowed; For DK/RF, ENTER [1]

<p>1. Yes, prepayment received and accepted</p>	<p>→ Assign RPAY4A=1; Then GO TO RPAY5A</p>	<p>2. Yes, prepayment received but a different payment is needed</p>	<p>5. No, prepayment was not received</p>
---	---	--	---

↓

Who Should Receive Payment

RPAY4A. [PREPAID: IWER: This interview was PREPAID \$[AMTPREPAID] but R reported the prepayment was not received or a different/additional payment is needed.]

[R=RP, SP, OFUM: You / R=PROXY: As a proxy respondent, you] may accept the [NOT PREPAID: \$[PAYMENT] / PREPAID: payment] [R=RP, SP, OFUM: or have it sent / R=PROXY: have it sent to [REFERENCE PERSON], or sent] to someone else of your choosing. Which would you prefer?

- Ctrl-D and Ctrl-R not allowed; For DK/RF ENTER [1]

1. Respondent/Proxy accepts payment	[R=PROXY: 2. Proxy wishes that Reference Person receive payment]	3. Other person receives payment	4. Payment declined (If VOL)
GO TO RPAY5A		↓	GO TO RPAY5A

Other Payee Contact Information

ADDRPAYMENT.RPAY4B

<p>ADDRTYPE. Which Address</p> <p><input type="text" value="3. Other Payee"/></p> <p>TITLE. Title -- e.g. "Mr", "Mrs", "Ms", "Miss", "Dr" Who would you like to receive the check? To what address should we send the check?</p> <ul style="list-style-type: none"> • If no title, PRESS [Enter] to continue • Ctrl-D and Ctrl-R not allowed; For DK/RF, PRESS [Enter] to continue <p><input type="text" value="String 6"/></p> <p>NAMF. First Name</p> <ul style="list-style-type: none"> • Ctrl-D and Ctrl-R not allowed; For DK/RF type [DK] or [RF] <p><input type="text" value="String 20"/></p> <p>NAMM. Middle Name</p> <ul style="list-style-type: none"> • Ask for Middle Name but do not probe DK or RF • If none, PRESS [Enter] to continue • Ctrl-D and Ctrl-R not allowed; For DK/RF, PRESS [Enter] to continue <p><input type="text" value="String 20"/></p> <p>NAML. Last Name</p> <ul style="list-style-type: none"> • Ctrl-D and Ctrl-R not allowed; For DK/RF type [DK] or [RF] <p><input type="text" value="String 20"/></p> <p>SUFFIX. Suffix -- e.g. "Sr", "Jr"</p> <ul style="list-style-type: none"> • If none, PRESS [Enter] to continue • Ctrl-D and Ctrl-R not allowed; For DK/RF, PRESS [Enter] to continue <p><input type="text" value="String 20"/></p> <p>INCO. In Care Of</p> <ul style="list-style-type: none"> • If none, PRESS [Enter] to continue 	<p>ADDR1. Address 1</p> <ul style="list-style-type: none"> • IF R says the mailing address contains both a street address and PO Box: ENTER street address here (Address 1) and ENTER PO Box in Address 2 • Ctrl-D and Ctrl-R not allowed; For DK/RF type [DK] or [RF] <p><input type="text" value="String 40"/></p> <p>APTSTE. Apt/Suite</p> <ul style="list-style-type: none"> • If none, PRESS [Enter] to continue • Ctrl-D and Ctrl-R not allowed; For DK/RF, PRESS [Enter] to continue <p><input type="text" value="String 10"/></p> <p>ADDR2. Address 2</p> <ul style="list-style-type: none"> • IF R says the mailing address contains both a street address and PO Box: ENTER PO Box here (Address 2) • If none, PRESS [Enter] to continue • Ctrl-D and Ctrl-R not allowed; For DK/RF, PRESS [Enter] to continue <p><input type="text" value="String 40"/></p> <p>CITY. City</p> <ul style="list-style-type: none"> • Ctrl-D and Ctrl-R not allowed; For DK/RF type [DK] or [RF] <p><input type="text" value="String 40"/></p> <p>STATE. State</p> <ul style="list-style-type: none"> • Start typing the name of the State to bring up the look-up list • If foreign country, ENTER [FOR] to select "Foreign Country" <p><input type="text" value="String 30; String 4"/></p>
---	--

<ul style="list-style-type: none"> Ctrl-D and Ctrl-R not allowed; For DK/RF, PRESS [Enter] to continue <input type="text" value="String 40"/>	<p>ZIP. Zip Code</p> <ul style="list-style-type: none"> If foreign country, ENTER all [0]'s Ctrl-D and Ctrl-R not allowed; For DK/RF ENTER all [0]'s <input type="text" value="-----"/> <p>COUNTRY. Country if different from USA</p> <ul style="list-style-type: none"> Start typing the name of the Foreign Country to bring up the look-up list <input type="text" value="String 30; String 2"/>
--	--

END RPAY4B

ADDRPAYMENT.OPPHONE

<p>ADDRTYPE. Which Phone</p> <input type="text" value="3. Other Payee"/> <p>WTRCELL. Does [OTHER PAYEE] have a <u>cell</u> phone?</p> <ul style="list-style-type: none"> Ctrl-D and Ctrl-R not allowed; For DK/RF ENTER [5] <input type="text" value="1. Yes"/> <input type="text" value="5. No"/> → GO TO WTRHOME ↓ <p>CELLPH. Cell Phone - Area Code and Telephone Number</p> <p>What is the area code and phone number?</p> <ul style="list-style-type: none"> If foreign phone, PRESS [ENTER] to go to foreign phone field Ctrl-D and Ctrl-R not allowed; For DK/RF, GO BACK and ENTER [5] at WtrCell <input type="text" value="[ENTER]"/> <input type="text" value="(____)____-_____"/> → GO TO WTRHOME ↓ <p>CELLFOR. Cell Phone - Foreign Number</p> <p>(What is the area code and phone number?)</p> <ul style="list-style-type: none"> Ctrl-D and Ctrl-R not allowed; For DK/RF, GO BACK and ENTER [5] at WtrCell <input type="text" value="String 20"/>	<p>WTRHOME. [Do you / Does [he / she]] have a <u>home</u> phone?</p> <ul style="list-style-type: none"> Ctrl-D and Ctrl-R not allowed; For DK/RF ENTER [5] <input type="text" value="1. Yes"/> <input type="text" value="5. No"/> → GO TO RPAY5A ↓ <p>HOMEPH. Home Phone - Area Code and Telephone Number</p> <p>What is the area code and phone number?</p> <ul style="list-style-type: none"> If foreign phone, PRESS [ENTER] to go to foreign phone field Ctrl-D and Ctrl-R not allowed; For DK/RF, GO BACK and ENTER [5] at WtrHome <input type="text" value="[ENTER]"/> <input type="text" value="(____)____-_____"/> → GO TO RPAY5A ↓ <p>HOMEFOR. Home Phone - Foreign Number</p> <p>(What is the area code and phone number?)</p> <ul style="list-style-type: none"> Ctrl-D and Ctrl-R not allowed; For DK/RF, GO BACK and ENTER [5] at WtrHome <input type="text" value="String 20"/>
--	---

END OPPHONE

Contact Person 1 Contact Information

RPAY5A. [R=RP, SP, OFUM: Just in case you should move [REINT, RECON, RECLONG: and we don't receive your address update postcard,] we would like the name of someone, such as a close friend or relative not living with you, who will know where we can reach you. / R=PROXY: Just in case [REFERENCE PERSON] should move [REINT, RECON, RECLONG: and we do not receive [his / her] address update postcard,] we would like the name of someone who could help us locate [him / her].]

- ENTER [1] to continue

RPAY5B. Interviewer Checkpoint

- Is there Contact Person 1 information displayed below?

1. Yes, Contact Person is displayed 5. No, no contact person is displayed → GO TO RPAY5D.ADDRTYPE



RPAY5C. Last time, we had [PRELOADED CONTACT PERSON 1] listed as a contact for [you / [REFERENCE PERSON]]. Would you like to continue with this contact?

- ENTER [7] if R refuses Contact Person information

[R=H, SP, OFUM: 1. Yes, continue with this contact] [R=PROXY: 3. Yes, & CP is Proxy] 5. No, change CP info

[R=PROXY: 2. Yes, & CP is not Proxy]

Assign ADDRTYPE=4,
RPAY5D=PROXYADDR,
C1PHONE=PROXYPH, RPAY5JJ=RPAY1FF,
RPAY5K/L= RPAY1G/H; Then GO TO
RPAY6A

GO TO
RPAY5D.ADDRTYPE

7. R refused CP info

GO TO RPAY6A



RPAY5D1. Is the address I have for [PRELOADED CONTACT PERSON 1] correct?

- READ Contact Person 1 address to R

1. Yes, address is correct → Assign ADDRTYPE=4, RPAY5D=PRELOADED CP1; Then GO TO C1PHONE 5. No, address needs updating



ADDRPAYMENT.RPAY5D Name and address prefilled with ContactPerson1 preload

<p>ADDRTYPE. Which Address</p> <p>4. Contact Person 1</p> <p>TITLE. Title -- e.g. "Mr", "Mrs", "Ms", "Miss", "Dr" [RPAY5C=CONTINUE: Does (he/she) still live at this address? / RPAY5C=CHANGE: Who shall I list as a contact person for [you / [REFERENCE PERSON]]? What is (his/her) complete name and mailing address?]</p> <ul style="list-style-type: none"> If needed, REMIND R: This should be someone, such as a close friend or relative <u>not living with [you / [REFERENCE PERSON]]</u>, who will know where we can reach [you / (him / her)] If no title, PRESS [Enter] to continue Ctrl-D and Ctrl-R not allowed; For DK/RF, PRESS [Enter] to continue <p>String 6</p> <p>NAMF. First Name</p> <ul style="list-style-type: none"> Ctrl-D and Ctrl-R not allowed; For DK/RF type [DK] or [RF] <p>String 20</p> <p>NAMM. Middle Name</p> <ul style="list-style-type: none"> Ask for Middle Name but do not probe DK or RF If none, PRESS [Enter] to continue Ctrl-D and Ctrl-R not allowed; For DK/RF, PRESS [Enter] to continue <p>String 20</p> <p>NAML. Last Name</p> <ul style="list-style-type: none"> Ctrl-D and Ctrl-R not allowed; For DK/RF type [DK] or 	<p>ADDR1. Address 1</p> <ul style="list-style-type: none"> If R says the mailing address contains both a street address and PO Box: ENTER street address here (Address 1) and ENTER PO Box in Address 2 Ctrl-D and Ctrl-R not allowed; For DK/RF type [DK] or [RF] <p>String 40</p> <p>APTSTE. Apt/Suite</p> <ul style="list-style-type: none"> If none, PRESS [Enter] to continue Ctrl-D and Ctrl-R not allowed; For DK/RF, PRESS [Enter] to continue <p>String 10</p> <p>ADDR2. Address 2</p> <ul style="list-style-type: none"> If R says the mailing address contains both a street address and PO Box: ENTER PO Box here (Address 2) If none, PRESS [Enter] to continue Ctrl-D and Ctrl-R not allowed; For DK/RF, PRESS [Enter] to continue <p>String 40</p> <p>CITY. City</p> <ul style="list-style-type: none"> Ctrl-D and Ctrl-R not allowed; For DK/RF type [DK] or [RF] <p>String 40</p> <p>STATE. State</p> <ul style="list-style-type: none"> Start typing the name of the State to bring up the look-up list If foreign country, ENTER [FOR] to select "Foreign
--	--

<p>[RF]</p> <p>String 20</p> <p>SUFFIX. Suffix -- e.g. "Sr", "Jr"</p> <ul style="list-style-type: none"> • If none, PRESS [Enter] to continue • Ctrl-D and Ctrl-R not allowed; For DK/RF, PRESS [Enter] to continue <p>String 20</p> <p>INCO. In Care Of</p> <p>Is there an "in care of" for this address?</p> <ul style="list-style-type: none"> • If none, PRESS [Enter] to continue • Ctrl-D and Ctrl-R not allowed; For DK/RF, PRESS [Enter] to continue <p>String 40</p>	<p>Country"</p> <p>String 30; String 4</p> <p>ZIP. Zip Code</p> <ul style="list-style-type: none"> • If foreign country, ENTER all [0]'s • Ctrl-D and Ctrl-R not allowed; For DK/RF ENTER all [0]'s <p>-----</p> <p>COUNTRY. Country if different from USA</p> <ul style="list-style-type: none"> • Start typing the name of the Foreign Country to bring up the look-up list <p>String 30; String 2</p>
---	---

END RPAY5D

ADDRPAYMENT.C1PHONE *Phones prefilled with ContactPerson1 preload*

<p>ADDRTYPE. Which Phone</p> <p>4. Contact Person 1</p> <p>WTRCELL. Does [RPAY5D.NAMF RPAY5D.NAML] have a <u>cell</u> phone?</p> <ul style="list-style-type: none"> • Ctrl-D and Ctrl-R not allowed; For DK/RF ENTER [5] <p>1. Yes 5. No → GO TO WTRHOME</p> <p>↓</p> <p>CELLPH. Cell Phone - Area Code and Telephone Number</p> <p>What is the area code and phone number?</p> <ul style="list-style-type: none"> • ASK; or CONFIRM if phone number has been prelisted and this is the same Contact Person as [P2YEAR] • If foreign phone, PRESS [ENTER] to go to foreign phone field • Ctrl-D and Ctrl-R not allowed; For DK/RF, GO BACK and ENTER [5] at WtrCell <p>[ENTER] (____)____-_____ → GO TO WTRHOME</p> <p>↓</p> <p>CELLFOR. Cell Phone - Foreign Number</p> <p>(What is the area code and phone number?)</p> <ul style="list-style-type: none"> • ASK; or CONFIRM if phone number has been prelisted and this is the same Contact Person as [P2YEAR] • Ctrl-D and Ctrl-R not allowed; For DK/RF, GO BACK and ENTER [5] at WtrCell <p>String 20</p>	<p>WTRHOME. Does [RPAY5D.NAMF RPAY5D.NAML] have a home phone?</p> <ul style="list-style-type: none"> • Ctrl-D and Ctrl-R not allowed; For DK/RF ENTER [5] <p>1. Yes 5. No → GO TO RPAY5JJ</p> <p>↓</p> <p>HOMEPH. Home Phone - Area Code and Telephone Number</p> <p>What is the area code and phone number?</p> <ul style="list-style-type: none"> • ASK; or CONFIRM if phone number has been prelisted and this is the same Contact Person as [P2YEAR] • If foreign phone, PRESS [ENTER] to go to foreign phone field • Ctrl-D and Ctrl-R not allowed; For DK/RF, GO BACK and ENTER [5] at WtrHome <p>[ENTER] (____)____-_____ → GO TO RPAY5JJ</p> <p>↓</p> <p>HOMEFOR. Home Phone - Foreign Number</p> <p>(What is the area code and phone number?)</p> <ul style="list-style-type: none"> • ASK; or CONFIRM if phone number has been prelisted and this is the same Contact Person as [P2YEAR] • Ctrl-D and Ctrl-R not allowed; For DK/RF, GO BACK and ENTER [5] at WtrHome <p>String 20</p>
---	--

END C1PHONE

RPAY5JJ. What is (his / her) relationship to [you / [REFERENCE PERSON]]?

1. Mother	2. Father	3. Son	4. Daughter	5. Sister	6. Brother
7. Aunt	8. Uncle	9. Grandmother	10. Grandfather	11. Friend	12. Father-in-law
13. Mother-in-law	14. Cousin	97. Other-Specify (RPAY5JJSPEC. Specify. (String 50))			

Emails prefilled with ContactPerson1 preload

RPAY5K. Is there an email address where we can contact [RPAY5D.NAMF RPAY5D.NAML]?

1. Yes 5. No → GO TO RPAY6A



RPAY5L. (What is that e-mail address?)

- ASK; or CONFIRM if email address has been prelisted and this is the same Contact Person as [P2YEAR]
- ENTER email address, then READ BACK and VERIFY with Respondent
- Ctrl-D and Ctrl-R not allowed; For DK/RF go back and ENTER [Ctrl-D, Ctrl-R] at previous question

RPAY5M. Is there another email address where we can contact [RPAY5D.NAMF RPAY5D.NAML]?

1. Yes 5. No → GO TO RPAY6A



RPAY5N. (What is that e-mail address?)

- ASK; or CONFIRM if email address has been prelisted and this is the same Contact Person as [P2YEAR]
- ENTER email address, then READ BACK and VERIFY with Respondent
- Ctrl-D and Ctrl-R not allowed; For DK/RF go back and ENTER [Ctrl-D, Ctrl-R] at previous question

Contact Person 2 Contact Information

RPAY6A. Interviewer Checkpoint

- Is there Contact Person 2 information displayed below?

1. Yes, Contact Person is displayed 5. No, no contact person is displayed → GO TO RPAY6C



RPAY6B. Last time, we had [PRELOADED CONTACT PERSON 2] listed as a contact for [you / [REFERENCE PERSON]]. Would you like to continue with this contact?

- ENTER [7] if R refuses Contact Person information

<input type="text" value="[R=H, SP, OFUM: 1. Yes, continue with this contact]"/>	<input type="text" value="[R=PROXY: 3. Yes, & CP is Proxy]"/>	<input type="text" value="5. No, change CP info"/>
<input type="text" value="[R=PROXY: 2. Yes, & CP is not Proxy]"/>	Assign ADDRTYPE=5, RPAY6D=PROXYADDR, C2PHONE=PROXYPH, RPAY6JJ=RPAY1FF, RPAY6K/L= RPAY1G/H; Then GO TO TY1 RULE	GO TO RPAY6D.ADDRTYPE
GO TO RPAY6D1		<input type="text" value="7. R refused CP info"/> GO TO TY1 RULE

RPAY6C. We would like to have the name of a second contact person, someone who will know where we can reach [you / [RP]] if the first contact is not able to help us. Is there a second contact person who can help us reach [you / [RP]]?

- If needed, REMIND R: This should be someone, such as a close friend or relative not living with [you / [RP]], who will know where we can reach [you / (him / her)]

1. Yes → GO TO RPAY6D 5. No → GO TO TY1 RULE

RPAY6D1. Is the address I have for [PRELOADED CONTACT PERSON 2] correct?

- READ Contact Person 2 address to R

1. Yes, address is correct → Assign ADDRTYPE=5, RPAY6D=PRELOADED CP2; 5. No, address needs updating
Then GO TO C2PHONE



ADDRPAYMENT.RPAY6D Name and address prefilled with ContactPerson2 preload

<p>ADDRTYPE. Which Address <input type="text" value="5. Contact Person 2"/></p> <p>TITLE. Title -- e.g. "Mr", "Mrs", "Ms", "Miss", "Dr" <small>[RPAY6B=CONTINUE: Does (he/she) still live at this address? / RPAY6B=CHANGE: Who shall I list as a contact person for [you / [REFERENCE PERSON]]? What is (his/her) complete name and mailing address?]</small></p> <ul style="list-style-type: none"> • If needed, REMIND R: This should be someone, such as a close friend or relative <u>not living with [you / [REFERENCE PERSON]]</u>, who will know where we can reach [you / (him / her)] • If no title, PRESS [Enter] to continue • Ctrl-D and Ctrl-R not allowed; For DK/RF, PRESS [Enter] to continue <input type="text" value="String 6"/> <p>NAMF. First Name</p> <ul style="list-style-type: none"> • Ctrl-D and Ctrl-R not allowed; For DK/RF type [DK] or [RF] <input type="text" value="String 20"/> <p>NAMM. Middle Name</p> <ul style="list-style-type: none"> • Ask for Middle Name but do not probe DK or RF • If none, PRESS [Enter] to continue • Ctrl-D and Ctrl-R not allowed; For DK/RF, PRESS [Enter] to continue <input type="text" value="String 20"/> <p>NAML. Last Name</p> <ul style="list-style-type: none"> • Ctrl-D and Ctrl-R not allowed; For DK/RF type [DK] or [RF] <input type="text" value="String 20"/> <p>SUFFIX. Suffix -- e.g. "Sr", "Jr"</p> <ul style="list-style-type: none"> • If none, PRESS [Enter] to continue • Ctrl-D and Ctrl-R not allowed; For DK/RF, PRESS [Enter] to continue 	<p>ADDR1. Address 1</p> <ul style="list-style-type: none"> • If R says the mailing address contains both a street address and PO Box: ENTER street address here (Address 1) and ENTER PO Box in Address 2 • Ctrl-D and Ctrl-R not allowed; For DK/RF type [DK] or [RF] <input type="text" value="String 40"/> <p>APTSTE. Apt/Suite</p> <ul style="list-style-type: none"> • If none, PRESS [Enter] to continue • Ctrl-D and Ctrl-R not allowed; For DK/RF, PRESS [Enter] to continue <input type="text" value="String 10"/> <p>ADDR2. Address 2</p> <ul style="list-style-type: none"> • If R says the mailing address contains both a street address and PO Box: ENTER PO Box here (Address 2) • If none, PRESS [Enter] to continue • Ctrl-D and Ctrl-R not allowed; For DK/RF, PRESS [Enter] to continue <input type="text" value="String 40"/> <p>CITY. City</p> <ul style="list-style-type: none"> • Ctrl-D and Ctrl-R not allowed; For DK/RF type [DK] or [RF] <input type="text" value="String 40"/> <p>STATE. State</p> <ul style="list-style-type: none"> • Start typing the name of the State to bring up the look-up list • If foreign country, ENTER [FOR] to select "Foreign Country" <input type="text" value="String 30; String 4"/> <p>ZIP. Zip Code</p> <ul style="list-style-type: none"> • If foreign country, ENTER all [0]'s • Ctrl-D and Ctrl-R not allowed; For DK/RF ENTER all [0]'s <input type="text" value="-----"/>
--	--

<p>String 20</p> <p>INCO. In Care Of Is there an "in care of" for this address?</p> <ul style="list-style-type: none"> • If none, PRESS [Enter] to continue • Ctrl-D and Ctrl-R not allowed; For DK/RF, PRESS [Enter] to continue <p>String 40</p>	<p>COUNTRY.Country if different from USA</p> <ul style="list-style-type: none"> • Start typing the name of the Foreign Country to bring up the look-up list <p>String 30; String 2</p>
---	--

END RPAY6D

ADDRPAYMENT.C2PHONE *Phones prefilled with ContactPerson2 preload*

<p>ADDRTYPE. Which Phone</p> <p>5. Contact Person 2</p> <p>WTRCELL. [Do you / Does [REFERENCE PERSON]] have a <u>cell</u> phone?</p> <ul style="list-style-type: none"> • Ctrl-D and Ctrl-R not allowed; For DK/RF ENTER [5] <p>1. Yes 5. No → GO TO WTRHOME</p> <p>↓</p> <p>CELLPH. Cell Phone - Area Code and Telephone Number What is the area code and phone number?</p> <ul style="list-style-type: none"> • ASK; or CONFIRM if phone number has been prelisted and this is the same Contact Person as [P2YEAR] • If foreign phone, PRESS [ENTER] to go to foreign phone field • Ctrl-D and Ctrl-R not allowed; For DK/RF, GO BACK and ENTER [5] at WtrCell <p>[ENTER] (____)____-____ → GO TO WTRHOME</p> <p>↓</p> <p>CELLFOR. Cell Phone - Foreign Number (What is the area code and phone number?)</p> <ul style="list-style-type: none"> • ASK; or CONFIRM if phone number has been prelisted and this is the same Contact Person as [P2YEAR] • Ctrl-D and Ctrl-R not allowed; For DK/RF, GO BACK and ENTER [5] at WtrCell <p>String 20</p>	<p>WTRHOME. [Do you / Does [he / she]] have a <u>home</u> phone?</p> <ul style="list-style-type: none"> • Ctrl-D and Ctrl-R not allowed; For DK/RF ENTER [5] <p>1. Yes 5. No → GO TO RPAY6JJ</p> <p>↓</p> <p>HOMEPH. Home Phone - Area Code and Telephone Number What is the area code and phone number?</p> <ul style="list-style-type: none"> • ASK; or CONFIRM if phone number has been prelisted and this is the same Contact Person as [P2YEAR] • If foreign phone, PRESS [ENTER] to go to foreign phone field • Ctrl-D and Ctrl-R not allowed; For DK/RF, GO BACK and ENTER [5] at WtrHome <p>[ENTER] (____)____-____ → GO TO RPAY6JJ</p> <p>↓</p> <p>HOMEFOR. Home Phone - Foreign Number (What is the area code and phone number?)</p> <ul style="list-style-type: none"> • ASK; or CONFIRM if phone number has been prelisted and this is the same Contact Person as [P2YEAR] • Ctrl-D and Ctrl-R not allowed; For DK/RF, GO BACK and ENTER [5] at WtrHome <p>String 20</p>
--	---

END C2PHONE

RPAY6JJ. What is (his / her) relationship to [you / [RP]]?

1. Mother	2. Father	3. Son	4. Daughter	5. Sister	6. Brother
7. Aunt	8. Uncle	9. Grandmother	10. Grandfather	11. Friend	12. Father-in-law
13. Mother-in-law	14. Cousin	97. Other-Specify (RPAY6JJSPEC. Specify. (String 50))			

Emails prefilled with ContactPerson2 preload

RPAY6K. Is there an email address where we can contact [RPAY6D.NAMF RPAY6D.NAML]?

1. Yes 5. No → GO TO TY1 RULE



RPAY6L. (What is that e-mail address?)

- ASK; or CONFIRM if email address has been prelisted and this is the same Contact Person as [P2YEAR]
- ENTER email address, then READ BACK and VERIFY with Respondent
- Ctrl-D and Ctrl-R not allowed; For DK/RF go back and ENTER [Ctrl-D, Ctrl-R] at previous question

RPAY6M. Is there another email address where we can contact [RPAY6D.NAMF RPAY6D.NAML]?

1. Yes 5. No → GO TO TY1 RULE



RPAY6N. (What is that e-mail address?)

- ASK; or CONFIRM if email address has been prelisted and this is the same Contact Person as [P2YEAR]
- ENTER email address, then READ BACK and VERIFY with Respondent
- Ctrl-D and Ctrl-R not allowed; For DK/RF go back and ENTER [Ctrl-D, Ctrl-R] at previous question

TY1 Rule: Whether TAS Eligible Individuals Age 17 or Older in FU

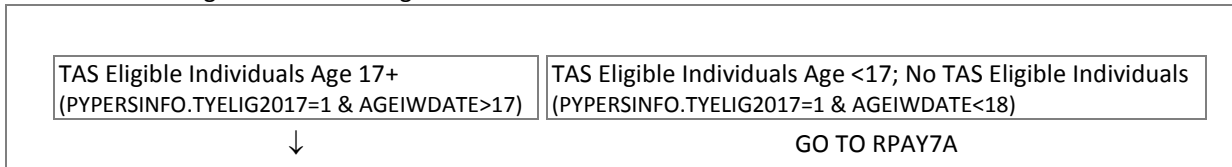

TAS Contact Information

ADDRPAYMENT.TY [1-24] [1-24]=AQSN of FU Member

TYAQSN. AQSN of TAS FU Member

TY1. **TAS Eligible Person:** [CYNAMF CYNAML] [CYAQRTH]

[R=TAS FU MEMBER: You / ALL OTHERS: [CYNAMF CYNAML]] [AGE=17: may [LOOP 2+: also] be / AGE>17: [are / is] [LOOP 2+: also]] eligible to participate in the F.E.S. (Family Economics Study) Transition into Adulthood Study (TAS) we will be doing in the near future. Will we be able to reach [you / [him / her]] at [CYFUHU=FU, FUMI: your current address / CYFUHU=MO, MIL, EDUC: the address that you gave me earlier]?

1. Yes → GO TO PHONECKPT 5. No DK/RF



TY2. **TAS Eligible Person:** [CYNAMF CYNAML] [CYAQRTH]

Do you know what [your / his / her] new address will be?

1. Yes 5. No → GO TO PHONECKPT



<p>ADDR1. TAS Eligible Person: [CYNAMF CYNAML] [CYAQRTH] Address 1</p> <ul style="list-style-type: none"> • Enter P.O. Box in Addr2 • Record complete street address including apartment/suite number here • Record any college or university or military base name here • Ctrl-D and Ctrl-R not allowed; For DK/RF type [DK] or [RF] <p>String 40</p> <p>ADDR2. TAS Eligible Person: [CYNAMF] [CYNAML] [CYAQRTH] Address 2</p> <ul style="list-style-type: none"> • Enter P.O. Box here • If none, PRESS [Enter] to continue • Ctrl-D and Ctrl-R not allowed; For DK/RF, PRESS [Enter] to continue <p>String 40</p> <p>CITY. TAS Eligible Person: [CYNAMF CYNAML] [CYAQRTH] City</p> <ul style="list-style-type: none"> • Ctrl-D and Ctrl-R not allowed; For DK/RF type [DK] or [RF] <p>String 40</p>	<p>STATE. TAS Eligible Person: [CYNAMF CYNAML] [CYAQRTH] State</p> <ul style="list-style-type: none"> • Start typing the name of the State to bring up the look-up list • If foreign country, ENTER [FOR] to select "Foreign Country" <p>String 30; String 4</p> <p>ZIP. TAS Eligible Person: [CYNAMF CYNAML] [CYAQRTH] Zip Code</p> <ul style="list-style-type: none"> • If foreign country, ENTER all [0]'s • Ctrl-D and Ctrl-R not allowed; For DK/RF ENTER all [0]'s <p>-----</p> <p>COUNTRY. TAS Eligible Person: [CYNAMF CYNAML] [CYAQRTH] Country if different from USA</p> <ul style="list-style-type: none"> • Start typing the name of the Foreign Country to bring up the look-up list <p>String 30; String 2</p>
--	---

PHONECKPT. CAI Checkpoint: Whether Cell Phone Already Collected for This TAS FU Member

1. TAS FU Member is R	2. TAS FU Member is RP or SP (TAS is SP & R=RP; TAS is RP & R=SP, OFUM, Proxy)	5. All Others
GO TO EMAILCKPT		↓

WTRCELL. TAS Eligible Person: [CYNAMF CYNAML] [CYAQRTH]
[Do you / Does [CYNAMF CYNAML]] have a cell phone?

- Ctrl-D and Ctrl-R not allowed; For DK/RF ENTER [5]

1. Yes 5. No → GO TO WTRHOME



CELLPH. Cell Phone for TAS Eligible Person: [CYNAMF CYNAML] [CYAQRTH]
What is the area code and phone number?

- If foreign phone, PRESS [ENTER] to go to foreign phone field
- Ctrl-D and Ctrl-R not allowed; For DK/RF, GO BACK and ENTER [5] at WtrCell

[ENTER] (____)____-____ → GO TO WTRHOME



CELLFOR. Cell Phone for TAS Eligible Person: [CYNAMF CYNAML] [CYAQRTH]

(What is the area code and phone number?)

- Ctrl-D and Ctrl-R not allowed; For DK/RF, GO BACK and ENTER [5] at WtrCell

String 20

EMAILCKPT. CAI Checkpoint: Whether Cell Phone Already Collected for TAS FU Member

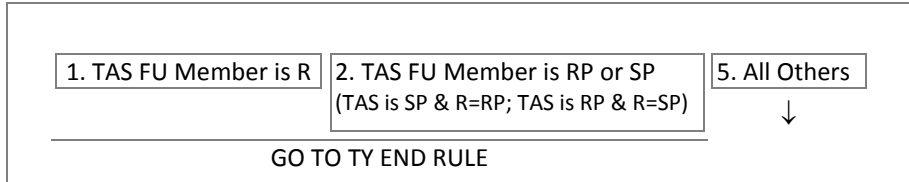

TYEMAIL. TAS Eligible Person: [CYNAMF CYNAML] [CYAQRTH]

Is there an email address where we will be able to contact [CYNAMF CYNAML]?

1. Yes 5. No → GO TO TY END RULE



TYEMAILADDR. TAS Eligible Person: [CYNAMF CYNAML] [CYAQRTH]

(What is that email address?)

- ENTER email address, then READ BACK and VERIFY with Respondent
- Ctrl-D and Ctrl-R not allowed; For DK/RF go back and ENTER [Ctrl-D, Ctrl-R] at previous question

String 50

TYEMAIL2. TAS Eligible Person: [CYNAMF CYNAML] [CYAQRTH]

Is there another email address where we will be able to contact [CYNAMF CYNAML]?

1. Yes 5. No → GO TO TY END RULE



TYEMAIL2ADDR. TAS Eligible Person: [CYNAMF CYNAML] [CYAQRTH]

(What is that email address?)

- ENTER email address, then READ BACK and VERIFY with Respondent
- Ctrl-D and Ctrl-R not allowed; For DK/RF go back and ENTER [Ctrl-D, Ctrl-R] at previous question

String 50

TY END Rule: Whether More Eligible TAS FU Members in FU

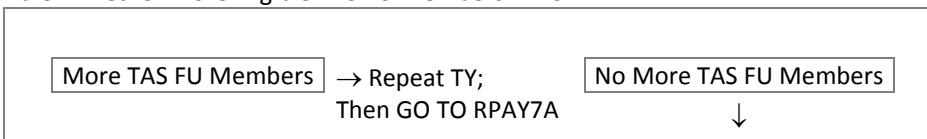

END TY

RPAY7A. Interviewer Checkpoint

- Are there others in this family folder whose address and phone number need updating?

1. Yes 5. No → GO TO RPAY7C



RPAY7B. We would like to update our address and phone number information for other members of [your / RP]'s family who are also participants in our study. Could you help me with that?

- If Yes, make paper notes to update address information - enter in SurveyTrak later

1. Yes 5. No

NOTE: If SurveyTrak *tsample_line.vext_059* (Was cell phone payment offered?) =Yes/No, then value "1" is pushed into RPAY7C.

RPAY7C. Interviewer Checkpoint

- Did Respondent use a cell phone to complete this interview?

1. Yes

5. No → GO TO RPAY9ACKPT

SIGNAL for RPAY7C=YES: IWER: You entered that R completed this interview using a cell phone. If this is true, click Suppress to confirm. If R did not use a cell phone to complete this interview, click Close and change your response to No.



RPAY7D. Interviewer Checkpoint

- Was a cell phone payment offered by you or anyone else?

1. Yes 5. No

RPAY9ACKPT. CAI Checkpoint: Whether Payment Accepted or Declined

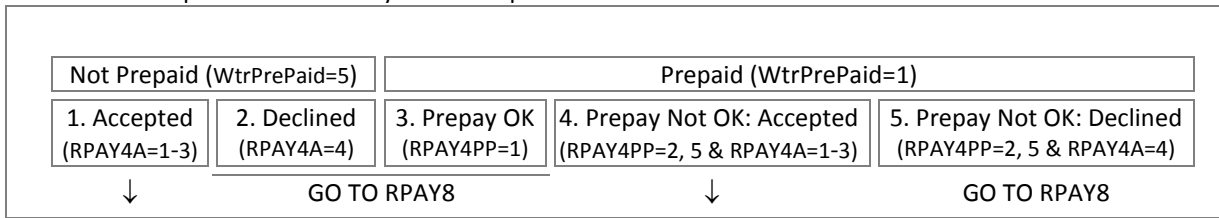

Payment

(AddrPayment.xEPDisplay=0; Electronic payment instructions and response option 6 not included)

RPAY9A. Interviewer Checkpoint

NOT PREPAID: Tell us the type of Respondent payment to make

- The standard payment amount for this interview is \$[PAYMENT]
- Non-standard payment amounts can be \$[PAYMENT] to \$[PAYMENT*2]
- ENTER [1, 7] or [2, 7] to record a cell phone payment and/or temporary mailing address **in addition to** a standard check/money order
- Ctrl-D and Ctrl-R not allowed

PREPAID: IWER: This interview was PREPAID \$[AMTPREPAID] but R reported the prepayment was not received or a different/additional payment is needed

- The standard payment amount for this interview is \$[PAYMENT]
- Non-standard payment amounts can be \$[PAYMENT] to \$[PAYMENT*2]
- Other payment amounts (e.g., in addition to prepaid amount) can be \$1.00 to \$[PAYMENT*2]
- ENTER [5] if a cash payment was made or ENTER [7] to request a check payment or special handling
- Ctrl-D and Ctrl-R not allowed

NOT PREPAID: 1. Pay by check in standard amount of \$[PAYMENT]	Exclusive of 2, 5
NOT PREPAID: 2. Pay by money order in standard amount of \$[PAYMENT]	Exclusive of 1, 5
5. Cash payment made	Exclusive of 1, 2, 7
7. Special handling: [NOT PREPAID: Non-standard payment / PREPAID: Payment] amount, cell phone payment, temporary address	

SIGNAL for RPAY9A=MO: You have selected money order as method of payment. READ TO R: A money order would delay payment by 1-2 weeks, and if it is lost cannot be replaced for 6-8 weeks. Is that okay or should we issue a check instead? Change your selection to [1. Check] if necessary.

SIGNAL for RPAY7D=YES & RPAY9A=CHECK, MO & RPAY9A<>SPECIAL HANDLING: INTERVIEW WAS COMPLETED USING CELL PHONE and CELL PHONE PAYMENT HAS BEEN OFFERED. Standard payments by check or money order: ENTER [7] in addition to [1] or [2]. Non-standard payment amounts: ENTER [7]. Cash payments: a separate screen will automatically ask for cell phone payment amount.

(AddrPayment.xEPDisplay=0; Electronic payment not included)

RPAY9B RULE. Type of Payment Selected

Standard Check or Money Order Only (RPAY9A=1, 2)	Cash (RPAY9A=5)	Special Handling (RPAY9A=(1, 2) & 7)
GO TO RPAY8	↓	GO TO RPAY9D

Cash Payment

RPAY9B. *[PREPAID: IWER: This interview was PREPAID \${AMTPREPAID} but R reported the prepayment was not received or a different/additional payment is needed]*

When did you make the [PREPAID: different /additional] cash payment?

- ENTER MM/DD/[CYEAR], with or without slashes
- Ctrl-D and Ctrl-R not allowed

RPAY9C. *[PREPAID: IWER: This interview was PREPAID \${AMTPREPAID} but R reported the prepayment was not received or a different/additional payment is needed]*

How much was the cash Respondent payment for this interview?

- The standard payment amount for this interview is \${PAYMENT}
- Non-standard payment amounts can be \${PAYMENT} to \${PAYMENT*2}
- *[PREPAID: Other payment amounts (e.g., in addition to prepaid amount) can be \$1.00 to \${PAYMENT*2}]*
- DO NOT INCLUDE amount for cell phone payment here - record this separately at the next screen
- Ctrl-D and Ctrl-R not allowed

NOT PREPAID

PREPAID

RPAY9C2. *How much, if any, was the cash Respondent payment for cell phone use?*

- ENTER either \$0.00 or \$10.00
- Standard payment for cell phone use is \$10.00
- Ctrl-D and Ctrl-R not allowed

SIGNAL FOR RPAY9C=0 & RPAY7D=YES: INTERVIEW WAS COMPLETED USING CELL PHONE and CELL PHONE PAYMENT HAS BEEN OFFERED. Cash payments: RECORD amount paid for cell phone use.

GO TO RPAY8

Special Handling

(AddrPayment.xEPDisplay=0; Electronic response options 5 & 6 not included)

RPAY9D. [PREPAID: IWER: This interview was PREPAID \$[AMTPREPAID] but R reported the prepayment was not received or a different/additional payment is needed]

Please indicate the type(s) of [PREPAID: payment/] special handling needed.

- ENTER all that apply
- Ctrl-D and Ctrl-R not allowed

NOT PREPAID & RPAY9A<>CHECK, MO: 1. Non-standard IW payment-check

2. Temporary mailing address

3. Cell phone use payment, \$10

PREPAID: 4. Additional or new payment-check

7. Other-specify (RPAY9DSPEC. Please specify other special handling needed. But, go back to temporary address to record address where payment should be sent. (String 500))

SIGNAL FOR RPAY7D=YES & RPAY9D<>CELL PAYMENT: INTERVIEW WAS COMPLETED USING CELL PHONE and CELL PHONE PAYMENT HAS BEEN OFFERED. Standard and non-standard payments: ENTER [3] to select cell phone payment.

(AddrPayment.xEPDisplay=0; Electronic payment not included)

RPAY9DAMT RULE. Type of Special Handling

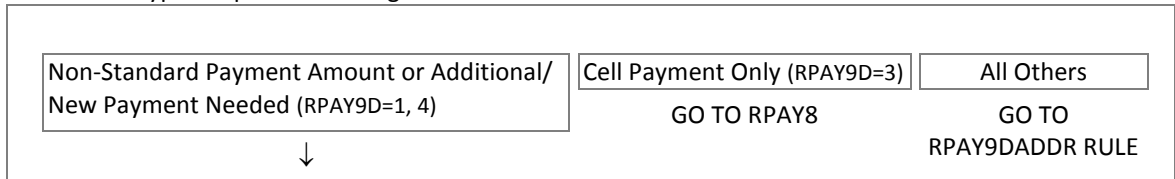

Special Handling - Non-Standard Amount or Additional/New Payment

RPAY9DAMT. [PREPAID: IWER: This interview was PREPAID \$[AMTPREPAID] but R reported the prepayment was not received or a different/additional payment is needed]

How much is the Respondent payment for this interview?

- The standard payment amount for this interview is \$[PAYMENT]
- Non-standard payment amounts can be \$[PAYMENT] to \$[PAYMENT*2]
- [PREPAID: Other payment amounts (e.g., in addition to prepaid amount) can be \$1.00 to \$[PAYMENT*2]]
- DO NOT INCLUDE amount for cell phone payment here - a separate check must be issued for cell phone payment. Go back to RPay9d and select "3 - Cell phone payment"
- Ctrl-D and Ctrl-R not allowed

NOT PREPAID \$[PAYMENT] – [PAYMENT*2]

PREPAID \$1.00 – [PAYMENT*2]

(AddrPayment.xEPDisplay=0; GO TO RPAY9EP1 RULE not included)

RPAY9DADDR RULE. Whether Temporary Mailing Address Selected

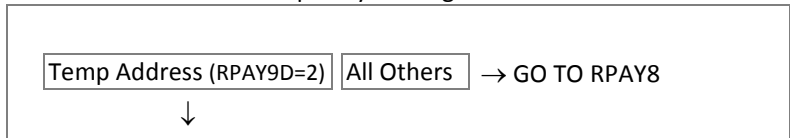

Special Handling - Temporary Mailing Address

ADDRPAYMENT.RPAY9DADDR

<p>ADDRTYPE. Which Address</p> <p><input type="text" value="8. Temporary Mailing"/></p> <p>TITLE. Title -- e.g. "Mr", "Mrs", "Ms", "Miss", "Dr" What is that name and address?</p> <ul style="list-style-type: none"> If no title, PRESS [Enter] to continue Ctrl-D and Ctrl-R not allowed; For DK/RF, PRESS [Enter] to continue <p><input type="text" value="String 6"/></p> <p>NAMF. First Name</p> <ul style="list-style-type: none"> Ctrl-D and Ctrl-R not allowed; For DK/RF type [DK] or [RF] <p><input type="text" value="String 20"/></p> <p>NAMM. Middle Name</p> <ul style="list-style-type: none"> Ask for Middle Name but do not probe DK or RF If none, PRESS [Enter] to continue Ctrl-D and Ctrl-R not allowed; For DK/RF, PRESS [Enter] to continue <p><input type="text" value="String 20"/></p> <p>NAML. Last Name</p> <ul style="list-style-type: none"> Ctrl-D and Ctrl-R not allowed; For DK/RF type [DK] or [RF] <p><input type="text" value="String 20"/></p> <p>SUFFIX. Suffix -- e.g. "Sr", "Jr"</p> <ul style="list-style-type: none"> If none, PRESS [Enter] to continue Ctrl-D and Ctrl-R not allowed; For DK/RF, PRESS [Enter] to continue <p><input type="text" value="String 20"/></p> <p>INCO. In Care Of</p> <p>Is there an "in care of" for this address?</p> <ul style="list-style-type: none"> If none, PRESS [Enter] to continue Ctrl-D and Ctrl-R not allowed; For DK/RF, PRESS [Enter] to continue <p><input type="text" value="String 40"/></p>	<p>ADDR1. Address 1</p> <ul style="list-style-type: none"> If R says the mailing address contains both a street address and PO Box: ENTER street address here (Address 1) and ENTER PO Box in Address 2 Ctrl-D and Ctrl-R not allowed; For DK/RF type [DK] or [RF] <p><input type="text" value="String 40"/></p> <p>APTSTE. Apt/Suite</p> <ul style="list-style-type: none"> If none, PRESS [Enter] to continue Ctrl-D and Ctrl-R not allowed; For DK/RF, PRESS [Enter] to continue <p><input type="text" value="String 10"/></p> <p>ADDR2. Address 2</p> <ul style="list-style-type: none"> If R says the mailing address contains both a street address and PO Box: ENTER PO Box here (Address 2) If none, PRESS [Enter] to continue Ctrl-D and Ctrl-R not allowed; For DK/RF, PRESS [Enter] to continue <p><input type="text" value="String 40"/></p> <p>CITY. City</p> <ul style="list-style-type: none"> Ctrl-D and Ctrl-R not allowed; For DK/RF type [DK] or [RF] <p><input type="text" value="String 40"/></p> <p>STATE. State</p> <ul style="list-style-type: none"> Start typing the name of the State to bring up the look-up list If foreign country, ENTER [FOR] to select "Foreign Country" <p><input type="text" value="String 30; String 4"/></p> <p>ZIP. Zip Code</p> <ul style="list-style-type: none"> If foreign country, ENTER all [0]'s Ctrl-D and Ctrl-R not allowed; For DK/RF ENTER all [0]'s <p><input type="text" value="-----"/></p> <p>COUNTRY. Country if different from USA</p> <ul style="list-style-type: none"> Start typing the name of the Foreign Country to bring up the look-up list <p><input type="text" value="String 30; String 2"/></p>
---	--

END RPAY9DADDR

(AddrPayment.xEPDisplay=0; RPay9EP1 Rule, RPay9EP1, RPay9EPCkpt, RPay9EP2, RPay9EP3 not included)
 CHECK for no payment selected (RPAY4A<>Declined & RPAY9A<>Check, Money Order, Cash & RPAY9D<>Non-standard, Additional/New):
 You must select an interview payment type at RPAY9A or RPAY9D.

Thank You

RPAY8. Thank you, these are all the questions I have for you. As part of our quality control procedures, another interviewer from The University of Michigan may call you back to ask a few questions about this interview and to answer any questions you may have about the interview process.

- ENTER [1] to continue

IWPAYWHO. Who Receives Interview Payment

<input type="text" value="1. Reference Person"/>	<input type="text" value="2. Spouse"/>	<input type="text" value="3. Partner"/>	<input type="text" value="4. OFUM"/>
<input type="text" value="5. Declined"/>	<input type="text" value="6. Other payee"/>	<input type="text" value="7. Proxy"/>	<input type="text" value="8. None; Prepay okay"/>

(AddrPayment.xEPDisplay=0; Electronic payment not included)

IWPAYAMT. Amount of Interview Payment

<input type="text" value="0.00"/>	(WtrPrePaid=1 & RPay4PP=1) or (((WtrPrePaid=1 & RPay4PP=2, 5) or (WtrPrePaid=5)) & RPay4A=4)
<input type="text" value="Payment (+ 10.00)"/>	WtrPrePaid=5 & RPay9A=1, 2 (+ cell phone if RPay9D=3)
<input type="text" value="RPay9c (+ RPay9c2)"/>	((WtrPrePaid=1 & RPay4PP=2, 5) or (WtrPrePaid=5)) & RPay9A=5 (+ cell phone)
<input type="text" value="RPay9dAmt (+ 10.00)"/>	((WtrPrePaid=1 & RPay4PP=2, 5) or (WtrPrePaid=5)) & RPay9A=7 & RPay9D=1, 4 (+ cell phone if RPay9D=3)

(AddrPayment.xEPDisplay=0; Electronic payment code 6 not included)

IWPAYMODE. Mode of Interview Payment

<input type="text" value="1. Check"/>	((WtrPrePaid=1 & RPay4PP=2, 5) or (WtrPrePaid=5)) & RPay9A=1 or RPay9D=1, 4
<input type="text" value="2. Money order"/>	WtrPrePaid=5 & RPay9A=2
<input type="text" value="4. Declined"/>	((WtrPrePaid=1 & RPay4PP=2, 5) or (WtrPrePaid=5)) & RPay4A=4
<input type="text" value="5. Cash"/>	((WtrPrePaid=1 & RPay4PP=2, 5) or (WtrPrePaid=5)) & RPay9A=5
<input type="text" value="7. None; Prepay okay"/>	WtrPrePaid=1 & RPay4PP=1

Locator 1 Contact Information

NOTE: Locator 1 data are pushed from SurveyTrak tsample_line_address into Blaise: vExt_032 (AddrPayment.RPay10a), stitle_long (AddrPayment.RPay10b.Title), vFirstName (AddrPayment.RPay10b.NamF), vMiddleName (AddrPayment.RPay10b.NamM), vLastName (AddrPayment.RPay10b.NamL), sSuffix (AddrPayment.RPay10b.Suffix), vInCareOf (AddrPayment.RPay10b.InCo), vAddressLine1 (AddrPayment.RPay10b.Addr1), vUSPS_Secondary_Address (AddrPayment.RPay10b.AptSte), vAddressLine2 (AddrPayment.RPay10b.Addr2), sCity (AddrPayment.RPay10b.City), sState (AddrPayment.RPay10b.State), sPostalCode (AddrPayment.RPay10b.Zip), sCountry (AddrPayment.RPay10b.Country), sPhone (AddrPayment.L1Phone.CellPh), vext_017 (AddrPayment.L1Phone.CellFor), sphone2 (AddrPayment.L1Phone.HomePh), vext_027 (AddrPayment.L1Phone.HomeFor), vRelationship (AddrPayment.RPay10gg), vExt_012 (AddrPayment.RPay10ggSpec), vExt_060 (AddrPayment.RPay10h), vExt_061 (AddrPayment.RPay10i)

RPAY10A. Interviewer Checkpoint

- Did you or any other interviewer offer a Locator Fee to get this interview?

→ GO TO RPAY12



ADDRPAYMENT.RPAY10B

<p>ADDRTYPE. Which Address</p> <p>6. Locator 1</p> <p>TITLE. Title -- e.g. "Mr", "Mrs", "Ms", "Miss", "Dr" Enter name and mailing address for Locator #1</p> <ul style="list-style-type: none"> If no title, PRESS [Enter] to continue Ctrl-D and Ctrl-R not allowed; For DK/RF, PRESS [Enter] to continue <p>String 6</p> <p>NAMF. First Name</p> <ul style="list-style-type: none"> Ctrl-D and Ctrl-R not allowed; For DK/RF type [DK] or [RF] <p>String 20</p> <p>NAMM. Middle Name</p> <ul style="list-style-type: none"> Ask for Middle Name but do not probe DK or RF If none, PRESS [Enter] to continue Ctrl-D and Ctrl-R not allowed; For DK/RF, PRESS [Enter] to continue <p>String 20</p> <p>NAML. Last Name</p> <ul style="list-style-type: none"> Ctrl-D and Ctrl-R not allowed; For DK/RF type [DK] or [RF] <p>String 20</p> <p>SUFFIX. Suffix -- e.g. "Sr", "Jr"</p> <ul style="list-style-type: none"> If none, PRESS [Enter] to continue Ctrl-D and Ctrl-R not allowed; For DK/RF, PRESS [Enter] to continue <p>String 20</p> <p>INCO. In Care Of</p> <ul style="list-style-type: none"> If none, PRESS [Enter] to continue Ctrl-D and Ctrl-R not allowed; For DK/RF, PRESS [Enter] to continue <p>String 40</p>	<p>ADDR1. Address 1</p> <ul style="list-style-type: none"> IF R says the mailing address contains both a street address and PO Box: ENTER street address here (Address 1) and ENTER PO Box in Address 2 Ctrl-D and Ctrl-R not allowed; For DK/RF type [DK] or [RF] <p>String 40</p> <p>APTSTE. Apt/Suite</p> <ul style="list-style-type: none"> If none, PRESS [Enter] to continue Ctrl-D and Ctrl-R not allowed; For DK/RF, PRESS [Enter] to continue <p>String 10</p> <p>ADDR2. Address 2</p> <ul style="list-style-type: none"> IF R says the mailing address contains both a street address and PO Box: ENTER PO Box here (Address 2) If none, PRESS [Enter] to continue Ctrl-D and Ctrl-R not allowed; For DK/RF, PRESS [Enter] to continue <p>String 40</p> <p>CITY. City</p> <ul style="list-style-type: none"> Ctrl-D and Ctrl-R not allowed; For DK/RF type [DK] or [RF] <p>String 40</p> <p>STATE. State</p> <ul style="list-style-type: none"> Start typing the name of the State to bring up the look-up list If foreign country, ENTER [FOR] to select "Foreign Country" <p>String 30; String 4</p> <p>ZIP. Zip Code</p> <ul style="list-style-type: none"> If foreign country, ENTER all [0]'s Ctrl-D and Ctrl-R not allowed; For DK/RF ENTER all [0]'s <p>-----</p> <p>COUNTRY. Country if different from USA</p> <ul style="list-style-type: none"> Start typing the name of the Foreign Country to bring up the look-up list <p>String 30; String 2</p>
---	---

END RPAY10B

SIGNAL for LOCATOR 1: IWER: Make sure that Helper/Locator's name and address are complete. Payments will NOT be made to incomplete names or addresses. If any field is Missing/DK/RF, SUSPEND the interview until you have the correct information.

ADDRPAYMENT.L1PHONE

<p>ADDRTYPE. Which Phone <input type="text" value="6. Locator 1"/></p> <p>WTRCELL. Does [RPAY10B.NAMF RPAY10B.NAML] have a cell phone? <ul style="list-style-type: none"> Ctrl-D and Ctrl-R not allowed; For DK/RF ENTER [5] <input type="text" value="1. Yes"/> <input type="text" value="5. No"/> → GO TO WTRHOME ↓</p> <p>CELLPH. Cell Phone - Area Code and Telephone Number What is the area code and phone number? <ul style="list-style-type: none"> If foreign phone, PRESS [ENTER] to go to foreign phone field Ctrl-D and Ctrl-R not allowed; For DK/RF, GO BACK and ENTER [5] at WtrCell <input type="text" value="[ENTER] (__)_--_--_"/> → GO TO WTRHOME ↓</p> <p>CELLFOR. Cell Phone - Foreign Number (What is the area code and phone number?) <ul style="list-style-type: none"> Ctrl-D and Ctrl-R not allowed; For DK/RF, GO BACK and ENTER [5] at WtrCell <input type="text" value="String 20"/></p>	<p>WTRHOME. Does [RPAY10B.NAMF RPAY10B.NAML] have a home phone? <ul style="list-style-type: none"> Ctrl-D and Ctrl-R not allowed; For DK/RF ENTER [5] <input type="text" value="1. Yes"/> <input type="text" value="5. No"/> → GO TO RPAY10GG ↓</p> <p>HOMEPH. Home Phone - Area Code and Telephone Number What is the area code and phone number? <ul style="list-style-type: none"> If foreign phone, PRESS [ENTER] to go to foreign phone field Ctrl-D and Ctrl-R not allowed; For DK/RF, GO BACK and ENTER [5] at WtrHome <input type="text" value="[ENTER] (__)_--_--_"/> → GO TO RPAY10GG ↓</p> <p>HOMEFOR. Home Phone - Foreign Number (What is the area code and phone number?) <ul style="list-style-type: none"> Ctrl-D and Ctrl-R not allowed; For DK/RF, GO BACK and ENTER [5] at WtrHome <input type="text" value="String 20"/></p>
---	---

END L1PHONE

RPAY10GG. What is (his/her) relationship to [REFERENCE PERSON]?

<input type="text" value="1. Mother"/>	<input type="text" value="2. Father"/>	<input type="text" value="3. Son"/>	<input type="text" value="4. Daughter"/>	<input type="text" value="5. Sister"/>	<input type="text" value="6. Brother"/>
<input type="text" value="7. Aunt"/>	<input type="text" value="8. Uncle"/>	<input type="text" value="9. Grandmother"/>	<input type="text" value="10. Grandfather"/>	<input type="text" value="11. Friend"/>	<input type="text" value="12. Father-in-law"/>
<input type="text" value="13. Mother-in-law"/>	<input type="text" value="14. Cousin"/>	<input type="text" value="97. Other-Specify (RPAY10GGSPEC. Specify. (String 50))"/>			

RPAY10H. How much did you offer Locator #1?

<input type="text" value="10. Ten dollars (\$10)"/>	<input type="text" value="15. Fifteen dollars (\$15)"/>	<input type="text" value="20. Twenty dollars (\$20) - with TL approval"/>
---	---	---

RPAY10I. Can Locator #1 be paid by check or did (he/she) request a money order?

<input type="text" value="1. Check"/>	<input type="text" value="2. Money Order"/>	<input type="text" value="3. Cash"/>	<input type="text" value="4. Declined Payment"/>	<input type="text" value="DK/RF"/>
GO TO RPAY11A		↓	GO TO RPAY11A	

RPAY10J. When was Locator #1 paid?

- ENTER MM/DD/[CYEAR], with or without slashes

Locator 2 Contact Information

NOTE: Locator 2 data are pushed from SurveyTrak tsample_line_address into Blaise: vExt_033 (AddrPayment.RPay11a), stitle_long (AddrPayment.RPay11b.Title), vFirstName (AddrPayment.RPay11b.NamF), vMiddleName (AddrPayment.RPay11b.NamM), vLastName (AddrPayment.RPay11b.NamL), sSuffix (AddrPayment.RPay11b.Suffix), vInCareOf (AddrPayment.RPay11b.InCo), vAddressLine1 (AddrPayment.RPay11b.Addr1), vUSPS_Secondary_Address (AddrPayment.RPay11b.AptSte), vAddressLine2 (AddrPayment.RPay11b.Addr2), sCity (AddrPayment.RPay11b.City), sState (AddrPayment.RPay11b.State), sPostalCode (AddrPayment.RPay11b.Zip), sCountry (AddrPayment.RPay11b.Country), sPhone (AddrPayment.L2Phone.CellPh), vext_017 (AddrPayment.L2Phone.CellFor), sphone2 (AddrPayment.L2Phone.HomePh), vext_027 (AddrPayment.L2Phone.HomeFor), vext_008 (AddrPayment.L2Phone.OthExt), vRelationship (AddrPayment.RPay11gg), vExt_012 (AddrPayment.RPay11ggSpec), vExt_062 (AddrPayment.RPay11h), vExt_063 (AddrPayment.RPay11i)

RPAY11A. Interviewer Checkpoint

- Was there a second Locator Fee offered for this interview?

1. Yes | 5. No → GO TO RPAY12



ADDRPAYMENT.RPAY11B

<p>ADDRTYPE. Which Address</p> <p>7. Locator 2</p> <p>TITLE. Title -- e.g. "Mr", "Mrs", "Ms", "Miss", "Dr" Enter name and mailing address for Locator #2</p> <ul style="list-style-type: none"> If no title, PRESS [Enter] to continue Ctrl-D and Ctrl-R not allowed; For DK/RF, PRESS [Enter] to continue <p>String 6</p> <p>NAMF. First Name</p> <ul style="list-style-type: none"> Ctrl-D and Ctrl-R not allowed; For DK/RF type [DK] or [RF] <p>String 20</p> <p>NAMM. Middle Name</p> <ul style="list-style-type: none"> Ask for Middle Name but do not probe DK or RF If none, PRESS [Enter] to continue Ctrl-D and Ctrl-R not allowed; For DK/RF, PRESS [Enter] to continue <p>String 20</p> <p>NAML. Last Name</p> <ul style="list-style-type: none"> Ctrl-D and Ctrl-R not allowed; For DK/RF type [DK] or [RF] <p>String 20</p> <p>SUFFIX. Suffix -- e.g. "Sr", "Jr"</p> <ul style="list-style-type: none"> If none, PRESS [Enter] to continue Ctrl-D and Ctrl-R not allowed; For DK/RF, PRESS [Enter] to continue <p>String 20</p> <p>INCO. In Care Of</p>	<p>ADDR1. Address 1</p> <ul style="list-style-type: none"> If R says the mailing address contains both a street address and PO Box: ENTER street address here (Address 1) and ENTER PO Box in Address 2 Ctrl-D and Ctrl-R not allowed; For DK/RF type [DK] or [RF] <p>String 40</p> <p>APTSTE. Apt/Suite</p> <ul style="list-style-type: none"> If none, PRESS [Enter] to continue Ctrl-D and Ctrl-R not allowed; For DK/RF, PRESS [Enter] to continue <p>String 10</p> <p>ADDR2. Address 2</p> <ul style="list-style-type: none"> If R says the mailing address contains both a street address and PO Box: ENTER PO Box here (Address 2) If none, PRESS [Enter] to continue Ctrl-D and Ctrl-R not allowed; For DK/RF, PRESS [Enter] to continue <p>String 40</p> <p>CITY. City</p> <ul style="list-style-type: none"> Ctrl-D and Ctrl-R not allowed; For DK/RF type [DK] or [RF] <p>String 40</p> <p>STATE. State</p> <ul style="list-style-type: none"> Start typing the name of the State to bring up the look-up list If foreign country, ENTER [FOR] to select "Foreign Country" <p>String 30; String 4</p> <p>ZIP. Zip Code</p>
---	---

<p>Is there an "in care of" for this address?</p> <ul style="list-style-type: none"> If none, PRESS [Enter] to continue Ctrl-D and Ctrl-R not allowed; For DK/RF, PRESS [Enter] to continue <p>String 40</p>	<ul style="list-style-type: none"> If foreign country, ENTER all [0]'s Ctrl-D and Ctrl-R not allowed; For DK/RF ENTER all [0]'s <p>-----</p> <p>COUNTRY. Country if different from USA</p> <ul style="list-style-type: none"> Start typing the name of the Foreign Country to bring up the look-up list <p>String 30; String 2</p>
--	---

END RPAY11B

SIGNAL for LOCATOR 2: IWER: Make sure that Helper/Locator's name and address are complete. Payments will NOT be made to incomplete names or addresses. If any field is Missing/DK/RF, SUSPEND the interview until you have the correct information.

ADDRPAYMENT.L2PHONE

<p>ADDRTYPE. Which Phone</p> <p>7. Locator 2</p> <p>WTRCELL. Does [RPAY11B.NAMF RPAY11B.NAML] have a cell phone?</p> <ul style="list-style-type: none"> Ctrl-D and Ctrl-R not allowed; For DK/RF ENTER [5] <p>1. Yes 5. No → GO TO WTRHOME</p> <p>↓</p> <p>CELLPH. Cell Phone - Area Code and Telephone Number</p> <p>What is the area code and phone number?</p> <ul style="list-style-type: none"> If foreign phone, PRESS [ENTER] to go to foreign phone field Ctrl-D and Ctrl-R not allowed; For DK/RF, GO BACK and ENTER [5] at WtrCell <p>[ENTER] (____)____-_____ → GO TO WTRHOME</p> <p>↓</p> <p>CELLFOR. Cell Phone - Foreign Number</p> <p>(What is the area code and phone number?)</p> <ul style="list-style-type: none"> Ctrl-D and Ctrl-R not allowed; For DK/RF, GO BACK and ENTER [5] at WtrCell <p>String 20</p>	<p>WTRHOME. Does [RPAY11B.NAMF RPAY11B.NAML] have a home phone?</p> <ul style="list-style-type: none"> Ctrl-D and Ctrl-R not allowed; For DK/RF ENTER [5] <p>1. Yes 5. No → GO TO RPAY11GG</p> <p>↓</p> <p>HOMEPH. Home Phone - Area Code and Telephone Number</p> <p>What is the area code and phone number?</p> <ul style="list-style-type: none"> If foreign phone, PRESS [ENTER] to go to foreign phone field Ctrl-D and Ctrl-R not allowed; For DK/RF, GO BACK and ENTER [5] at WtrHome <p>[ENTER] (____)____-_____ → GO TO RPAY11GG</p> <p>↓</p> <p>HOMEFOR. Home Phone - Foreign Number</p> <p>(What is the area code and phone number?)</p> <ul style="list-style-type: none"> Ctrl-D and Ctrl-R not allowed; For DK/RF, GO BACK and ENTER [5] at WtrHome <p>String 20</p>
---	--

END L2PHONE

RPAY11GG. What is (his/her) relationship to [REFERENCE PERSON]?

1. Mother	2. Father	3. Son	4. Daughter	5. Sister	6. Brother
7. Aunt	8. Uncle	9. Grandmother	10. Grandfather	11. Friend	12. Father-in-law
13. Mother-in-law	14. Cousin	97. Other-Specify (RPAY11GGSPEC. Specify. (String 50))			

RPAY11H. How much did you offer Locator #2?

10. Ten dollars (\$10)	15. Fifteen dollars (\$15)	20. Twenty dollars (\$20) - with TL approval
------------------------	----------------------------	--

RPAY11I. Can Locator #2 be paid by check or did (he/she) request a money order?

1. Check	2. Money Order	3. Cash	4. Declined payment	DK/RF
GO TO RPAY12		↓	GO TO RPAY12	

RPAY11J. When was Locator #2 paid?

- ENTER MM/DD/[CYEAR], with or without slashes

Payment Problems

RPAY12. Were there any Respondent or Locator payment problems reported by this Respondent?

 → GO TO IW END SECTION

RPAY12SPEC. Please provide details of payment issue.

END ADDRPAYMENT

Interview End

[TOC](#)

IWCOMPLETE. You have reached the end of the Interview.

- ENTER [1] to complete.

IWPARTIAL. Is this a Completed interview or an [approved](#) Partial interview?

- ENTER [0] for a COMPLETED interview
- ENTER [1005] for a PARTIAL interview

SIGNAL for IWPARTIAL=1005: IWER: Are you sure that this is an APPROVED Partial interview? If you have approval from your TL to make this a Partial interview, click Suppress to continue. Otherwise, if this is a Completed interview, click Close and ENTER [0].