

1988

P. 23 (457723)

For Office Use Only

THE STUDY OF FAMILY ECONOMICS

SURVEY RESEARCH CENTER
 INSTITUTE FOR SOCIAL RESEARCH
 THE UNIVERSITY OF MICHIGAN
 ANN ARBOR, MICHIGAN 48106

1. INTERVIEWER'S LABEL

V15125

2. Your Iw. No. V15126 3. Iw. Date V15127 4. Iw. Length V15128 MINUTES5. Post-edit Length MINUTES6. 68-87 ID# -

<input type="text"/> V15105	<input type="text"/> V15106	<input type="text"/> V15107
68 ID	69 ID	70 ID
<input type="text"/> V15108	<input type="text"/> V15109	<input type="text"/> V15110
71 ID	72 ID	73 ID
<input type="text"/> V15111	<input type="text"/> V15112	<input type="text"/> V15113
74 ID	75 ID	76 ID
<input type="text"/> V15114	<input type="text"/> V15115	<input type="text"/> V15116
77 ID	78 ID	79 ID
<input type="text"/> V15117	<input type="text"/> V15118	<input type="text"/> V15119
80 ID	81 ID	82 ID
<input type="text"/> V15120	<input type="text"/> V15121	<input type="text"/> V15122
83 ID	84 ID	85 ID
<input type="text"/> V15123	<input type="text"/> V15124	
86 ID	87 ID	

For Office Use Only

REVIEWED:

 BY SUPERVISOR _____ (DATE) BY FIELD OFFICE _____ (DATE)

For Office Use Only

BEFORE YOU BEGIN:

For REINTERVIEW families, affix 1987 OFUM label to G71 grid, p. 61, if there is such a label stapled to p. 2 of the cover sheet.

THUMBNAIL SKETCH

REMEMBER: NO NAMES OR OTHER IDENTIFYING INFORMATION MAY BE WRITTEN IN QUESTIONNAIRE!

*TN1. Who was your Respondent? VI6128
 RELATIONSHIP TO HEAD _____

*TN2. Total number of calls required to obtain interview (see item 10 of Reinterview Cover Sheet or item 11 of Splitoff Cover Sheet):
VI6129

TN3. Are there people living in this household unit (HU) who are not included in this family unit (FU)?

YES NO → GO TO TN4

Explain situation: _____

TN4. Please provide a few words about this FU which might help editors and coders understand any potentially confusing family situations or relationships (such as the fact that parents of grandchildren do not live in HU, who the actual parents of stepchildren and grandchildren are, etc.):

TN5. Elaborate on any ambiguous or conflicting information in this interview that you want editors and coders to know about:

TN6. How would you describe the interview situation? Please add any other clarifying remarks that will be helpful to editors and coders when this interview is processed. If this FU should be recontacted for missing information from Ann Arbor, is there something else we should be aware of?

SECTION A: MARITAL STATUS, HOUSING AND TRANSPORTATION

A1. INTERVIEWER CHECKPOINT: SEE REINTERVIEW COVER SHEET, (P. 2)--ITEMS 14a AND 17a OR SPLITOFF COVER SHEET, (P. 2)--ITEM 13f

A. ALL HU MEMBERS ARE FU MEMBERS

B. ONE OR MORE HU MEMBERS ARE NOT FU MEMBER(S) BECAUSE:

a. HAVE OWN COVER SHEET(S)
 b. LIVING WITH THIS FU ONLY TEMPORARILY
 c. OTHER (SPECIFY): _____

↓

INFORM R THAT THESE PERSONS ARE NOT TO BE INCLUDED IN INTERVIEW

A2. TIME START: _____

*A3. Are you (HEAD) married, widowed, divorced, separated, or have you never been married?
 V15136

- | | | | | |
|------------|------------|-----------------------|--------------|------------------|
| 1. MARRIED | 3. WIDOWED | 4. DIVORCED, ANNULLED | 5. SEPARATED | 2. NEVER MARRIED |
|------------|------------|-----------------------|--------------|------------------|

*A4. Do you live in a one-family house, a two-family house, an apartment, a mobile home, or what?
 V15137 [IF R ANSWERS "CONDO," PROBE FOR TYPE OF DWELLING]

- | | | | | |
|---------------|-----------------------|--------------|----------------|--------------------------|
| 1. ONE-FAMILY | 2. TWO-FAMILY; DUPLEX | 3. APARTMENT | 4. MOBILE HOME | 6. ROW HOUSE; TOWN HOUSE |
|---------------|-----------------------|--------------|----------------|--------------------------|

7. OTHER (SPECIFY): _____

*A5. How many rooms do you have (for your family) not counting bathrooms?

VI5138 ROOMS

*A6. There are government programs that give money to people to help them pay for heating their homes. Did you receive help with heating bills from any government program last winter (1987-1988)?
 V15139

1. YES 5. NO → NEXT PAGE, A8

A7. About how much did that amount to altogether? \$ VI4828 PER _____
 (Edited)

*A8. Do you own the (home/apartment), pay rent, or what?
V15140

1. ANY FU MEMBER OWNS OR IS BUYING	5. FU PAYS RENT GO TO A13	8. FU NEITHER OWNS NOR RENTS NEXT PAGE, A15
------------------------------------	------------------------------	--

A9. Could you tell me what the present value of your (house/apartment/farm) is--
mean about how much would it bring if you sold it today?
\$ V14824 (Edited) HOUSE VALUE

*A10. Do you have a mortgage on this property?
V15141

1. YES: MORTGAGE, LAND CONTRACT, OR DEED OF TRUST	5. NO → NEXT PAGE, A18
---	------------------------

1st MORTGAGE	2nd MORTGAGE
A11. About how much is the remaining principal on this mortgage?	
\$ V14826 (Edited) OR DK	\$ _____ OR DK NEXT PAGE, A18
A12. Do you have a second mortgage? V15142	
1. YES → ASK A11 AGAIN	5. NO → NEXT PAGE, A18

IF FU PAYS RENT

*A13. Is this (house/apartment) in a public housing project, that is, is it
V15143 owned by a local housing authority or other public agency?

1. YES → NEXT PAGE, A18	5. NO
-------------------------	-------

*A14. Are you paying lower rent because the Federal, State, or local
V15144 government is paying part of the cost? [COST OF RENT]

1. YES	5. NO
--------	-------

NEXT PAGE, A18

IF FU NEITHER OWNS NOR RENTS

*A15. How is that? V15145 _____

*A16. Is this (house/apartment) in a public housing project, that is, is it owned by
V15146 a local housing authority or other public agency?

1. YES → GO TO A18	5. NO
--------------------	-------

*A17. Are you paying no rent because the Federal, State, or local
V15147 government is paying all of it?

1. YES	5. NO
--------	-------

*A18. Have you (HEAD) moved any time since the spring of 1987?
V15148

1. YES	5. NO → GO TO A21
--------	-------------------

*A19. What month and year was that? (MOST RECENT MOVE)

V15149
MONTH YEAR

*A20. Why did you (HEAD) move? V15150 _____

*A21. Do you think you (HEAD) might move in the next couple of years?
V15151

1. YES, MIGHT OR MAYBE	5. NO	8. DON'T KNOW
------------------------	-------	---------------

NEXT PAGE, SECTION B

*A22. Would you say you definitely will move, probably will move, or are you
V15152 more uncertain?

1. DEFINITELY	2. PROBABLY	3. MORE UNCERTAIN
---------------	-------------	-------------------

*A23. Why (will/might) you move? V15153 _____

SECTION B: EMPLOYMENT OF HEAD

*B1. We would like to know about what you do--are you (HEAD) working now, looking for work, retired, keeping house, a student, or what?
V15154

[IF R MENTIONS CODES 1-3, CHECK ONE AND ONLY ONE BOX, AND NONE FROM 4-8]

1. WORKING NOW	2. ONLY TEMPORARILY LAID OFF, SICK LEAVE OR MATERNITY LEAVE	3. LOOKING FOR WORK, UNEMPLOYED
----------------	---	---------------------------------

NEXT PAGE, B4

[IF R MENTIONS ONLY CODES 4-8, CHECK AS MANY AS APPLY]

4. RETIRED	*B2. In what year did you (HEAD) retire? V15155	V15156 *B3. Are you (HEAD) doing <u>any</u> work for money now at all? 1. YES 5. NO NEXT PAGE, B4 TURN TO P. 17, SECTION C
5. PERMANENTLY DISABLED		
6. KEEPING HOUSE		
7. STUDENT		
8. OTHER (SPECIFY):		

*B4. On your main job, are you (HEAD) self-employed, are you employed by someone else, or what?
V15157

3. SELF-EMPLOYED ONLY	2. BOTH SOMEONE ELSE AND SELF	1. SOMEONE ELSE ONLY
-----------------------	-------------------------------	----------------------

V15158

*B5. Is that an unincorporated business or a corporation?

1. UNINCORPORATED
2. CORPORATION

V15159

*B6. Do you (HEAD) work for the federal, state, or local government, a private company, or what?

1. FEDERAL GOV'T	2. STATE GOV'T	3. LOCAL GOV'T
4. PRIVATE NON-GOV'T	9. DON'T KNOW	
7. OTHER (SPECIFY): _____		

*B7. Is your current job covered by a union contract?
V15160

1. YES	5. NO → GO TO B9
--------	------------------

*B8. Do you belong to that labor union?
V15161

1. YES	5. NO
--------	-------

*B9. What is your (HEAD'S) main occupation? What sort of work do you do?

V15162 V15163
 • [] [] [] • [] [] []
 OCC IND

B10. What are your most important activities or duties?

B11. What kind of business or industry is that in?

*B12. (On your main job,) are you (HEAD) salaried, paid by the hour, or what?
V15164

1. SALARIED

3. PAID BY HOUR

7. OTHER

*B13. How much is your salary?
\$ _____ PER WEEK
OR
\$ _____ PER MONTH
OR
\$ _____ PER YEAR
V15165
*REG

*B14. If you were to work more hours than usual during some week, would you get paid for those extra hours of work?
V15166

1. YES

5. NO

NEXT PAGE, B20

*B15. About how much would you make per hour for those extra hours?
\$ _____ PER HOUR

TIME AND A HALF

DOUBLE TIME

*OT

V15167
NEXT PAGE, B20

*B16. What is your hourly wage rate for your regular work time?
\$ _____ PER HOUR
*REG

V15168

*B17. What is your hourly wage rate for overtime?
\$ _____ PER HOUR

TIME AND A HALF

DOUBLE TIME

OTHER (SPECIFY):

*OT

V15169

NEXT PAGE, B20

*B18. How is that?
V15170

*B19. If you worked an extra hour, how much would you earn for that hour?
\$ _____ PER HOUR

*OT

V15171

NEXT PAGE, B20

*B20. Have you (HEAD) been looking for another job during the past four weeks?

V15172

1. YES

5. NO → GO TO B22

*B21. What have you been doing the last four weeks to find another job? [CHECK ALL THAT APPLY]

V15174 A. CHECKED WITH PUBLIC EMPLOYMENT AGENCY

NOTHING

V15173

V15175 B. CHECKED WITH PRIVATE EMPLOYMENT AGENCY

V15176 C. CHECKED WITH CURRENT EMPLOYER DIRECTLY

V15177 D. CHECKED WITH OTHER EMPLOYER DIRECTLY

V15178 E. CHECKED WITH FRIENDS OR RELATIVES

V15179 F. PLACED OR ANSWERED ADS

V15180 G. OTHER (SPECIFY):

B22. INTERVIEWER CHECKPOINT

SEE B4, (P. 5)--WHETHER SELF-EMPLOYED

A. HEAD WORKS FOR SOMEONE ELSE *ONLY*

B. ALL OTHERS → NEXT PAGE, B24

*B23. How many years' experience do you (HEAD) have altogether with your present employer?

V15181

MOS

_____ MONTHS *OR* _____ YEARS

*B24. In what month and year did you start working for your present employer? (Count yourself as the employer if you are self-employed, and) give us your most recent start date if you have gone to work for them more than once. [IF NECESSARY: What would be your best guess? Did you start before 1987?]

V15182
MONTH DAY [IF VOLUNTEERED]

V15183
1987 1988 96. 1987 OR 1988, DK WHICH OTHER YEAR: 97. BEFORE 1987, DK EXACT YEAR 98. DK YEAR AT ALL

V15184

*B25. Is that when you started working in your present (position/work situation)?
1. YES 5. NO
NEXT PAGE, B37

*B30. In what month and year did you start working in your present (position/work situation)?
V15190 MONTH DAY [IF VOLUNTEERED] 1987 1988
V15191
NEXT PAGE, B40

*B31. In what month and year did you start working in your present (position/work situation)?
V15192 MONTH DAY [IF VOLUNTEERED] 1987 1988 OTHER YEAR: V15193
GO TO B34
NEXT PAGE, B39

*B26. In what month and year did you start working in your present (position/work situation)?
V15185 MONTH DAY [IF VOLUNTEERED] 1987 1988
V15186
1987 → GO TO B29 1988

*B27. Did you change (positions/work situations) with this employer at any time during 1987?
1. YES 5. NO → NEXT PAGE, B35

*B28. In what month did that happen?
V15188 MONTH

*B29. Was that a promotion with higher pay, a major change in your duties but with the same pay, or what?
V15189

NEXT PAGE, B35

*B32. Did you change (positions/work situations) with this employer at any time during 1987?
1. YES 5. NO → NEXT PAGE, B39

V15194

*B33. In what month did that happen?
V15195 MONTH

*B34. Was that a promotion with higher pay, a major change in your duties but with the same pay, or what?
V15196

NEXT PAGE, B39

*B35. What was your (HEAD'S) occupation when you started working for that employer during 1987? What sort of work did you do?

V15197
OCC

*B36. What were your most important activities or duties?

*B37. What was your starting salary or wage at that time?

\$ _____ PER _____
V15198 RATE

*B38. And how many hours a week did you work when you started?

V15199 HOURS PER WEEK

*B39. In which months during 1987 were you working for that employer as your main job?

ALL OR JAN FEB MAR APR MAY JUNE JULY AUG SEPT OCT NOV DEC
V15200-V15211

*B40. Did you have any (other) main-job employers at any time during 1987? Again, if you were self-employed on a main job, count yourself as an employer.

1. YES 5. NO → TURN TO P. 12, B60

*B41. In what month and year did you start working for that (other) main-job employer?

V15213 YEAR: V15214 97. BEFORE 1987, DK EXACT YEAR 98. DK YEAR AT ALL
MONTH DAY [IF VOLUNTEERED]

*B42. In which months during 1987 were you working for that employer?

ALL OR JAN FEB MAR APR MAY JUNE JULY AUG SEPT OCT NOV DEC
V15215-V15226

*B43. On this main job, were you (HEAD) self-employed, were you employed by someone else, or what?
V15227

- 3. SELF-EMPLOYED ONLY
- 2. BOTH SOMEONE ELSE AND SELF
- 1. SOMEONE ELSE ONLY

V15228 *B44. Was that an unincorporated business or a corporation?

- 1. UNINCORPORATED
- 2. CORPORATION

V15229 *B45. Did you (HEAD) work for the federal, state, or local government, a private company, or what?

- 1. FEDERAL GOV'T
- 2. STATE GOV'T
- 3. LOCAL GOV'T
- 4. PRIVATE NON-GOV'T
- 9. DON'T KNOW
- 7. OTHER (SPECIFY): _____

*B46. What was your occupation when you first started working for them? What sort of work did you do?

_____ V15230

 •
 OCC

B47. What were your most important activities or duties?

*B48. What kind of business or industry was that in?

_____ V15231

 •
 IND

*B49. What was your starting wage or salary with that employer?

\$ _____ PER _____ V15232
 •
 RATE

*B50. And how many hours a week did you work when you first started?

V15233 _____ HOURS PER WEEK

*B51. During 1987, did your job title or position with that employer change?
V15234

- 1. YES
- 5. NO → GO TO B54

*B52. In what month did that happen?

V15235 _____
 MONTH

*B53. Was that a promotion with higher pay, a major change in your duties but with the same pay, or what?

V15236 _____

*B54. Have you stopped working for that employer?
V15237

- 1. YES
- 5. NO → GO TO B59

*B55. In what month and year did you stop working for that employer?

1987 1988 98. 1987 or 1988, DR WHICH

V15238 _____ V15239 _____
 MONTH DAY [IF VOLUNTEERED]

*B56. What happened with that employer--did the company go out of business, were you (HEAD) laid off, did you quit, or what?

V15240 _____

*B57. What was your (HEAD'S) final wage or salary when you left that employer?

\$ _____ PER _____ V15241 •
 RATE

*B58. And how many hours a week did you work just before you left?

V15242 _____ HOURS PER WEEK

*B59. Did you have any other main-job employers at any time during 1987? (Remember to count yourself as an employer if you were self-employed then on a main job.)

V15243 1. YES 5. NO → NEXT PAGE, B60
 TURN TO PINK WORK HISTORY SUPPLEMENT NUMBER OF ADDITIONAL WORK HISTORY SPELLS=V15244

CONVERSION TABLE: WEEK EQUIVALENTS

DAYS TO WEEKS (BASED ON 5-DAY WORK WEEK)		MONTHS TO WEEKS	
1 DAY = .2 WEEKS	1 MONTH = 4.3 WEEKS	2 MONTHS = 8.6 WEEKS	
2 DAYS = .4 WEEKS	3 MONTHS = 13.0 WEEKS	4 MONTHS = 17.3 WEEKS	
3 DAYS = .6 WEEKS	5 MONTHS = 21.6 WEEKS	6 MONTHS = 26.0 WEEKS	
4 DAYS = .8 WEEKS	7 MONTHS = 30.3 WEEKS	8 MONTHS = 34.6 WEEKS	
5 DAYS = 1.0 WEEKS	9 MONTHS = 39.0 WEEKS	10 MONTHS = 43.3 WEEKS	
	11 MONTHS = 47.6 WEEKS	12 MONTHS = 52.0 WEEKS	

*B60. We're interested in how you (HEAD) spent your time from January through December 1987. I know you may have given me some of this information already, but my instructions are to ask these questions of everybody. Did you miss any work in 1987 because someone else was sick?
V15245

1. YES 5. NO → GO TO B63

*B61. How much work did you miss?
_____ DAYS V15246 WEEKS _____ MONTHS
B62. When was that? TOTAL ANNUAL HOURS=Edited V14836

*B63. Did you miss any work in 1987 because you were sick?
V15247

1. YES 5. NO → GO TO B66

*B64. How much work did you miss?
_____ DAYS V15248 WEEKS _____ MONTHS
B65. When was that? TOTAL ANNUAL HOURS=Edited V14838

*B66. Did you take any vacation or time off during 1987?
V15249

1. YES 5. NO → NEXT PAGE, B69

*B67. How much vacation or time off did you take?
_____ DAYS V15250 WEEKS _____ MONTHS
B68. When was that? [GET DAY IF VOLUNTEERED]
FROM _____ THRU _____ FROM _____ THRU _____

FOR IWER
CALCULATIONS
ONLY

*B69. Did you miss any work in 1987 because you were on strike?
V15251

1. YES 5. NO → GO TO B72

*B70. How much work did you miss?
_____ DAYS V15252 WEEKS _____ MONTHS

B71. When was that? [GET DAY IF VOLUNTEERED]
FROM _____ THRU _____ FROM _____ THRU _____
TOTAL ANNUAL HOURS=Edited V14840

*B72. Did you miss any work in 1987 because you were unemployed and looking for work or temporarily laid off?
V15253

1. YES 5. NO → GO TO B75

*B73. How much work did you miss?
_____ DAYS V15254 WEEKS _____ MONTHS

B74. When was that? [GET DAY IF VOLUNTEERED]
FROM _____ THRU _____ FROM _____ THRU _____
TOTAL ANNUAL HOURS=Edited V14842

*B75. Were there any weeks in 1987 when you didn't have a job and were not looking for one?
V15255

1. YES 5. NO → GO TO B78

*B76. How much time was that?
_____ DAYS V15256 WEEKS _____ MONTHS

B77. When was that? [GET DAY IF VOLUNTEERED]
FROM _____ THRU _____ FROM _____ THRU _____
TOTAL ANNUAL HOURS=Edited V14844

*B78. Then, how many weeks did you actually work on your main job(s) in 1987?

V15257 WEEKS IN 1987 00. DID NOT WORK AT ALL IN 1987
NEXT PAGE, B82

ALL THE REST ANNUAL WORK HOURS ON MAIN JOB=Edited V14829

IF TOTAL DOES NOT EQUAL 52 WEEKS OR 12 MONTHS, RECONCILE WITH R OR EXPLAIN BELOW:
TOTAL ANNUAL WORK HOURS=Edited V14835

*B79. And, on the average, how many hours a week did you work on your main job(s) in 1987?
V15258 HOURS PER WEEK IN 1987

*B80. Did you work any overtime which isn't included in that?
V15259

1. YES 5. NO → NEXT PAGE, B82

B81. How many hours did that overtime amount to in 1987?
V14831 (Edited) TOTAL OVERTIME HOURS IN 1987

TOTAL NUMBER OF EXTRA JOBS=V15261

*B82. Did you (HEAD) have an extra job or other way of making money in addition to your V15260 main job(s) in 1987?

1. YES 5. NO → TURN TO P. 28, SECTION D

*B83. Did you (HEAD) work for the federal, state, or local government, a private V15262 company, or what?

1. FEDERAL GOV'T 2. STATE GOV'T 3. LOCAL GOV'T 4. PRIVATE NON-GOV'T 9. DON'T KNOW 7. OTHER (SPECIFY):

*B84. What was your occupation? What sort of work did you do?
 _____ V15263
 •
 OCC

B85. What were your most important activities or duties?

*B86. What kind of business or industry was that in?
 _____ V15264
 •
 IND

*B87. About how much did you make at this?
 \$ _____ PER _____ V15265
 •
 RATE

*B88. And, how many weeks did you work on this job in 1987?
 V15266

WEEKS IN 1987
 ANNUAL WORK HOURS ON EXTRA JOBS=Edited V14833

*B89. On the average, how many hours a week did you work on this job?
 V15267

 HOURS PER WEEK IN 1987

*B90. In what month and year did you start working for that employer?

V15268 V15269
 MONTH YEAR

*B91. In which months during 1987 were you working for that employer?

V15270- V15281 ALL OR JAN FEB MAR APR MAY JUNE JULY AUG SEPT OCT NOV DEC

*B92. Have you stopped working for that employer?
 V15282

1. YES 5. NO → NEXT PAGE, B94

*B93. In what month and year was that?

V15283 V15284
 MONTH DAY [IF VOLUNTEERED] 1987 1988 98. 1987 or 1988, DK WHICH

B94. Did you have any other extra jobs in 1987?

YES NO → TURN TO P. 28, SECTION D

*B95. Did you (HEAD) work for the federal, state, or local local government, a V15285 private company, or what?

1. FEDERAL GOV'T 2. STATE GOV'T 3. LOCAL GOV'T 4. PRIVATE NON-GOV'T 9. DON'T KNOW 7. OTHER (SPECIFY):

*B96. What was your occupation? What sort of work did you do?
 _____ V15286
 •
 OCC

B97. What were your most important activities or duties?

*B98. What kind of business or industry was that in?
 _____ V15287
 •
 IND

*B99. About how much did you make at this?
 \$ _____ PER _____ V15288
 •
 RATE

*B100. And, how many weeks did you work on this job in 1987?
 V15289

 WEEKS IN 1987

*B101. On the average, how many hours a week did you work on this job?
 V15290

 HOURS PER WEEK IN 1987
 ANNUAL WORK HOURS ON EXTRA JOBS=Edited V14833

*B102. In what month and year did you start working for that employer?
 V15291 V15292
 MONTH YEAR

*B103. In which months during 1987 were you working for that employer?

V15293- V15304 ALL OR JAN FEB MAR APR MAY JUNE JULY AUG SEPT OCT NOV DEC

*B104. Have you stopped working for that employer?
 V15305

1. YES 5. NO → GO TO B106

*B105. In what month and year was that?

V15306 V15307
 MONTH DAY [IF VOLUNTEERED] 1987 1988 98. 1987 or 1988, DK WHICH

B106. Did you have any other extra jobs in 1987?

YES NO → TURN TO P. 28, SECTION D

ASK B95-B106 AGAIN

SECTION C: HEAD IS NOT WORKING NOW ["NO" TO B3, (P. 4)]

*C1. Have you (HEAD) been looking for work during the past four weeks?
V15308

1. YES

5. NO →NEXT PAGE, C4

THIS IS A BLANK PAGE!

*C2. What have you been doing the last four weeks to find work?
[CHECK ALL THAT APPLY]

A. CHECKED WITH PUBLIC EMPLOYMENT AGENCY

V15310

NOTHING

V15309

B. CHECKED WITH PRIVATE EMPLOYMENT AGENCY

V15311

C. CHECKED WITH PREVIOUS EMPLOYER DIRECTLY

V15312

D. CHECKED WITH OTHER EMPLOYER DIRECTLY

V15313

E. CHECKED WITH FRIENDS OR RELATIVES

V15314

F. PLACED OR ANSWERED ADS

V15315

G. OTHER (SPECIFY): _____

V15316

*C3. How long have you been looking for work?

V15317

•	

WKS

*C4. Have you (HEAD) ever done any work for money?
V15318

1. YES 5. NO → GO TO C6

*C5. In what month and year did you last work? [IF NECESSARY: What would be your best guess? Did you last work before 1987?]

V15320

V15319

MONTH DAY [IF VOLUNTEERED]

1987 1988 96. 1987 OR 1988, DK WHICH OTHER YEAR: 97. BEFORE 1987, DK EXACT YEAR 98. DK YEAR AT ALL

V15321

*C6. Were there any times in 1987 when you were looking for work?
1. YES 5. NO → TURN TO P. 28, SECTION D

*C7. How many weeks was that? V15322 OR 52. ALL

C8. When was that? FROM THRU TURN TO P. 28, SECTION D

*C9. What was your occupation on your last job? What sort of work did you do?

• V15323 • V15324
OCC IND

C10. What were your most important activities or duties? _____

C11. What kind of business or industry was that in? _____

*C12. On this main job, were you (HEAD) self-employed, were you employed by someone else, or what?
V15325

3. SELF-EMPLOYED ONLY 2. BOTH SOMEONE ELSE AND SELF 1. SOMEONE ELSE ONLY

V15326

*C13. Was that an unincorporated business or a corporation?
1. UNINCORPORATED
2. CORPORATION

V15327

*C14. Did you (HEAD) work for the federal, state, or local government, a private company, or what?
1. FEDERAL GOV'T 2. STATE GOV'T 3. LOCAL GOV'T
4. PRIVATE NON-GOV'T 9. DON'T KNOW
7. OTHER (SPECIFY): _____

*C15. What happened with that employer--did the company go out of business, were you (HEAD) laid off, did you quit, or what?

V15328

*C16. In what month and year did you start working for your last employer? (Count yourself as the employer if you were self-employed, and) give us your most recent start date if you went to work for them more than once. [IF NECESSARY: What would be your best guess? Did you start before 1987?]

V15330

V15329

MONTH DAY [IF VOLUNTEERED]

1987 1988 96. 1987 OR 1988, DK WHICH OTHER YEAR: 97. BEFORE 1987, DK EXACT YEAR 98. DK YEAR AT ALL

V15331

*C17. Is that when you started working in your last (position/work situation)?

1. YES 5. NO

NEXT PAGE, C29

*C22. In what month and year did you start working in your last (position/work situation)?

V15337 MONTH DAY [IF VOLUNTEERED]

V15338 1987 1988 OTHER YEAR: V15340

GO TO C26

NEXT PAGE, C32

*C23. In what month and year did you start working in your last (position/work situation)?

V15339 MONTH DAY [IF VOLUNTEERED]

1987 1988 OTHER YEAR: V15340

GO TO C26

NEXT PAGE, C31

*C18. In what month and year did you start working in your last (position/work situation)?

V15332 MONTH DAY [IF VOLUNTEERED]

V15333 1987 → GO TO C21 1988

*C19. Did you change (positions/work situations) with this employer at any time during 1987?

V15334

1. YES 5. NO → NEXT PAGE, C27

*C20. In what month did that happen?

V15335 MONTH

*C21. Was that a promotion with higher pay, a major change in your duties but with the same pay, or what?

V15336

NEXT PAGE, C27

*C24. Did you change (positions/work situations) with this employer at any time during 1987?

V15341 1. YES 5. NO → NEXT PAGE, C31

*C25. In what month did that happen?

V15342 MONTH

*C26. Was that a promotion with higher pay, a major change in your duties but with the same pay, or what?

V15343

NEXT PAGE, C31

*C27. What was your (HEAD'S) occupation when you started working for that employer during 1987? What sort of work did you do?

V15344

OCC

*C28. What were your most important activities or duties?

*C29. What was your starting salary or wage at that time?

\$ _____ PER _____

V15345

RATE

*C30. And how many hours a week did you work when you started?

V15346 HOURS PER WEEK

*C31. In which months during 1987 were you working for that employer as your main job?

ALL OR JAN FEB MAR APR MAY JUNE JULY AUG SEPT OCT NOV DEC

V15347-V15358

*C32. Did you have any (other) main-job employers at any time during 1987? Again, if you were self-employed on a main job, count yourself as an employer.

1. YES 5. NO → TURN TO P. 24, C52

*C33. In what month and year did you start working for that (other) main-job employer?

V15360

YEAR: V15361 97. BEFORE 1987, DK EXACT YEAR 98. DK YEAR AT ALL

MONTH DAY [IF VOLUNTEERED]

*C34. In which months during 1987 were you working for that employer?

ALL OR JAN FEB MAR APR MAY JUNE JULY AUG SEPT OCT NOV DEC

V15362-V15373

*C35. On this main job, were you (HEAD) self-employed, were you employed by someone else, or what?
V15374

3. SELF-EMPLOYED ONLY	2. BOTH SOMEONE ELSE AND SELF	1. SOMEONE ELSE ONLY
-----------------------	-------------------------------	----------------------

*C36. Was that an unincorporated business or a corporation?
V15375

1. UNINCORPORATED
2. CORPORATION

*C37. Did you (HEAD) work for the federal, state, or local government, a private company, or what?
V15376

1. FEDERAL GOV'T	2. STATE GOV'T	3. LOCAL GOV'T
4. PRIVATE NON-GOV'T	9. DON'T KNOW	
7. OTHER (SPECIFY): _____		

*C38. What was your occupation when you first started working for them? What sort of work did you do?

V15377

•			
---	--	--	--

OCC

*C39. What were your most important activities or duties?

*C40. What kind of business or industry was that in?

V15378

•			
---	--	--	--

IND

*C41. What was your starting wage or salary with that employer?
\$ _____ PER _____

V15379

•			
---	--	--	--

RATE

*C42. And how many hours a week did you work when you first started?
V15380 _____ HOURS PER WEEK

*C43. During 1987, did your job title or position with that employer change?
V15381

1. YES	5. NO → GO TO C46
--------	-------------------

*C44. In what month did that happen?
V15382 _____ MONTH

*C45. Was that a promotion with higher pay, a major change in your duties but with the same pay, or what?
V15383 _____

*C46. Have you stopped working for that employer?
V15384

1. YES	5. NO → GO TO C51
--------	-------------------

*C47. In what month and year did you stop working for that employer?
V15385 _____ MONTH DAY [IF VOLUNTEERED]

V15386

1987	1988	98. 1987 or 1988, DK WHICH
------	------	----------------------------

*C48. What happened with that employer--did the company go out of business, were you (HEAD) laid off, did you quit, or what?
V15387 _____

*C49. What was your (HEAD'S) final wage or salary when you left that employer?
\$ _____ PER _____

V15388

•			
---	--	--	--

RATE

*C50. And how many hours a week did you work just before you left?
V15389 _____ HOURS PER WEEK

*C51. Did you have any other main-job employers at any time during 1987? (Remember to count yourself as an employer if you were self-employed then on a main job.)
V15390

1. YES	5. NO → NEXT PAGE, C52
--------	------------------------

TURN TO PINK WORK HISTORY SUPPLEMENT

NUMBER OF ADDITIONAL WORK HISTORY SUPPLEMENTS=V15391

CONVERSION TABLE: WEEK EQUIVALENTS

DAYS TO WEEKS (BASED ON 5-DAY WORK WEEK)		MONTHS TO WEEKS	
1 DAY = .2 WEEKS	1 MONTH = 4.3 WEEKS	2 MONTHS = 8.6 WEEKS	
2 DAYS = .4 WEEKS	3 MONTHS = 13.0 WEEKS	4 MONTHS = 17.3 WEEKS	
3 DAYS = .6 WEEKS	5 MONTHS = 21.6 WEEKS	6 MONTHS = 26.0 WEEKS	
4 DAYS = .8 WEEKS	7 MONTHS = 30.3 WEEKS	8 MONTHS = 34.6 WEEKS	
5 DAYS = 1.0 WEEKS	9 MONTHS = 39.0 WEEKS	10 MONTHS = 43.3 WEEKS	
	11 MONTHS = 47.6 WEEKS	12 MONTHS = 52.0 WEEKS	

*C52. We're interested in how you (HEAD) spent your time from January through December 1987, regardless of whether or not you were employed. I know you may have given me some of this information already, but my instructions are to ask these questions of everybody. Did you take any vacation or time off during 1987?

1. YES 5. NO → GO TO C55

*C53. How much vacation or time off did you take?
 _____ DAYS V15393 WEEKS MONTHS

C54. When was that? [GET DAY IF VOLUNTEERED]
 FROM _____ THRU _____ FROM _____ THRU _____

*C55. Did you miss any work in 1987 because someone else was sick?
 V15394

1. YES 5. NO → GO TO C58

*C56. How much work did you miss?
 _____ DAYS V15395 WEEKS MONTHS

C57. When was that? TOTAL ANNUAL HOURS=Edited V14836

*C58. Did you miss any work in 1987 because you were sick?
 V15396

1. YES 5. NO → NEXT PAGE, C61

*C59. How much work did you miss?
 _____ DAYS V15397 WEEKS MONTHS

C60. When was that? TOTAL ANNUAL HOURS=Edited V14838

FOR IWER
 CALCULATIONS
 ONLY

+ _____

+ _____

*C61. Did you miss any work in 1987 because you were on strike?
 V15398

1. YES 5. NO → GO TO C64

*C62. How much work did you miss?
 _____ DAYS V15399 WEEKS MONTHS

C63. When was that? [GET DAY IF VOLUNTEERED]
 FROM _____ THRU _____ FROM _____ THRU _____
 TOTAL ANNUAL HOURS=Edited V14840

*C64. Did you miss any work in 1987 because you were unemployed and looking for work or temporarily laid off?
 V15400

1. YES 5. NO → GO TO C67

*C65. How much work did you miss?
 _____ DAYS V15401 WEEKS MONTHS

C66. When was that? [GET DAY IF VOLUNTEERED]
 FROM _____ THRU _____ FROM _____ THRU _____
 TOTAL ANNUAL HOURS=Edited V14842

*C67. Were there any weeks in 1987 when you didn't have a job and were not looking for one?
 V15402

1. YES 5. NO → GO TO C70

*C68. How much time was that?
 _____ DAYS V15403 WEEKS MONTHS

C69. When was that? [GET DAY IF VOLUNTEERED]
 FROM _____ THRU _____ FROM _____ THRU _____
 TOTAL ANNUAL HOURS=Edited V14844

*C70. Then, how many weeks did you actually work on your main job(s) in 1987?
 V15404

1. YES 5. NO → GO TO C70

ALL THE REST ANNUAL WORK HOURS ON MAIN JOB=Edited V14829

IF TOTAL DOES NOT EQUAL 52 WEEKS OR 12 MONTHS, RECONCILE WITH R OR EXPLAIN BELOW:
 TOTAL ANNUAL WORK HOURS=Edited V14835

*C71. And, on the average, how many hours a week did you work on your main job(s) in 1987?
 V15405

*C72. Did you work any overtime which isn't included in that?
 V15406

1. YES 5. NO → NEXT PAGE, C74

C73. How many hours did that overtime amount to in 1987?
 V14831 (Edited) TOTAL OVERTIME HOURS IN 1987

TOTAL

TOTAL NUMBER OF EXTRA JOBS=V15408

*C74. (Besides the weeks and hours you have just told me about,) did you (HEAD) have an extra job or other way of making money in addition to your main job(s) in 1987?

1. YES 5. NO -> TURN TO P. 28, SECTION D

*C75. Did you (HEAD) work for the federal, state, or local government, a private company, or what?

1. FEDERAL GOV'T 2. STATE GOV'T 3. LOCAL GOV'T 4. PRIVATE NON-GOV'T 9. DON'T KNOW 7. OTHER (SPECIFY):

*C76. What was your occupation? What sort of work did you do? V15410 OCC

C77. What were your most important activities or duties?

*C78. What kind of business or industry was that in? V15411 IND

*C79. About how much did you make at this? V15412 RATE

*C80. And, how many weeks did you work on this job in 1987? V15413 WEEKS IN 1987

*C81. On the average, how many hours a week did you work on this job? V15414 HOURS PER WEEK IN 1987

*C82. In what month and year did you start working for that employer? V15415 MONTH V15416 YEAR

*C83. In which months during 1987 were you working for that employer? V15417- V15428 ALL OR JAN FEB MAR APR MAY JUNE JULY AUG SEPT OCT NOV DEC

*C84. Have you stopped working for that employer? V15429 1. YES 5. NO -> NEXT PAGE, C86

*C85. In what month and year was that? V15430 MONTH DAY [IF VOLUNTEERED] 1987 1988 98. 1987 or 1988, DK WHICH

C86. Did you have any other extra jobs in 1987?

YES NO -> NEXT PAGE, SECTION D

*C87. Did you (HEAD) work for the federal, state, or local government, a private company, or what? V15432

1. FEDERAL GOV'T 2. STATE GOV'T 3. LOCAL GOV'T 4. PRIVATE NON-GOV'T 9. DON'T KNOW 7. OTHER (SPECIFY):

*C88. What was your occupation? What sort of work did you do? V15433 OCC

C89. What were your most important activities or duties?

*C90. What kind of business or industry was that in? V15434 IND

*C91. About how much did you make at this? V15435 RATE

*C92. And, how many weeks did you work on this job in 1987? V15436 WEEKS IN 1987

*C93. On the average, how many hours a week did you work on this job? V15437 ANNUAL WORK HOURS ON EXTRA JOB=Edited V14833 HOURS PER WEEK IN 1987

*C94. In what month and year did you start working for that employer? V15438 MONTH V15439 YEAR

*C95. In which months during 1987 were you working for that employer? V15440- V15451 ALL OR JAN FEB MAR APR MAY JUNE JULY AUG SEPT OCT NOV DEC

*C96. Have you stopped working for that employer? V15452 1. YES 5. NO -> GO TO C98

*C97. In what month and year was that? V15453 MONTH DAY [IF VOLUNTEERED] 1987 1988 98. 1987 or 1988, DK WHICH

C98. Did you have any other extra jobs in 1987? YES NO -> NEXT PAGE, SECTION D ASK C87-C98 AGAIN

SECTION D: EMPLOYMENT OF WIFE/"WIFE"

*D1. INTERVIEWER CHECKPOINT

SEE FU LISTING, (P. 2 OF COVER SHEET)
V15455

HEAD IS MALE

3. HEAD IS FEMALE → TURN TO P. 52, SECTION F

1. WIFE/"WIFE" IN FU NOW

2. NO WIFE/"WIFE" IN FU NOW → TURN TO P. 52, SECTION F

*D1a. We would like to know about what your (wife/"WIFE") does--is she working now, looking for work, retired, keeping house, a student, or what?

[IF R MENTIONS CODES 1-3, CHECK ONE AND ONLY ONE BOX, AND NONE FROM 4-8]

1. WORKING NOW

2. ONLY TEMPORARILY LAID OFF, SICK LEAVE OR MATERNITY LEAVE

3. LOOKING FOR WORK, UNEMPLOYED

NEXT PAGE, D4

[IF R MENTIONS ONLY CODES 4-8, CHECK AS MANY AS APPLY]

4. RETIRED → *D2. In what year did your (wife/"WIFE") retire?
V15457

5. PERMANENTLY DISABLED →

6. KEEPING HOUSE →

7. STUDENT →

8. OTHER (SPECIFY): _____ →

V15458

*D3. Is she doing any work for money now at all?
1. YES 5. NO

NEXT PAGE, TURN TO P. 41, SECTION E

*D4. On her main job, is your (wife/"WIFE") self-employed, is she employed by someone else, or what?

3. SELF-EMPLOYED ONLY

2. BOTH SOMEONE ELSE AND SELF

1. SOMEONE ELSE ONLY

V15460 *D5. Is that an unincorporated business or a corporation?
1. UNINCORPORATED
2. CORPORATION

V15461 *D6. Does your (wife/"WIFE") work for the federal, state, or local government, a private company, or what?
1. FEDERAL GOV'T 2. STATE GOV'T 3. LOCAL GOV'T
4. PRIVATE NON-GOV'T 9. DON'T KNOW
7. OTHER (SPECIFY): _____

V15462 *D7. Is her current job covered by a union contract?
1. YES 5. NO → GO TO D9

V15463 *D8. Does she belong to that labor union?
1. YES 5. NO

*D9. What is your (wife's/"WIFE's") main occupation? What sort of work does she do?

_____ V15464 OCC

_____ V15465 IND

D10. What are her most important activities or duties?

D11. What kind of business or industry is that in?

*D12. (On her main job,) is your (wife/"WIFE") salaried, paid by the hour, or what?
15466

1. SALARIED

3. PAID BY HOUR

7. OTHER

*D13. How much is her salary?
\$ _____ PER WEEK
OR
\$ _____ PER MONTH
OR
\$ _____ PER YEAR
V15467
*REG [] [] [] [] []

*D14. If she were to work more hours than usual during some week, would she get paid for those extra hours of work?
1. YES 5. NO
NEXT PAGE, D20

*D15. About how much would she make per hour for those extra hours?
\$ _____ PER HOUR
TIME AND A HALF
DOUBLE TIME
*OT [] [] [] [] [] V15469
NEXT PAGE, D20

*D16. What is her hourly wage rate for her regular work time?
\$ _____ PER HOUR
*REG [] [] [] [] [] V15470
*D17. What is her hourly wage rate for overtime?
\$ _____ PER HOUR
TIME AND A HALF

DOUBLE TIME
OTHER (SPECIFY):

*OT [] [] [] [] [] V15471
NEXT PAGE, D20

*D18. How is that?
V15472

*D19. If she worked an extra hour, how much would she earn for that hour?
\$ _____ PER HOUR
*OT [] [] [] [] [] V15473
NEXT PAGE, D20

*D20. Has your (wife/"WIFE") been looking for another job during the past four weeks?
V15474

1. YES

5. NO → GO TO D22

*D21. What has she been doing the last four weeks to find another job? [CHECK ALL THAT APPLY]

V15476 A. CHECKED WITH PUBLIC EMPLOYMENT AGENCY NOTHING V15475
V15477 B. CHECKED WITH PRIVATE EMPLOYMENT AGENCY
V15478 C. CHECKED WITH CURRENT EMPLOYER DIRECTLY
V15479 D. CHECKED WITH OTHER EMPLOYER DIRECTLY
V15480 E. CHECKED WITH FRIENDS OR RELATIVES
V15481 F. PLACED OR ANSWERED ADS
V15482 G. OTHER (SPECIFY): _____

D22. INTERVIEWER CHECKPOINT

SEE D4, (P. 29)--WHETHER SELF-EMPLOYED
 A. WIFE/"WIFE" WORKS FOR SOMEONE ELSE ONLY B. ALL OTHERS → NEXT PAGE, D24

*D23. How many years' experience does she have altogether with her present employer?

_____ MONTHS *OR* _____ YEARS
* V15483
[] [] [] [] []
MOS

*D24. In what month and year did your (wife/"WIFE") start working for her present employer? (Count her as the employer if she is self-employed, and) give us her most recent start date if she has gone to work for them more than once. [IF NECESSARY: What would be your best guess? Did she start before 1987?]

V15484 MONTH DAY [IF VOLUNTEERED]

V15485 1987 1988 96. 1987 OR 1988, DK WHICH OTHER YEAR: 97. BEFORE 1987, DK EXACT YEAR 98. DK YEAR AT ALL

V15486 *D25. Is that when she started working in her present (position/work situation)?
 1. YES 5. NO
 NEXT PAGE, D37

V15492 MONTH DAY [IF VOLUNTEERED]
 V15493 1987 1988
 NEXT PAGE, D35

V15494 MONTH DAY [IF VOLUNTEERED]
 1987 1988 OTHER YEAR:
 GO TO D34 V15495
 NEXT PAGE, D39

V15488 *D26. In what month and year did she start working in her present (position/work situation)?
 V15487 MONTH DAY [IF VOLUNTEERED]
 1987 → GO TO D29 1988

V15489 *D27. Did she change (positions/work situations) with this employer at any time during 1987?
 1. YES 5. NO → NEXT PAGE, D35

*D28. In what month did that happen?
 V15490 MONTH

*D29. Was that a promotion with higher pay, a major change in her duties but with the same pay, or what?
 V15491
 NEXT PAGE, D35

*D30. In what month and year did she start working in her present (position/work situation)?
 V15492 MONTH DAY [IF VOLUNTEERED]
 V15493 1987 1988
 NEXT PAGE, D35

*D31. In what month and year did she start working in her present (position/work situation)?
 V15494 MONTH DAY [IF VOLUNTEERED]
 1987 1988 OTHER YEAR:
 GO TO D34 V15495
 NEXT PAGE, D39

V15496 *D32. Did she change (positions/work situations) with this employer at any time during 1987?
 1. YES 5. NO → NEXT PAGE, D39

*D33. In what month did that happen?
 V15497 MONTH

*D34. Was that a promotion with higher pay, a major change in her duties but with the same pay, or what?
 V15498
 NEXT PAGE, D39

*D35. What was your (wife's/"WIFE'S") occupation when she started working for that employer during 1987? What sort of work did she do?

V15499
 OCC

D36. What were her most important activities or duties?

*D37. What was her starting salary or wage at that time?

V15500
 \$ _____ PER _____
 RATE

*D38. And how many hours a week did she work when she started?

V15501 _____ HOURS PER WEEK

*D39. In which months during 1987 was she working for that employer as her main job?

ALL OR JAN FEB MAR APR MAY JUNE JULY AUG SEPT OCT NOV DEC

V15502-V15513

*D40. Did she have any (other) main-job employers at any time during 1987? Again, if she was self-employed on a main job, count her as an employer.

V15514 1. YES 5. NO → TURN TO P. 36, D60

*D41. In what month and year did she start working for that (other) main-job employer?

V15515 YEAR: V15516 97. BEFORE 1987, DK EXACT YEAR 98. DK YEAR AT ALL
 MONTH DAY [IF VOLUNTEERED]

*D42. In which months during 1987 was she working for that employer?

ALL OR JAN FEB MAR APR MAY JUNE JULY AUG SEPT OCT NOV DEC

V15517-V15528

*D43. On this main job, was she self-employed, was she employed by someone else, or what?

V15529

- 3. SELF-EMPLOYED ONLY
- 2. BOTH SOMEONE ELSE AND SELF
- 1. SOMEONE ELSE ONLY

V15530

- *D44. Was that an unincorporated business or a corporation?
- 1. UNINCORPORATED
 - 2. CORPORATION

V15531

- *D45. Did she work for the federal, state, or local government, a private company, or what?
- 1. FEDERAL GOV'T
 - 2. STATE GOV'T
 - 3. LOCAL GOV'T
 - 4. PRIVATE NON-GOV'T
 - 9. DON'T KNOW
 - 7. OTHER (SPECIFY): _____

*D46. What was her occupation when she first started working for them? What sort of work did she do?

V15532

• [] [] []

OCC

*D47. What were her most important activities or duties?

*D48. What kind of business or industry was that in?

V15533

• [] [] []

IND

*D49. What was her starting wage or salary with that employer?

\$ _____ PER _____

V15534

• [] [] [] []

RATE

*D50. And how many hours a week did she work when she first started?

_____ HOURS PER WEEK

*D51. During 1987, did her job title or position with that employer change?

V15536

- 1. YES
- 5. NO → GO TO D54

*D52. In what month did that happen?

V15537

MONTH

*D53. Was that a promotion with higher pay, a major change in her duties but with the same pay, or what?

V15538

*D54. Has she stopped working for that employer?

V15539

- 1. YES
- 5. NO → GO TO D59

*D55. In what month and year did she stop working for that employer?

V15540

MONTH DAY [IF VOLUNTEERED]

1987 1988 98. 1987 or 1988, DK WHICH

V15541

*D56. What happened with that employer--did the company go out of business, was she laid off, did she quit, or what?

V15542

*D57. What was your (wife's/"WIFE'S") final wage or salary when she left that employer?

\$ _____ PER _____

V15543

• [] [] [] []

RATE

*D58. And how many hours a week did she work just before she left?

V15544 HOURS PER WEEK

*D59. Did she have any other main-job employers at any time during 1987? (Remember to count her as an employer if she was self-employed then on a main job.)

V15545

- 1. YES
- 5. NO → NEXT PAGE, D60

TURN TO PINK WORK HISTORY SUPPLEMENT

NUMBER OF ADDITIONAL WORK HISTORY SUPPLEMENTS=V15546

25

DAYS TO WEEKS (BASED ON 5-DAY WORK WEEK)		MONTHS TO WEEKS	
1 DAY = .2 WEEKS	1 MONTH = 4.3 WEEKS	2 MONTHS = 8.6 WEEKS	
2 DAYS = .4 WEEKS	3 MONTHS = 13.0 WEEKS	4 MONTHS = 17.3 WEEKS	
3 DAYS = .6 WEEKS	5 MONTHS = 21.6 WEEKS	6 MONTHS = 26.0 WEEKS	
4 DAYS = .8 WEEKS	7 MONTHS = 30.3 WEEKS	8 MONTHS = 34.6 WEEKS	
5 DAYS = 1.0 WEEKS	9 MONTHS = 39.0 WEEKS	10 MONTHS = 43.3 WEEKS	
	11 MONTHS = 47.6 WEEKS	12 MONTHS = 52.0 WEEKS	

*D60. We're interested in how your (wife/"WIFE") spent her time from January through December 1987. I know you may have given me some of this information already, but my instructions are to ask these questions of everybody. Did she miss any work in 1987 because you or someone else was sick?

1. YES 5. NO → GO TO D63

*D61. How much work did she miss?

_____ DAYS V15548 WEEKS _____ MONTHS

D62. When was that? TOTAL ANNUAL HOURS=Edited V14866

*D63. Did she miss any work in 1987 because she was sick?

1. YES 5. NO → GO TO D66

*D64. How much work did she miss?

_____ DAYS V15550 WEEKS _____ MONTHS

D65. When was that? TOTAL ANNUAL HOURS=Edited V14868

*D66. Did she take any vacation or time off during 1987?

1. YES 5. NO → NEXT PAGE, D69

*D67. How much vacation or time off did she take?

_____ DAYS V15552 WEEKS _____ MONTHS

D68. When was that? [GET DAY IF VOLUNTEERED]

FROM _____ THRU _____ FROM _____ THRU _____

FOR IWER
CALCULATIONS
ONLY

*D69. Did she miss any work in 1987 because she was on strike?

1. YES 5. NO → GO TO D72

*D70. How much work did she miss?

_____ DAYS V15554 WEEKS _____ MONTHS

D71. When was that? [GET DAY IF VOLUNTEERED]

FROM _____ THRU _____ FROM _____ THRU _____

TOTAL ANNUAL HOURS=Edited V14870

*D72. Did she miss any work in 1987 because she was unemployed and looking for work or temporarily laid off?

1. YES 5. NO → GO TO D75

*D73. How much work did she miss?

_____ DAYS V15556 WEEKS _____ MONTHS

D74. When was that? [GET DAY IF VOLUNTEERED]

FROM _____ THRU _____ FROM _____ THRU _____

TOTAL ANNUAL HOURS=Edited V14872

*D75. Were there any weeks in 1987 when she didn't have a job and was not looking for one?

1. YES 5. NO → GO TO D78

*D76. How much time was that?

_____ DAYS V15558 WEEKS _____ MONTHS

D77. When was that? [GET DAY IF VOLUNTEERED]

FROM _____ THRU _____ FROM _____ THRU _____

TOTAL ANNUAL HOURS=Edited V14874

*D78. Then, how many weeks did she actually work on her main job(s) in 1987?

V15559
WEEKS IN 1987

00. DID NOT WORK
AT ALL IN 1987
NEXT PAGE, D82

ALL THE REST ANNUAL WORK HOURS ON MAIN JOB=Edited V14859

TOTAL

IF TOTAL DOES NOT EQUAL 52 WEEKS OR 12 MONTHS, RECONCILE WITH R OR EXPLAIN BELOW:
TOTAL ANNUAL WORK HOURS=Edited V14865

*D79. And, on the average, how many hours a week did she work on her main job(s) in 1987?

V15560 _____ HOURS PER WEEK IN 1987

*D80. Did she work any overtime which isn't included in that?

1. YES 5. NO → NEXT PAGE, D82

D81. How many hours did that overtime amount to in 1987?

V14861 (Edited) TOTAL OVERTIME HOURS IN 1987

TOTAL NUMBER OF EXTRA JOBS=V15563

*D82. Did your (wife/"WIFE") have an extra job or other way of making money in addition to her main job(s) in 1987?
V15562

1. YES 5. NO →TURN TO P. 52, SECTION F

*D83. Did your (wife/"WIFE") work for the federal, state, or local government, a private company, or what?
V15564

1. FEDERAL GOV'T 2. STATE GOV'T 3. LOCAL GOV'T 4. PRIVATE NON-GOV'T 9. DON'T KNOW 7. OTHER (SPECIFY):

*D84. What was her occupation? What sort of work did she do?
_____ V15565
• [] [] []
OCC

D85. What were her most important activities or duties?

*D86. What kind of business or industry was that in?
_____ V15566
• [] [] []
IND

*D87. About how much did she make at this?
\$ _____ PER _____
V15567
• [] [] [] []
RATE

*D88. And, how many weeks did she work on this job in 1987?
_____ V15568
WEEKS IN 1987

*D89. On the average, how many hours a week did she work on this job?
_____ V15569
HOURS PER WEEK IN 1987
ANNUAL WORK HOURS ON EXTRA JOBS=Edited V14863

*D90. In what month and year did she start working for that employer?
V15570 V15571
MONTH YEAR

V15572-
V15583 *D91. In which months during 1987 was she working for that employer?
[ALL] [OR] [JAN] [FEB] [MAR] [APR] [MAY] [JUNE] [JULY] [AUG] [SEPT] [OCT] [NOV] [DEC]

*D92. Has she stopped working for that employer?
V15584 1. YES 5. NO →NEXT PAGE, D94

*D93. In what month and year was that?
V15585 V15586
MONTH DAY [IF VOLUNTEERED] 1987 1988 98. 1987 or 1988, DK WHICH

D94. Did she have any other extra jobs in 1987?
YES NO →TURN TO P. 52, SECTION F

*D95. Did she work for the federal, state, or local local government, a private company, or what?
V15587 1. FEDERAL GOV'T 2. STATE GOV'T 3. LOCAL GOV'T 4. PRIVATE NON-GOV'T 9. DON'T KNOW 7. OTHER (SPECIFY):

*D96. What was her occupation? What sort of work did she do?
_____ V15588
• [] [] []
OCC

D97. What were her most important activities or duties?

*D98. What kind of business or industry was that in?
_____ V15589
• [] [] []
IND

*D99. About how much did she make at this?
\$ _____ PER _____
V15590
• [] [] [] []
RATE

*D100. And, how many weeks did she work on this job in 1987?
_____ V15591
WEEKS IN 1987

*D101. On the average, how many hours a week did she work on this job?
_____ V15592
HOURS PER WEEK IN 1987

*D102. In what month and year did she start working for that employer?
V15593 V15594
MONTH YEAR

V15595-
V15606 *D103. ANNUAL WORK HOURS ON EXTRA JOBS=Edited V14863
In which months during 1987 was she working for that employer?
[ALL] [OR] [JAN] [FEB] [MAR] [APR] [MAY] [JUNE] [JULY] [AUG] [SEPT] [OCT] [NOV] [DEC]

*D104. Has she stopped working for that employer?
V15607 1. YES 5. NO →GO TO D106

*D105. In what month and year was that?
V15608 V15609
MONTH DAY [IF VOLUNTEERED] 1987 1988 98. 1987 or 1988, DK WHICH

D106. Did she have any other extra jobs in 1987?
YES NO →TURN TO P. 52, SECTION F
ASK D95-D106 AGAIN

SECTION E: WIFE/"WIFE" IS NOT WORKING NOW ["NO" TO D3, (P. 28)]

*E1. Has your (wife/"WIFE") been looking for work during the past four weeks?
V15610

1. YES

5. NO

→NEXT PAGE, E4



*E2. What has she been doing the last four weeks to find work?
[CHECK ALL THAT APPLY]

A. CHECKED WITH PUBLIC EMPLOYMENT AGENCY

V15612

NOTHING

V15611

B. CHECKED WITH PRIVATE EMPLOYMENT AGENCY

V15613

C. CHECKED WITH PREVIOUS EMPLOYER DIRECTLY

V15614

D. CHECKED WITH OTHER EMPLOYER DIRECTLY

V15615

E. CHECKED WITH FRIENDS OR RELATIVES

V15616

F. PLACED OR ANSWERED ADS

V15617

G. OTHER (SPECIFY): _____

V15618

*E3. How long has she been looking for work?

V15619

•
WKS

THIS IS A BLANK PAGE!

*E4. Has your (wife/"WIFE") ever done any work for money?
V15620

1. YES 5. NO → GO TO E6

*E5. In what month and year did she last work? [IF NECESSARY: What would be your best guess? Did she last work before 1987?]

V15621

MONTH DAY [IF VOLUNTEERED]

V15622 1987 1988 96. 1987 OR 1988, DK WHICH OTHER YEAR: 97. BEFORE 1987, DK EXACT YEAR 98. DK YEAR AT ALL

V15623

*E6. Were there any times in 1987 when she was looking for work?
1. YES 5. NO → TURN TO P. 52, SECTION F

*E7. How many weeks was that? V15624 OR 52. ALL

E8. When was that? FROM THRU TURN TO P. 52, SECTION F

*E9. What was her occupation on her last job? What sort of work did she do?

V15625 V15626

• [] [] [] [] • [] [] [] []

OCC IND

E10. What were her most important activities or duties?

E11. What kind of business or industry was that in?

*E12. On this main job, was your (wife/"WIFE") self-employed, was she employed by someone else, or what?
V15627

3. SELF-EMPLOYED ONLY 2. BOTH SOMEONE ELSE AND SELF 1. SOMEONE ELSE ONLY

V15628

*E13. Was that an unincorporated business or a corporation?
1. UNINCORPORATED
2. CORPORATION

V15629

*E14. Did she work for the federal, state, or local government, a private company, or what?
1. FEDERAL GOV'T 2. STATE GOV'T 3. LOCAL GOV'T
4. PRIVATE NON-GOV'T 9. DON'T KNOW
7. OTHER (SPECIFY): _____

*E15. What happened with that employer--did the company go out of business, was your (wife/"WIFE") laid off, did she quit, or what?

V15630

*E16. In what month and year did your (wife/"WIFE") start working for her last employer? (Count her as the employer if she was self-employed, and) give us her most recent start date if she went to work for them more than once. [IF NECESSARY: What would be your best guess? Did she start before 1987?]

V15632

V15631
MONTH DAY [IF VOLUNTEERED]

1987 1988 96. 1987 OR 1988, DK WHICH OTHER YEAR: 97. BEFORE 1987, DK EXACT YEAR 98. DK YEAR AT ALL

V15633 *E17. Is that when she started working in her last (position/work situation)?
1. YES 5. NO
NEXT PAGE, E29

V15639 *E22. In what month and year did she start working in her last (position/work situation)?
MONTH DAY [IF VOLUNTEERED]
V15640 1987 1988
NEXT PAGE, E32

V15641 *E23. In what month and year did she start working in her last (position/work situation)?
MONTH DAY [IF VOLUNTEERED]
1987 1988 OTHER YEAR:
GO TO E26 V15642
NEXT PAGE, E31

V15634 *E18. In what month and year did she start working in her last (position/work situation)?
MONTH DAY [IF VOLUNTEERED]
V15635 1987 → GO TO E21 1988

V15636 *E19. Did she change (positions/work situations) with this employer at any time during 1987?
1. YES 5. NO → NEXT PAGE, E27

*E20. In what month did that happen?
V15637 MONTH

*E21. Was that a promotion with higher pay, a major change in her duties but with the same pay, or what?
V15638
NEXT PAGE, E27

*E24. Did she change (positions/work situations) with this employer at any time during 1987?
V15643 1. YES 5. NO → NEXT PAGE, E31

*E25. In what month did that happen?
V15644 MONTH

*E26. Was that a promotion with higher pay, a major change in her duties but with the same pay, or what?
V15645
NEXT PAGE, E31

*E27. What was your (wife's/"WIFE'S") occupation when she started working for that employer during 1987? What sort of work did she do?

V15646
OCC

*E28. What were her most important activities or duties?

*E29. What was her starting salary or wage at that time?

V15647
\$ _____ PER _____
RATE

*E30. And how many hours a week did she work when she started?

V15648 _____ HOURS PER WEEK

*E31. In which months during 1987 was she working for that employer as her main job?

ALL OR JAN FEB MAR APR MAY JUNE JULY AUG SEPT OCT NOV DEC
V15649-V15660

*E32. Did she have any (other) main-job employers at any time during 1987? Again, if she was self-employed on a main job, count her as an employer.

1. YES 5. NO → TURN TO P. 48, E52

*E33. In what month and year did she start working for that (other) main-job employer?

V15662 YEAR: V15663 97. BEFORE 1987, DK EXACT YEAR 98. DK YEAR AT ALL
MONTH DAY [IF VOLUNTEERED]

*E34. In which months during 1987 was she working for that employer?

ALL OR JAN FEB MAR APR MAY JUNE JULY AUG SEPT OCT NOV DEC
V15664-V15675

*E35. On this main job, was she self-employed, was she employed by someone else, or what?

V15676

3. SELF-EMPLOYED ONLY	2. BOTH SOMEONE ELSE AND SELF	1. SOMEONE ELSE ONLY
-----------------------	-------------------------------	----------------------

V15677

*E36. Was that an unincorporated business or a corporation? 1. UNINCORPORATED 2. CORPORATION	*E37. Did she work for the federal, state, or local government, a private company, or what? V15678 1. FEDERAL GOV'T 2. STATE GOV'T 3. LOCAL GOV'T 4. PRIVATE NON-GOV'T 9. DON'T KNOW 7. OTHER (SPECIFY): _____
--	---

*E38. What was her occupation when she first started working for them? What sort of work did she do?

V15679

•			
---	--	--	--

OCC

E39. What were her most important activities or duties?

*E40. What kind of business or industry was that in?

V15680

•			
---	--	--	--

IND

*E41. What was her starting wage or salary with that employer?

\$ _____ PER _____

V15681

•			
---	--	--	--

RATE

*E42. And how many hours a week did she work when she first started?

V15682 _____ HOURS PER WEEK

*E43. During 1987, did her job title or position with that employer change?

V15683

1. YES	5. NO → GO TO E46
--------	-------------------

*E44. In what month did that happen?

V15684 _____

MONTH

*E45. Was that a promotion with higher pay, a major change in her duties but with the same pay, or what?

V15685 _____

*E46. Has she stopped working for that employer?

V15686

1. YES	5. NO → GO TO E51
--------	-------------------

*E47. In what month and year did she stop working for that employer?

V15687 _____

MONTH DAY [IF VOLUNTEERED]

V15688

1987	1988	98. 1987 or 1988, DK WHICH
------	------	----------------------------

*E48. What happened with that employer--did the company go out of business, was she laid off, did she quit, or what?

V15689 _____

*E49. What was your (wife's/"WIFE'S") final wage or salary when she left that employer?

\$ _____ PER _____

V15690

•			
---	--	--	--

RATE

*E50. And how many hours a week did she work just before she left?

V15691 _____ HOURS PER WEEK

*E51. Did she have any other main job employers at any time during 1987? (Remember to count her as an employer if she was self-employed then on a main job.)

V15692

1. YES	5. NO → NEXT PAGE, E52
--------	------------------------

TURN TO PINK WORK HISTORY SUPPLEMENT

NUMBER OF ADDITIONAL WORK HISTORY SPELLS=V15693

CONVERSION TABLE: WEEK EQUIVALENTS

DAYS TO WEEKS (BASED ON 5-DAY WORK WEEK)		MONTHS TO WEEKS	
1 DAY = .2 WEEKS	1 MONTH = 4.3 WEEKS	2 MONTHS = 8.6 WEEKS	
2 DAYS = .4 WEEKS	3 MONTHS = 13.0 WEEKS	4 MONTHS = 17.3 WEEKS	
3 DAYS = .6 WEEKS	5 MONTHS = 21.6 WEEKS	6 MONTHS = 26.0 WEEKS	
4 DAYS = .8 WEEKS	7 MONTHS = 30.3 WEEKS	8 MONTHS = 34.6 WEEKS	
5 DAYS = 1.0 WEEKS	9 MONTHS = 39.0 WEEKS	10 MONTHS = 43.3 WEEKS	
	11 MONTHS = 47.6 WEEKS	12 MONTHS = 52.0 WEEKS	

V15694 *E52. We're interested in how your (wife/"WIFE") spent her time from January through December 1987, regardless of whether or not she was employed. I know you may have given me some of this information already, but my instructions are to ask these questions of everybody. Did she take any vacation or time off during 1987?

1. YES 5. NO → GO TO E55

*E53. How much vacation or time off did she take?
 _____ DAYS V15695 WEEKS _____ MONTHS

E54. When was that? [GET DAY IF VOLUNTEERED]
 FROM _____ THRU _____ FROM _____ THRU _____

V15696 *E55. Did she miss any work in 1987 because you or someone else was sick?

1. YES 5. NO → GO TO E58

*E56. How much work did she miss?
 _____ DAYS V15697 WEEKS _____ MONTHS

E57. When was that? TOTAL ANNUAL HOURS=Edited V14866

V15698 *E58. Did she miss any work in 1987 because she was sick?

1. YES 5. NO → NEXT PAGE, E61

*E59. How much work did she miss?
 _____ DAYS V15699 WEEKS _____ MONTHS

E60. When was that? TOTAL ANNUAL HOURS=V14868

FOR IWER CALCULATIONS ONLY

*E61. Did she miss any work in 1987 because she was on strike?
 V15700

1. YES 5. NO → GO TO E64

*E62. How much work did she miss?
 _____ DAYS V15701 WEEKS _____ MONTHS

E63. When was that? [GET DAY IF VOLUNTEERED]
 FROM _____ THRU _____ FROM _____ THRU _____

TOTAL ANNUAL HOURS=Edited V14870
 *E64. Did she miss any work in 1987 because she was unemployed and looking for work or temporarily laid off?
 V15702

1. YES 5. NO → GO TO E67

*E65. How much work did she miss?
 _____ DAYS V15703 WEEKS _____ MONTHS

E66. When was that? [GET DAY IF VOLUNTEERED]
 FROM _____ THRU _____ FROM _____ THRU _____

TOTAL ANNUAL HOURS=Edited V14872
 *E67. Were there any weeks in 1987 when she didn't have a job and was not looking for one?
 V15704

1. YES 5. NO → GO TO E70

*E68. How much time was that?
 _____ DAYS V15705 WEEKS _____ MONTHS

E69. When was that? [GET DAY IF VOLUNTEERED]
 FROM _____ THRU _____ FROM _____ THRU _____

TOTAL ANNUAL HOURS=Edited V14874
 *E70. Then, how many weeks did she actually work on her main job(s) in 1987?

V15706 _____ WEEKS IN 1987

00. DID NOT WORK AT ALL IN 1987
 NEXT PAGE, E74

ALL THE REST ANNUAL WORK HOURS ON MAIN JOB=Edited V14859

IF TOTAL DOES NOT EQUAL 52 WEEKS OR 12 MONTHS, RECONCILE WITH R OR EXPLAIN BELOW:
 TOTAL ANNUAL WORK HOURS=Edited V14865

*E71. And, on the average, how many hours a week did she work on her main job(s) in 1987?

V15707 _____ HOURS PER WEEK IN 1987

*E72. Did she work any overtime which isn't included in that?
 V15708

1. YES 5. NO → NEXT PAGE, E74

E73. How many hours did that overtime amount to in 1987?
 V14861 (Edited) _____ TOTAL OVERTIME HOURS IN 1987

TOTAL NUMBER OF EXTRA JOBS=V15710

*E74. (Besides the weeks and hours you have just told me about,) did your (wife/"WIFE") have an extra job or other way of making money in addition to her main job(s) in 1987?

1. YES 5. NO → TURN TO P. 52, SECTION F

*E75. Did she work for the federal, state, or local government, a private company, or what?

1. FEDERAL GOV'T 2. STATE GOV'T 3. LOCAL GOV'T 4. PRIVATE NON-GOV'T 9. DON'T KNOW 7. OTHER (SPECIFY):

*E76. What was her occupation? What sort of work did she do? V15712
 _____ •
OCC

*E77. What were her most important activities or duties?

*E78. What kind of business or industry was that in? V15713
 _____ •
IND

*E79. About how much did she make at this? V15714
 \$ _____ PER _____
 •
RATE

*E80. And, how many weeks did she work on this job in 1987? V15715

WEEKS IN 1987

*E81. On the average, how many hours a week did she work on this job? V15716

HOURS PER WEEK IN 1987

ANNUAL WORK HOURS ON EXTRA JOBS=Edited V14863
 *E82. In what month and year did she start working for that employer?
V15717 V15718
MONTH YEAR

V15719- *E83. In which months during 1987 was she working for that employer?
 V15730 ALL OR JAN FEB MAR APR MAY JUNE JULY AUG SEPT OCT NOV DEC

*E84. Has she stopped working for that employer?
 V15731 1. YES 5. NO → NEXT PAGE, E86

*E85. In what month and year was that? V15732 V15733

MONTH DAY [IF VOLUNTEERED] 1987 1988 98. 1987 or 1988, DK WHICH

E86. Did she have any other extra jobs in 1987?

YES NO → NEXT PAGE, SECTION F

V15734 *E87. Did she work for the federal, state, or local local government, a private company, or what?

1. FEDERAL GOV'T 2. STATE GOV'T 3. LOCAL GOV'T 4. PRIVATE NON-GOV'T 9. DON'T KNOW 7. OTHER (SPECIFY):

*E88. What was her occupation? What sort of work did she do? V15735
 _____ •
OCC

E89. What were her most important activities or duties?

*E90. What kind of business or industry was that in? V15736
 _____ •
IND

*E91. About how much did she make at this? V15737
 \$ _____ PER _____
 •
RATE

*E92. And, how many weeks did she work on this job in 1987? V15738

WEEKS IN 1987

*E93. On the average, how many hours a week did she work on this job? V15739

HOURS PER WEEK IN 1987

*E94. In what month and year did she start working for that employer?
V15740 V15741
MONTH YEAR

V15742- *E95. In which months during 1987 was she working for that employer?
 V15753 ALL OR JAN FEB MAR APR MAY JUNE JULY AUG SEPT OCT NOV DEC

*E96. Has she stopped working for that employer? V15754
 1. YES 5. NO → GO TO E98

*E97. In what month and year was that? V15755 V15756

MONTH DAY [IF VOLUNTEERED] 1987 1988 98. 1987 or 1988, DK WHICH

E98. Did she have any other extra jobs in 1987?
 YES NO → NEXT PAGE, SECTION F
 ASK E87-E98 AGAIN

SECTION F: HOUSEWORK, CHILD CARE AND FOOD STAMPS

V15757 *F1. INTERVIEWER CHECKPOINT

SEE FU LISTING, (P. 2 OF COVER SHEET)

HEAD IS MALE

3. HEAD IS FEMALE → GO TO F3

1. WIFE/"WIFE" IN FU NOW

2. NO WIFE/"WIFE" IN FU NOW → GO TO F3

*F2. About how much time does your (wife/"WIFE") spend on housework in an average week? I mean time spent cooking, cleaning, and doing other work around the house.

V15758 HOURS PER WEEK

*F3. About how much time do you (HEAD) spend on housework in an average week? (I mean time spent cooking, cleaning, and doing other work around the house.)

ANNUAL HOURS=Edited V14893

V15759 HOURS PER WEEK

F4. INTERVIEWER CHECKPOINT

SEE FU LISTING, (P.2 OF COVERSHEET)

TWO OR MORE PERSONS IN FU

ONLY ONE PERSON IN FU → NEXT PAGE, F6

*F5. How many days a week does the family sit down and eat the main meal of the day together?

V15760

F6. INTERVIEWER CHECKPOINT

SEE FU LISTING, (P. 2 OF COVERSHEET)

A. SOMEONE UNDER AGE 15 IN 1987 FU

B. ALL OTHERS → GO TO F8

*F7. How much did you (and your family living there) pay for child care in 1987?

\$ _____ IN 1987

V15741
CH CARE

F8. Did you (or anyone else in your family) use government food stamps at any time in 1987?

YES

NO → NEXT PAGE, SECTION G

F9. How many dollars' worth of stamps did you get in 1987? V14895 (Edited)

\$ _____ PER MONTH OR \$ _____ PER TWO WEEKS

F10. During which months was that? ALL OR V14898-V14909 (Edited)

NUMBER OF MONTHS=Edited V14897

NEXT PAGE, SECTION G

SECTION G: INCOME, WEALTH, PARENTS AND HELP

G1. We try to understand how people all over the country are getting along financially, so now I have some questions about earnings and income.

*G2. INTERVIEWER CHECKPOINT
V15762

SEE B9 AND B10, (P. 5)--PRESENT OCCUPATION

1. HEAD IS A FARMER OR RANCHER

5. ALL OTHERS → GO TO G6

V15763

TOT REC'TS

*G3. What were your total receipts from farming in 1987, including soil bank payments and commodity credit loans? \$ _____ A

G4. What were your total operating expenses, not counting living expenses? \$ _____ B

G5. That left you a net income from farming of? (A - B =) \$ _____ C

LABOR=Edited V14911 ASSET=Edited V14922
*G6. Did you (or anyone else in the family there) own a business at any time in 1987 or have a financial interest in any business enterprise?
V15764

1. YES 5. NO → NEXT PAGE, G12

V15765

IND

*G7. What kind of business was that? _____

V15766 *G8. Who in the family owned that? _____

V15767 *G9. Did (you/he/she/they) put in any work time for this business in 1987?

1. YES → THESE WORK HOURS MUST BE REPORTED! 5. NO

V15768 *G10. Was it a corporation or an unincorporated business, or did (you/he/she/they) have an interest in both kinds?

1. CORPORATION NEXT PAGE, G12 2. UNINCORPORATED 3. BOTH 4. DON'T KNOW

G11. How much was (your/his/her/their) share of the total income from the business in 1987--that is, the amount (you/he/she/they) took out plus any profit left in? [IF ZERO: Did you have a loss? How much was it?]

\$ _____ PROFIT OR \$- _____ LOSS

LABOR=V14912 (HEAD), V14920 (WIFE) (EDITED VARS.)
ASSET=V14923 (HEAD & WIFE) (EDITED VAR.)

G12. Did you (HEAD) earn wages or salaries in 1987 from working on any jobs? (Other than the unincorporated business we have just talked about?)

YES NO

G13. How much did you (HEAD) earn altogether from wages or salaries in 1987, that is, before anything was deducted for taxes or other things?
\$ V14913 (Edited) IN 1987

G14. In addition to this, did you have any income from bonuses, overtime, tips, or commissions?
 YES NO GO TO G18
G15. How much was that?
\$ V14915 (Edited) IN 1987

G16. Did you have any income from bonuses, overtime, tips, or commissions?
 YES NO GO TO G18
G17. How much was that?
\$ V14915 (Edited) IN 1987

G18. I'm going to read you a list of other sources of income you might have had. Did you (HEAD) receive any other income in 1987 from professional practice or trade?

	G18	G19 How much was it?	G20 During which months of 1987 did you get this income?	G21 [INTERVIEWER: DID YOU GET WORK HOURS FOR THIS INCOME?]
a. PROFESSIONAL PRACTICE OR TRADE	NO YES	\$ V14916 (Edited) PER _____	ALL OR FROM _____ THRU _____ FROM _____ THRU _____	YES NO
b. farming or market gardening?	NO YES	LABOR=V14917 ASSET=V14924 \$(Edited Vars.) PER _____	ALL OR FROM _____ THRU _____ FROM _____ THRU _____	YES NO
c. roomers or boarders?	NO YES	LABOR=V14918 ASSET=V14925 \$(Edited Vars.) PER _____	ALL OR FROM _____ THRU _____ FROM _____ THRU _____	YES NO

1) A ROOMER OR BOARDER MUST BE A NON-FU MEMBER;
2) SOMEONE IN THIS FU MUST DO WORK FOR THIS MONEY; AND
3) THESE WORK HOURS SHOULD HAVE BEEN REPORTED IN SECTION B OR C.

THESE WORK HOURS MUST BE REPORTED IN SECTION B OR C!

G22. INTERVIEWER CHECKPOINT

SEE B82, (P. 14) OR C74, (P. 26)--EXTRA JOBS IN 1987

A. EXTRA JOB IN 1987 B. ALL OTHERS → GO TO G25

G23! Have you included your earnings from the extra job(s) in the amounts we just talked about?

YES

NO

G24. How much did you earn from your extra jobs in 1987?
\$ V14913 (Edited) FROM EXTRA JOBS IN 1987

G25. Did you (HEAD) receive any other income in 1987 from rent?

WIFE'S SHARE OF ASSETS=Edited V14926

G25		G26		G27	
		How much was it?		During which months of 1987 did you get this income?	
a. RENT	NO	V14928 (Edited) \$ _____ PER _____	ALL	OR	FROM _____ THRU _____ V14927 (Edited)
	YES				
b. dividends, interest, trust funds, or royalties?	NO	V14930 (Edited) \$ _____ PER _____	ALL	OR	FROM _____ THRU _____ V14929 (Edited)
	YES				

G28. Did you (HEAD) receive any income in 1987 from ADC or AFDC?

G28		G29		G30	
		How much was it?		During which months of 1987 did you get this income?	
a. ADC, AFDC	NO	V14943 (Edited) \$ _____ PER _____	ALL	OR	FROM _____ THRU _____ V14986-V14997 (Edited Vars.)
	YES				
b. Supplemental Security Income?	NO	V14946 (Edited) \$ _____ PER _____	ALL	OR	FROM _____ THRU _____ V14945 (Edited)
	YES				
c. other welfare?	NO	V14947 (Edited) \$ _____ PER _____	ALL	OR	FROM _____ THRU _____ V14998-V15009 (Edited Vars.)
	YES				

G31. Did you (HEAD) (or anyone else in the family there) receive any income in 1987 from Social Security?

YES

NO → GO TO G37

	1st PERSON SEQ #	2nd PERSON SEQ #	3rd PERSON SEQ #
G32. (Who was that?)	RELATION TO HEAD	PERSON NUMBER	RELATION TO HEAD
*G33. Was that disability, retirement, survivor's benefits, or what? HEAD=V14950 (Edited) WIFE=V14971 (Edited) ALL SOCIAL SECURITY RECEIVED BY ANY FU MEMBER MUST BE REPORTED HERE	1. DISABILITY	1. DISABILITY	1. DISABILITY
	2. RETIREMENT	2. RETIREMENT	2. RETIREMENT
	3. SURVIVOR'S BENEFITS	3. SURVIVOR'S BENEFITS	3. SURVIVOR'S BENEFITS
	OTHER (SPECIFY):	OTHER (SPECIFY):	OTHER (SPECIFY):
*G34. How much was it?	HEAD=V14949 \$ (Edited)	WIFE=V14970 \$ (Edited)	\$ _____
G35. During which months of 1987 did (you/he/she) get this income? HEAD=V14948 (Edited) WIFE=V14969 (Edited)	PER	PER	PER
	ALL OR FROM THRU	ALL OR FROM THRU	ALL OR FROM THRU
G36. Did anyone else receive any income from Social Security in 1987?	YES NO ASK GO TO G32-G36 G37 AGAIN	YES NO ASK GO TO G32-G36 G37 AGAIN	YES NO ASK GO TO G32-G36 G37 AGAIN

G37. Did you (HEAD) receive any income in 1987 from the Veteran's Administration for a serviceman's, (widow's,) or survivor's pension, service disability, or the GI bill?

YES

NO → NEXT PAGE, G40

G38. How much was it? \$ V14952 (Edited) PER _____

G39. During which months of 1987 did you get this income?
 ALL OR FROM _____ THRU V14951 (Edited)

G40. Did you (HEAD) receive any income in 1987 from other retirement pay, pensions, or annuities?



G41. How much was it? \$ V14954 (Edited) PER _____

G42. During which months of 1987 did you get this income?
 ALL OR FROM _____ THRU V14953 (Edited)

G43. How many of these other pensions (not including Veterans Administration pensions) did you get?
 V14955 (Edited) TOTAL NUMBER OF NON-VA PENSIONS _____

G44. Did you (HEAD) receive any income in 1987 from unemployment compensation?

G45 During which months of 1987 did you get this income?
 G46 How much was it?

	G44		G45		G46	
	NO	YES	How much was it?	During which months of 1987 did you get this income?		
a. UNEMPLOYMENT COMPENSATION			V14956 (Edited) \$ _____ PER _____	<input type="checkbox"/> ALL <input type="checkbox"/> OR V15010-V15021 (Edited Vars.) FROM _____ THRU _____		
b. workers compensation?			V14957 (Edited) \$ _____ PER _____	<input type="checkbox"/> ALL <input type="checkbox"/> OR V15034-V15045 (Edited Vars.) FROM _____ THRU _____		
c. alimony?			V14932 (Edited) \$ _____ PER _____	<input type="checkbox"/> ALL <input type="checkbox"/> OR V14931 (Edited) FROM _____ THRU _____		
d. child support?			V14959 (Edited) \$ _____ PER _____	<input type="checkbox"/> ALL <input type="checkbox"/> OR V14958 (Edited) FROM _____ THRU _____		
e. help from relatives?			V14961 (Edited) \$ _____ PER _____	<input type="checkbox"/> ALL <input type="checkbox"/> OR V14960 (Edited) FROM _____ THRU _____		
f. Anything else? (SPECIFY):			V14963 (Edited) \$ _____ PER _____	<input type="checkbox"/> ALL <input type="checkbox"/> OR V14962 (Edited) FROM _____ THRU _____		

G47. Did anyone (else) not living with you help you (and your family) out by giving you money during 1987?



G48. How much did that amount to last year? \$ V14963 (Edited)
 MONEY FROM OTHERS IN 1987
 #MONTHS RECEIVED=V14962

G49. INTERVIEWER CHECKPOINT

SEE FU LISTING, (P. 2 OF COVER SHEET)

- A. WIPE/"WIFE" IN FU NOW
- B. ALL OTHERS → TURN TO P. 61, G64

G50. Did your (wife/"WIFE") receive any income during 1987?



G51. Was any of it earnings from her work?



G52. How much did she earn altogether from work in 1987, that is, before anything was deducted for taxes or other things?

\$ V14920 (Edited)
 TOTAL EARNINGS FROM WORK IN 1987

WORK HOURS MUST BE REPORTED IN SECTION D OR E FOR THIS INCOME

G53. Did she receive any unemployment compensation in 1987?

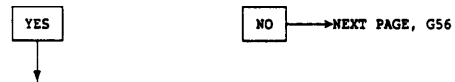

G54. How much was that? V14976 (Edited) UNEMPLOYMENT COMPENSATION IN 1987

G55. During which months of 1987 did she get this income?

ALL OR FROM _____ THRU V15022-V15033 (Edited Vars.)

G56. Did she receive any workers compensation in 1987?

YES NO → GO TO G59

G57. How much was that? \$V14977 (Edited) WORKERS COMPENSATION IN 1987

G58. During which months of 1987 did she get this income?
 ALL OR FROM _____ THRU V15046-V15057 (Edited Vars.)

G59. Did she receive any (other) income in 1987 from interest, welfare, pensions, child support, or any other source?

YES NO → NEXT PAGE, G64

	FIRST SOURCE	SECOND SOURCE
G60. What was it from?	Edited Vars 14933,14964,14967	14968,14973,
G61. How much did that amount to in 1987?	14975,14979,14981,14983 \$ _____ IN 1987	\$ _____ IN 1987
G62. During which months of 1987 did she get this income? EDITED VARS. 14966,14972, 14974,14978,14980,14982	<input type="checkbox"/> ALL <input type="checkbox"/> OR FROM _____ THRU _____	<input type="checkbox"/> ALL <input type="checkbox"/> OR FROM _____ THRU _____
G63. Any other income?	<input type="checkbox"/> YES <input type="checkbox"/> NO ASK G60-G63 NEXT PAGE, AGAIN G64	<input type="checkbox"/> YES <input type="checkbox"/> NO ASK G60-G63 NEXT PAGE, AGAIN G64

TOTAL HEAD & WIFE/"WIFE" TAXABLE INCOME=Edited V14935.
 TOTAL TRANSFERS OF HEAD & WIFE/"WIFE"=Edited V14985

(DO NOT WRITE IN THIS SPACE)

HEAD TYPE INCOME:

TAXABLE	TRANSFER
•L A	• <input type="checkbox"/> <input type="checkbox"/>

(DO NOT WRITE IN THIS SPACE)

WIFE TYPE INCOME:

TAXABLE	TRANSFER
•L A	• <input type="checkbox"/> <input type="checkbox"/>

G64. INTERVIEWER CHECKPOINT: SEE FU LISTING, P. 2 OF COVER SHEET

THIS IS REINTERVIEW (AQUA) COVER SHEET AND 1987 OFUM LABEL HAS BEEN AFFIXED TO G71 GRID

THIS IS SPLITOFF (PINK) COVER SHEET

G65. DID SOMEONE MOVE IN OR OUT OR DIE? G70. IS SOMEONE OTHER THAN THIS YEAR'S HEAD OR WIFE/"WIFE" INCLUDED IN FU?

NO GO TO G72 YES

NO GO TO G72 YES

G66. DID LAST YEAR'S HEAD OR WIFE/"WIFE" MOVE OUT OR DIE?
 NO YES → ADD TO GRID

G67. DID SOMEONE OTHER THAN THIS YEAR'S HEAD OR WIFE/"WIFE" MOVE INTO FU?
 NO YES

GO TO G72 G68. DID THESE PERSONS MOVE IN BEFORE JANUARY 1, 1988?
 NO YES

OTHERS' TOTAL WORK HOURS=Edited V15084
 OTHERS' TOTAL TAXABLE INCOME=Edited V15085
 TRANSFERS OTHER (COMPONENTS)=Edited Vs. 15089-15099 GO TO G72

TOTAL TRANSFERS OF OTHERS=Edited V15101
 TOTAL TRANSFERS OF OTHERS (NOT PRORATED)=Edited V15100

G69. ARE THESE PERSONS 16 YEARS OLD OR OLDER?
 NO GO TO G72 YES

ADD TO GRID

G71. 1987 OFUM (OTHER FAMILY UNIT MEMBER) GRID

OTHER FU MEMBER	RELATIONSHIP TO HEAD	CURRENT AGE	PERSON NUMBER
A			
B			
C			
D			
E			
F			
G			
H			

G72. INTERVIEWER CHECKPOINT

SEE G71 GRID ABOVE--DELETE:

a) ALL PRELISTED PERSONS STILL 15 OR YOUNGER
 b) PRELISTED G'FRIEND/B'FRIEND WHO IS NOW HEAD/WIFE/"WIFE"

IS SOMEONE STILL LISTED?
 YES → NEXT PAGE, G73 NO → TURN TO P. 68, G92

1987 OTHER PU MEMBER A

G73. RELATIONSHIP TO HEAD _____ AGE _____ PERSON NUMBER _____
SEQ #

G74. INTERVIEWER CHECKPOINT

<input type="checkbox"/> A. THIS PERSON IS DECEASED	<input type="checkbox"/> B. THIS PERSON IS NOT DECEASED
---	---

*G75. We would like to know about what (INDIVIDUAL) does--is (he/she) working now, looking for work, retired, a student, keeping house, or what? [CHECK ALL THAT APPLY.]

<input type="checkbox"/> 1. WORKING NOW	<input type="checkbox"/> 2. ONLY TEMPORARILY LAID OFF	<input type="checkbox"/> 3. LOOKING FOR WORK, UNEMPLOYED	<input type="checkbox"/> 4. RETIRED
<input type="checkbox"/> 5. PERMANENTLY DISABLED	<input type="checkbox"/> 6. KEEPING HOUSE	<input type="checkbox"/> 7. STUDENT	
<input type="checkbox"/> 8. OTHER (SPECIFY): _____		<input type="checkbox"/> 9. DON'T KNOW	

G76. During 1987 did (he/she) have a full-time or part-time job (not counting work around the house)?

<input type="checkbox"/> FULL-TIME JOB	<input type="checkbox"/> PART-TIME JOB	<input type="checkbox"/> DID NOT HAVE A JOB
--	--	---

NEXT PAGE, G83

	FIRST JOB	SECOND JOB
G77. What kind of work did (he/she) usually do?	_____	_____
G78. About how much money did (he/she) earn from that job last year?	\$ _____ IN 1987	\$ _____ IN 1987
G79. About how many weeks did (he/she) work on that job last year?	_____ WEEKS IN 1987	_____ WEEKS IN 1987
G80. During which months was that?	FROM _____ THRU _____	FROM _____ THRU _____
G81. During the weeks that (he/she) worked, about how many hours did (he/she) usually work per week?	_____ HOURS PER WEEK IN 1987	_____ HOURS PER WEEK IN 1987
G82. Did (he/she) have any other jobs in 1987?	<input type="checkbox"/> YES <input type="checkbox"/> NO	<input type="checkbox"/> YES <input type="checkbox"/> NO
	ASK G77- G82 AGAIN NEXT PAGE, G83	ASK G77- G82 AGAIN NEXT PAGE, G83

G83. Did (he/she) have any (other) income, such as pensions, welfare, interest, gifts, or anything else, last year?

<input type="checkbox"/> YES	<input type="checkbox"/> NO → GO TO G88
------------------------------	---

	FIRST	SECOND
G84. What was that from?	_____	_____
G85. How much was that last year?	\$ _____ IN 1987	\$ _____ IN 1987
G86. During which months of 1987 did (he/she) get this income?	<input type="checkbox"/> ALL <i>OR</i>	<input type="checkbox"/> ALL <i>OR</i>
	FROM _____ THRU _____	FROM _____ THRU _____
G87. Any other income?	<input type="checkbox"/> YES <input type="checkbox"/> NO	<input type="checkbox"/> YES <input type="checkbox"/> NO
	ASK G84-G87 AGAIN GO TO G88	ASK G84-G87 AGAIN GO TO G88

*G88. When did (he/she) last attend school?

MONTH	<input type="checkbox"/> 1987	<input type="checkbox"/> 1988	<input type="checkbox"/> OTHER YEAR (SPECIFY): _____
			GO TO G90

*G89. Was (he/she) enrolled as a full-time or part-time student?

<input type="checkbox"/> 1. FULL-TIME STUDENT	<input type="checkbox"/> 3. PART-TIME STUDENT
---	---

*G90. What is the highest grade or year of school that (he/she) has completed?

_____ GRADE/YEAR

G91. INTERVIEWER CHECKPOINT

SEE G71 GRID, (P. 61)

<input type="checkbox"/> A. 2 OR MORE 1987 OFUMS LISTED IN G71 GRID → NEXT PAGE, G73
<input type="checkbox"/> B. ALL OTHERS → TURN TO P. 68, G92

*TYPE TAXABLE: L A	\$ TX • <input type="checkbox"/> <input type="checkbox"/> <input type="checkbox"/> <input type="checkbox"/> <input type="checkbox"/> <input type="checkbox"/>	• WRKHS • <input type="checkbox"/> <input type="checkbox"/> <input type="checkbox"/> <input type="checkbox"/>	• <input type="checkbox"/>
TR • <input type="checkbox"/> <input type="checkbox"/>	• CODE SOCIAL SECURITY FROM G33 AND G35, P. 57	\$ TR • <input type="checkbox"/> <input type="checkbox"/> <input type="checkbox"/> <input type="checkbox"/> <input type="checkbox"/> <input type="checkbox"/>	• <input type="checkbox"/>

1987 OTHER PU MEMBER B

G73. RELATIONSHIP TO HEAD _____ AGE _____ PERSON NUMBER _____
SEQ #

G74. INTERVIEWER CHECKPOINT

A. THIS PERSON IS DECEASED B. THIS PERSON IS NOT DECEASED

*G75. We would like to know about what (INDIVIDUAL) does--is (he/she) working now, looking for work, retired, a student, keeping house, or what? [CHECK ALL THAT APPLY.]

1. WORKING NOW	2. ONLY TEMPORARILY LAID OFF	3. LOOKING FOR WORK, UNEMPLOYED	4. RETIRED
5. PERMANENTLY DISABLED	6. KEEPING HOUSE	7. STUDENT	
8. OTHER (SPECIFY): _____		9. DON'T KNOW	

G76. During 1987 did (he/she) have a full-time or part-time job (not counting work around the house)?

FULL-TIME JOB PART-TIME JOB DID NOT HAVE A JOB
NEXT PAGE, G83

	FIRST JOB	SECOND JOB
G77. What kind of work did (he/she) usually do?	_____	_____
G78. About how much money did (he/she) earn from that job last year?	\$ _____ IN 1987	\$ _____ IN 1987
G79. About how many weeks did (he/she) work on that job last year?	_____ WEEKS IN 1987	_____ WEEKS IN 1987
G80. During which months was that?	FROM _____ THRU _____	FROM _____ THRU _____
G81. During the weeks that (he/she) worked, about how many hours did (he/she) usually work per week?	_____ HOURS PER WEEK IN 1987	_____ HOURS PER WEEK IN 1987
G82. Did (he/she) have any other jobs in 1987?	<input type="checkbox"/> YES <input type="checkbox"/> NO ASK G77- G82 AGAIN NEXT PAGE, G83	<input type="checkbox"/> YES <input type="checkbox"/> NO ASK G77- G82 AGAIN NEXT PAGE, G83

G83. Did (he/she) have any (other) income, such as pensions, welfare, interest, gifts, or anything else, last year?

YES NO → GO TO G88

	FIRST	SECOND
G84. What was that from?	_____	_____
G85. How much was that last year?	\$ _____ IN 1987	\$ _____ IN 1987
G86. During which months of 1987 did (he/she) get this income?	FROM _____ THRU _____ ALL OR	FROM _____ THRU _____ ALL OR
G87. Any other income?	<input type="checkbox"/> YES <input type="checkbox"/> NO ASK G84-G87 AGAIN GO TO G88	<input type="checkbox"/> YES <input type="checkbox"/> NO ASK G84-G87 AGAIN GO TO G88

*G88. When did (he/she) last attend school?

MONTH 1987 1988 OTHER YEAR (SPECIFY): _____
GO TO G90

*G89. Was (he/she) enrolled as a full-time or part-time student?

1. FULL-TIME STUDENT 3. PART-TIME STUDENT

*G90. What is the highest grade or year of school that (he/she) has completed?

_____ GRADE/YEAR

G91. INTERVIEWER CHECKPOINT

SEE G71 GRID, (P. 61)

A. 3 OR MORE 1987 OFUMS LISTED IN G71 GRID → NEXT PAGE, G73
 B. ALL OTHERS → TURN TO P. 68, G92

*TYPE TAXABLE L A

\$ TX • • WRKHS • •

TR • *CODE SOCIAL SECURITY FROM G33 AND G35, P. 57 \$ TR • •

1987 OTHER FU MEMBER C

G73. RELATIONSHIP TO HEAD _____ AGE _____ PERSON NUMBER _____
SEQ #

G74. INTERVIEWER CHECKPOINT

<input type="checkbox"/> A. THIS PERSON IS DECEASED	<input type="checkbox"/> B. THIS PERSON IS NOT DECEASED
---	---

*G75. We would like to know about what (INDIVIDUAL) does--is (he/she) working now, looking for work, retired, a student, keeping house, or what? [CHECK ALL THAT APPLY.]

1. WORKING NOW	2. ONLY TEMPORARILY LAID OFF	3. LOOKING FOR WORK, UNEMPLOYED	4. RETIRED
5. PERMANENTLY DISABLED	6. KEEPING HOUSE	7. STUDENT	
8. OTHER (SPECIFY): _____		9. DON'T KNOW	

G76. During 1987 did (he/she) have a full-time or part-time job (not counting work around the house)?

FULL-TIME JOB	PART-TIME JOB	DID NOT HAVE A JOB
---------------	---------------	--------------------

NEXT PAGE, G83

	FIRST JOB	SECOND JOB
G77. What kind of work did (he/she) usually do?	_____	_____
G78. About how much money did (he/she) earn from that job last year?	\$ _____ IN 1987	\$ _____ IN 1987
G79. About how many weeks did (he/she) work on that job last year?	_____ WEEKS IN 1987	_____ WEEKS IN 1987
G80. During which months was that?	FROM _____ THRU _____	FROM _____ THRU _____
G81. During the weeks that (he/she) worked, about how many hours did (he/she) usually work per week?	_____ HOURS PER WEEK IN 1987	_____ HOURS PER WEEK IN 1987
G82. Did (he/she) have any other jobs in 1987?	<input type="checkbox"/> YES <input type="checkbox"/> NO	<input type="checkbox"/> YES <input type="checkbox"/> NO
	ASK G77- G82 AGAIN NEXT PAGE, G83	ASK G77- G82 AGAIN NEXT PAGE, G83

G83. Did (he/she) have any (other) income, such as pensions, welfare, interest, gifts, or anything else, last year?

YES NO → GO TO G88

	FIRST	SECOND
G84. What was that from?	_____	_____
G85. How much was that last year?	\$ _____ IN 1987	\$ _____ IN 1987
	<input type="checkbox"/> ALL <i>OR</i>	<input type="checkbox"/> ALL <i>OR</i>
G86. During which months of 1987 did (he/she) get this income?	FROM _____ THRU _____	FROM _____ THRU _____
G87. Any other income?	<input type="checkbox"/> YES <input type="checkbox"/> NO ASK G84-G87 AGAIN GO TO G88	<input type="checkbox"/> YES <input type="checkbox"/> NO ASK G84-G87 AGAIN GO TO G88

*G88. When did (he/she) last attend school?

MONTH	1987	1988	OTHER YEAR (SPECIFY): _____
			GO TO G90

*G89. Was (he/she) enrolled as a full-time or part-time student?

1. FULL-TIME STUDENT	3. PART-TIME STUDENT
----------------------	----------------------

*G90. What is the highest grade or year of school that (he/she) has completed?

_____ GRADE/YEAR

G91. INTERVIEWER CHECKPOINT

SEE G71 GRID, (P. 61)

A. 4 OR MORE 1987 OFUMS LISTED IN G71 GRID → TURN TO BLUE 1987 OFUM SUPPLEMENT

B. ALL OTHERS → NEXT PAGE, G92

*TYPE TAXABLE	L	A	
\$ TX	•	•	WRKHS •
TR	•	•	\$ TR
*CODE SOCIAL SECURITY FROM G33 AND G35, P. 57			

ASK EVERYONE

G92. INTERVIEWER CHECKPOINT

SEE FU LISTING, (P. 2 OF COVER SHEET)
 DFUMS IN FU IN 1987:
 A. ARE NOW AGE 15 OR YOUNGER B. ALL OTHERS C. NO DFUMS IN FU
 NEXT PAGE, G99

G93. Did anyone else 15 or younger living there in 1987 have any income in 1987?

YES NO → NEXT PAGE, G99

G94 WHO WAS THAT? [LIST EACH PERSON AND ASK G95-G98]	G95 About how much was that?	G96 What was that from?	G97 [IF WORK MENTIONED AT G96] About how many hours of work was that?	G98 Did anyone else 15 or younger living there in 1987 have any income in 1987?
RELATIONSHIP TO HEAD	\$ _____ IN 1987	_____	HOURS IN 1987	<input type="checkbox"/> YES ASK G94-G98 AGAIN <input type="checkbox"/> NO NEXT PAGE, G99
AGE PERSON NO.				
RELATIONSHIP TO HEAD	\$ _____ IN 1987	_____	HOURS IN 1987	<input type="checkbox"/> YES ASK G94-G98 AGAIN <input type="checkbox"/> NO NEXT PAGE, G99
AGE PERSON NO.				
RELATIONSHIP TO HEAD	\$ _____ IN 1987	_____	HOURS IN 1987	<input type="checkbox"/> YES ASK G94-G98 AGAIN <input type="checkbox"/> NO NEXT PAGE, G99
AGE PERSON NO.				

SEQ #	SEQ #	SEQ #
• TYPE TAXABLE L A	• TYPE TAXABLE L A	• TYPE TAXABLE L A
STX • <input type="checkbox"/> <input type="checkbox"/> <input type="checkbox"/> <input type="checkbox"/> <input type="checkbox"/> <input type="checkbox"/> <input type="checkbox"/> <input type="checkbox"/> <input type="checkbox"/> <input type="checkbox"/>	STX • <input type="checkbox"/> <input type="checkbox"/> <input type="checkbox"/> <input type="checkbox"/> <input type="checkbox"/> <input type="checkbox"/> <input type="checkbox"/> <input type="checkbox"/> <input type="checkbox"/> <input type="checkbox"/>	STX • <input type="checkbox"/> <input type="checkbox"/> <input type="checkbox"/> <input type="checkbox"/> <input type="checkbox"/> <input type="checkbox"/> <input type="checkbox"/> <input type="checkbox"/> <input type="checkbox"/> <input type="checkbox"/>
WRKHS • <input type="checkbox"/> <input type="checkbox"/> <input type="checkbox"/> <input type="checkbox"/> <input type="checkbox"/> <input type="checkbox"/> <input type="checkbox"/> <input type="checkbox"/>	WRKHS • <input type="checkbox"/> <input type="checkbox"/> <input type="checkbox"/> <input type="checkbox"/> <input type="checkbox"/> <input type="checkbox"/> <input type="checkbox"/> <input type="checkbox"/>	WRKHS • <input type="checkbox"/> <input type="checkbox"/> <input type="checkbox"/> <input type="checkbox"/> <input type="checkbox"/> <input type="checkbox"/> <input type="checkbox"/> <input type="checkbox"/>
TYPE TRANSFER • <input type="checkbox"/> <input type="checkbox"/>	TYPE TRANSFER • <input type="checkbox"/> <input type="checkbox"/>	TYPE TRANSFER • <input type="checkbox"/> <input type="checkbox"/>
•CODE SOC SEC FR. G33/G35, P. 57	•CODE SOC SEC FR. G33/G35, P. 57	•CODE SOC SEC FR. G33/G35, P. 57
\$TR • <input type="checkbox"/> <input type="checkbox"/> <input type="checkbox"/> <input type="checkbox"/> <input type="checkbox"/> <input type="checkbox"/>	\$TR • <input type="checkbox"/> <input type="checkbox"/> <input type="checkbox"/> <input type="checkbox"/> <input type="checkbox"/> <input type="checkbox"/>	\$TR • <input type="checkbox"/> <input type="checkbox"/> <input type="checkbox"/> <input type="checkbox"/> <input type="checkbox"/> <input type="checkbox"/>

*G99. Did you (or anyone else in your family living there) get any other money in 1987-- like a big settlement from an insurance company, or an inheritance?

1. YES 5. NO → GO TO G102

*G100. How much did that amount to?

\$ _____ IN 1987 V15770
LUMP SUM

*G101. How much of that was an inheritance?

\$ _____ IN 1987 V15771
INHERITANCE

*G102. Some people have expenses they can itemize and deduct on their income tax. Did you itemize deductions on your 1987 federal income tax, such as property taxes, interest payments, and charitable contributions?

1. YES 5. NO 5. DID/WILL NOT FILE

*G103. Suppose you (and your family living there) were to sell all of your major possessions (including your home), turn all your investments and other assets into cash, and pay all your debts--would you have something left over, break even, or be in debt?

1. HAVE SOMETHING LEFT OVER 3. BREAK EVEN 5. BE IN DEBT

NEXT PAGE, G108

*G104. How much would you have left over?

\$ _____ NEXT PAGE, G108 9999998. DON'T KNOW 9999997. REFUSED V15774
NET WORTH-FU

V15775 *G105. Would it amount to \$25,000 or more?

1. YES 5. NO 8. DON'T KNOW
NEXT PAGE, G108

V15776 *G106. \$100,000 or more?

1. YES 5. NO 8. DK

V15777 *G107. \$1,000 or more?

1. YES 5. NO 8. DK

NEXT PAGE, G108

ESTIMATE OF NET WORTH=V15778

*G108. Now I have some questions about help people sometimes give to others living somewhere else. In 1987, did (you/your family living there) give any money toward the support of anyone who was not living with you at the time?

1. YES 5. NO → TURN TO P. 72, G125

V15780 *G109. How many people did you give money to?

01 02 OTHER:

G110. What is the person's name? G111. So that I can tell these people apart in the next few questions, can you give me their names?
 G112. PRINT NAME(S) ON PEEL-OFF LABEL(S)

• 68ID • PN • REL

*G113. What is (NAME OF PERSON #1's) relationship to you (HEAD)?

CHILD EX-SPOUSE OTHER (SPECIFY):
 PLACE PEEL-OFF LABEL HERE

*G114. Was any of the money you gave (him/her) child support?

1. YES 5. NO

*G115. Was any of the money you gave (him/her) alimony?

1. YES 5. NO

Edited V14936-Support Others
 *G116. How much money did you give (him/her) in 1987? \$ Edited V14937-Child Support
 Edited V14938-Alimony paid
 *G117. Was (NAME OF PERSON #1) dependent on you for more than half of (his/her) total support?
 1. YES 5. NO

G118. INTERVIEWER CHECKPOINT

SEE G112 ABOVE
 MORE PERSONS ON PEEL-OFF LABELS NO MORE SUCH PERSONS
 NEXT PAGE, G119 TURN TO P. 72, G125

OF DEPENDENTS=Edited V14939
 # OF EXEMPTIONS=Edited V14940

• 68ID • PN • REL

*G119. What is (NAME OF PERSON #2's) relationship to you (HEAD)?

CHILD EX-SPOUSE OTHER (SPECIFY):
 PLACE PEEL-OFF LABEL HERE

*G120. Was any of the money you gave (him/her) child support?

1. YES 5. NO

*G121. Was any of the money you gave (him/her) alimony?

1. YES 5. NO

Edited V14936-Support Others
 *G122. How much money did you give (him/her) in 1987? \$ Edited V14937-Child Support
 *G123. Was (NAME OF PERSON #2) dependent on you for more than half of (his/her) total support?
 1. YES 5. NO

G124. INTERVIEWER CHECKPOINT

SEE G112, (P. 70)
 MORE PERSONS ON PEEL-OFF LABELS NO MORE SUCH PERSONS
 REPEAT G119-G123 FOR EACH ADDITIONAL PERSON ON PEEL-OFF LABEL NEXT PAGE, G125

VARIABLES GENERATED FROM THIS SEQUENCE:

V15781-V15803, MONEY HELP GIVEN TO RELATIVES BY TYPE OF RELATIONSHIP
 (See tape code for details.)

*G125. Now we would like to ask some questions about your (HEAD'S) parents. First your father [INCLUDE ADOPTIVE FATHERS BUT NOT STEPPATHERS]--can you give me his name? [PRINT NAME ON PEEL-OFF LABEL.]

681D PN
 V15805=1988 ID OF FATHER PLACE PEEL-OFF LABEL HERE

*G126. Is your father alive?
V15804

1. YES 5. NO

*G129. In what month and year did he die?

V15809 V15810
MONTH YEAR

*G130. In what month and year was he born?

MONTH YEAR DK
NEXT PAGE, G134

*G131. How old was he when he died?

V15811
NEXT PAGE, G134

*G127. In what month and year was he born?

V15806 V15807
MONTH YEAR DK

*G128. How old is he now? V15808

*G132. Compared to other people his age, is his health excellent, very good, good, fair, or poor?
V15812

1. EXCELLENT 2. VERY GOOD 3. GOOD 4. FAIR 5. POOR

*G133. (Even if a person's overall health is good, they may have a health condition that requires a lot of extra care.) Does your father require a lot of extra care because of a health condition?
V15813

1. YES 5. NO

*G134. Now your (HEAD'S) mother [INCLUDE ADOPTIVE MOTHERS BUT NOT STEPMOTHERS]--can you give me her name? [PRINT NAME ON PEEL-OFF LABEL.]

681D PN
 V15819=1988 ID OF MOTHER PLACE PEEL-OFF LABEL HERE

*G135. Is your mother alive?
V15818

1. YES 5. NO

*G138. In what month and year did she die?

V15823 V15824
MONTH YEAR

*G139. In what month and year was she born?

MONTH YEAR DK
GO TO G143

*G140. How old was she when she died?

V15825
GO TO G143

*G136. In what month and year was she born?

V15820 V15821
MONTH YEAR DK

*G137. How old is she now? V15822

*G141. Compared to other people her age, is her health excellent, very good, good, fair, or poor?
V15826

1. EXCELLENT 2. VERY GOOD 3. GOOD 4. FAIR 5. POOR

*G142. (Even if a person's overall health is good, they may have a health condition that requires a lot of extra care.) Does she require a lot of extra care because of a health condition?
V15827

1. YES 5. NO

G143. INTERVIEWER CHECKPOINT

SEE G126, (P. 72) AND G135 ABOVE

BOTH FATHER & MOTHER ARE LIVING NEXT PAGE, G144	ONLY FATHER LIVING TURN TO P. 77, G170	ONLY MOTHER LIVING TURN TO P. 80, G196	NEITHER IS LIVING TURN TO P. 83, G223
--	---	---	--

VARIABLES GENERATED FROM THIS SEQUENCE, G144-C222--HEAD'S PARENTS: V15814-V15817, V15828-V15860 (See tape code for details.)

*G144. Are your parents still married to each other?

1. YES 5. NO → TURN TO P. 77, G170 8. DON'T KNOW → TURN TO P. 83, G223

*G145. Are they living with you now, in their home somewhere else, in another relative's home, in a nursing home, or what?

1. LIVING IN FU NOW → NEXT PAGE, G159 2. LIVING IN HU NOW → GO TO G148

3. IN OWN HOME SOMEWHERE ELSE	4. IN OTHER RELATIVE'S HOUSE	5. IN NURSING HOME	6. NOT LIVING TOGETHER	7. OTHER (SPECIFY): _____ _____ _____
-------------------------------------	------------------------------------	--------------------------	------------------------------	--

*G146. About how far away from your house do they live? Is it less than one mile, one to ten miles, eleven to 100 miles, or over 100 miles?

1. LESS THAN
1 MILE 2. 1-10
MILES 3. 11-100
MILES 4. OVER 100
MILES

*G147. What state or country do they live in [MOST OF THE TIME]?

ST-MO & FA

*G148. Now about your parents' total yearly income from all sources including such things as jobs, Social Security, and pensions, how much income did they receive in 1987?

9999998. DON'T KNOW 9999997. REFUSED INCOME-MO & FA

*G149. Would it amount to \$20,000 or more?

1. YES 5. NO 8. DK → NEXT PAGE, G152

*G150. \$50,000 or more?

1. YES 5. NO 8. DK

*G151. \$5,000 or more?

1. YES 5. NO 8. DK

NEXT PAGE, G152

*G152. Do they own their home, pay rent, or what?

1. OWN OR ARE BUYING 5. PAY RENT 8. NEITHER OWN NOR RENT

GO TO G159

*G153. Could you tell me what the present value of their home is--I mean, about how much would it bring if sold today?

999998. DK 999997. REFUSED HOUSE VALUE-MO & FA

*G154. Would it amount to \$50,000 or more?

1. YES 5. NO 8. DK → GO TO G158

*G155. \$100,000 or more?

1. YES 5. NO 8. DK

GO TO G158

*G157. \$25,000 or more?

1. YES 5. NO 8. DK

*G156. \$150,000 or more?

1. YES 5. NO 8. DK

*G158. Do they have a mortgage on their home?

1. YES 5. NO 8. DON'T KNOW

*G159. People sometimes need help from others--either time or money. Let's start by talking about help in the form of time, either in an emergency or with everyday activities such as errands, housework, small repairs to a car or baby-sitting. In 1987, did (you/your family living there) spend a lot of time helping your parents?

1. YES 5. NO → NEXT PAGE, G161

*G160. About how many hours in 1987 did (you/your family living there) spend helping them?

HOURS IN 1987

*G161. How about time they spent helping you? In 1987, did your (HEAD'S) parents spend a lot of time helping (you/your family living there)?

1. YES 5. NO → GO TO G163

*G162. About how many hours in 1987 did they spend helping (you/your family living there)?

_____ HOURS IN 1987

*G163. During 1987, did (you/your family living there) receive any loans, gifts, or support worth \$100 or more from your parents?

1. YES 5. NO → GO TO G165

*G164. About how much were those loans, gifts, or support worth altogether in 1987?

\$ _____ IN 1987

*G165. Suppose your parents were to sell all of their major possessions (including their home), turn all their investments and other assets into cash, and pay all their debts. Would they have something left over, break even, or be in debt?

1. HAVE SOMETHING LEFT OVER 3. BREAK EVEN 5. BE IN DEBT

TURN TO P. 83, G223

*G166. How much would they have left over?

\$ _____ NEXT PAGE, G223

9999998. DON'T KNOW 9999997. REFUSED • [] [] [] [] [] [] [] [] [] []

NET WORTH-MO & FA

*G167. Would it amount to \$25,000 or more?

1. YES 5. NO 8. DK → TURN TO P. 83, G223

*G168. \$100,000 or more? *G169. \$1,000 or more?

1. YES 5. NO 8. DK 1. YES 5. NO 8. DK

TURN TO P. 83, G223

*G170. Is your (HEAD'S) father currently married to someone else?

1. YES 5. NO 8. DON'T KNOW → TURN TO P. 80, G196

*G171. (Is your father/Are your father and stepmother) living with you now, in (his/their) home somewhere else, in another relative's home, in a nursing home, or what?

1. LIVING IN FU NOW → NEXT PAGE, G185 2. LIVING IN HU NOW → GO TO G174

3. IN OWN HOME SOMEWHERE ELSE	4. IN OTHER RELATIVE'S HOUSE	5. IN NURSING HOME	6. NOT LIVING TOGETHER	7. OTHER (SPECIFY): _____ _____ _____
-------------------------------	------------------------------	--------------------	------------------------	--

*G172. About how far away from your house (does he/do they) live? Is it less than one mile, one to ten miles, eleven to 100 miles, or over 100 miles?

1. LESS THAN 1 MILE 2. 1-10 MILES 3. 11-100 MILES 4. OVER 100 MILES

*G173. What state or country (does he/do they) live in [MOST OF THE TIME]? ST-FA

*G174. Now about your father's (and stepmother's) total yearly income from all sources including such things as jobs, Social Security, and pensions, how much income did (he/they) receive in 1987?

\$ _____ NEXT PAGE, G178

9999998. DON'T KNOW 9999997. REFUSED • [] [] [] [] [] [] [] [] [] []

INCOME-FA

*G175. Would it amount to \$25,000 or more?

1. YES 5. NO 8. DK → NEXT PAGE, G178

*G176. \$50,000 or more? *G177. \$5,000 or more?

1. YES 5. NO 8. DK 1. YES 5. NO 8. DK

NEXT PAGE, G178

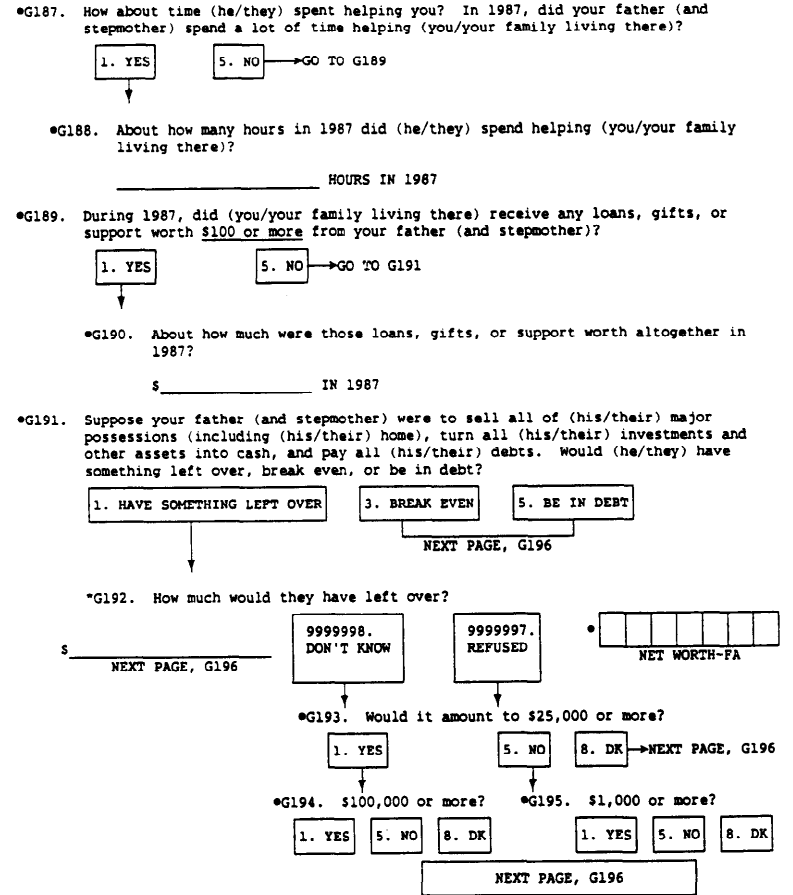
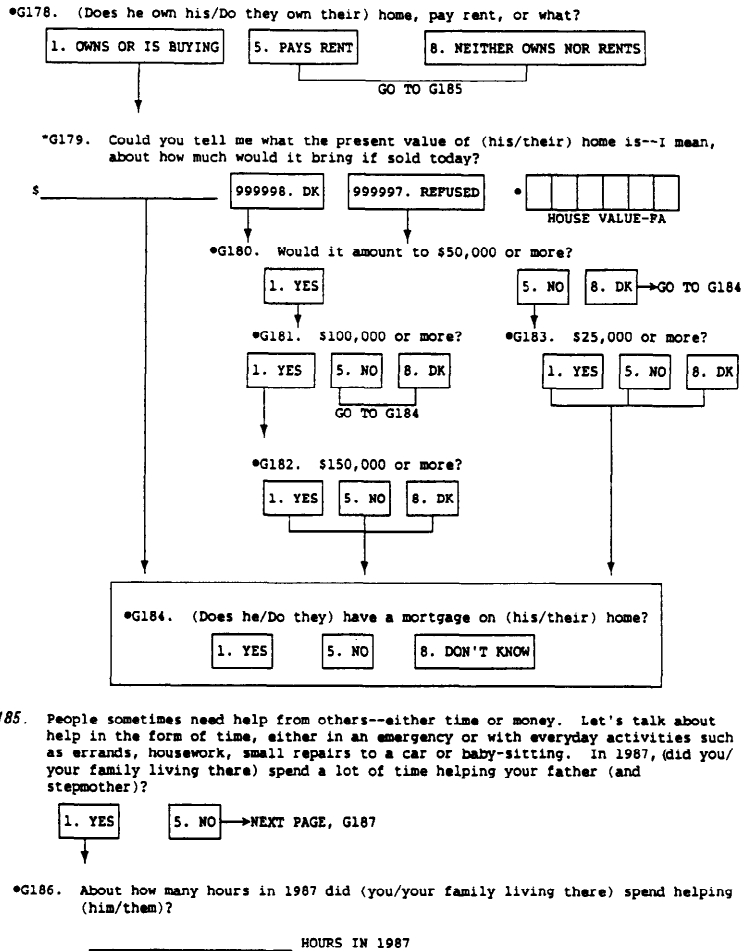

G196. INTERVIEWER CHECKPOINT

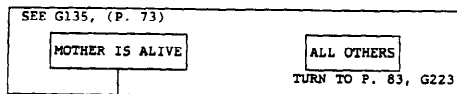

*G197. Is your (HEAD'S) mother currently married to someone else?

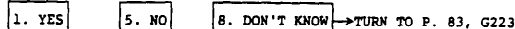

*G198. (Is your mother/Are your mother and stepfather) living with you now, in (her/their) home somewhere else, in another relative's home, in a nursing home, or what?

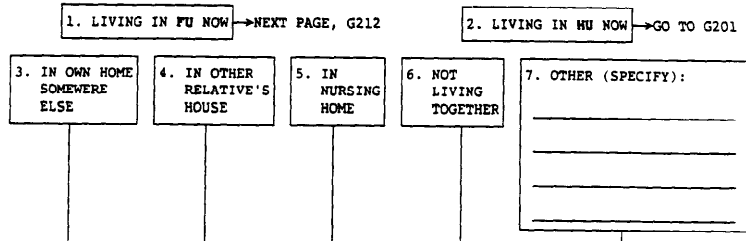

*G199. About how far away from your house (does he/do they) live? Is it less than one mile, one to ten miles, eleven to 100 miles, or over 100 miles?

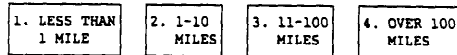

*G200. What state or country (does she/do they) live in [MOST OF THE TIME]? ST-MO

*G201. Now about your mother's (and stepfather's) total yearly income from all sources including such things as jobs, Social Security, and pensions, how much income did (she/they) receive in 1987?

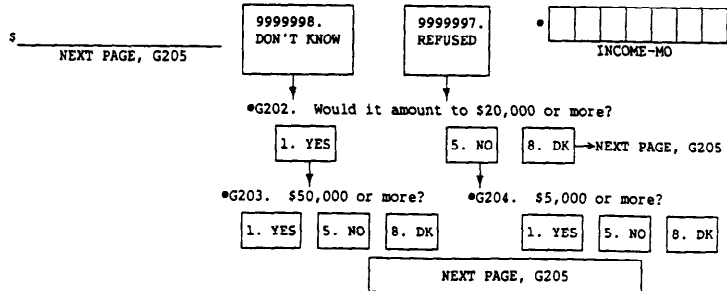

*G205. (Does she own her/Do they own their) home, pay rent, or what?



*G206. Could you tell me what the present value of (her/their) home is--I mean, about how much would it bring if sold today?

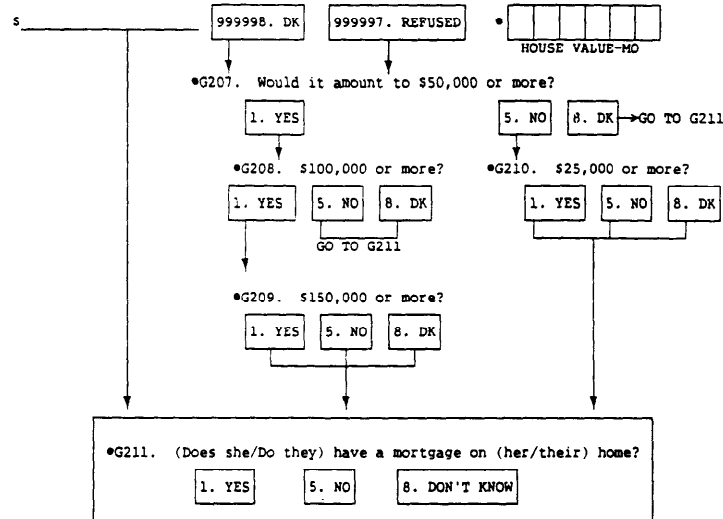

*G212. (People sometimes need help from others--either time or money.) Let's talk about help in the form of time, either in an emergency or with everyday activities such as errands, housework, small repairs to a car or baby-sitting. In 1987, did (you/your family living there) spend a lot of time helping your mother (and stepfather)?

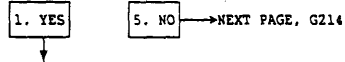

*G213. About how many hours in 1987 did (you/your family living there) spend helping (her/them)?

_____ HOURS IN 1987

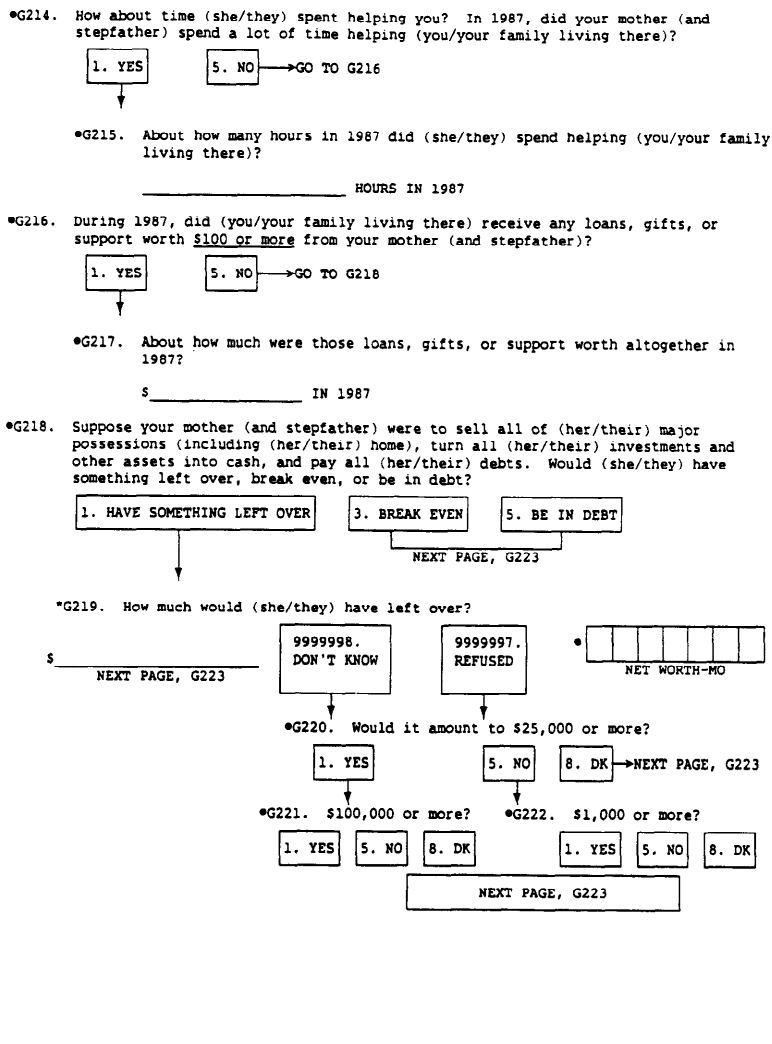

G223. INTERVIEWER CHECKPOINT

SEE FAMILY LISTING, (P. 2 OF COVER SHEET)

WIFE/"WIFE" IN FU NOW NO WIFE/"WIFE" IN FU NOW

TURN TO P. 94, G322

*G224. Now we would like to ask some questions about your (wife's/"WIFE'S") parents. First her father [INCLUDE ADOPTIVE FATHERS BUT NOT STEPPATHERS]--can you give me his name? [PRINT NAME ON PEEL-OFF LABEL.]

68ID PN

PLACE PEEL-OFF LABEL HERE

*G225. Is her father alive? V15862=1988 ID OF FATHER

1. YES 5. NO

*G228. In what month and year did he die?

V15866 V15867
MONTH YEAR

*G229. In what month and year was he born?

MONTH YEAR DK

NEXT PAGE, G233

*G230. How old was he when he died?

V15868
NEXT PAGE, G233

*G226. In what month and year was he born?

V15863 V15864
MONTH YEAR

DK

*G227. How old is he now?

V15865

*G231. Compared to other people his age, is his health excellent, very good, good, fair, or poor?

1. EXCELLENT 2. VERY GOOD 3. GOOD 4. FAIR 5. POOR

*G232. (Even if a person's overall health is good, they may have a health condition that requires a lot of extra care.) Does her father require a lot of extra care because of a health condition?

1. YES 5. NO

*G233. Now her mother [INCLUDE ADOPTIVE MOTHERS BUT NOT STEPMOTHERS]--can you give me her mother's name? [PRINT NAME ON PEEL-OFF LABEL.]

• •

68ID PN

PLACE PEEL-OFF LABEL HERE

*G234. Is her mother alive?
V15875

1. YES 5. NO

V15876=1988 ID OF MOTHER

*G237. In what month and year did her mother die?

V15880 MONTH V15881 YEAR

*G238. In what month and year was her mother born?

MONTH YEAR DK
GO TO G242

*G239. How old was she when she died?

V15892
GO TO G242

*G235. In what month and year was her mother born?

V15877 MONTH V15878 YEAR

DK

*G236. How old is she now? V15879

*G240. Compared to other people her age, is her mother's health excellent, very good, good, fair, or poor?
V15883

1. EXCELLENT 2. VERY GOOD 3. GOOD 4. FAIR 5. POOR

*G241. (Even if a person's overall health is good, they may have a health condition that requires a lot of extra care.) Does she require a lot of extra care because of a health condition?
V15884

1. YES 5. NO

G242. INTERVIEWER CHECKPOINT

SEE G225, (P. 83) AND G234 ABOVE

BOTH FATHER & MOTHER ARE LIVING NEXT PAGE, G243	ONLY FATHER LIVING TURN TO P. 88, G269	ONLY MOTHER LIVING TURN TO P. 91, G295	NEITHER IS LIVING TURN TO P. 94, G322
--	---	---	--

VARIABLES GENERATED FROM THIS SEQUENCE, G243-G321--WIFE'S/"WIFE'S" PARENTS: V15871-V15874, V15885-V15917 (See tape code for details.)

*G243. Are her parents still married to each other?

1. YES 5. NO → TURN TO P. 88, G269 8. DON'T KNOW → TURN TO P. 94, G322

*G244. Are her parents living with you now, in their home somewhere else, in another relative's home, in a nursing home, or what?

1. LIVING IN FU NOW → NEXT PAGE, G258 2. LIVING IN NU NOW → GO TO G247

3. IN OWN HOME SOMEWHERE ELSE	4. IN OTHER RELATIVE'S HOUSE	5. IN NURSING HOME	6. NOT LIVING TOGETHER	7. OTHER (SPECIFY): _____ _____ _____
-------------------------------	------------------------------	--------------------	------------------------	--

*G245. About how far away from your house do they live? Is it less than one mile, one to ten miles, eleven to 100 miles, or over 100 miles?

1. LESS THAN 1 MILE 2. 1-10 MILES 3. 11-100 MILES 4. OVER 100 MILES

*G246. What state or country do they live in [MOST OF THE TIME]? ST-WF FA & MO

*G247. Now about her parents' total yearly income from all sources including such things as jobs, Social Security, and pensions, how much income did they receive in 1987?

\$ _____ NEXT PAGE, G251

9999998. DON'T KNOW 9999997. REFUSED

INCOME-WF FA & MO

*G248. Would it amount to \$20,000 or more?

1. YES 5. NO 8. DK → NEXT PAGE, G251

*G249. \$50,000 or more? *G250. \$5,000 or more?

1. YES 5. NO 8. DK 1. YES 5. NO 8. DK

NEXT PAGE, G251

*G251. Do they own their home, pay rent, or what?
 1. OWN OR ARE BUYING 5. PAY RENT 8. NEITHER OWN NOR RENT

GO TO G258

*G252. Could you tell me what the present value of their home is--I mean, about how much would it bring if sold today?

\$ _____
 999998. DK 999997. REFUSED • _____
 HOUSE VALUE-WF FA & MO

*G253. Would it amount to \$50,000 or more?
 1. YES 5. NO 8. DK → GO TO G257

*G254. \$100,000 or more?
 1. YES 5. NO 8. DK
 GO TO G257

*G256. \$25,000 or more?
 1. YES 5. NO 8. DK

*G255. \$150,000 or more?
 1. YES 5. NO 8. DK

*G257. Do they have a mortgage on their home?
 1. YES 5. NO 8. DON'T KNOW

*G258. About help in the form of time, either in an emergency or with everyday activities such as errands, housework, small repairs to a car or baby-sitting. In 1987, did your family living there spend a lot of time helping your (wife's/"WIFE'S") parents?

1. YES 5. NO → NEXT PAGE, G260

*G259. About how many hours in 1987 did your family living there spend helping them?
 _____ HOURS IN 1987

*G260. How about time they spent helping you? In 1987, did your (wife's/"WIFE'S") parents spend a lot of time helping your family living there?

1. YES 5. NO → GO TO G262

*G261. About how many hours in 1987 did they spend helping your family living there?

_____ HOURS IN 1987

G262. During 1987, did your family living there receive any loans, gifts, or support worth \$100 or more from your (wife's/"WIFE'S") parents?

1. YES 5. NO → GO TO G264

*G263. About how much were those loans, gifts, or support worth altogether in 1987?

\$ _____ IN 1987

*G264. Suppose your (wife's/"WIFE'S") parents were to sell all of their major possessions (including their home), turn all their investments and other assets into cash, and pay all their debts. Would they have something left over, break even, or be in debt?

1. HAVE SOMETHING LEFT OVER 3. BREAK EVEN 5. BE IN DEBT
 TURN TO P. 94, G322

*G265. How much would they have left over?

\$ _____
 9999998. DON'T KNOW 9999997. REFUSED • _____
 NET WORTH-WF FA & MO
 TURN TO P. 94, G322

*G266. Would it amount to \$25,000 or more?

1. YES 5. NO 8. DON'T KNOW
 TURN TO P. 94, G322

*G267. \$100,000 or more?

1. YES 5. NO 8. DK

*G268. \$1,000 or more?

1. YES 5. NO 8. DK

TURN TO P. 94, G322

*G269. Is your (wife's/"WIFE'S") father currently married to someone else?

1. YES 5. NO 8. DON'T KNOW → TURN TO P. 91, G295

*G270. (Is her father/Are her father and stepmother) living with you now, in (his/their) home somewhere else, in another relative's home, in a nursing home, or what?

1. LIVING IN FU NOW → NEXT PAGE, G284 2. LIVING IN HU NOW → GO TO G273
3. IN OWN HOME SOMEWHERE ELSE 4. IN OTHER RELATIVE'S HOUSE 5. IN NURSING HOME 6. NOT LIVING TOGETHER 7. OTHER (SPECIFY):

*G271. About how far away from your house (does he/do they) live? Is it less than one mile, one to ten miles, eleven to 100 miles, or over 100 miles?

1. LESS THAN 1 MILE 2. 1-10 MILES 3. 11-100 MILES 4. OVER 100 MILES

*G272. What state or country (does he/do they) live in [MOST OF THE TIME]? ST-WF FA

*G273. Now about her father's (and stepmother's) total yearly income from all sources (including such things as jobs, Social Security, and pensions), how much income did (he/they) receive in 1987?

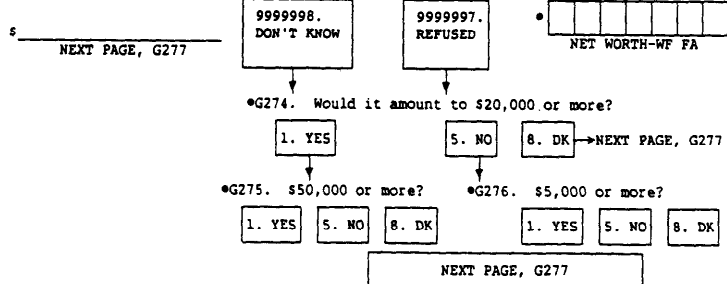

*G277. (Does he own his/Do they own their) home, pay rent, or what?

1. OWNS OR IS BUYING 5. PAYS RENT 8. NEITHER OWNS NOR RENTS
- GO TO G284

*G278. Could you tell me what the present value of (his/their) home is--I mean, about how much would it bring if sold today?

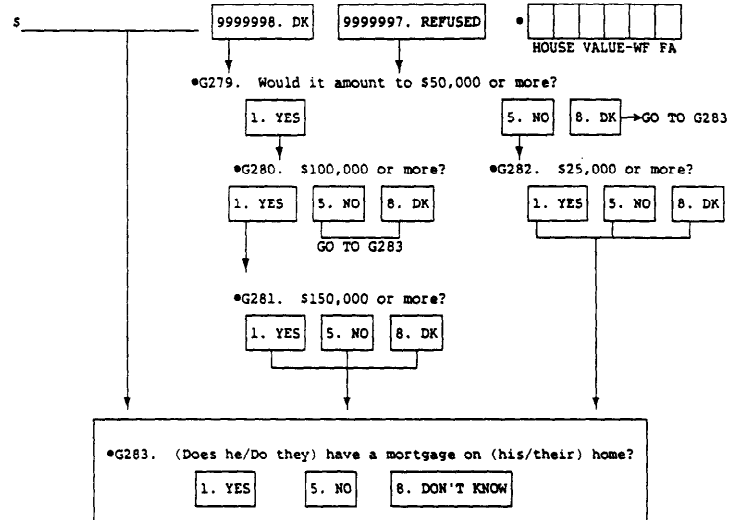

*G284. About help in the form of time, either in an emergency or with everyday activities such as errands, housework, small repairs to a car or baby-sitting. In 1987, did your family living there spend a lot of time helping your (wife's/"WIFE'S") father (and stepmother)?

1. YES 5. NO → NEXT PAGE, G286

*G285. About how many hours in 1987 did (you/your family living there) spend helping (him/them)?

_____ HOURS IN 1987

*G286. How about time (he/they) spent helping you? In 1987, did your (wife's/"WIFE'S") father (and stepmother) spend a lot of time helping your family living there?

- 1. YES 5. NO ->GO TO G288

*G287. About how many hours in 1987 did (he/they) spend helping your family living there?

_____ HOURS IN 1987

*G288. During 1987, did your family living there receive any loans, gifts, or support worth \$100 or more? from your (wife's/"WIFE'S") father (and stepmother)?

- 1. YES 5. NO ->GO TO G290

*G289. About how much were those loans, gifts, or support worth altogether in 1987?

\$ _____ IN 1987

*G290. Suppose your (wife's/"WIFE'S") father (and stepmother) were to sell all of (his/their) major possessions (including (his/their) home), turn all (his/their) investments and other assets into cash, and pay all (his/their) debts. Would (he/they) have something left over, break even, or be in debt?

- 1. HAVE SOMETHING LEFT OVER 3. BREAK EVEN 5. BE IN DEBT

NEXT PAGE, G295

*G291. How much would (he/they) have left over?

\$ _____ NET WORTH-WF FA

NEXT PAGE, G295

9999998. DON'T KNOW 9999997. REFUSED

*G292. Would it amount to \$25,000 or more?

- 1. YES 5. NO 8. DK ->NEXT PAGE, G295

*G293. \$100,000 or more? *G294. \$1,000 or more?

- 1. YES 5. NO 8. DK 1. YES 5. NO 8. DK

NEXT PAGE, G295

G295. INTERVIEWER CHECKPOINT

SEE G234, (P. 84) WIFE'S/"WIFE'S" MOTHER IS ALIVE ALL OTHERS TURN TO P. 94, G322

*G296. Is your (wife's/"WIFE'S") mother currently married to someone else?

- 1. YES 5. NO 8. DON'T KNOW ->TURN TO P. 94, G323

*G297. (Is her mother/Are her mother and stepfather) living with you now, in (her/their) home somewhere else, in another relative's home, in a nursing home, or what?

- 1. LIVING IN FU NOW ->NEXT PAGE, G311 2. LIVING IN HU NOW ->GO TO G300

3. IN OWN HOME SOMEWHERE ELSE 4. IN OTHER RELATIVE'S HOUSE 5. IN NURSING HOME 6. NOT LIVING TOGETHER 7. OTHER (SPECIFY):

*G298. About how far away from your house (does she/do they) live? Is it less than one mile, one to ten miles, eleven to 100 miles, or over 100 miles?

- 1. LESS THAN 1 MILE 2. 1-10 MILES 3. 11-100 MILES 4. OVER 100 MILES

*G299. What state or country (does she/do they) live in [MOST OF THE TIME]? ST-WF MO

*G300. Now about her mother's (and stepfather's) total yearly income from all sources (including such things as jobs, Social Security, and pensions), how much income did (her mother/they) receive in 1987?

\$ _____ INCOME-WF MO

NEXT PAGE, G304

9999998. DON'T KNOW 9999997. REFUSED

*G301. Would it amount to \$20,000 or more?

- 1. YES 5. NO 8. DK ->NEXT PAGE, G304

*G302. \$50,000 or more? *G303. \$5,000 or more?

- 1. YES 5. NO 8. DK 1. YES 5. NO 8. DK

NEXT PAGE, G304

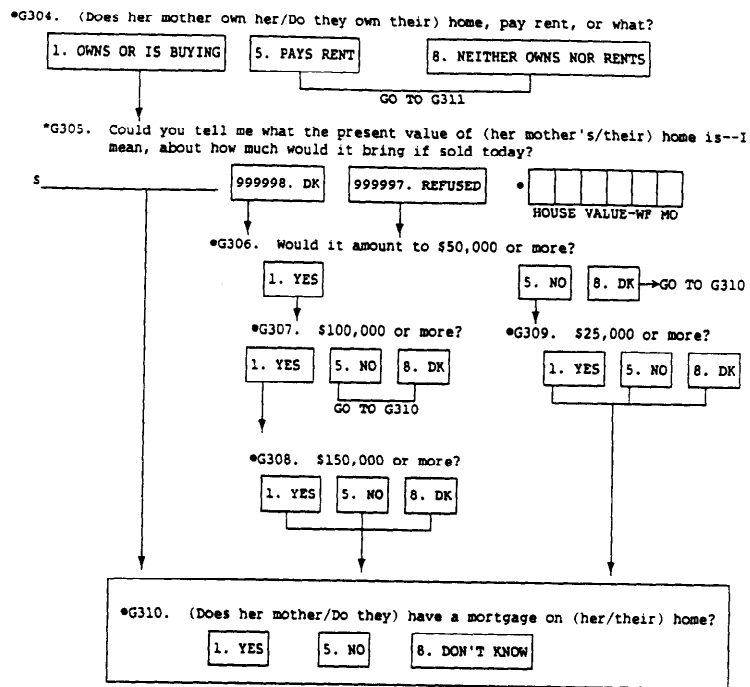

*G311. About help in the form of time, either in an emergency or with everyday activities such as errands, housework, small repairs to a car or baby-sitting--in 1987, did your family living there spend a lot of time helping your (wife's/"WIFE'S") mother (and stepfather)?

1. YES 5. NO → NEXT PAGE, G313

*G312. About how many hours in 1987 did your family living there spend helping (her/them)?

_____ HOURS IN 1987

*G313. How about time (her mother/they) spent helping you? In 1987, did her mother (and stepfather) spend a lot of time helping your family living there?

1. YES 5. NO → GO TO G315

*G314. About how many hours in 1987 did (she/they) spend helping your family living there?

_____ HOURS IN 1987

*G315. During 1987, did your family living there receive any loans, gifts, or support worth \$100 or more from your (wife's/"WIFE'S") mother (and stepfather)?

1. YES 5. NO → GO TO G317

*G316. About how much were those loans, gifts, or support worth altogether in 1987?

\$ _____ IN 1987

*G317. Suppose your (wife's/"WIFE'S") mother (and stepfather) were to sell all of (her/their) major possessions (including (her/their) home), turn all (her/their) investments and other assets into cash, and pay all (her/their) debts. Would (she/they) have something left over, break even, or be in debt?

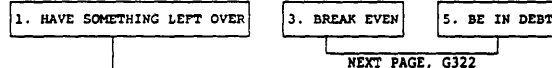

*G318. How much would (she/they) have left over?



*G319. Would it amount to \$25,000 or more?

1. YES 5. NO 8. DK → NEXT PAGE, G322

*G320. \$100,000 or more? *G321. \$1,000 or more?

1. YES 5. NO 8. DK 1. YES 5. NO 8. DK

NEXT PAGE, G322

44

*G322. During 1987, did (you/your family living there) receive any loans, gifts, or support worth \$100 or more from a friend or relative, besides parents, who was not living with you at the time?

1. YES 5. NO → NEXT PAGE, G333

*G323. From how many people did you receive help?

01 02 OTHER (SPECIFY):

G324. What is the person's name? G325. So that I can tell these people apart in the next few questions, can you give me their names?
G326. PRINT NAME(S) ON PEEL-OFF LABEL(S)

*G327. Now, talking about (NAME OF PERSON #1), what is (his/her) relationship to you?

HEAD'S EX-SPOUSE WIFE'S/"WIFE'S" EX-HUSBAND • [] [] [] [] • [] [] [] [] • [] [] [] []
 68ID PN REL

OTHER (SPECIFY): PLACE PEEL-OFF LABEL HERE

*G328. About how much were (his/her) loans, gifts, or support worth altogether in 1987? \$ _____ IN 1997

G329. INTERVIEWER CHECKPOINT

SEE G326 ABOVE
 MORE PERSONS ON PEEL-OFF LABELS → GO TO G330 NO MORE SUCH PERSONS → NEXT PAGE, G333

*G330. Now, talking about (NAME OF PERSON #2), what is (his/her) relationship to you?

HEAD'S EX-SPOUSE WIFE'S/"WIFE'S" EX-HUSBAND • [] [] [] [] • [] [] [] [] • [] [] [] []
 68ID PN REL

OTHER (SPECIFY): PLACE PEEL-OFF LABEL HERE

*G331. About how much were (his/her) loans, gifts, or support worth altogether in 1987? \$ _____ IN 1997

G332. INTERVIEWER CHECKPOINT

SEE G326 ABOVE
 MORE PERSONS ON PEEL-OFF LABELS NO MORE SUCH PERSONS
 REPEAT G330-G331 FOR EACH ADDITIONAL PERSON ON PEEL-OFF LABEL NEXT PAGE, G333

VARIABLES GENERATED FROM THIS SEQUENCE: V15918-V15942. MONEY HELP RECEIVED BY TYPE OF RELATIONSHIP (See tape code for details.)

*G333. About help in the form of time, either in an emergency or with everyday activities such as errands, housework, small repairs to a car, or baby-sitting--in 1987 did (you/your family living there) spend a lot of time helping a friend or relative, besides parents, who was not living with you then?

1. YES 5. NO → NEXT PAGE, G344

*G334. How many people did you help?

01 02 OTHER: _____

G335. What is the person's name? G336. So that I can tell these people apart in the next few questions, can you give me their names?
G337. PRINT NAME(S) ON PEEL-OFF LABEL(S)

*G338. Now, talking about (NAME OF PERSON #1), what is (his/her) relationship to you?

REL PLACE PEEL-OFF LABEL HERE

*G339. About how many hours in 1987 did (you/your family living there) spend helping (him/her)? _____ HOURS IN 1987

G340. INTERVIEWER CHECKPOINT

SEE G337 ABOVE
 MORE PERSONS ON PEEL-OFF LABELS NO MORE SUCH PERSONS
 GO TO G341 NEXT PAGE, G344

*G341. Now, talking about (NAME OF PERSON #2), what is (his/her) relationship to you?

REL PLACE PEEL-OFF LABEL HERE

*G342. About how many hours in 1987 did (you/your family living there) spend helping (him/her)? _____ HOURS IN 1987

G343. INTERVIEWER CHECKPOINT

SEE G337 ABOVE
 MORE PERSONS ON PEEL-OFF LABELS NO MORE SUCH PERSONS
 REPEAT G341-G342 FOR EACH ADDITIONAL PERSON ON PEEL-OFF LABEL NEXT PAGE, G344

VARIABLES GENERATED FROM THIS SEQUENCE: V15943-V15967, HOURS HELPED OTHERS BY TYPE OF RELATIONSHIP (See tape code for details.)

*G344. How about time other people spent helping you? In 1987, did a friend or relative, besides parents, not living with you at the time spend a lot of time helping (you/your family living there)?

1. YES 5. NO → NEXT PAGE, SECTION H

*G345. How many people was that?

01

02

OTHER: _____

G346. What is the person's name?	G347. So that I can tell these people apart in the next few questions, can you give me their names?
G348. PRINT NAME(S) ON PEEL-OFF LABEL(S)	

• •

68ID PN

*G349. Now, talking about (NAME OF PERSON #1), what is (his/her) relationship to you?

_____ •

REL

PLACE PEEL-OFF LABEL HERE

*G350. About how many hours in 1987 did (he/she) spend helping (you/your family living there)?

_____ HOURS IN 1987

G351. INTERVIEWER CHECKPOINT

SEE G348 ABOVE	• <input type="text"/> <input type="text"/> <input type="text"/> <input type="text"/> • <input type="text"/> <input type="text"/>
MORE PERSONS ON PEEL-OFF LABELS GO TO G352	NO MORE SUCH PERSONS NEXT PAGE, SECTION H

68ID PN

*G352. Now, talking about (NAME OF PERSON #2), what is (his/her) relationship to you?

_____ •

REL

PLACE PEEL-OFF LABEL HERE

*G353. About how many hours in 1987 did (he/she) spend helping (you/your family living there)?

_____ HOURS IN 1987

G354. INTERVIEWER CHECKPOINT

SEE G348 ABOVE	• <input type="text"/> <input type="text"/> <input type="text"/> <input type="text"/> • <input type="text"/> <input type="text"/>
MORE PERSONS ON PEEL-OFF LABELS REPEAT G352-G353 FOR EACH ADDITIONAL PERSON ON PEEL-OFF LABEL	NO MORE SUCH PERSONS NEXT PAGE, SECTION H

VARIABLES GENERATED FROM THIS SEQUENCE: V15968-V15992, HOURS RECEIVED HELP BY TYPE OF RELATIONSHIP
(See tape code for details.)

SECTION H: HEALTH

*H1. Now I have a few questions about your health, including any serious limitations you might have. Would you (HEAD) say your health in general is excellent, very good, good, fair, or poor?
V15993

1. EXCELLENT 2. VERY GOOD 3. GOOD 4. FAIR 5. POOR 8. DON'T KNOW

*H2. Do you (HEAD) have any physical or nervous condition that limits the type of work or the amount of work you can do?
V15994

1. YES 5. NO → GO TO H5

*H3. Does this condition keep you from doing some types of work?
V15995

1. YES 5. NO 8. DON'T KNOW 7. CAN DO NOTHING → GO TO H5

V15996 *H4. For work you can do, how much does it limit the amount of work you can do -- a lot, somewhat, or just a little?

1. A LOT 3. SOMEWHAT 5. JUST A LITTLE 7. NOT AT ALL

INTERVIEWER: SELECT PROPER TERM FOR H5 FROM LIST OF STATES BELOW:

MEDICAID: AL, AK, AZ, AR, CN, DE, DC, FL, GA, HI, ID, IL, IN, IA, KS, KE, LA, ME, MD, MN, MS, MO, NE, NV, NJ, NM, NY, NC, OH, OR, SC, TN, TX, VA, WA, WV

MEDI-CAL: CA

MEDICAL ASSISTANCE: MI, MT, NH, PA, RI, SD, UT, VT, WI, WY

WELFARE: CO, MA, ND

MEDICAL SERVICES: OK

*H5. Is anyone in your family living there covered by (Medicaid/Medi-Cal/Medical Assistance/Welfare/Medical Services)? [DO NOT INCLUDE MEDICARE]
V15997

1. YES 5. NO → NEXT PAGE, H7

*H6. Who is covered? [LIST ALL FAMILY MEMBERS COVERED]				
RELATION TO HEAD	SEX	AGE	PERSON NUMBER	SEQ #
_____	_____	_____	<input type="text"/> <input type="text"/>	<input type="text"/> <input type="text"/>
RELATION TO HEAD	SEX	AGE	PERSON NUMBER	SEQ #
_____	_____	_____	<input type="text"/> <input type="text"/>	<input type="text"/> <input type="text"/>
RELATION TO HEAD	SEX	AGE	PERSON NUMBER	SEQ #
_____	_____	_____	<input type="text"/> <input type="text"/>	<input type="text"/> <input type="text"/>

•H7. INTERVIEWER CHECKPOINT

V15998 SEE FU LISTING, (P. 2 OF COVER SHEET)

1. WIFE/"WIFE" IN FU NOW	5. ALL OTHERS → GO TO H12
--------------------------	---------------------------

•H8. Now I have a few questions about your (wife's/"WIFE's") health. Would you say her health in general is excellent, very good, good, fair, or poor?

1. EXCELLENT	2. VERY GOOD	3. GOOD	4. FAIR	5. POOR	8. DON'T KNOW
--------------	--------------	---------	---------	---------	---------------

•H9. Does your (wife/"WIFE") have any physical or nervous condition that limits the type of work or the amount of work she can do?

1. YES	5. NO → GO TO H12
--------	-------------------

V16001 •H10. Does this condition keep her from doing some types of work?

1. YES	5. NO	8. DON'T KNOW	7. CAN DO NOTHING → GO TO H12
--------	-------	---------------	-------------------------------

V16002 •H11. For work she can do, how much does it limit the amount of work she can do -- a lot, somewhat, or just little?

1. A LOT	3. SOMEWHAT	5. JUST A LITTLE	7. NOT AT ALL
----------	-------------	------------------	---------------

•H12. INTERVIEWER CHECKPOINT

V16003 SEE FU LISTING (PAGE 2 OF COVER SHEET)

1. SOMEONE IN FU OTHER THAN HEAD AND WIFE/"WIFE"	5. ALL OTHERS → NEXT PAGE, SECTION J
--	--------------------------------------

•H13. Now about the rest of your family living there--are any of them not in good health?

1. YES	5. NO → NEXT PAGE, SECTION J
--------	------------------------------

•H14. Who is that?

RELATION TO HEAD	SEX	AGE	PERSON NUMBER	SEQ #
_____	_____	_____	_____	□□
_____	_____	_____	_____	□□
_____	_____	_____	_____	□□
_____	_____	_____	_____	□□

SECTION J: MARRIAGE AND CHILDREN

•J1. INTERVIEWER CHECKPOINT

SEE FU LISTING, (P. 2 OF REINTERVIEW COVER SHEET) OR ITEM 3, (P. 1 OF SPLITOFF COVER SHEET)

MALE HEAD IN 1988 WAS HEAD LAST YEAR	3. FEMALE HEAD IN 1988 WAS HEAD/WIFE/"WIFE" LAST YEAR	4. ALL OTHERS
NEXT PAGE, J12		TURN TO P. 104, J46
WIFE IN 1988 WAS WIFE LAST YEAR	5. "WIFE" IN 1988	5. ALL OTHERS
NEXT PAGE, J12		NEXT PAGE, J12
1. WIFE IS UNDER AGE 45	2. WIFE IS AGE 45 OR OLDER	
TURN TO P. 114, J127		

•J2. We are updating the information we collected last year. Have you and your wife had any children since January 1987? [DO NOT COUNT STILLBIRTHS, STEPCHILDREN, OR ADOPTED CHILDREN]

1. YES	5. NO → GO TO J7
--------	------------------

•J3. How many is that?

01	02	OTHER: _____
----	----	--------------

J4. What is the child's name? J5. So that I can tell these children apart in the next few questions, can you give me their names?

J6. PRINT NAME(S) ON PEEL-OFF LABELS, ONE NAME TO EACH LABEL.

TURN TO GREEN OWN CHILDREN SUPPLEMENT

•J7. Have you or your wife legally adopted any children since January 1987?

1. YES	5. NO → TURN TO P. 114, J127
--------	------------------------------

•J8. How many is that?

01	02	OTHER: _____
----	----	--------------

J9. What is the child's name? J10. So that I can tell these children apart in the next few questions, can you give me their names?

J11. PRINT NAME(S) ON PEEL-OFF LABELS, ONE NAME TO EACH LABEL.

TURN TO GOLD ADOPTED CHILDREN SUPPLEMENT

J12. INTERVIEWER CHECKPOINT

SEE A3, (P. 1)--HEAD'S MARITAL STATUS

MARRIED	WIDOWED NEXT PAGE, J19	DIVORCED; MARRIAGE ANNULLED	SEPARATED	NEVER MARRIED TURN TO P. 103, J35
---------	------------------------------	-----------------------------	-----------	---

TURN TO P. 102, J26

*J13. In what month and year were you last married?

MONTH 1987 1988 OTHER YEAR:
TURN TO P. 103, J35

*J14. What (is/was) your (husband's/wife's) name?
[ACCEPT ANY NAME--DO NOT PROBE.
PRINT NAME ON PEEL-OFF LABEL.]

PLACE PEEL-OFF LABEL HERE

• [] [] [] [] • [] [] [] []
68 ID PN

*J15. Before that, were you widowed, divorced, separated, or had you never been married?

3. WIDOWED	4. DIVORCED; MARRIAGE ANNULLED	2. NEVER MARRIED	OTHER (SPECIFY):
------------	-----------------------------------	------------------	------------------

TURN TO P. 103, J35

*J16. In what month and year were you widowed?

MONTH YEAR

TURN TO P. 103, J35

*J17. In what month and year did your (divorce/annulment) become final?

MONTH YEAR

*J18. In what month and year did you stop living together?

MONTH YEAR

TURN TO P. 103, J35

[IF HEAD IS WIDOWED]

*J19. In what month and year were you widowed?

MONTH 1987 1988 OTHER YEAR:
TURN TO P. 103, J35

*J20. In what month and year were you last married?

MONTH 1987 1988 OTHER YEAR:
TURN TO P. 103, J35

*J21. What was your (husband's/wife's) name?
[ACCEPT ANY NAME--DO NOT PROBE.
PRINT NAME ON PEEL-OFF LABEL.]

PLACE PEEL-OFF LABEL HERE

• [] [] [] [] • [] [] [] []
68 ID PN

*J22. Before that, were you widowed, divorced, separated, or had you never been married?

3. WIDOWED	4. DIVORCED; MARRIAGE ANNULLED	2. NEVER MARRIED	OTHER (SPECIFY):
------------	-----------------------------------	------------------	------------------

TURN TO P. 103, J35

*J23. In what month and year were you widowed?

MONTH YEAR

TURN TO P. 103, J35

*J24. In what month and year did your (divorce/annulment) become final?

MONTH YEAR

*J25. In what month and year did you stop living together?

MONTH YEAR

TURN TO P. 103, J35

[IF HEAD IS DIVORCED OR SEPARATED]

J26. INTERVIEWER CHECKPOINT

SEE A3, (P. 1)--HEAD'S MARITAL STATUS

SEPARATED	DIVORCED; MARRIAGE ANNULLED
-----------	-----------------------------

*J27. In what month and year did your (divorce/annulment) become final?

MONTH	1987	1988	OTHER YEAR:
			NEXT PAGE, J35

*J28. In what month and year did you stop living together?

MONTH	1987	1988	OTHER YEAR:
			NEXT PAGE, J35

*J29. In what month and year were you last married?

MONTH	1987	1988	OTHER YEAR:
			NEXT PAGE, J35

*J30. What was your (husband's/wife's) name?
[ACCEPT ANY NAME--DO NOT PROBE. PRINT NAME ON PEEL-OFF LABEL.]

PLACE PEEL-OFF LABEL HERE

• 68 ID

• PM

*J31. Before that, were you widowed, divorced, separated, or had you never been married?

3. WIDOWED	4. DIVORCED; MARRIAGE ANNULLED	2. NEVER MARRIED	OTHER (SPECIFY):
	NEXT PAGE, J35		

*J32. In what month and year were you widowed?

MONTH	YEAR

*J33. In what month and year did your (divorce/annulment) become final?

MONTH	YEAR

*J34. In what month and year did you stop living together?

MONTH	YEAR

*J35. INTERVIEWER CHECKPOINT

SEE FU LISTING, (P. 2 OF COVER SHEET)

1. HEAD IS MALE	HEAD IS FEMALE AND:	
	2. AGE IS UNDER 45	3. AGE IS 45 OR OLDER
		TURN TO P. 114, J127

*J36. Have you yourself (fathered/given birth to) any children since January 1987? [DO NOT COUNT STILLBIRTHS, STEPCHILDREN, OR CHILDREN HEAD HAS ADOPTED.]

1. YES 5. NO → GO TO J41

*J37. How many is that?

01 02 OTHER: _____

J38. What is the child's name?	J39. So that I can tell these children apart in the next few questions, can you give me their names?
J40. PRINT NAME(S) ON PEEL-OFF LABELS, ONE NAME TO EACH LABEL.	
TURN TO GREEN OWN CHILDREN SUPPLEMENT	

*J41. Have you legally adopted any children since January 1987?

1. YES 5. NO → TURN TO P. 107, J69

*J42. How many is that?

01 02 OTHER: _____

J43. What is the child's name?	J44. So that I can tell these children apart in the next few questions, can you give me their names?
J45. PRINT NAME(S) ON PEEL-OFF LABELS, ONE NAME TO EACH LABEL.	
TURN TO GOLD ADOPTED CHILDREN SUPPLEMENT	

J46. INTERVIEWER CHECKPOINT

SEE A3, (P. 1)--HEAD'S MARITAL STATUS

A. HEAD HAS NEVER BEEN MARRIED → TURN TO P. 106, J60

B. ALL OTHERS

*J47. Now I'd like to ask about your (HEAD'S) family history. Altogether, how many times have you been married?

1. ONCE 2. TWICE OTHER: _____
NUMBER OF TIMES

NEXT PAGE, J54

HEAD'S FIRST MARRIAGE

*J48. In what month and year did you marry for the first time?

MONTH YEAR

*J49. What was your first (husband's/wife's) name?
 [ACCEPT ANY NAME--DO NOT PROBE. PRINT NAME ON PEEL-OFF LABEL.]

• •
68 ID PH

PLACE PEEL-OFF LABEL HERE

*J50. Did that marriage end in widowhood, divorce, or what?

3. WIDOWHOOD 4. DIVORCE, ANNULMENT OTHER (SPECIFY): _____

*J51. In what month and year were you widowed?

MONTH YEAR

*J52. In what month and year did your (divorce/annulment) become final?

MONTH YEAR

*J53. In what month and year did you stop living together?

MONTH YEAR

*J54. In what month and year were you (last) married?

MONTH YEAR

PLACE PEEL-OFF LABEL HERE

*J55. [IF NOT CLEAR] What (is/was) your (husband's/wife's) name?
 [ACCEPT ANY NAME--DO NOT PROBE. PRINT NAME ON PEEL-OFF LABEL.]

• •
68 ID PH

J56. INTERVIEWER CHECKPOINT

SEE A3, (P. 1)--HEAD'S MARITAL STATUS

MARRIED → NEXT PAGE, J60

WIDOWED → *J57. In what month and year were you widowed?

MONTH YEAR

NEXT PAGE, J60

DIVORCED; MARRIAGE ANNULLED → *J58. In what month and year did your (divorce/annulment) become final?

MONTH YEAR

SEPARATED → *J59. In what month and year did you stop living together?

MONTH YEAR

NEXT PAGE, J60

*J60. Now, we would like to ask about births of children. How many children have you yourself (HEAD) ever (fathered/given birth to)?
 [DO NOT COUNT STILLBIRTHS, STEPCHILDREN, OR CHILDREN HEAD HAS ADOPTED]

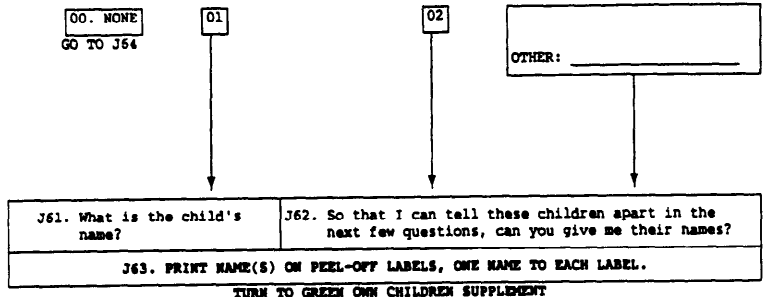

*J64. Have you (HEAD) ever legally adopted any children?

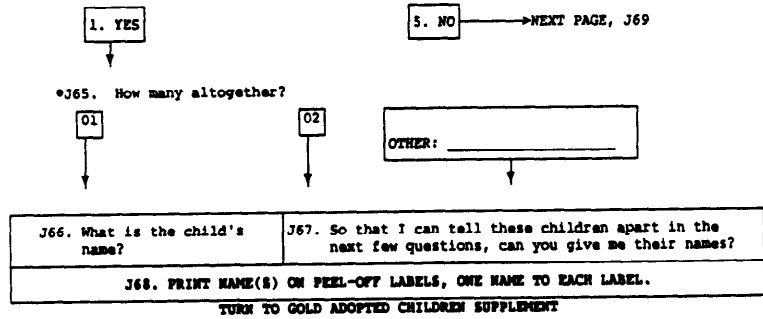

*J69. INTERVIEWER CHECKPOINT

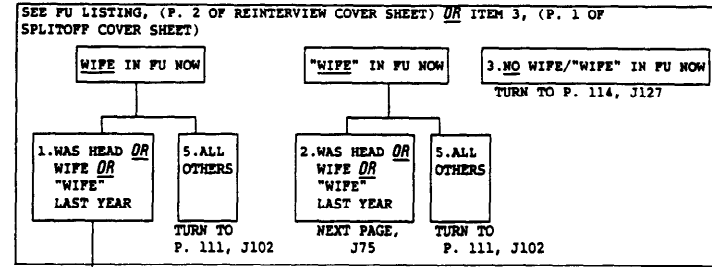

*J70. Please tell me again, in what month and year were you and your wife last married?

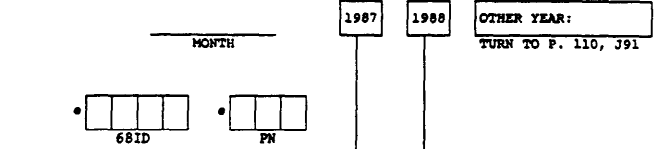

*J71. Before that, was she widowed, divorced, separated, or had she never been married?

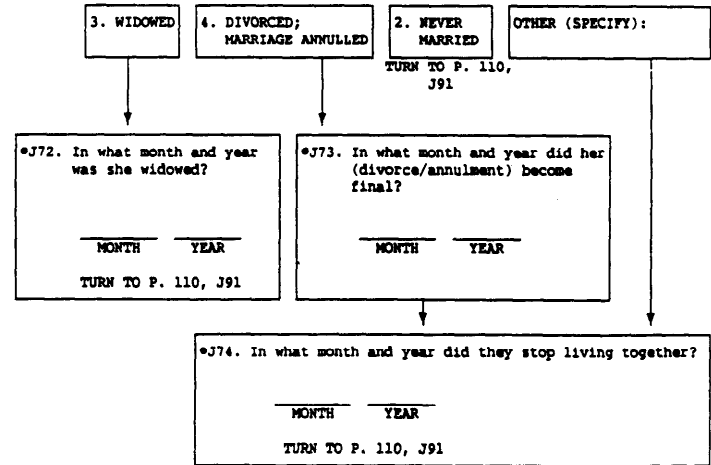

*J75. Is your ("WIFE") married, widowed, divorced, separated, or has she never been married?



*J76. In what month and year did her (divorce/annulment) become final?

MONTH 1987 1988 OTHER YEAR: _____

TURN TO P. 110, J91

*J77. In what month and year did she and her (former) husband stop living together?

MONTH 1987 1988 OTHER YEAR: _____

TURN TO P. 110, J91

*J78. In what month and year were they last married?

MONTH 1987 1988 OTHER YEAR: _____

TURN TO P. 110, J91

*J79. What was her husband's name? [ACCEPT ANY NAME--DO NOT PROBE. PRINT NAME ON PEEL-OFF LABEL.]

• [] [] [] [] • [] [] [] []

68 ID FN

PLACE PEEL-OFF LABEL HERE

*J80. Before that, was she widowed, divorced, separated, or had she never been married?

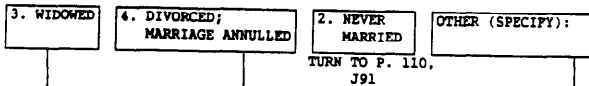

*J81. In what month and year was she widowed?

MONTH YEAR

TURN TO P. 110, J91

*J82. In what month and year did her (divorce/annulment) become final?

MONTH YEAR

*J83. In what month and year did they stop living together?

MONTH YEAR

TURN TO P. 110, J91

[IF "WIFE" IS WIDOWED]

*J84. In what month and year was she widowed?

MONTH 1987 1988 OTHER YEAR: _____

NEXT PAGE, J91

*J85. In what month and year were she and her husband last married?

MONTH 1987 1988 OTHER YEAR: _____

NEXT PAGE, J91

*J86. What was her husband's name? [ACCEPT ANY NAME--DO NOT PROBE. PRINT NAME ON PEEL-OFF LABEL.]

• [] [] [] [] • [] [] [] []

68 ID FN

PLACE PEEL-OFF LABEL HERE

*J87. Before that, was she widowed, divorced, separated, or had she never been married?

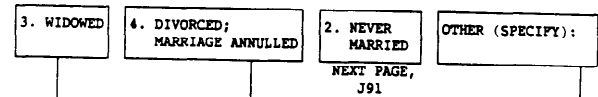

*J88. In what month and year was she widowed?

MONTH YEAR

*J89. In what month and year did her (divorce/annulment) become final?

MONTH YEAR

*J90. In what month and year did they stop living together?

MONTH YEAR

*J91. INTERVIEWER CHECKPOINT

SEE FU LISTING, (P. 2 OF COVER SHEET)

1. WIFE/"WIFE"
IS UNDER AGE 452. WIFE/"WIFE" IS
AGE 45 OR OLDER

TURN TO P. 114, J127

*J92. Has your (wife/"WIFE") given birth to any children since January 1987?
[DO NOT COUNT STILLBIRTHS, STEPCHILDREN, OR CHILDREN WIFE/"WIFE" HAS ADOPTED]

1. YES

5. NO → GO TO J97

*J93. How many is that?

01

02

OTHER: _____

J94. What is the child's
name?J95. So that I can tell these children apart in the
next few questions, can you give me their names?

J96. PRINT NAME(S) ON PEEL-OFF LABELS, ONE NAME TO EACH LABEL.

TURN TO GREEN OWN CHILDREN SUPPLEMENT

*J97. Has your (wife/"WIFE") legally adopted any children since January 1987?

1. YES

5. NO → TURN TO P. 114, J127

*J98. How many is that?

01

02

OTHER: _____

J99. What is the child's
name?J100. So that I can tell these children apart in the
next few questions, can you give me their names?

J101. PRINT NAME(S) ON PEEL-OFF LABELS, ONE NAME TO EACH LABEL.

TURN TO GOLD ADOPTED CHILDREN SUPPLEMENT

J102. Now I'd like to ask about your (wife's/"WIFE'S") family history.

*J103. INTERVIEWER CHECKPOINT

SEE FU LISTING, (P. 2 OF COVER SHEET)

1. HEAD HAS WIFE IN FU NOW
GO TO J1052. HEAD HAS "WIFE" IN FU NOW*J104. Is your ("WIFE") married, widowed, divorced, separated, or has she never
been married?

1. MARRIED

3. WIDOWED

4. DIVORCED,
ANNULMENT

5. SEPARATED

2. NEVER MARRIED

TURN TO P. 113, J118

*J105. Altogether, how many times has she been married?

1. ONCE

2. TWICE

OTHER: _____

NEXT PAGE, J112

NUMBER OF TIMES

WIFE'S/"WIFE'S"
FIRST MARRIAGE*J106. In what month and year did she marry for the first time?

____ MONTH ____ YEAR

PLACE PEEL-OFF
LABEL HERE*J107. What was her first husband's name?
[ACCEPT ANY NAME--DO NOT PROBE.
PRINT NAME ON PEEL-OFF LABEL.]• [] [] [] []
68 ID• [] [] []
PN

*J108. Did that marriage end in widowhood, divorce, or what?

3. WIDOWHOOD

4. DIVORCE, ANNULMENT

OTHER (SPECIFY):
_____*J109. In what month and year
was she widowed?

____ MONTH ____ YEAR

*J110. In what month and year did her
(divorce/annulment) become final?

____ MONTH ____ YEAR

*J111. In what month and year did they stop living
together?

____ MONTH ____ YEAR

*J112. (Please tell me again), in what month and year (were you and she/was she) (last) married?

____ MONTH ____ YEAR

PLACE PEEL-OFF LABEL HERE

*J113. [IF NOT CLEAR] What (is/was) her husband's name? [ACCEPT ANY NAME--DO NOT PROBE. PRINT NAME ON PEEL-OFF LABEL.]

• [] [] [] [] 68 ID • [] [] [] [] PN

J114. INTERVIEWER CHECKPOINT

SEE J103 OR J104 (P. 111)--WIFE'S/"WIFE'S" MARITAL STATUS

WIFE IN FU NOW → NEXT PAGE, J118

"WIFE" IS WIDOWED → *J115. In what month and year was she widowed?

____ MONTH ____ YEAR

NEXT PAGE, J118

"WIFE" IS DIVORCED; MARRIAGE ANNULLED → *J116. In what month and year did her (divorce/annulment) become final?

____ MONTH ____ YEAR

"WIFE" IS SEPARATED OR MARRIED → *J117. In what month and year did they stop living together?

____ MONTH ____ YEAR

NEXT PAGE, J118

*J118. Now, we would like to ask about births of children. How many children has your (wife/"WIFE") ever given birth to? [DO NOT COUNT STILLBIRTHS, STEPCHILDREN OR CHILDREN WIFE/"WIFE" HAS ADOPTED]

00. NONE GO TO J122 01 02 OTHER: _____

J119. What is the child's name? J120. So that I can tell these children apart in the next few questions, can you give me their names?

J121. PRINT NAME(S) ON PEEL-OFF LABELS, ONE NAME TO EACH LABEL.

TURN TO GREEN OWN CHILDREN SUPPLEMENT

*J122. Has your (wife/"WIFE") ever legally adopted any children?

1. YES 5. NO → NEXT PAGE, J127

*J123. How many altogether?

01 02 OTHER: _____

J124. What is the child's name? J125. So that I can tell these children apart in the next few questions, can you give me their names?

J126. PRINT NAME(S) ON PEEL-OFF LABELS, ONE NAME TO EACH LABEL.

TURN TO GOLD ADOPTED CHILDREN SUPPLEMENT

*J127. INTERVIEWER CHECKPOINT

SEE FU LISTING, (P. 2 OF COVER SHEET)	
<input type="checkbox"/> 1. SOMEONE IN FU NOW IS AGE 12 THROUGH 44 (OTHER THAN HEAD AND WIFE/"WIFE")	<input type="checkbox"/> 5. ALL OTHERS
NEXT PAGE, SECTION K	

[IF NON-FU MEMBERS IN HU]: In the following questions, we will be talking about persons living there, excluding (READ NAMES OF NON-FU MEMBERS FROM COVER SHEET).

*J128. Other than you (or your wife/"WIFE"), has anyone under age 45 in your family living there ever had any children?

<input type="checkbox"/> 1. YES	<input type="checkbox"/> 5. NO → GO TO J130
---------------------------------	---

J129. Who is that? [LIST IN GRID AT J132]

*J130. Other than you (or your wife/"WIFE"), has (INDIVIDUAL MENTIONED or) anyone (else) in your family living there under age 45 ever been married at some time?

<input type="checkbox"/> 1. YES	<input type="checkbox"/> 5. NO → GO TO J133
---------------------------------	---

J131. Who is that? [LIST ANY ADDITIONAL INDIVIDUALS IN GRID AT J132]

J132. OTHER FU MEMBERS UNDER AGE 45 WHO HAVE HAD CHILDREN OR BEEN MARRIED

OTHER FU MEMBER	RELATIONSHIP TO HEAD	CURRENT AGE	PERSON NUMBER
A			
B			
C			
D			

REMEMBER TO ASK BOTH J128 AND J130 BEFORE MARKING J133 CHECKPOINT!!!

J133. INTERVIEWER CHECKPOINT

SEE J132 GRID ABOVE	
<input type="checkbox"/> A. SOMEONE IS LISTED IN J132 GRID	<input type="checkbox"/> B. ALL OTHERS
NEXT PAGE, SECTION K	
COMPLETE A BOOKLET FOR MARRIAGE HISTORY AND CHILDREN OF OTHER FU MEMBERS FOR EACH PERSON LISTED IN GRID	

*K1. INTERVIEWER CHECKPOINT
V16005

SEE FU LISTING, (P.2 OF COVER SHEET)			SPLITOFF (PINK) COVER SHEET AND:	
REINTERVIEW (AQUA) COVER SHEET AND:			SPLITOFF (PINK) COVER SHEET AND:	
<input type="checkbox"/> 1. NEW WIFE/"WIFE" IN FU FOR 1988	<input type="checkbox"/> 5. SAME WIFE/"WIFE" IN FU	<input type="checkbox"/> 5. NO WIFE/"WIFE" IN FU	<input type="checkbox"/> 1. WIFE/"WIFE" IN FU	<input type="checkbox"/> 5. NO WIFE/"WIFE" IN FU
TURN TO P. 120, SECTION L			TURN TO P. 120, SECTION L	

*K2. Now I have some questions about your (wife's/"WIFE'S") family and past experiences. How much education did her father have? [ACCEPT FATHER SUBSTITUTE]

V16006

*K3. [IF FEWER THAN 6 GRADES] Could he read and write?

*K4. How much education did your (wife's/"WIFE'S") mother have? [ACCEPT MOTHER SUBSTITUTE]

V16007

*K5. [IF FEWER THAN 6 GRADES] Could she read and write?

*K6. Now I have some questions about brothers and sisters. Did your (wife/"WIFE") have any brothers?
 V16008 [INCLUDE NATURAL SIBLINGS ONLY]

1.YES 5.NO → GO TO K12

*K7. How many brothers was that?
 V16009

01 NUMBER _____

<p>*K8. Is he still living? V16010</p> <p>1.YES 5.NO</p> <p>*K9. Was he older than she is? V16011</p> <p>1.YES 5.NO</p>	<p>*K10. How many of them are still living? V16012</p> <p>ALL 00. NONE</p> <p>NUMBER _____</p> <p>*K11. Were any of her brothers older than she is? V16013</p> <p>1.YES 5.NO</p>
---	--

*K12. Did she have any sisters?
 V16014 [INCLUDE NATURAL SIBLINGS ONLY]

1.YES 5.NO → NEXT PAGE, K18

*K13. How many sisters was that?
 V16015

01 NUMBER _____

<p>*K14. Is her sister still living? V16016</p> <p>1.YES 5.NO</p> <p>*K15. Was she older than your (wife/"WIFE")? V16017</p> <p>1.YES 5.NO</p>	<p>*K16. How many of them are still living? V16018</p> <p>ALL 00. NONE</p> <p>NUMBER _____</p> <p>*K17. Were any of her sisters older than she is? V16019</p> <p>1.YES 5.NO</p>
--	---

*K18. In order to get an idea of the different races and ethnic groups that participate in the study, I would like to ask you about your (wife's/"WIFE'S") ethnic origin. Is she of Spanish or Hispanic descent, that is, Mexican, Mexican American, Chicano, Puerto Rican, Cuban, or other Spanish? [IF NECESSARY: Which one?]

1.MEXICAN 2.MEXICAN AMERICAN 3.CHICANO 4.PUERTO RICAN 5. CUBAN 0. IS NOT SPANISH/HISPANIC

OTHER SPANISH (SPECIFY): _____

*K19. And, is she white, black, American Indian, Aleut, Eskimo, Asian, Pacific Islander, or another race?
 [CHECK ALL THAT APPLY]

FIRST MENTION=V16021, SECOND MENTION=V16022

1.WHITE 2.BLACK 3.AMERICAN INDIAN, ALEUT, ESKIMO 4. ASIAN, PACIFIC ISLANDER OTHER (SPECIFY): _____

*K20. Has she ever been in the United States military service?
 V16023

1.YES 5.NO

*K21. Now I would like to talk about the education your (wife/"WIFE") has received. Did she graduate from high school, get a GED, or neither?
V16024

1. GRADUATED FROM HIGH SCHOOL 2. GOT A GED 3. NEITHER

*K22. In what year did she graduate?
V16025
YEAR
GO TO K28

*K23. How many grades of school did she finish prior to getting her GED?
V16026 00. NONE
GRADES FINISHED GO TO K25

*K24. In what year did she last attend (GRADE IN K23)?
V16027
YEAR

*K25. In what year did she receive her GED?
V16028
YEAR

*K26. How many grades of school did she finish?
V16029 00. NONE
GRADES FINISHED GO TO K28

*K27. In what year did she last attend (GRADE IN K26)?
V16030
YEAR

*K28. Did she attend college? 1. YES 5. NO → NEXT PAGE, K36
V16031

*K29. In what year did she last attend college? YEAR
V16032

*K30. What is the highest year of college she has completed?
V16033

0. LESS THAN ONE YEAR → NEXT PAGE, K36 1 2 3 4 5+

*K31. Did she receive a college degree? 1. YES 5. NO → NEXT PAGE, K36
V16034

*K32. What is the highest college degree she has received? V16035

K33. What was the name of the college? _____

K34. Where was it located? CITY STATE

*K35. In what year did she receive that degree? V16036
YEAR

*K36. Did your (wife/"WIFE") receive any other degree or a certificate through a vocational school, a training school, or an apprenticeship program?
V16037

1. YES 5. NO → GO TO K42

	FIRST	SECOND	THIRD
*K37. What type of degree or certificate was that?	V16039	V16043	V16047
*K38. In what field was that?	V16040	V16044	V16048
*K39. From what type of institution or organization was that?	V16041	V16045	V16049
*K40. In what year did she receive that degree or certificate?	V16042 YEAR	V16046 YEAR	V16050 YEAR
K41. Did she receive any other training degree or certificate?	YES NO ASK K37- K41 AGAIN GO TO K42	YES NO ASK K37- K41 AGAIN GO TO K42	YES NO ASK K37- K41 AGAIN GO TO K42

TOTAL NUMBER OF DEGREES OR CERTIFICATES=V16038

*K42. Is your (wife's/"WIFE's") religious preference Protestant, Catholic, or Jewish, or what?
V16051

PROTESTANT 01. CATHOLIC 02. JEWISH OTHER (SPECIFY): _____

GO TO K44

K43. What denomination is that? _____

*K44. How many years altogether has your (wife/"WIFE") worked for money since she was 18?
V16052 → YEARS 00. NONE → NEXT PAGE, SECTION L

*K45. How many of these years did she work full-time for most or all of the year?
V16053 YEARS OR ALL

SECTION L: BACKGROUND AND EDUCATION OF NEW HEAD

*L1. INTERVIEWER CHECKPOINT

V16054

SEE PU LISTING, (P. 2 OF COVER SHEET)

REINTERVIEW (AQUA) COVER SHEET AND:

1. NEW HEAD IN FU IN 1988

5. SAME HEAD IN FU

1. SPLITOFF (PINK) COVER SHEET

TIME END: _____

TURN TO P. 3 OF REINTERVIEW COVER SHEET

*L2. Now I have some questions about your (HEAD'S) family and past experiences. Where did your father grow up? [MOST OF THE YEARS FROM AGES 6 TO 16--ACCEPT FATHER SUBSTITUTE]

NAME OF STATE; COUNTRY, IF FOREIGN _____

COUNTY _____

OR

TOWN _____

ST, CO- FA

V16055 V16056

*L3. Where did your mother grow up? [ACCEPT MOTHER SUBSTITUTE]

NAME OF STATE; COUNTRY, IF FOREIGN _____

COUNTY _____

OR

TOWN _____

ST, CO- MO

V16057 V16058

*L4. What was your father's usual occupation when you were growing up? [ACCEPT FATHER SUBSTITUTE]

_____ V16059

OCC

*L5. Thinking of your (HEAD'S) first full-time regular job, what did you do?

_____ V16060

0. NEVER WORKED

NEXT PAGE, L7 OCC

*L6. Have you had a number of different kinds of jobs, or have you mostly worked in the same occupation you started in, or what?

V16061

*L7. Did you (HEAD) grow up on a farm, in a small town, in a large city, or what?

1. FARM

2. SMALL TOWN

3. LARGE CITY

OTHER (SPECIFY): _____

*L8. In what state and county was that? [EXAMPLE: ILLINOIS, COOK COUNTY]

STATE _____ AND COUNTY _____

DON'T KNOW COUNTY

ST, CO- H

V16063 V16064

L9. What was the name of the nearest town?

*L10. What other states or countries have you lived in, including time spent abroad while in the armed forces? ["LIVED IN" MEANS STAYED AT LEAST 3 MONTHS.]

TOTAL NUMBER OF REGIONS=V16065, TOTAL NUMBER OF STATES AND/OR COUNTRIES=V16066

*L11. Have you (HEAD) ever moved out of a community where you were living in order to take a job somewhere else?

1. YES → GO TO L13

5. NO

*L12. Have you (HEAD) ever turned down a job because you did not want to move?

1. YES

5. NO

*L13. Were your parents poor when you were growing up, pretty well off, or what?

V16069

*L14. How much education did your (HEAD'S) father have? [ACCEPT FATHER SUBSTITUTE]

V16070

*L15. [IF FEWER THAN 6 GRADES] Could he read and write?

*L16. How much education did your (HEAD'S) mother have? [ACCEPT MOTHER SUBSTITUTE]

V16071

*L17. [IF FEWER THAN 6 GRADES] Could she read and write?

*L18. Now I have some questions about brothers and sisters. Did you (HEAD) have any brothers?
V16072 [INCLUDE NATURAL SIBLINGS ONLY]

1.YES 5.NO → GO TO L24

*L19. How many brothers was that?
V16073

01 NUMBER _____

<p>*L20. Is he still living? V16074</p> <p>1.YES 5.NO</p> <p>*L21. Was he older than you? V16075</p> <p>1.YES 5.NO</p>	<p>*L22. How many of them are still living?</p> <p>V16076 ALL 00. NONE NUMBER</p> <p>*L23. Were any of your brothers older than you? V16077</p> <p>1.YES 5.NO</p>
--	--

*L24. Did you have any sisters?
V16078 [INCLUDE NATURAL SIBLINGS ONLY]

1.YES 5.NO → NEXT PAGE, L30

*L25. How many sisters was that?
V16079

01 NUMBER _____

<p>*L26. Is she still living? V16080</p> <p>1.YES 5.NO</p> <p>*L27. Was she older than you? V16081</p> <p>1.YES 5.NO</p>	<p>*L28. How many of them are still living?</p> <p>V16082 ALL 00. NONE NUMBER</p> <p>*L29. Were any of your sisters older than you? V16083</p> <p>1.YES 5.NO</p>
--	---

*L30. Were you living with both your natural parents most of the time until you were age 16?
V16084

1.YES 5.NO

*L31. In order to get an idea of the different races and ethnic groups that participate in the study, I would like to ask you about your ethnic origin. Are you of Spanish or Hispanic descent, that is, Mexican, Mexican American, Chicano, Puerto Rican, Cuban, or other Spanish? [IF NECESSARY: Which one?]

1.MEXICAN 2.MEXICAN AMERICAN 3.CHICANO 4.PUERTO RICAN 5. CUBAN 0. IS NOT SPANISH/HISPANIC

OTHER SPANISH (SPECIFY): _____

*L32. And, are you white, black, American Indian, Aleut, Eskimo, Asian, Pacific Islander, or another race?
[CHECK ALL THAT APPLY]

FIRST MENTION=V16086, SECTION MENTION=V16087

1.WHITE	2.BLACK	3.AMERICAN INDIAN, ALEUT, ESKIMO	4. ASIAN, PACIFIC ISLANDER	OTHER (SPECIFY): _____ _____ _____
---------	---------	----------------------------------	----------------------------	---

*L33. Have you ever been in the United States military service?
V16088

1.YES 5.NO

*L34. Now I would like to talk about the education you (HEAD) have received. Did you graduate from high school, get a GED, or neither?
V16089

1. GRADUATED FROM HIGH SCHOOL 2. GOT A GED 3. NEITHER

*L35. In what month and year did you graduate?

V16090 V16091
MONTH YEAR

GO TO L41

<p>*L36. How many grades of school did you (HEAD) finish prior to getting your GED?</p> <p>V16092 <input type="checkbox"/> 00. NONE GRADES FINISHED GO TO L38</p> <p>*L37. In what month and year did you last attend (GRADE IN L36)?</p> <p>V16093 V16094 MONTH YEAR</p> <p>*L38. In what month and year did you receive your GED?</p> <p>V16095 V16096 MONTH YEAR</p>	<p>*L39. How many grades of school did you (HEAD) finish?</p> <p>V16097 <input type="checkbox"/> 00. NONE GRADES FINISHED GO TO L41</p> <p>*L40. In what month and year did you last attend (GRADE IN L39)?</p> <p>V16098 V16099 MONTH YEAR</p>
---	---

*L41. Did you attend college? 1. YES 5. NO → NEXT PAGE, L49
V16100

*L42. In what month and year did you last attend college? V16101 V16102
MONTH YEAR

*L43. What is the highest year of college you have completed?
V16103

0. LESS THAN ONE YEAR → NEXT PAGE, L49 1 2 3 4 5*

*L44. Did you receive a college degree? 1. YES 5. NO → NEXT PAGE, L49
V16104

*L45. What is the highest college degree you have received? V16105

L46. What was the name of the college? _____

L47. Where was it located? _____ _____
CITY STATE

*L48. In what month and year did you receive that degree? V16106 V16107
MONTH YEAR

*L49. Did you (HEAD) receive any other degree or a certificate through a vocational school, a training school, or an apprenticeship program?
V16108

1. YES 5. NO → GO TO L55

	FIRST	SECOND	THIRD
*L50. What type of degree or certificate was that?	V16110	V16115	V16120
*L51. In what field was that?	V16111	V16116	V16121
*L52. From what type of institution or organization was that?	V16112	V16117	V16122
*L53. In what month and year did you receive that degree or certificate?	V16113 V16114 MONTH YEAR	V16118 V16119 MONTH YEAR	V16123 V16124 MONTH YEAR
L54. Did you receive any other training degree or certificate?	<input type="checkbox"/> YES <input type="checkbox"/> NO ASK L50- GO TO L54 AGAIN L55	<input type="checkbox"/> YES <input type="checkbox"/> NO ASK L50- GO TO L54 AGAIN L55	<input type="checkbox"/> YES <input type="checkbox"/> NO ASK L50- GO TO L54 AGAIN L55

TOTAL NUMBER OF DEGREES OR CERTIFICATES=V16109
*L55. Is your religious preference Protestant, Catholic, or Jewish, or what?
V16125

PROTESTANT 01. CATHOLIC 02. JEWISH OTHER (SPECIFY): _____

GO TO L57

L56. What denomination is that? _____

*L57. How many years altogether have you (HEAD) worked for money since you were 18?

V16126 YEARS 00. NONE → TIME END: _____
TURN TO P. 3 OF REINTERVIEW COVER SHEET
OR P. 4 OF SPLITOFF COVER SHEET

*L58. How many of these years did you work full-time for most or all of the year?
V16127 YEARS OR ALL

TIME END: _____
TURN TO P. 3 OF REINTERVIEW COVER SHEET
OR P. 4 OF SPLITOFF COVER SHEET